



Instruction Manual Power Analysis Software

TABLE OF CONTENTS

Power Analysis Software Overview	1
Required Equipment	1
Using Non-ProBus Probes	2
Method of Operation.....	3
Power Analysis Software Dialogs.....	4
Power Analysis Dialog.....	4
Input Settings Dialog.....	4
Zone Identification Dialog.....	5
Other Dialogs	5
Deskew Voltage and Current Channels	6
Power Device Analysis	8
Device Analysis Preliminary Setup	8
Set Up Device Analysis Input Channels.....	10
Identify Switching Zone.....	11
Device Losses Test.....	12
Device Safe Operating Area Test	14
Device B-H Curve Test.....	15
Device Dynamic On-resistance Test.....	16
Device dv/dt Test	17
Control Loop Analysis.....	18
Control Loop Analysis Preliminary Setup	18
Set Up Control Loop Analysis Source Channel.....	20
Closed Loop Test	21
Line Power Analysis	22
Line Power Analysis Preliminary Setup.....	22
Set Up Line Power Analysis Source Channels	23
Line Power Test.....	24
Line Harmonics Test.....	25

Power Analysis Software Overview

The Power Analyzer Software (PAS) option helps measure and analyze the operating characteristics of power-conversion devices and circuits for off-line, DC-DC and DC-AC power circuit designs. It provides automatic detection and measurement of switching device losses, control loop response to load/line changes, and line power quality and harmonics for compliance testing.

Areas of power loss are clearly delineated by a color-coded waveform overlay, and tools are provided to reduce the sources of measurement errors. Thanks to a streamlined user interface, you are guided through various stages of analysis. There are operating modes for power-switching device measurements, control-loop modulation analysis, and line-power harmonics.

All Teledyne LeCroy voltage and current probes are integrated with the software, and measurements are automatic and precise. Documentation and Flashback to prior power-circuit analyses can be accomplished through LabNotebook.

PAS consists of these major analysis areas:

- **Device Analysis** covers the measurement of switching device performance such as device instantaneous power, switching losses, safe operating area (SOA), saturation voltage, dynamic on-resistance, dv/dt or di/dt , and saturation hysteresis curves of magnetic devices. With PAS, these device measurements can be made either on a test stand or in circuit while the devices are operating in a power conversion system.
- **Control Loop Analysis** covers the acquisition and analysis of information contained in a power conversion circuit's modulated control signal. It analyzes modulation changes in pulse width (PWM), duty cycle, frequency, or period as the feedback loop responds to changes in line and/or load, as well as during start-up and shut-down.
- **Line Power Analysis** covers the measurement of line voltage and current applied to an off-line power conversion device. Real power, apparent power, power factor, crest factor, and line harmonics are measured. Analysis of line harmonic content is included to assist the design and evaluation engineer in designing for pre-compliance to EN 61000-3-2 requirements.

Required Equipment

You will need this equipment to utilize the Power Analysis Software.

Oscilloscope. Power Analyzer Software option operates on any Teledyne LeCroy Windows-based oscilloscope. For analysis of phenomenon requiring the acquisition of many cycles, an oscilloscope with a minimum memory of 1 Mpt per channel is recommended. Steady-state analysis can be accomplished with shorter record lengths. Two acquisition channels are adequate for most measurements, but a four-channel oscilloscope is recommended if you would like to analyze multiple devices or use complex triggering. To see the small signal details hidden in large signals, such as a saturation voltage, or ripple transient analysis, a 12-bit oscilloscope is recommended.

Voltage Probes. A wide range of voltage probes are available and are integrated within this software. Proper selection of the following probes should match circuit details, including: single-ended passive, single-ended high voltage, differential high-voltage, active single and differential high-frequency, and 50 Ohm transmission line probe. Differential voltage probes will support your measurement environment including isolating your circuits from line power, measuring currents with current sensing resistors, and viewing switching transients in power supply ripple measurements.

Differential Amplifier. Measuring high-side gate drive signals in an off-line application and capturing a device saturation voltage to measure conduction loss or $R_{ds(on)}$ are challenging to do. These require a voltage probing solution that has high CMRR, fast overdrive recovery, voltage clamping (so the oscilloscope is not overdriven), compensation flatness, gain/ amplification to see small signal details, and precise offset generation to see the switching device's turn-off performance. The Teledyne LeCroy **DA1855A** and its associated **DXC Series Passive Differential Probes** are required.

Current Probes. The measurements described in Power Device Analysis require precision wide-bandwidth current probes with DC measurement capability. We recommend Teledyne LeCroy:

- **AP015** or **CP030** DC-to-50 MHz, 30-ampere current probe
- **CP031** DC-to-100 MHz, 30-ampere current probe
- **CP150** and **CP500** high-current probes

Other, higher current probes are also available from Teledyne LeCroy.

Deskew Signal Source. To assist with eliminating propagation delay differences among voltage and current probes used for device testing, the **DCS015** de skew calibrated source is recommended. This source has time-coincident voltage and current signals used to adjust deskew values within the oscilloscope channel controls and Power Analyzer software.

Using Non-ProBus Probes

Teledyne LeCroy ProBus probes automatically use correct units and scaling for power measurements when used with the Power Analyzer software. When other probes are used, the Power Analyzer Software provides methods for entering the correct units and scaling.

When a channel is selected as the current input within the software, its units are automatically changed to Amperes. When a differential probe is used to measure the voltage across a shunt resistor, the Power Analyzer software will support the proper amps/div scaling when the resistor value is entered.

Method of Operation

The general process for conducting Power Analysis follows:

1. Set up DUT test circuit, consider isolation requirements, attach probes, and setup oscilloscope trigger

This includes all physical circuit setup and oscilloscope setup for timebase and acquisition triggers. We show recommended connections, probing points, and trigger events for each type of analysis in the preliminary setup topics.

2. Set up voltage and current source channels

Make all Vertical settings on the channels to be used for a test and perform all necessary preliminary adjustments to ensure measurement accuracy.

Because signals associated with power devices are relatively fast, it is important to determine whether the propagation time for the current and voltage signal paths are the same. Signal delay characteristics of the voltage and current probes, as well as the distance the signals must travel from the probe tips to the input of the oscilloscope, can cause time-coincident points on the voltage and current signals to be sampled by the oscilloscope at different times. Even a small time difference can cause significant errors to occur in the measurements. Therefore, we recommend performing a preliminary deskew procedure and repeating it whenever you change to the physical characteristics of the probes or the bandwidth/filter settings of the input channels.

Likewise, Fine DC Adjust voltage channels to remove any residual charge that may be in the probes.

3. Select analysis type, tests to be performed, and measurements to be displayed

This step comprises most of the work you will do in the Power Analyzer Software. Once the source channels are set up, various tests can be performed on the same inputs. The software automatically calculates your selected power measurements and displays them on screen, with test-appropriate trace annotations and overlays to help you see significant portions of the input waveforms.

Power Analysis Software Dialogs

The Power Analysis Software presents a series of dialogs for setting up measurements specific to testing switched-mode power supplies and devices. Generally, the order of the tabs presents the order in which you proceed to use the software, working from left to right.

Power Analysis Dialog

The first tab is the Power Analysis dialog. This is the main set of controls where you select the **Voltage** and **Current Source** input channels, the **Analysis Type**, and the specific **Tests** to run.



The Power Analysis dialog is also where you control the display of Statistics or Histograms within the Power Analysis Measurements table, and Clear Sweeps to reset the measurement counter.

Quickly return to the Power Analysis dialog from any other dialog by selecting the leftmost section of the Power Analysis measurement table.

Device	TurnOn	Conduction	TurnOff	Offstate
value	3.6114017 µJ	1.9672963 µJ	3.9521554 µJ	3.5933410 µJ
mean	3.689251673 µJ	1.766332420 µJ	6.153658590 µJ	-179.951849 nJ
min	3.4602253 µJ	921.8813 nJ	1.9540425 µJ	-4.7064163 µJ
max	4.8248591 µJ	2.6779545 µJ	8.0828663 µJ	3.2923410 µJ
stdv	95.217378 nJ	799.941756 nJ	1.810404775 µJ	1.411018584 µJ
max	654	654	654	436

Input Settings Dialog

The second tab opens the Input Settings dialog, which allows you to adjust the **Fine DC Offset** and **Deskew** values of your probes to increase measurement accuracy.

You can view the *result* of adjusting Fine DC Offset and Deskew by checking **View** on the Input Settings dialog. This is a convenience to assist with fine adjustment; it's not necessary to keep this trace open. Deskew values are duplicated on the Channel dialog, and the Power Analysis Software incorporates the Fine DC Offset value in its measurement results.

You also use the Input Settings dialog to select the type of device used to measure current in **ProbeType**.

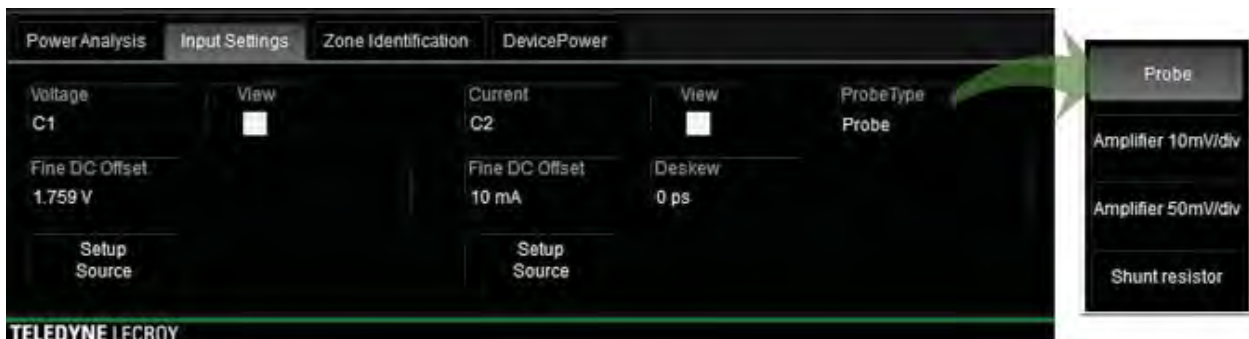

Setup Source buttons on the Input Settings dialog enable you to quickly access the source Channel setup dialogs, where you can adjust input bandwidth limits, set up filters, AutoZero voltage probes, or DeGauss current probes.

NOTE: When selecting Device Analysis, Losses Test and a Conduction Loss calculation method measuring Vsat with a 2nd voltage probe, a third set of controls will become available for Deskew and DC Fine Adjust. These controls are made available for use with a probe or amplifier solution that incorporates voltage clamping and fast overdrive recovery, such as the DA1855A/DXC100A.

Zone Identification Dialog

This tab appears only when the Analysis Type is Device. The Zone Identification dialog is used to set up device switching measurement zones, which adds a set of color overlays and annotations to the Power Analysis trace.



Other Dialogs

Tabs for Device Power, Control Loop, and Line Power dialogs appear only when the respective Analysis Type is selected. They contain rescale controls that allow you to “zoom” the Power Analysis trace to view more or less waveform detail . The controls are the same as found on any Zoom dialog, although in this case they will alter the appearance of the Power Analysis trace instead of opening a new zoom trace.

Deskew Voltage and Current Channels

Use this Deskew procedure to check propagation delay differences between the current and voltage channels. This is very important if these signals are going to be used to make instantaneous power Losses, Safe Operating Area, or Dynamic On-resistance measurements.

This process can be used to characterize and correct the delay difference between more than one current and one voltage channel. For instance, if you plan to use one voltage channel and alternate measurements between two current channels, the relationship between the voltage channel and each of the current channels can be characterized. The same is true if you are using a differential amplifier to capture voltage at key event points. The amount of deskew required for each combination should be recorded for later use.

Throughout this procedure, the Voltage source channel is used as the reference trace. Adjust all other traces to this reference.

1. Recall the oscilloscope's factory default settings.
2. Connect the:
 - Voltage probe to Channel 1
 - Current probe to Channel 2
 - DCS015 Deskew Calibration Source to the EXT input.
3. Set **Channel 1 scale to 1 V/div**. If using a differential probe on Channel 1, also **AutoZero** the probe.
4. Set **Channel 2 scale to 20 mA/div**. **DeGauss** the current probe.

NOTE: It's good practice to leave the current probe disconnected from the test circuit due to the excitation signal used to DeGauss the probe.

5. Connect the voltage and current probes to the DCS015. Be sure to match the proper voltage probe polarization and current probe direction to the DCS015.
6. Set the oscilloscope **timebase to 20 ns/div** and zero delay.
7. Set the oscilloscope **trigger to Channel 1, negative edge, at a level of 2 Volts**.
8. Choose **Display > Single Grid**, then **adjust Offset** on Channel 1 and Channel 2 so that the voltage and current waveforms are on top on each other in the middle of the display.

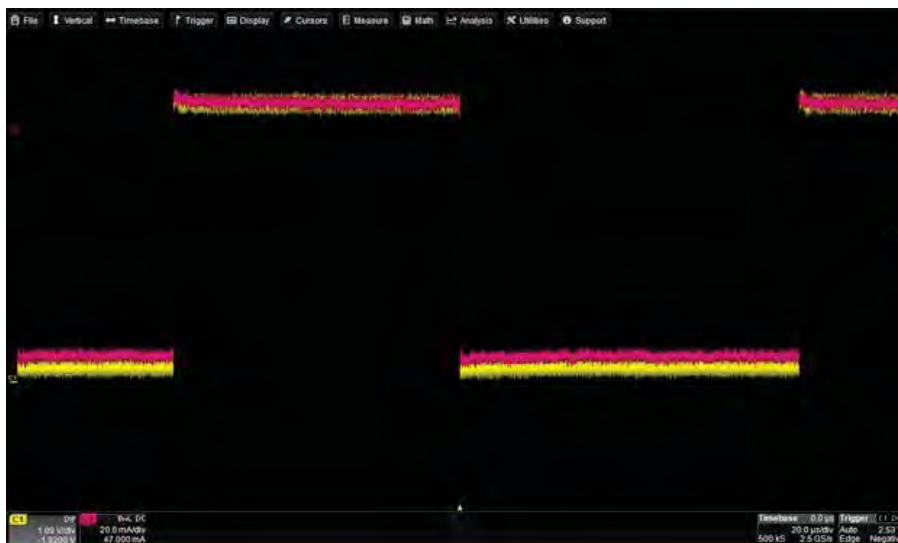

9. Choose **Analysis > Power Analysis** to open the Power Analysis Software.
10. On the Power Analysis dialog, select C1 as the **Voltage source**, and C2 as the **Current source**.
11. On the Input Settings dialog, adjust the Current **Deskew** value until the slope of the current probe intersects the voltage waveform at the 50% peak-to-peak level.

TIP: You can do this by selecting the Deskew field, then turning the Front Panel Horizontal knob.
12. Repeat the deskew procedure for the differential amplifier or any other probes you have connected to other channels.

NOTE: The Deskew values you obtain using this procedure are only valid for this particular setup. It is recommended to repeat the deskew procedure if you change probes, cables, or bandwidth/filter settings on any channel.



Falling edge of voltage and current traces before deskew adjustment.

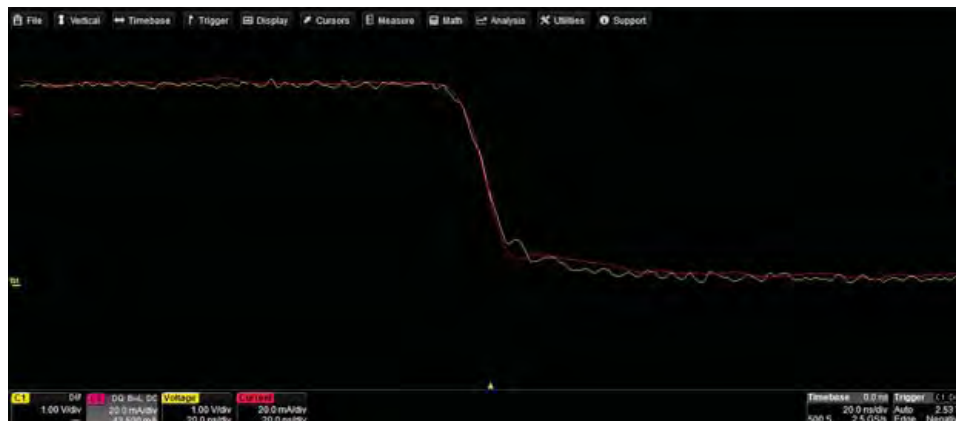

Falling edge of voltage and current traces after deskew adjustment.

Power Device Analysis

Preliminary Setup

The Device Analysis tests let you make difficult measurements on devices while they operate in circuit. The exact setup for each measurement will differ depending on what device type is to be analyzed and where it is located in the circuit.

Test Circuit Setup

Examples in this section are based on connections to an off-line flyback power supply circuit. Measurements are made on devices such as power transistors, snubber diodes, or similar devices in other topologies.

A typical setup used to analyze the power MOS-FET in an off-line switching power supply is:

- A differential high-voltage probe is connected to V_{ds} on the oscilloscope's Channel 1.
- A current probe is connected to the drain current, I_d , using a current loop into Channel 2.
- A differential amplifier, with a matched differential probe pair, is used to connect to either V_{ds} or V_{gs} into Channel 3. This amplifier will need to have voltage clamping and fast over drive recovery in order to see the saturation voltage and have high CMRR to capture the high-side gates in an off-line application.

The example in the figure below uses the oscilloscope's Channel 4 to acquire a trigger signal indicating when the load changes from maximum to minimum. You could also use the oscilloscope's EXT trigger input.

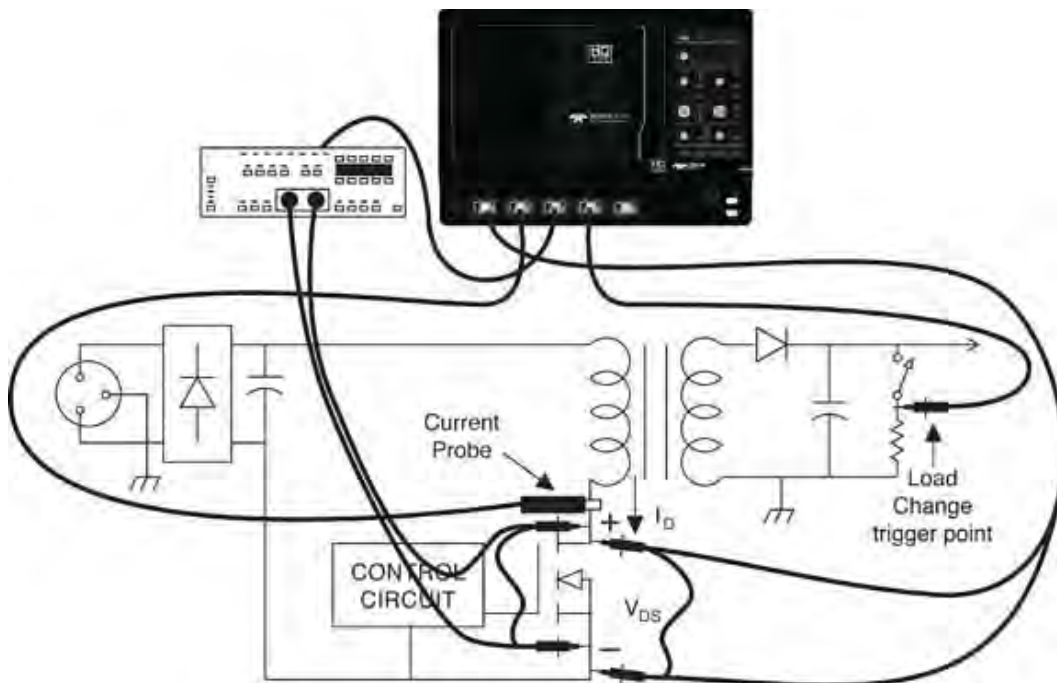

Typical probing points for device analysis.

Trigger Setup

Triggers for Device analysis are generally associated with a load change or on/off event in the circuit.

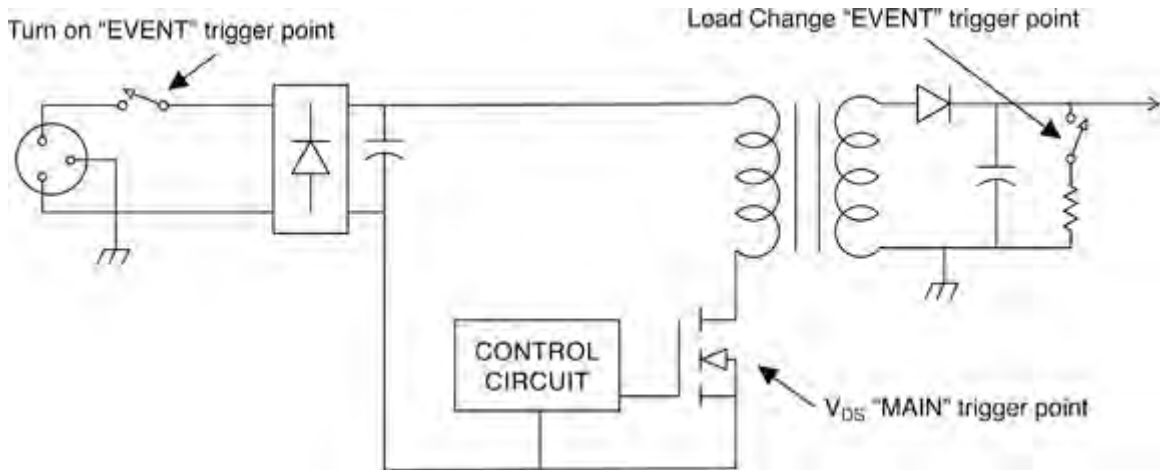

Typical trigger points for device analysis.

Obtain a stable display of at least one cycle of the voltage signal across the device.



Set Up Device Analysis Input Channels

This procedure selects the voltage and current source channels and makes any necessary offset or deskew adjustments to ensure measurement accuracy.

If you have just completed the preliminary deskew procedure, begin at Step 6.

1. From the menu bar, choose **Analysis > Power Analysis** to open the Power Analysis dialog.
2. Check **Enable**.
3. Select the **Voltage Source** channel where the voltage probe is attached.
4. Select the **Current Source** channel where the current probe is attached.

NOTE: The current input channel is automatically assigned Ampere units.

5. Touch the **Input Settings** tab and enter the current probe **Deskew** value obtained during the preliminary deskew procedure.
6. Choose the current **ProbeType**. If you're using a current device other than a probe (e.g., shunt resistor), also make these entries:
 - **If an amplifier**, also enter the **Amps/div**.
 - **If a shunt resistor**, also enter Shunt Resistor **Ohms**.
7. If necessary, touch **Select Source** and make any final adjustments on the voltage or current Channel setup dialogs.

NOTE: If you change the probe, bandwidth or filter settings at this point, repeat the [preliminary deskew procedure](#) and re-adjust the Deskew setting on the Input Settings dialog.

8. Choose **Display > Auto Grid** and set up peak-to-peak waveforms to utilize the full Analog-Digital Converter (ADC). The waveform should cover the full height of the grid.
9. When you have obtained a stable display, go on to [identify the switching zone](#).

Identify Switching Zone

This procedure instructs the software how to recognize the transition event in the device power trace (e.g., ON to OFF) and focus the analysis on it. To do this, you'll define the vertical area of interest (Signal Top and Base) and the horizontal area of interest (Transition Threshold) as a measure of voltage.

1. [Set up the source channels.](#)
2. Touch the **Zone Identification tab** and choose a **Top Base Value** of either:
 - **TopBase**-- analyze the entire waveform top (mean of all max. V) to base (mean of all min. V)
 - **Levels**—analyze only voltages between this absolute Top Level and Base Level



3. Choose whether the transition **Thresholds Are** given as a **Percent** of signal or **Absolute** values, and enter the **High Threshold** and **Low Threshold** representing the starting voltage and ending voltage that marks the transition event in the waveform.

Overlays appear on the voltage trace marking the Conduction, On, and Off states, similar to this:

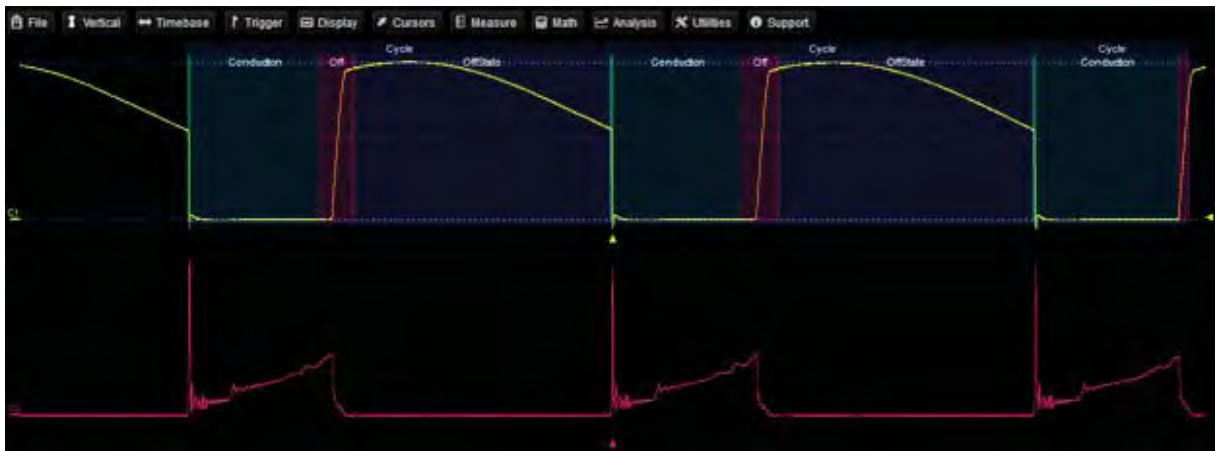

Go on to perform your desired Device Analysis tests.

Device Losses Test

This test measures switching device power losses as:

- Mean power—Watts
- Peak power—instantaneous peaks in Watts
- Energy—Watts/seconds in Joules

1. [Select the source channels](#) and [identify the switching zone](#).
2. On the Power Analysis tab choose **Analysis Type Device** and **Test Losses**.
3. Select the **Measurements** to calculate. Options are:

- Switching losses – losses from switch between states
- Conduction loss—loss from internal resistance
- Offstate losses—losses during the off state due to instrumentation as noted below

NOTE: Offstate loss in discontinuous power devices is typically zero, and any value is probably due to residual DC in the current probe. Therefore, this measurement is useful for fine adjusting the current probe. Adjust the Fine DC Offset field of current probe input settings until the measured Offstate loss value is as close to zero as possible (ideally in Nano Joules).

- Sum—total measured losses over entire switching cycle
4. If you have selected to calculate Conduction Loss, choose the conduction **Calculation Method**. Options are:
 - **Std. Probe Inputs**—Select if you are using only the standard two probes.
 - **2nd Voltage Probe**—Select if you are using a differential amplifier (or 2nd voltage probe) to measure saturation voltage at the event site. Select the Voltage Source channel where the amplifier is connected.
 - **MOSFET Rds(on) Value**—Best if your circuit is a MOSFET and you know the Resistance of the conductor. Enter the value in Ω .
 - **IGBT Vce(sat) Value**—Best if your circuit is an IGBT and you know the Saturation Voltage. Enter the value in V.

Readouts for the selected measurements appear in a table below the grid area.



5. Choose to display the measured **Mean Power**, **Peak Power**, or **Energy (Joules)**.
6. Optionally, select **Statistics** to display mean, minimum and maximum values on the measurements table. This helps to observe a consistent number.
7. Optionally, select **Histograms** to display a miniature histogram of the statistical measurements.
8. If your readout shows positive conduction values when the circuit is in the OFF state, touch the **Input Settings tab** and enter a **Fine DC Offset adjustment** value to compensate for any residual DC values in the probes, until conduction is as close to zero as possible.

Device Safe Operating Area Test

This test measures that voltage, current, and power of an event all fall within safe operating levels as defined by EN 6000-3-2.

1. [Select the source channels](#) and [identify the switching zone](#).
2. On the Power Analysis tab choose **Analysis Type Device** and **Test Safe Operating Area**.

The drain-to-source voltage waveform is displayed on the first grid, and the deskewed current waveform is displayed on the second grid.



On the XY plot in the third grid, voltage points are plotted on the horizontal axis, while current is plotted on the vertical. The bottom left corner of the XY trace is the 0,0 point; the top of the trace is maximum current; far right of the trace is maximum voltage. The most frequently occurring samples are marked by a red intensity display.

3. Optionally, select **Statistics** to display mean, minimum and maximum values on the measurements table. This helps to observe a consistent number.
4. Optionally, select **Histicons** to display a miniature histogram of the statistical measurements.

Device B-H Curve Test

This test displays the B-H hysteresis plot that confirms the saturation status of a magnetic device. The voltage across a waveform, typically acquired with a differential voltage probe, is set as the voltage source. The current through the device is captured typically with a current probe. The hysteresis plot is presented as the integrated voltage across the magnetic device versus the current through the device.

1. [Select the source channels](#) and [identify the switching zone](#).
2. On the Power Analysis tab choose **Analysis Type Device** and **Test B-H Curve**.

The scope display shows the voltage source before it is integrated, the current source, and the hysteresis plot.

TIP: To see the integrated voltage waveform, create a Math function trace using the Integral operator applied to the voltage source channel.

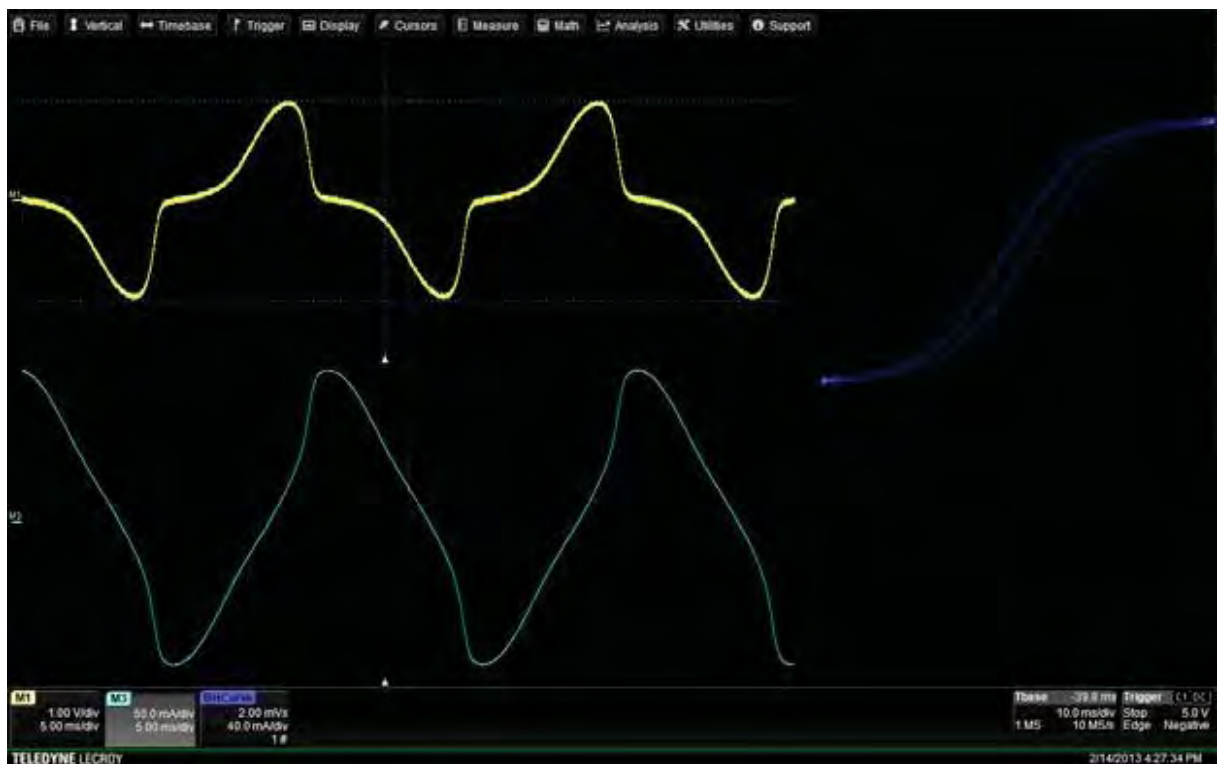

Device Dynamic On-resistance Test

This test measures resistance to the current when the device is turned on. A DA1855A differential amplifier and DXC100A passive differential probe pair are recommended to run this test.

1. [Select the source channels](#) and [identify the switching zone](#).
2. On the Power Analysis tab choose **Analysis Type Device** and **Test Rds(on)**.

The deskewed voltage (V) and current (I) waveforms are displayed on the first grid.

3. Adjust voltage trace **Scale (V/div)** and **trigger Level** until the voltage waveform displayed is the device saturation voltage.

The voltage waveform is divided by the deskewed current waveform, and the resulting Resistance waveform trace is displayed on the third grid.

NOTE: Because the device saturation voltage waveform is off screen during the non-saturation portion of circuit, the math-generated resistance waveform should be ignored during this time.



4. Optionally, select **Statistics** to display mean, minimum and maximum values on the measurements table. This helps to observe a consistent number.
5. Optionally, select **Histograms** to display a miniature histogram of the statistical measurements.

Device dv/dt Test

This test measures the speed of a power device's rate of change (dv/dt) during turn-on and turn-off.

1. [Select the source channels](#) and [identify the switching zone](#).
2. On the Power Analysis tab choose **Analysis Type Device** and **Test dv/dt & di/dt**.
3. Select di/dt by checking the **di/dt box** in the Waveform section.

The power device's drain-to-source voltage (VDS) signal and the drain current are displayed on the first grid. The derivative of the waveform's dv/dt is displayed on the second grid. The di/dt waveform is shown in the third grid.



4. Optionally, enter an **Enhance Bit Value** in the Setup section. This applies a filter to the data to reduce noise.
5. Optionally, select **Statistics** to display mean, minimum and maximum values on the measurements table. This helps to observe a consistent number.
6. Optionally, select **HistIcons** to display a miniature histogram of the statistical measurements.

Control Loop Analysis

Preliminary Setup

Switched-mode power conversion circuits use some method of transferring energy from an unregulated source to regulated outputs on a cycle-by-cycle basis. Output regulation is achieved by modulating the amount of energy transferred in each cycle, the most common method being Pulse Width Modulation (PWM). Other methods (such as frequency modulation) are also used, but no matter which method is used, it is difficult to view and analyze the modulation.

Control Loop analysis provides you with tools to view the information contained in the control circuit's modulated signals. It does this by taking the time (duty cycle or width) information in the modulated signal that is normally displayed on the horizontal axis, along with elapsed time, and displays it on the vertical axis.



As the number of pulses per division increases, the display of their individual widths forms a “waveform” that represents the change in pulse width (or other characteristic) as a function of elapsed time. This “waveform” can be used to gain valuable information about the power supply’s response to various events, such as load change (step response) or its soft-start performance.

Test Circuit Setup

Control Loop Analysis lets you capture and analyze information contained in the power conversion circuit’s modulation. The exact setup for this measurement will differ depending on the specific circuit topology and where in the circuit under test the modulation signal is to be acquired.

Examples in this section are based on a typical setup to acquire the modulated signal at the power MOS-FET’s gate in an off-line switching power supply, as shown in the image below.

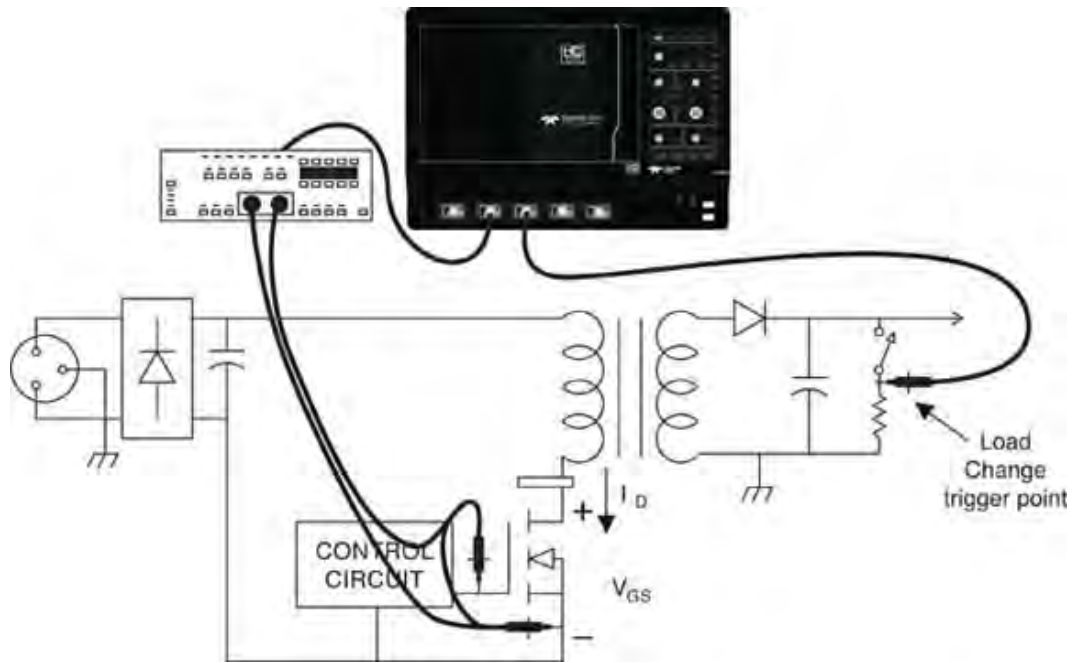

Typical control loop analysis circuit setup

To maintain isolation from the oscilloscope, the Teledyne LeCroy DA1855A Differential Amplifier is used to acquire the device's gate control signal. Other signals in the circuit can be used to measure the modulation, but the feedback loop is usually a good place to acquire a relatively noise-free signal.

Trigger Setup

Control Loop analysis measurements usually are made to find the circuit's response to some event. Turn-on, turn-off, line trigger, or load change can be used to trigger the modulated signal acquisition. In the example below, a load change on the output is used as the event trigger, and the power transistor's gate control signal is used as the source of modulation information.

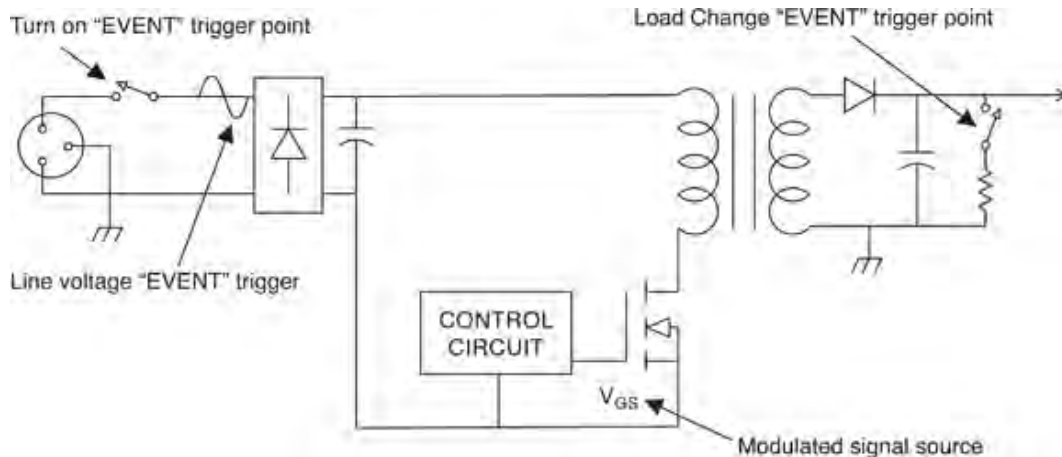

Typical control loop analysis triggers

When setting up the Control Loop trigger:

- Set up a stable display of the signal that will be used as the source of the modulation information. Ensure that a clean signal can be acquired that will allow the signal's width (or other characteristic) to be readily measured.
- If the modulated signal is to be acquired as the result of a one-time event such as turn-on, test the trigger for satisfactory operation in Single trigger mode. If the event is repetitive, you can use the oscilloscope's Normal trigger.
- Be sure to set trigger Delay and Time/div to a value that will allow the capture of a modulated signal record sufficiently long to cover the time of interest.

Set Up Control Loop Analysis Source Channel

This procedure selects the voltage source channel and makes any necessary offset or deskew adjustments to ensure measurement accuracy.

If you have just performed the preliminary deskew procedure, begin at Step 5.

1. From the menu bar, choose **Analysis > Power Analysis** to open the Power Analysis dialog.
2. Check **Enable**.
3. Select the **Voltage Source** channel where the voltage probe is attached.
4. If you are using a current device to trigger on a load change event:
 - Touch the Input Settings tab and enter the **Deskew** value obtained during the preliminary deskew procedure.
 - Choose **ProbeType**.
 - If the current device is other than a probe (e.g., shunt resistor), also make these entries:
 - If an **amplifier**, also enter the **Amps/div**.
 - If a **shunt resistor**, also enter Shunt Resistor **Ohms**.
5. Adjust **Fine DC Offset** to zero the level.
6. If necessary, touch **Select Source** and make any final adjustments on the voltage or current Channel setup dialogs.

NOTE: If you change the probe, bandwidth or filter settings at this point, repeat the [preliminary deskew procedure](#) and re-adjust the Deskew setting on the Input Settings dialog.

Obtain a stable display of at least one cycle of the voltage signal across the device, then go on to perform your desired tests.

[Closed Loop Test](#)

Closed Loop Test

1. [Set up the source channel.](#)
2. On the Power Analysis tab choose **Analysis Type Control Loop** and **Test Closed Loop**.
3. Choose the **Operator** (method) used to modulate the signal. This is the input signal parameter that will be used to generate the Closed Loop trace.
4. Choose the **Slope** (Pos. or Neg.) on which to measure.
5. Touch the **Level Is** field and select to enter the measurement voltage Level as an Absolute Value, Percentage (of top to base), or one of the percent ranges.
6. Enter the absolute or percentage of **voltage Level** at which to measure the operator. Set this to a level on the modulated signal where both the rising and falling edges are free of noise.

TIP: When measuring the modulation of the gate drive signal, it is best to avoid placing the level around the pedestal.

OR

Touch the **Find Level button** to let the software set Level based on the amplitude of the acquired gate signal.

The modulated signal is displayed in the first grid. The Closed Loop trace that results from measuring each modulation is displayed in the second grid.



Line Power Analysis

Preliminary Setup

The Line Power Analysis section of PAS provides you with tools to measure 50 and 60 Hz line voltage (Vrms), line current (Irms), Apparent Power (VA), Real Power (Watts), and Power Factor ($\cos \theta$). It also enables you to evaluate harmonic currents injected into the power line. Harmonic measurements are made in accordance with the requirements of standard EN 61000-3-2, Harmonic Current Emissions. Teledyne LeCroy encourages you to refer to the latest version of EN 61000-3-2 for full definitions and limits set forth by the standard. The information here is abstracted for your convenience.

Test Circuit Setup

In the examples in this section, Channel 2 is used for voltage and Channel 3 is used for current, but any channel could be used for voltage or current. In the case of 3-phase systems, multiple voltage and/or current channels can be set up before analysis is started.

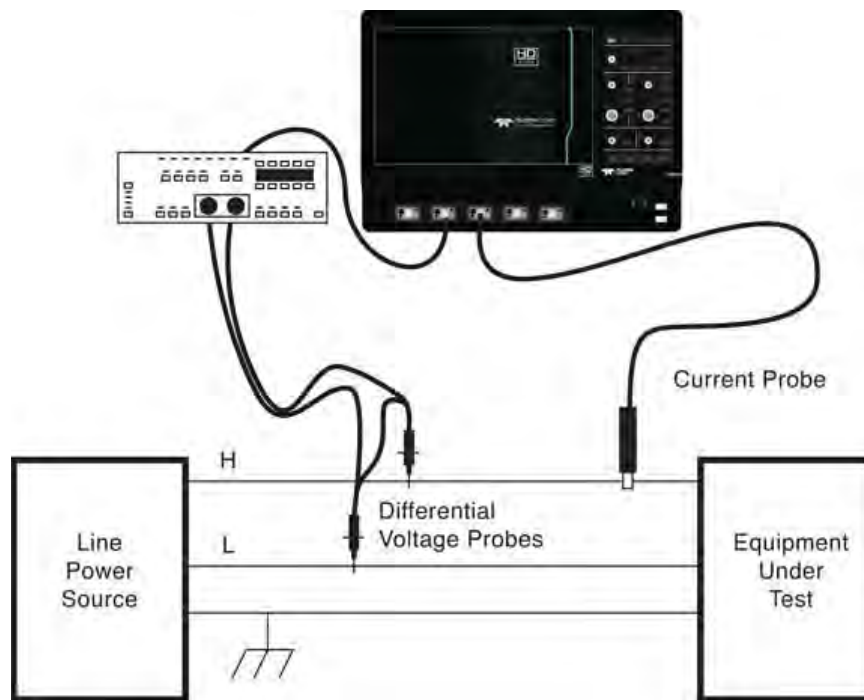

Typical line power analysis circuit setup

The line power source should be low distortion. EN 61000-3-2 specifies maximum harmonic distortion for the power source while it is connected to the equipment under test. The test can be run with the available power line, but the distortion in the source will directly affect the quality of the measurements.

The current waveform polarity must match that of the voltage waveform. Make sure your current probe is connected so that this is the case.

Trigger Setup

Triggers for Line Power tests can be set on differential voltage, current signal, or line signal depending on what you need to measure.

Set Up Line Power Analysis Source Channels

This procedure selects the voltage and current source channels and makes any necessary offset or deskew adjustments to ensure measurement accuracy.

If you have just completed the preliminary deskew procedure, begin at Step 6.

1. From the menu bar, choose **Analysis > Power Analysis** to open the Power Analysis dialog.
2. Check **Enable**.
3. Select the **Voltage Source** channel where the voltage probe is attached.
4. Select the **Current Source** channel where the current probe is attached.

NOTE: The current input channel will be assigned Ampere units even if a voltage probe or a non-Probus probe is used.

5. Touch the **Input Settings** tab and enter the **Deskew** value obtained during the preliminary deskew procedure.
6. Choose the **ProbeType**. If you're using a current device other than a probe (e.g., shunt resistor), also make these entries:
 - **If an amplifier**, enter the **Amps/div**.
 - **If a shunt resistor**, enter Shunt Resistor **Ohms**.
7. Adjust **Fine DC Offset** to zero the level.
8. If necessary, touch **Select Source** and make any final adjustments on the voltage or current Channel setup dialogs.

NOTE: If you change the probe, bandwidth or filter settings at this point, repeat the [preliminary deskew procedure](#) and re-adjust the Deskew setting on the Input Settings dialog.

Obtain a stable display of at least one cycle of the voltage signal across the device, then go on to perform your desired tests.

[Line Power Test](#)

[Line Harmonics Test](#)

Line Power Test

This test analyzes the line current, voltage, power, and power factor of the device under test.

1. [Set up the source channels.](#)
2. On the Power Analysis tab choose **Line Power Analysis**, and **Power Test**

The display shows the line voltage and current waveform, as well as the power and energy waveforms. Parameters displayed are rms voltage, rms current, real power, apparent power (apwr) and power factor (pf).



Line Harmonics Test

This test checks the line harmonics to see if they meet EN 6000-3-2 compliance levels.

TIP: To speed up processing, set the sampling rate to 50 kS/s. This will yield a frequency over the required maximum frequency of 2.4 KHz (40 times the fundamental line frequency of 50, 60 Hz). Touch the Timebase descriptor box to open the Timebase dialog; select Fixed Sampling Rate and enter a Sampling Rate of 50 kS/s.

1. [Set up the source channels.](#)
2. On the Power Analysis dialog choose **Line Power Analysis** and **Harmonics Test**.
3. Touch **Class** and select the equipment's EN 61000-3-2 classification from the pop-up menu:
 - **Class A**, Balanced three-phase equipment, household appliances (excluding those in class D), non-portable tools, audio equipment, dimmers for incandescent lamps, and all other equipment except that stated in one of the following classes
 - **Class B**, Portable tools, non-professional arc welding equipment
 - **Class C**, Lighting equipment (except dimmers)
 - **Class D**, Personal computers and computer monitors, radio or TV receivers (75W-600W)
4. Touch **Units** and select Amps or dBuA (decibels referred to one microAmp).
5. Touch **Frequency** and select the line frequency at which the equipment is operating. You can optionally choose to Use Measured Frequency to enter the value as measured by the current probe.

A table of measured results appears above the Power Analysis dialog, with the Line Harmonics trace in the third grid.



6. Optionally, move the cursor along the Line Harmonics trace to see the readout in the measurements table. To do this:
 - Stop acquisition by pressing the front panel **Stop trigger** button.
 - Turn the front panel **Cursor knob** or touch-and-drag the white cursor line to move the cursor.