

# Alpha COND 500

Controller/Transmitter  
uS / mS / °C



**Thermo**

ROSS and the COIL trade dress are trademarks of Thermo Fisher Scientific Inc. U.S. patent 6,793,787.

AQUAfast, Cahn, ionplus, KNIpHE, No Cal, ORION, perpHect, PerpHecT, PerpHecTion, pHISA, pHuture, Pure Water, Sage, Sensing the Future, SensorLink, ROSS, ROSS Ultra, Sure-Flow, Titrator PLUS and TURBO2 are registered trademarks of Thermo Fisher.

1-888-pHAX-ION, A+, All in One, Aplus, AQUAsnap, AssuredAccuracy, AUTO-BAR, AUTO-CAL, AUTO DISPENSER, Auto-ID, AUTO-LOG, AUTO-READ, AUTO-STIR, Auto-Test, BOD AutoEZ, Cable-Free, CERTI-CAL, CISA, DataCOLLECT, DataPLUS, digital LogR, DirectCal, DuraProbe, Environmental Product Authority, Extra Easy/Extra Value, FAST QC, GAP, GLPcal, GLPcheck, GLPdoc, ISEasy, KAP, LabConnect, LogR, Low Maintenance Triode, Minimum Stir Requirement, MSR, NISS, One-Touch, One-Touch Calibration, One-Touch Measurement, Optimum Results, Orion Star, Pentrode, pHuture MMS, pHuture Pentrode, pHuture Quatrode, pHuture Triode, Quatrode, QuiKcheK, rf link, ROSS Resolution, SAOB, SMART AVERAGING, Smart CheK, SMART STABILITY, Stacked, Star Navigator 21, Stat Face, The Enhanced Lab, ThermaSense, Triode, TRIUMpH, Unbreakable pH, Universal Access are trademarks of Thermo Fisher.

Guaranteed Success and The Technical Edge are service marks of Thermo Fisher.

PerpHecT meters are protected by U.S. patent 6,168,707. PerpHecT ROSS electrodes are protected by U.S. patent 6,168,707. ORION Series A meters and 900A printer are protected by U.S. patents 5,198,093, D334,208 and D346,753. ionplus electrodes and Optimum Results solutions are protected by U.S. patent 5,830,338. ROSS Ultra electrodes are protected by U.S. patent 6,793,787. ORP standard is protected by U.S. patent 6,350,367. No Cal electrodes are protected by U.S. patent 7,276,142. © 2009 Thermo Fisher Scientific Inc. All rights reserved. All trademarks are the property of Thermo Fisher Scientific Inc. and its subsidiaries. The specifications, descriptions, drawings, ordering information and part numbers within this document are subject to change without notice. This publication supersedes all previous publications on this subject.

## **Preface**

This manual serves to explain the use of the Alpha COND 500 transmitter. It functions in two ways, firstly as a step by step guide to help you to operate the transmitter. Secondly, it serves as a handy reference guide. It is written to cover as many anticipated applications of the transmitter as possible. If there are doubts in the use of the transmitter, please do not hesitate to contact the nearest Authorized Distributor.

Thermo Scientific will not accept any responsibility for damage or malfunction to the transmitter caused by improper use of the instrument.

The information presented in this manual is subject to change without notice as improvements are made, and does not represent a commitment on the part of Thermo Scientific.

Copyright © 2009

All rights reserved

## **TABLE OF CONTENTS**

<b>1</b>	<b>INTRODUCTION .....</b>	<b>1</b>
<b>2</b>	<b>PREPARATION .....</b>	<b>2</b>
2.1	POWER SUPPLY REQUIREMENTS (SL2 POSITION).....	3
2.2	CONNECTING THE ELECTRODE AND TEMPERATURE SENSOR (SL1 POSITION) ....	3
<b>3</b>	<b>INSTALLATION .....</b>	<b>5</b>
3.1	MECHANICAL DIMENSIONS .....	5
3.2	WALL MOUNT .....	5
3.3	PANEL MOUNT .....	6
<b>4</b>	<b>DISPLAY AND KEYPAD FUNCTIONS .....</b>	<b>7</b>
4.1	DISPLAY .....	7
4.2	KEYPAD .....	8
<b>5</b>	<b>CALIBRATION .....</b>	<b>9</b>
5.1	IMPORTANT INFORMATION ON TRANSMITTER CALIBRATION .....	9
5.2	TEMPERATURE CALIBRATION .....	11
5.3	CONDUCTIVITY CALIBRATION .....	12
<b>6</b>	<b>ADVANCED SETUP FUNCTIONS .....</b>	<b>13</b>
6.1	RANGE AND ZOOMING SELECTION SETTING.....	13
6.2	TEMPERATURE COMPENSATION SETTING .....	15
6.3	HOLD CURRENT SETTING.....	18
6.4	OUT-OF-RANGE CURRENT SETTING .....	18
6.5	TEMPERATURE COEFFICIENT AND NORMALIZATION TEMPERATURE SETTING ....	19
6.6	CELL CONSTANT SETTING .....	20
6.7	LINE RESISTANCE SETTING .....	20
6.8	VIEWING CALIBRATION POINT.....	21
6.9	VIEWING THE ELECTRODE DATA.....	21
6.10	RESET FUNCTION .....	22
<b>7</b>	<b>FACTORY DEFAULT SETTINGS .....</b>	<b>23</b>
<b>8</b>	<b>TROUBLE SHOOTING GUIDE.....</b>	<b>24</b>
<b>9</b>	<b>SPECIFICATIONS .....</b>	<b>25</b>
<b>10</b>	<b>ACCESSORIES .....</b>	<b>26</b>
<b>11</b>	<b>WARRANTY.....</b>	<b>27</b>
<b>12</b>	<b>RETURN OF ITEMS.....</b>	<b>27</b>

---

---

## 1 INTRODUCTION

---

---

Thank you for selecting an Alpha COND 500 2-Wire Transmitter. This isolated output 4-20mA transmitter is a sturdy microprocessor-based instrument that measures conductivity and temperature and transmits its output via the 2-wire power supply loop.

This transmitter has many user-friendly features – all of which are completely accessible through the water-resistant membrane keypad. Your transmitter includes an instruction manual and a warranty card.

Please read this manual thoroughly before operating your transmitter.

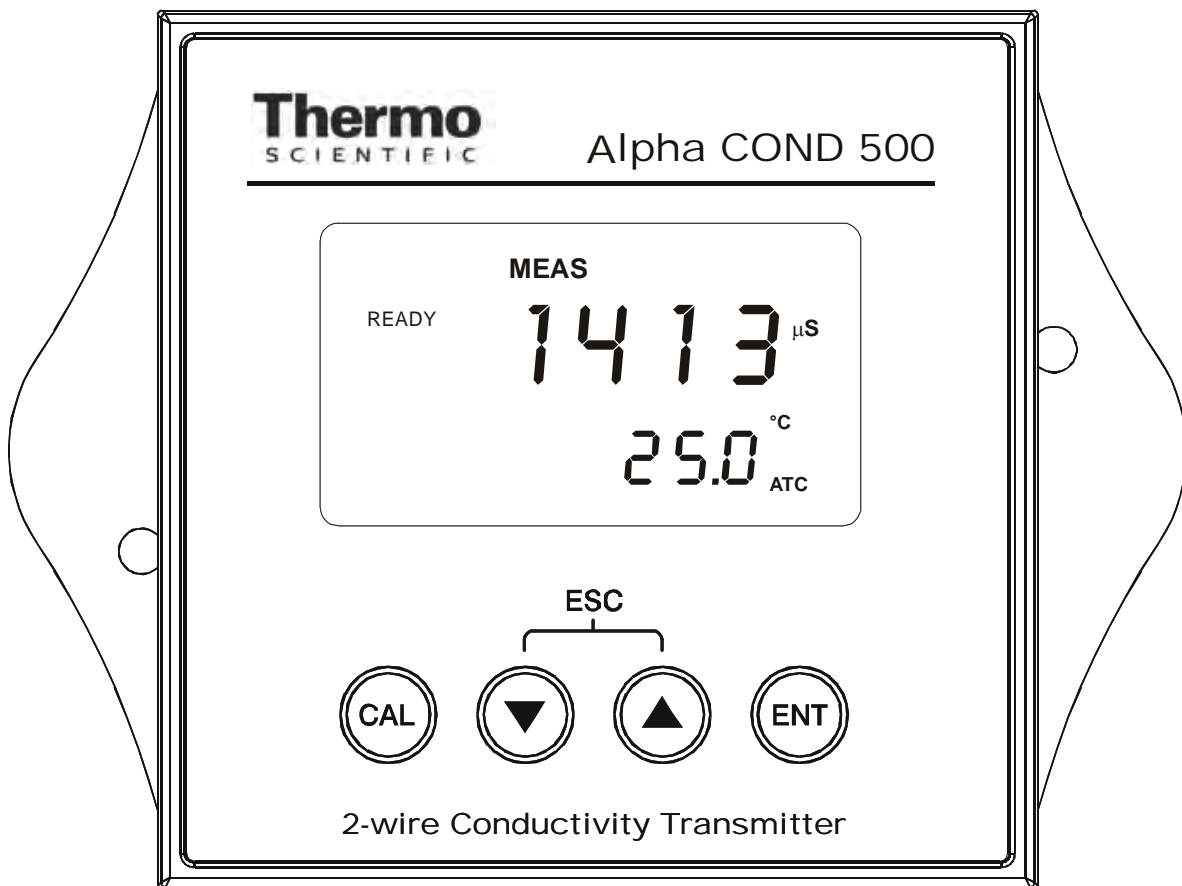

---

---

## 2 PREPARATION

---

---

Remove screws from the four corners at the back of the Transmitter, and remove back cover.

Connectors should be exposed as follows:

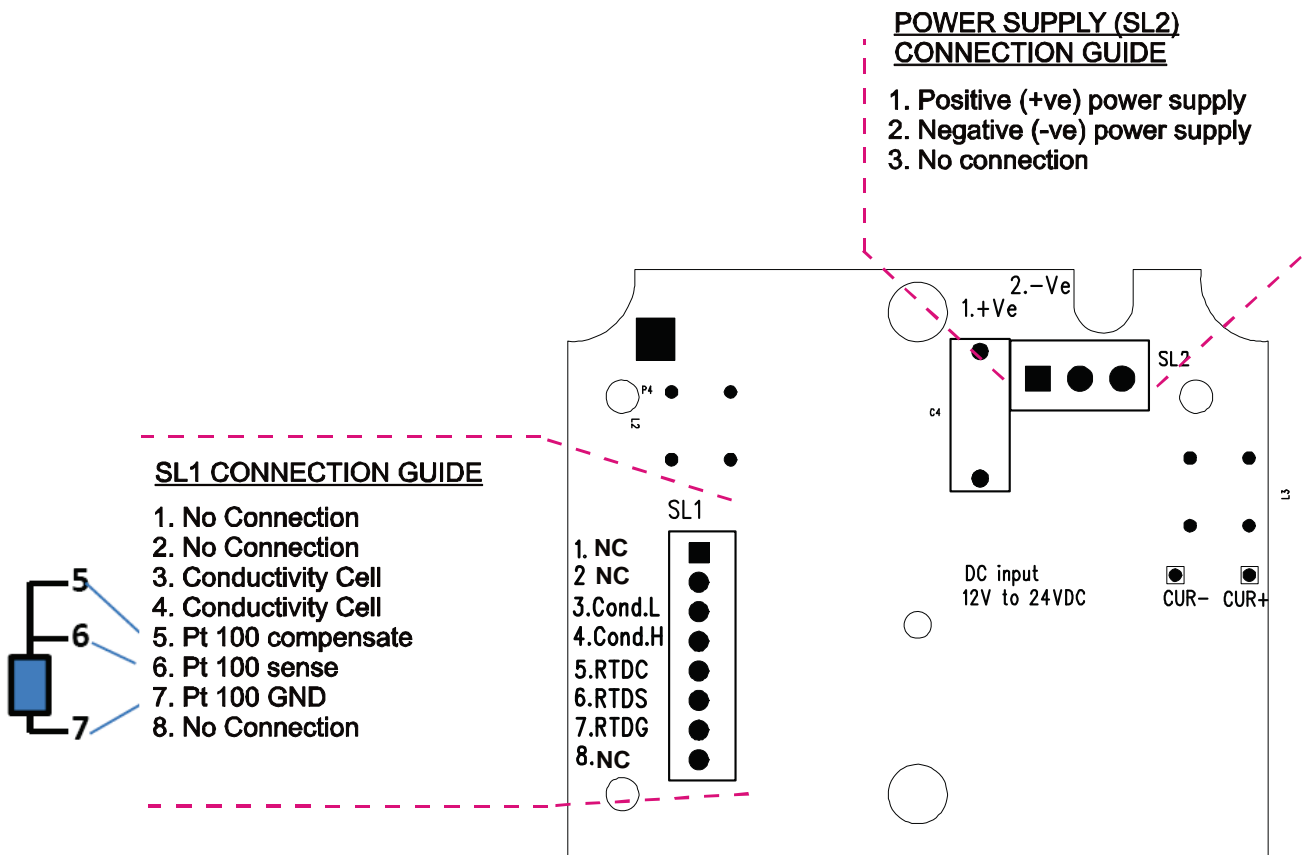

Figure 1 – Connection Guide

All wiring is done on 2 detachable connectors: –

1. 9-pin connector (located on SL1 position) for Conductivity electrode and temperature sensor; &
2. 3-pin connector (located on SL2 position) for power supply.

Using a suitable screwdriver, loosen screws from top of connector.

When inserting the wires, always hold connector with top screws facing up.

## 2.1 Power Supply Requirements (SL2 Position)

The Alpha COND 500 transmitter requires a 12 to 24V DC power supply. Other Transmitters and/or a chart recorder may be connected in the loop.

1. Insert positive loop wire from power supply to pin 1, tighten screw.
2. Insert negative loop wire to pin 2, tighten screw. This wire may be linked to a chart recorder or to negative terminal of power supply.

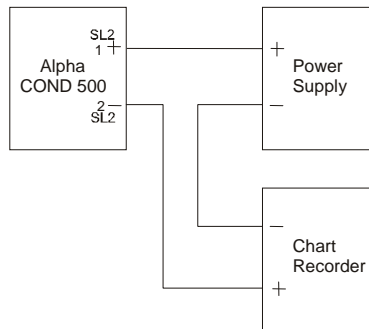

## 2.2 Connecting the Electrode and Temperature Sensor (SL1 Position)

### 2.2.1 To connect the Conductivity electrode:

The Alpha COND 500 transmitter accepts any industrial electrodes for conductivity measurements and they are usually offered with bare wires.

1. Insert the electrode's conductivity wire Low into pin 3 of SL1 connector. Tighten the screw.
2. Insert the electrode's conductivity wire High into pin 4 of SL1 connector. Tighten the screw.

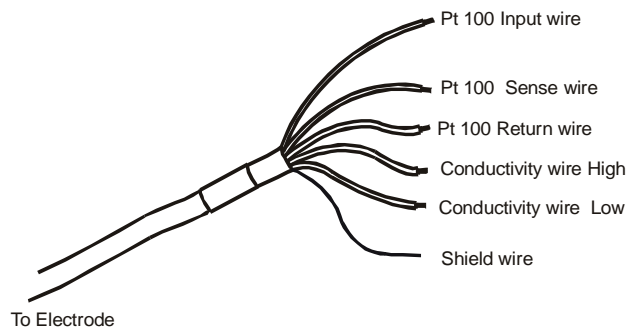

### 2.2.2 To connect ATC temperature sensor:

For Automatic Temperature Compensated (ATC) Conductivity readings, an in-built temperature sensor is usually integrated in the industrial conductivity electrodes. Otherwise, a separate 100Ω Pt RTD temperature probe can be used.

#### 3 wire temperature sensor

1. Insert the Pt100 input wire to pin 5 of SL1 connector. Tighten the screw.
2. Insert the Pt100 sense wire to pin 6 of SL1 connector. Tighten the screw.
3. Insert the Pt100 return wire and the shield wire to pin 7 of SL1 connector. Tighten the screw.

#### 2 wire temperature sensor

1. Take a small length of wire and short pins 5 and 6 of SL1 connector. Insert Pt 100 sense wire into pin 6 of SL1 connector and tighten the screws.
2. Insert Pt 100 return wire and the shield wire to pin 7 of SL1 connector. Tighten the screw.

***IMPORTANT: It is necessary to connect the SHIELD wire to the pin 7 as stated above to eliminate possible oscillation of the conductivity and/or temperature reading due to electrical noise or interference.***

***Ensure that no bare wires are exposed and all screws are tightened for proper contact.***

---

---

## 3 INSTALLATION

---

---

### 3.1 Mechanical Dimensions

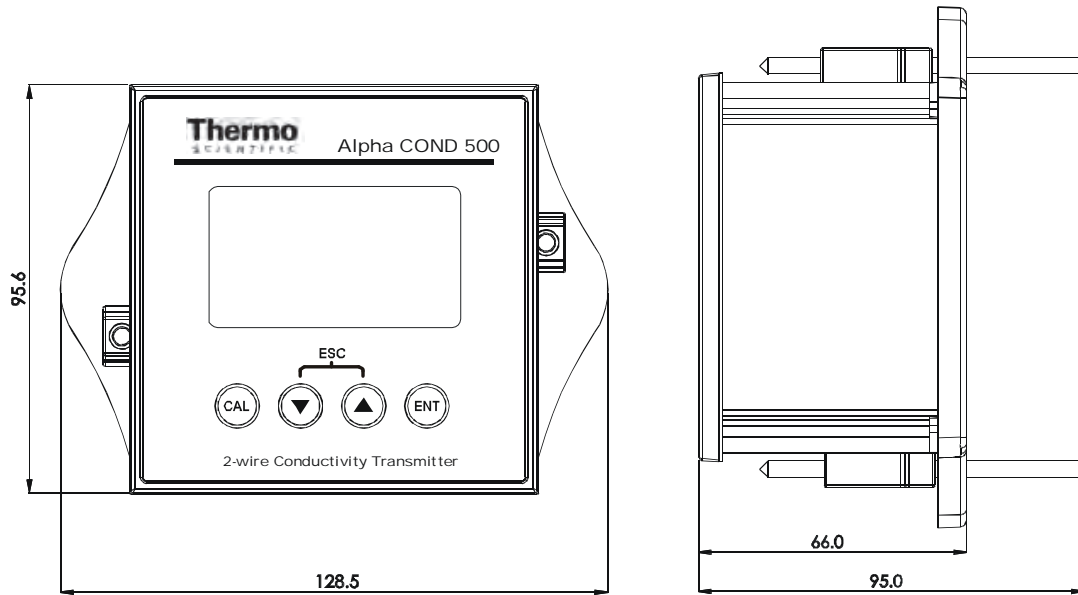

### 3.2 Wall Mount

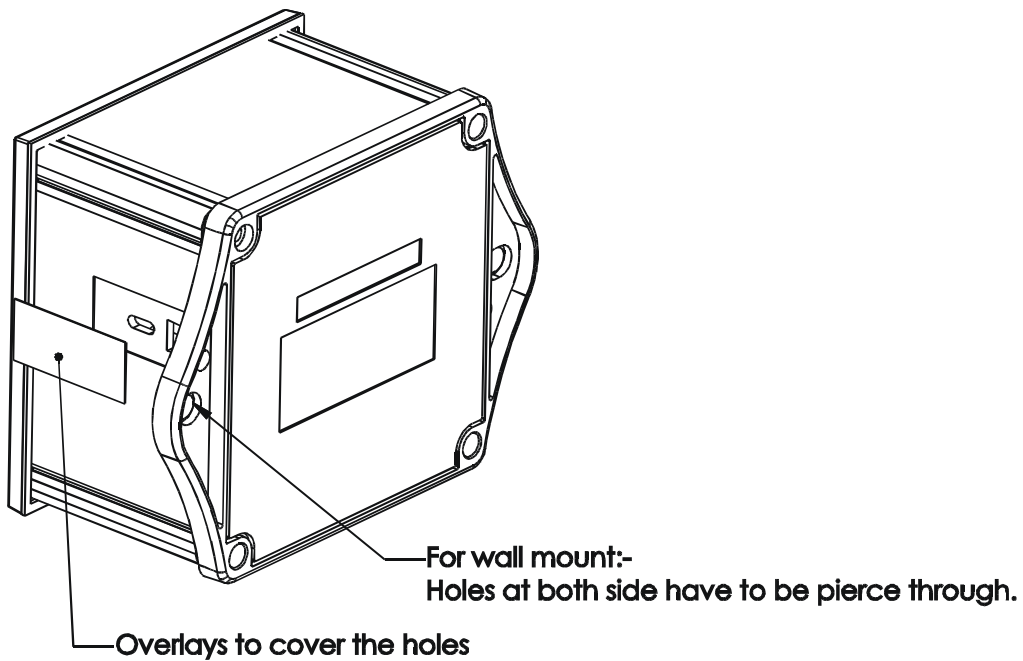

### 3.3 Panel Mount

1. Prepare panel cut-out of 92.0 mm by 92.0 mm

2. Remove back cover of transmitter and slide it through panel cut-out

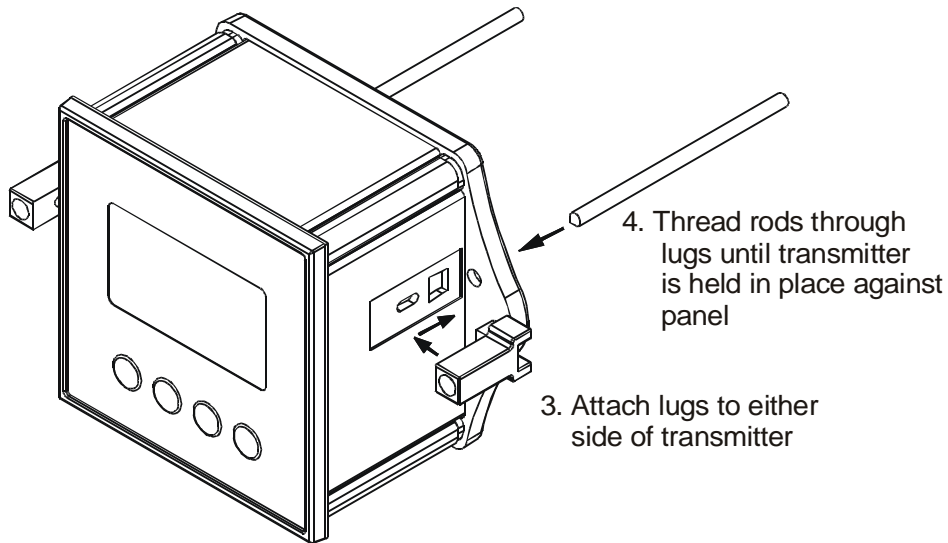
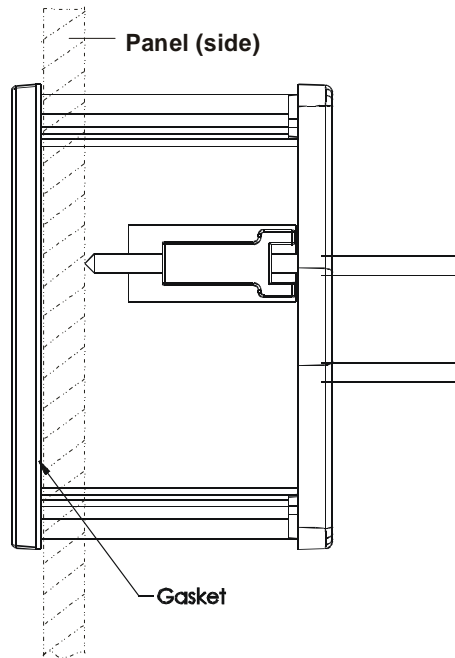

## 4 DISPLAY AND KEYPAD FUNCTIONS

### 4.1 Display

The LCD has a primary and secondary display.

- The primary display shows the measured conductivity value.
- The secondary display shows the measured temperature. In Calibration mode, measured conductivity values are displayed here.

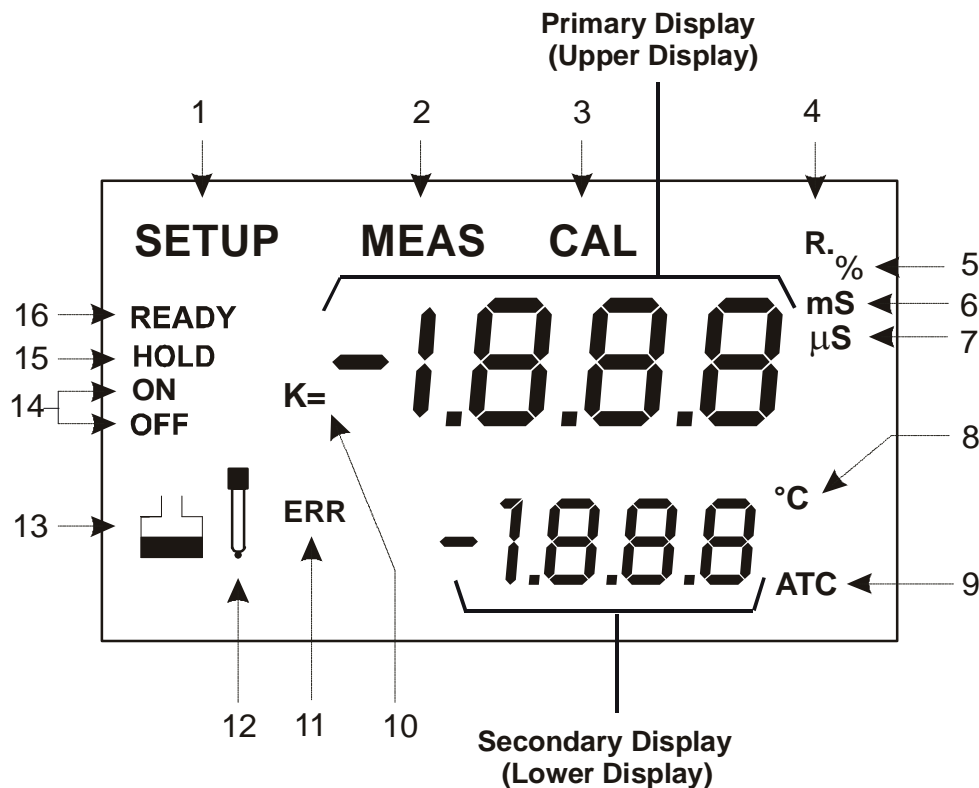

1. <b>SETUP</b> - Setup mode indicator	5. % - Temperature Coefficient indicator	9. <b>ATC</b> - Automatic Temp. Compensation	13.  - Calibration standard indicator
2. <b>MEAS</b> - Measurement mode indicator	6. <b>mS</b> - Milli Siemens indicator	10. <b>K =</b> - Cell Constant indicator.	14. <b>ON /OFF</b> - READY set up enable/disable indicator.
3. <b>CAL</b> - Calibration mode indicator	7. <b>μS</b> - Micro Siemens indicator	11. <b>ERR</b> - Wrong key press error indicator	15. <b>HOLD</b> - Hold indicator
4. <b>R.</b> - Line Resistance in Ohms	8. <b>°C</b> - Temperature indicator	12.  - Electrode indicator	16. <b>READY</b> - Ready indicator

## 4.2 Keypad

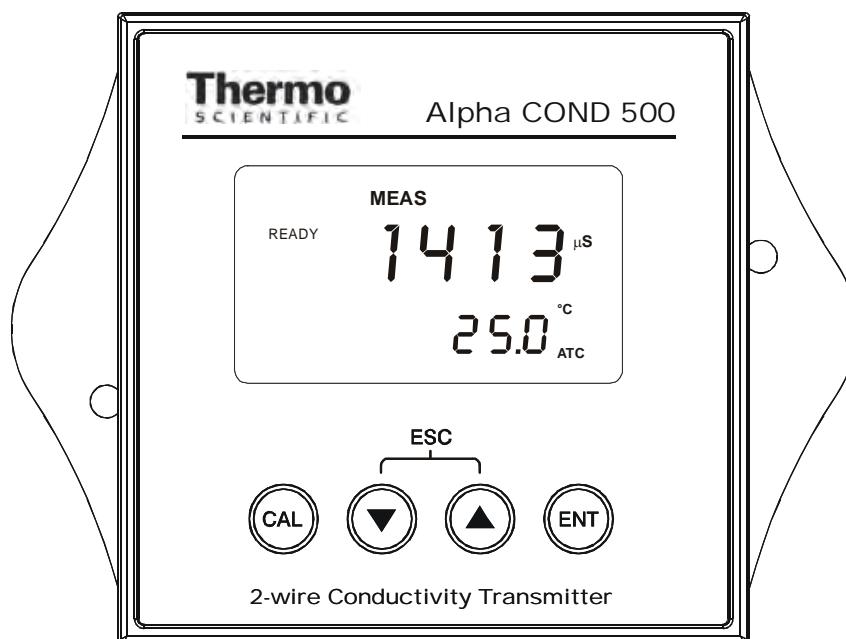

The four-button keypad allows easy and quick operations of the Transmitter.

Key	Function
CAL	Brings you directly into the Calibration mode. If you were in Conductivity Measurement mode, press CAL to enter Conductivity Calibration mode.
▲ / ▼	To scroll through the various submenus To increment/decrement values or toggle between options (in the SETUP/CAL modes) When pressed together, serves as escape function to return to MEAS mode from any point (CAL or SETUP modes).
ENT	To confirm your calibration values in Calibration mode. To confirm selections in SETUP mode. While in MEAS mode, pressing ENT takes you directly to SETUP submenu

NOTE: Error indicator 'ERR' will be displayed if an invalid key is pressed during a particular operation.

---

---

## 5 CALIBRATION

---

---

### 5.1 Important Information on Transmitter Calibration

Calibration should be carried when you are using your transmitter with a new electrode for the first time or when you suspect that the transmitter/electrode is out of calibration. Your transmitter allows you to perform temperature calibration and conductivity calibration.

As temperature readings affect the accuracy of conductivity measurements, it is recommended that temperature calibration should be carried out only if the temperature value displayed on the transmitter is different from that of a calibrated thermometer. A temperature offset calibration of  $\pm 5$  °C from the default reading is allowed. Once a temperature calibration is performed, conductivity calibration should be carried out to ensure the accuracy of conductivity measurements are maintained.

Your transmitter has up to six selectable conductivity measuring ranges. The selection for the sixth range, range 6 (0.00 to 199.9 mS/cm), only appears in the Setup mode if the cell constant is selected to be  $K = 1.0$  or  $K = 10$  whereas range 1 (0.00 to 19.99  $\mu$ S/cm), will only appear when cell constant is selected to be  $K = 0.1$  or  $K = 1.0$ . Other wise, the selection will be limited to five ranges only.

You can only calibrate one point in the measuring range that you have selected for your process application. You have to recalibrate your transmitter every time you change the measuring range since the calibration data of your transmitter will be erased every time a new measuring range is selected.

During conductivity calibration, the transmitter allows a calibration window of  $\pm 40\%$  from the measured default reading of the calibration standard. The minimum allowable calibration point is 10% of the full scale reading of the range selected.

For best results, select a standard value close to the sample value you are measuring. Alternatively use a calibration solution value that is approximately  $2/3$  the full-scale value of the measurement range you plan to use. The following table 1 lists the corresponding conductivity ranges. You should calibrate, in the range that you have selected, using a solution that falls between the values in the “recommended calibration solution range” column.

Table 1

Conductivity Measuring Range	Recommended Calibration Solution Range
0.00 → 19.99 $\mu$ S	6.00 to 17.00 $\mu$ S
0.0 → 199.9 $\mu$ S	60.0 to 170.0 $\mu$ S
0 → 1999 $\mu$ S	600 to 1700 $\mu$ S
0.00 → 10.00 mS	6.00 to 7.00 mS
0.00 → 19.99 mS	6.00 to 17.00 mS
0.0 → 199.9 mS	60.0 to 170.0 mS

To view current calibration point, see Section 6.8 - Viewing Calibration .

Do not reuse calibration solutions after calibration. Contaminants in the solution can affect the calibration, and eventually the accuracy of the measurements. Use fresh calibration solution each time you calibrate your meter.

**NOTE:** Your transmitter is factory set to a temperature coefficient of 2.1% per °C. For most applications this will provide good results. The factory default value for normalization temperature is 25 °C. If you need to set a different temperature coefficient or change the normalization temperature value, see Section 6.5 - Temperature Coefficient and Normalization Temperature Setting for further information.

**NOTE:** In the CAL mode, the 4/20 mA output current will be automatically held. 'HOLD' will be displayed on LCD. After calibration is performed and when the transmitter is back to the measurement mode, the 'HOLD' is automatically released. Please refer to section 6.3 for more details.

## 5.2 Temperature Calibration

You need to perform temperature calibration if your transmitter temperature reading is inaccurate or if the transmitter's cell constant setting is changed. It is because the transmitter's temperature offset calibration will be erased once a new cell constant is selected.

It is important to ensure that temperature calibration is carried out first prior to conductivity calibration since temperature readings affect the accuracy of conductivity measurements. Your transmitter allows a one point temperature calibration using reference of a thermometer known to be accurate. Please refer to Section 6.2 - Temperature Compensation Setting for temperature calibration procedure.

### 5.3 Conductivity Calibration

A 1-point Calibration is required for this transmitter. If the calibration process is aborted, your transmitter will revert to the previous calibration data.

1. Organize your calibration standard solution in two beakers – one for rinsing and the other for calibration. Prepare separate de-ionized water for electrode rinsing.
2. Rinse the electrode in de-ionized water and then rinse with the calibration standard.
3. Dip the electrode to the calibration standard intended for calibration and swirl gently to create a homogenous sample. Wait for the reading to stabilize.
4. Press the CAL key to enter calibration mode. The upper display will show the measured reading based on the last calibration setting whereas the lower display will show the measured default reading of the standard.
5. Use the ▲ or ▼ keys to adjust the upper display to the calibration standard value.

**Note:** You can offset the conductivity reading within  $\pm 40\%$  from the default reading of the standard. The minimum allowable calibration point is 10% of the full scale reading of the range selected.

6. Press the ENTER key to confirm the calibration value and to return to the measurement mode.

**Note:** To exit this program without confirming the calibration, press the ▲ and ▼ keys together (Escape).

**Note:** When there is a calibration error, the buffer icon and ERR annunciator will appear together with a blinking electrode icon. Press both ▲ and ▼ keys together TWICE to return to the measurement mode.

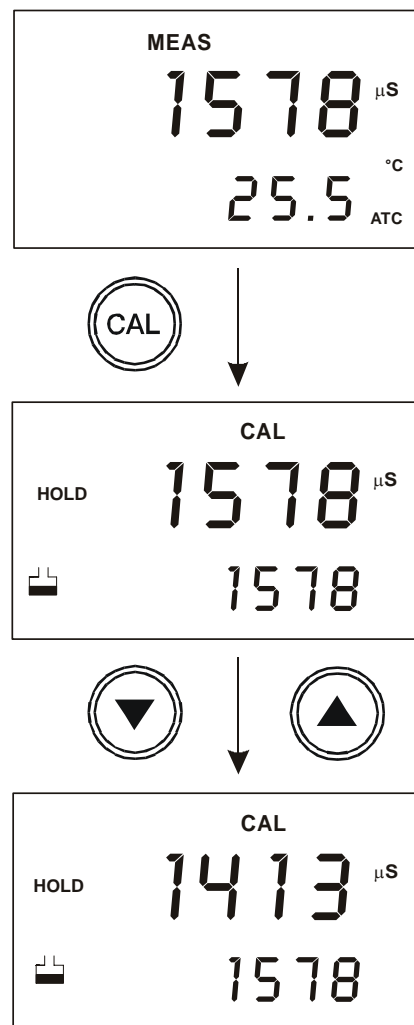

---

---

## 6 ADVANCED SETUP FUNCTIONS

---

---

The advanced setup mode lets you customize your transmitter's preferences and defaults. This transmitter features different sub groups that organize all setup parameters. The sub-groups are:

### 6.1 Range and Zooming Selection Setting

Your COND 500 transmitter provides six selections of conductivity measurement ranges to suit your process application needs. Zooming selection is available where both the 4 mA and 20 mA output current can be assigned to specific conductivity values for a more refined output.

From the measurement mode,

1. Press the ENT key to enter the setup mode. Transmitter displays 'SEt rng' indicating the range setup mode.
2. Press the ENT key again. The display will show the last set conductivity measurement range.
3. Use the ▲ or ▼ keys to scroll through the six ranges and press the ENT key to select your desired range. The transmitter will now switch to the zooming selection and display the low zoom value setup.

NOTE: Range 6 selection page will only appear in the setup mode when the cell constant is selected as K = 1.0 or K = 10. Range 1 will only appear when cell constant is selected as K = 0.1 or K = 1.0

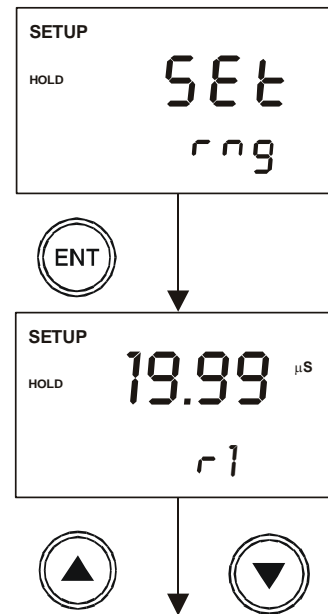

**Six Range selection**

4. For zooming setting, use the ▲ or ▼ keys to set the conductivity low zoom value for the 4 mA current and press the ENT key to confirm. The transmitter now displays the high zoom value setup.
5. Use the ▲ or ▼ keys again to set the conductivity high zoom value for the 20 mA current and press the ENT key to confirm and return to the range setup mode.
6. Press both ▲ and ▼ keys together to return to the measurement mode.

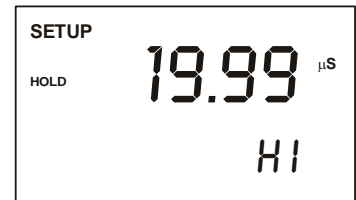
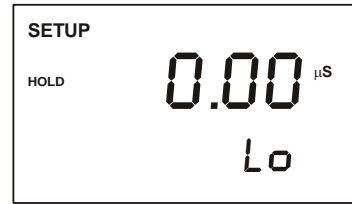

## 6.2 Temperature Compensation Setting

Conductivity readings are affected by temperature. Under varying temperature conditions, use ATC to compensate for the conductivity values. If temperature of sample is constant, and a temperature sensor/probe is not available, Manual Temperature Compensation can be utilized.

### 6.2.1 Automatic Temperature Compensation

For automatic temperature compensation (ATC) selection, connect the ATC sensor to the transmitter, as described in Section 2.2.2.

1. Press the ENT key to enter the setup mode. Use the ▲ or ▼ keys to scroll through the sub-menus till LCD displays '**SEt °C**'.
2. Press the ENT key to enter the temperature compensation mode. Display shows '**AtC On**' or '**AtC Off**'. Use ▲ or ▼ keys to select '**AtC On**' and then press the ENT key.
3. Dip ATC sensor into a solution of known temperature (i.e. a temperature bath). Allow time for temperature sensor to acclimatize with surrounding bath temperature.
4. Use ▲ or ▼ keys to adjust the displayed reading to the correct temperature value according to the temperature bath. Maximum adjustments allowed is  $\pm 5\text{ }^{\circ}\text{C}$  ( $\pm 9\text{ }^{\circ}\text{F}$ ) from the default reading.
5. Once you have adjusted to the correct temperature value, press the ENT key to confirm the setting.
6. Press ▲ and ▼ keys together to return to the measurement mode.

The ATC indicator will light up on the LCD.

NOTE: If you are using a temperature sensor, the sensor must be submersed in the liquid you are measuring.

### 6.2.2 Manual Temperature Compensation

For manual temperature compensation you can set the process and calibration temperatures. This allows calibration at a temperature other than the process temperature. Example: setting a calibration temperature of 25°C lets you calibrate using standard solutions at 25°C, even if your process temperature is different from 25°C.

From the measurement mode,

1. Press the ENT key and use ▲ or ▼ keys to select '**SEt °C**'.
2. Press the ENT key to enter the temperature compensation mode. Display shows '**AtC On**' or '**AtC Off**'. Use ▲ or ▼ keys to select '**AtC Off**' and then press the ENT key.
3. The primary display will show temperature (default is 25.0), and the secondary display shows 'P °C'. This is the page for setting the temperature of your process or sample by using an accurate thermometer as reference.
4. Use ▲ or ▼ keys to set the transmitter to the temperature of your process or sample. Press the ENT key.
5. The primary display shows temperature (default is 25.0), and secondary display shows 'C °C'. This is the page for setting the temperature of your calibration solutions.
6. Use ▲ or ▼ keys to set the transmitter to the temperature of your calibration solutions. Press the ENT key.
7. Press ▲ and ▼ keys together, to return to the measurement mode.

The transmitter will now compensate conductivity readings for the manually set temperature (values taken from P °C).

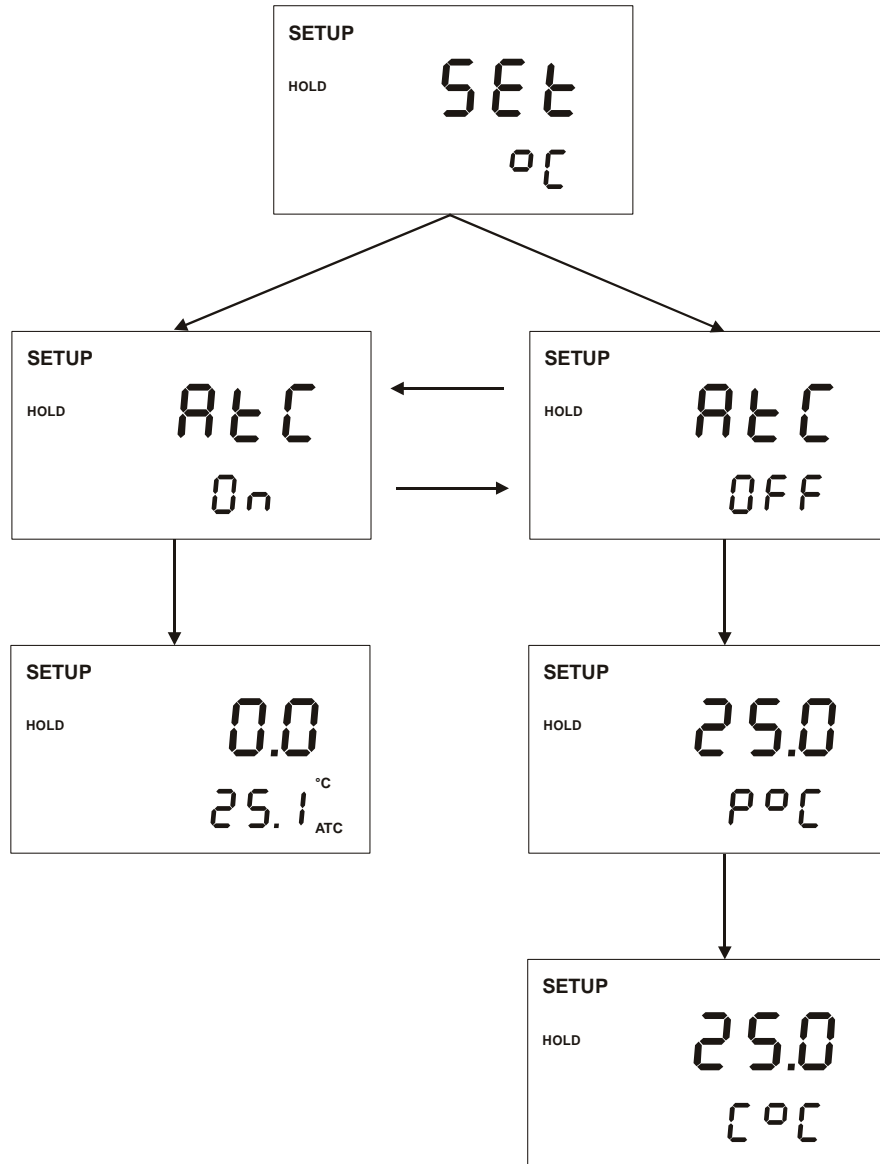

**Temperature Compensation Setting Chart – Alpha COND 500 Transmitter**

### 6.3 HOLD Current Setting

When Transmitter is in CAL or SETUP modes, it automatically goes into a 'HOLD' mode.

To indicate Transmitter is in 'HOLD' mode, output current can be set to 22 mA output by activating the 'HLD On'.

1. Press the ENT key and use ▲ or ▼ keys to scroll till LCD displays 'SEt' in the upper display; and 'HLd' in the lower display. Press the ENT key again.
2. Upper display now shows 'HLd'. Lower display will show either 'OFF' or 'On'. Use ▲ or ▼ keys to toggle between 'On' or 'OFF'. Press ENT to accept selection.
3. Press ▲ and ▼ keys together, to return to the measurement mode.

NOTE: If 'HLd' is set to 'OFF', then current output will be equivalent to last measured value.

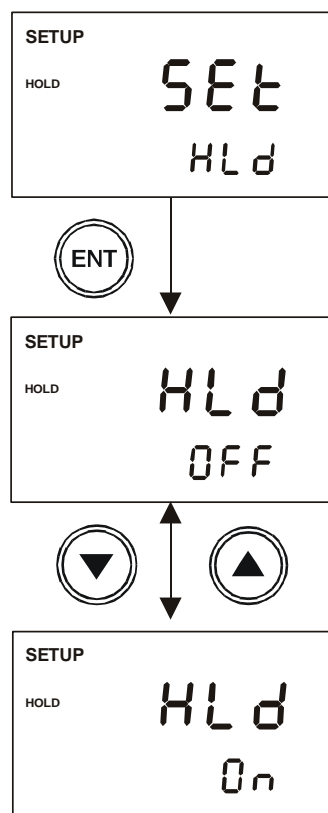

### 6.4 Out-of-Range Current Setting

The transmitter can be set to give a fix current output of 3.8 mA when the conductivity readings exceed the zoom setting range. This Out of Range indicator feature is applicable in the uS ranges only.

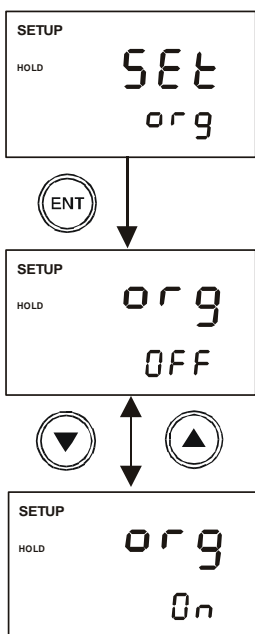

1. Press the ENT key and use ▲ or ▼ keys to scroll till LCD displays 'SEt' in the upper display; and 'org' in the lower display.
2. Press the ENT key again. Upper display now shows 'org'. Lower display will show either 'OFF' or 'On'. Use ▲ or ▼ keys to toggle between 'On' or 'OFF'. Press the ENT key to confirm the selection.
3. Press ▲ and ▼ keys together, to return to the measurement mode.

NOTE: If 'org' is set to 'OFF', current output below the low zoom setting will be at 4 mA, while current output above the high zoom setting will be at 20 mA.

## 6.5 Temperature Coefficient and Normalization Temperature Setting

Since different process liquid may require different temperature coefficient factor for its temperature compensation calculation, COND 500 transmitter allows 0 to 10% temperature coefficient factor adjustment to cater for your different application needs. You also have the selection of 25.0 °C or 20.0°C for the conductivity measurement normalization temperature.

### 6.5.1 Setting the temperature coefficient

From the measurement mode,

1. Press the ENT key to enter the setup mode. Use the ▲ or ▼ keys to scroll till LCD displays 'SET' in the upper display; and 'tPr' in the lower display.
2. Press the ENT key to view the temperature coefficient setup page, 'tC.O'.
3. Press the ENT key to enter the setup page and use the ▲ or ▼ keys to set the temperature coefficient value.
4. Press the ENT key to confirm your setting. The transmitter will now switch to the normalization setup page 'tn.r'

### 6.5.2 Setting the normalization temperature

From Step 4 above,

1. Press the ENT key to enter the normalization setup page.
2. Use the ▲ or ▼ keys to select the desired normalization temperature (25.0 °C or 20.0°C).

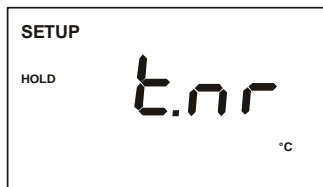

3. Press the ENT key to set the normalization temperature.
4. Press ▲ and ▼ keys together, to return to the measurement mode.

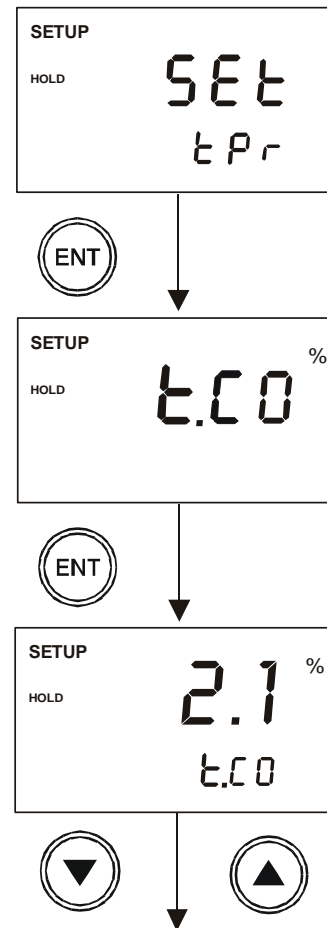

## 6.6 Cell Constant Setting

You can select up to three types of cell constant in the setup mode: - K=1.0, K=0.1 or K=10.

From the measurement mode,

1. Press the ENT key to enter the setup mode. Use the ▲ or ▼ keys to scroll till LCD displays 'SEt' in the upper display; and 'CEL' in the lower display.
2. Press the ENT key to enter the cell constant setup page.
3. Use the ▲ or ▼ keys to select the desired cell constant and press the ENT key to confirm the selection.
4. Press ▲ and ▼ keys together, to return to the measurement mode.

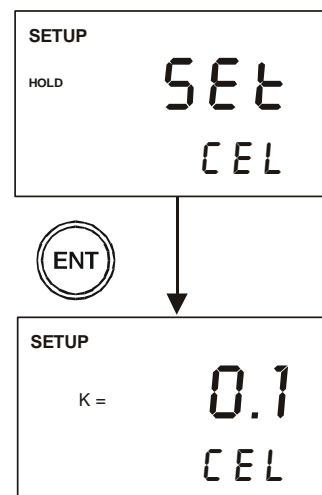

## 6.7 Line resistance Setting

Line resistance of an electrode cable constitutes to error in measurement of high conductivity values as in range 6. This error can be compensated by inputting the electrode cable line resistance value in the setup mode.

From Range 6 measurement mode,

1. Press the ENT key to enter the setup mode. Use the ▲ or ▼ keys to scroll till LCD displays 'SEt' in the upper display; and 'Lnr' in the lower display.
2. Press the ENT key to enter the line resistance setup page.
3. Use the ▲ or ▼ keys to set the line resistance value (0 to 50 ohms) and press the ENT key to confirm the setting.
4. Press ▲ and ▼ keys together, to return to the measurement mode.

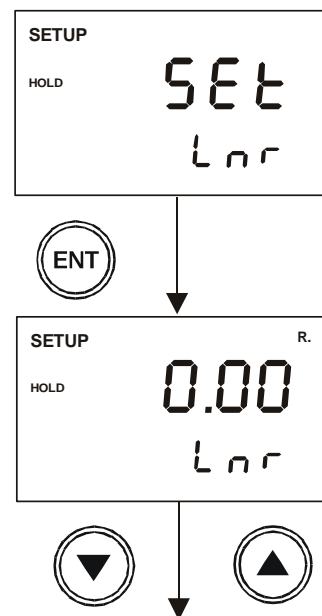

NOTE: The line resistance setup mode can be accessed only from range 6 measurement mode.

## 6.8 Viewing Calibration Point

This mode lets you view the current calibration point and its range.

From the measurement mode of a selected measuring range,

1. Press the ENT key to enter the setup mode. Use the ▲ or ▼ keys to scroll till LCD displays 'CAL' in the upper display.
2. Press the ENT key to enter the calibration point viewing page. The display will show the current calibration point and its range.
3. Press ▲ and ▼ keys together, to return to the measurement mode.

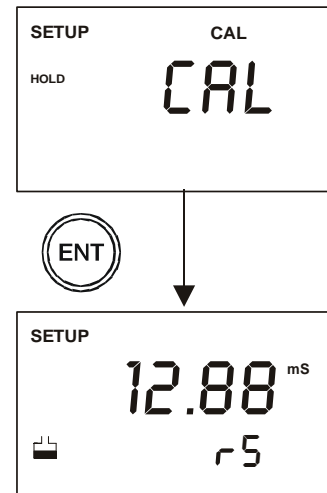

NOTE: This setup mode will only show the calibration point for the selected measuring range. If there is no calibration done in the selected range, the display will show '---'.

## 6.9 Viewing the Electrode Data

The COND 500 transmitter lets you check the electrode's parameters for diagnostic purposes. This option shows you the current effective cell constant and its range. The cell constant is adjusted according to your calibration.

From the measurement mode,

1. Press the ENT key to enter the setup mode. Use the ▲ or ▼ keys to scroll till LCD displays 'ELE' in the upper display.
2. Press the ENT key to enter the electrode data viewing page. The display will show the current effective cell constant and its range.
3. Press ▲ and ▼ keys together, to return to the measurement mode.

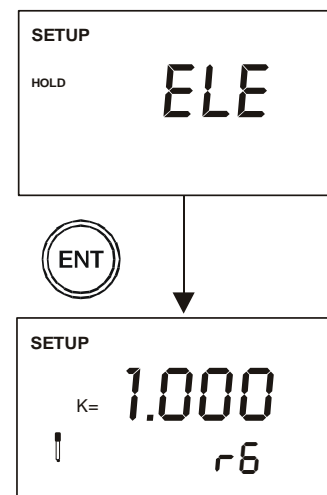

## 6.10 Reset Function

The reset function lets you choose to either reset the transmitter's conductivity calibration only or conductivity calibration plus all setup functions that you might have changed back to factory default settings. However, the temperature compensation setting, as in Section 6.2, will remain unchanged.

From the measurement mode,

1. Press the ENT key to enter the setup mode. Use the ▲ or ▼ keys to scroll till LCD displays 'rSt' in the upper display.
2. Press the ENT key to enter the reset page. Use the ▲ or ▼ keys to toggle between 'CAL' and 'FCT' for reset type selection.
  - CAL – reset conductivity calibration only
  - FCT – reset conductivity calibration and all setup functions back to factory default
3. Press the ENT key to confirm your selection. The lower display will blink momentarily before returning to the reset function setup mode.
4. Press ▲ and ▼ keys together, to return to the measurement mode.

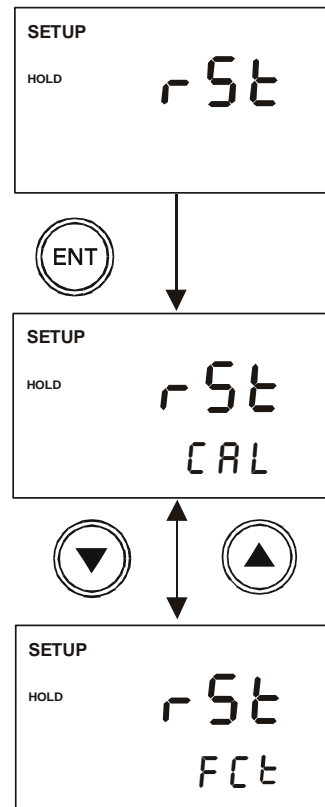

## 7 FACTORY DEFAULT SETTINGS

SETUP PAGE	FUNCTION	DEFAULT SETTING
SET rng	Selection of effective conductivity range Setting low zooming selection Setting high zooming selection	1999 uS, r3 0 uS, Lo 1999 uS, Hi
SET °C	Selection of Automatic or Manual Temperature Compensation	AtC On
SET HLd	Selection of HOLD current to be of 22 mA or the last current output value	HLd OFF
SET org	Selecting Out of Range current output to be constant 3.8 mA or 4mA for under range and 20 mA for over range	org OFF
SET tPr	Setting Temperature Coefficient Setting Normalization Temperature	2.1% 25.0 °C
SET CEL	Selecting the various cell constant	K = 1.0
SET Lnr	Setting the line resistance value	0.00
CAL	Viewing current calibration point	--- ; r3
ELE	Viewing electrode's current cell constant	K = 1.000; r3
rSt	Selection of calibration reset or factory default reset	rSt CAL; rSt FCt

## 8 TROUBLE SHOOTING GUIDE

Problem	Cause	Solution
Power on but no display	a). Loose connections b). Cables not in correct polarity (+ and – position).	a). Ensure cables are making good contact. b). Re-wire loop cables with correct polarity.
Unstable conductivity readings	a). Air bubbles in probe. b). Dirty probe. c). Probe not deep enough in sample.	a). Tap probe to remove bubbles. b). Clean probe and recalibrate. c). Ensure that sample entirely covers the probe sensors.
Oscillating temperature readings	a). Electrical noise interference	a) Ensure shield wire is properly connected to pin 7
Slow response	a). Dirty / Oily probe.	a). Clean probe.
Blinking ATC	a) No temperature sensor connection during ATC mode	a) Ensure temperature sensing cable are making good contact
Blinking electrode indicator	a) Error in calibration	a) Ensure calibration standard solution is not contaminated. Ensure clean probe is used.
Or (Conductivity)	a) Conductivity measurement value is above the specified range	a) Ensure correct conductivity measurement range is selected.
Or / Ur (Temperature)	b) Temperature value exceeds above/ below the specified range.	b) Ensure temperature calibration is done properly. Ensure process temperature is within the specified range.

## 9 SPECIFICATIONS

Cell Constant (K)	Conductivity Range (r1 to r6)	Resolution
0.1, 1.0	Range 1 = 0 – 19.99 $\mu\text{S}/\text{cm}$	0.01 $\mu\text{S}$
0.1, 1.0, 10.0	Range 2 = 0 – 199.9 $\mu\text{S}/\text{cm}$	0.1 $\mu\text{S}$
0.1, 1.0, 10.0	Range 3 = 0 – 1999 $\mu\text{S}/\text{cm}$	1 $\mu\text{S}$
0.1, 1.0, 10.0	Range 4 = 0 – 10.00 $\text{mS}/\text{cm}$	0.01 $\text{mS}$
0.1, 1.0, 10.0	Range 5 = 0 – 19.99 $\text{mS}/\text{cm}$	0.01 $\text{mS}$
1.0, 10.0	Range 6 = 0 – 199.9 $\text{mS}/\text{cm}$	0.1 $\text{mS}$

Temperature Range	0-100 °C
Temperature Resolution	0.1 °C
Temperature Relative Accuracy	$\pm 0.5$ °C
Temperature Compensation	Auto (Pt 100) (from 0 to 100 °C) Manual (from 0 to 100 °C)
Temperature Coefficient Factor Setting	0 to 10%
Normalization Temperature Setting	25.0 °C or 20.0 °C
Number of calibration points	1
Output	4.0 to 20.0 mA (Galvanically Isolated)
Over- / Under range current output (Only applicable in the $\mu\text{S}$ range)	'ON' Select - 3.8 mA 'OFF' Select - 4 mA (under-range) & 20 mA (over-range)
HOLD current output	'ON' Select - 22 mA 'OFF' Select - Last measured current value
Display	Custom Dual LCD
Averaging/Stability (READY indicator)	Yes
Operating Temperature	0 to 100 °C
Power Requirements	12 to 24 VDC
Load Resistance	Max. 600 $\Omega$
Dimension / Weight	96 x 96 x 66 mm / 210 g

## 10 ACCESSORIES

### Replacement Unit

Product Description	Thermo Scientific Code No.	Eutech Code Code No.
Alpha COND 500 2-Wire Conductivity Transmitter	TSCONCTP0500	ECCONCTP0500

### Assembly Accessories

Product Description	Order Code
Conductivity cell, Epoxy body, Graphite sensor, w/3-wire Pt100, k = 0.1	ECCONSEN89X
Conductivity cell, Epoxy body, Graphite sensor, w/3-wire Pt100, k = 1.0	ECCONSEN88X
Conductivity 2 Cell type probe, up to 20 $\mu$ S; Cell constant, K=0.01 with integrated Pt 100, Material SS316 and 25ft cable (open-ended)	EC-CS10-0-01S
Conductivity 2 Cell type probe, up to 20 $\mu$ S; Cell constant, K=0.01 with integrated Pt 100, Material Titanium and 25ft cable (open-ended)	EC-CS10-0-01T
Conductivity 2 Cell type probe, 0.1 - 200 $\mu$ S; Cell constant, K=0.1 with integrated Pt 100, Material SS316 and 25ft cable (open-ended)	EC-CS10-0-1S
Conductivity 2 Cell type probe, up to 200 mS; Cell constant, K=1.0 with integrated Pt 100, Material SS316 and 25ft cable (open-ended)	EC-CS10-1-0S

NOTE: Please contact your authorised distributor or dealer for the prices of extension measuring cables and other accessories like tee joints, electrode assembly, and calibration solutions.

---

---

## 11 WARRANTY

---

---

This transmitter is supplied with a one-year warranty against significant deviations in material and workmanship from date of purchase and a six-month warranty for probe. Each instrument will have a warranty card with a specific serial number. The warranty card must be endorsed by the Authorized Distributor at the point of sale.

If repair or adjustment is necessary and has not been the result of abuse or misuse within the designated period, please return – freight pre-paid – and correction will be made without charge. Thermo Scientific will determine if the product problem is due to deviations or customer misuse.

Out of warranty products will be repaired on a charged basis.

### **Exclusions**

The warranty on your instrument shall not apply to defects resulting from:

- Improper or inadequate maintenance by customer
- Unauthorized modification or misuse
- Operation outside of the environment specifications of the products

---

---

## 12 RETURN OF ITEMS

---

---

Authorization must be obtained from our Customer Service Department or authorized distributor before returning items for any reason. A “Return Goods Authorization” (RGA) form is available through our authorized distributor. Please include data regarding the reason the items are to be returned. For your protection, items must be carefully packed to prevent damage in shipment and insured against possible damage or loss. Thermo Scientific will not be responsible for damage resulting from careless or insufficient packing. A restocking charge will be made on all unauthorized returns.

NOTE: Thermo Scientific reserves the right to make improvements in design, construction, and appearance of products without notice.