

SAVE THESE INSTRUCTIONS



TM Series Electronic Water Meters



User Manual

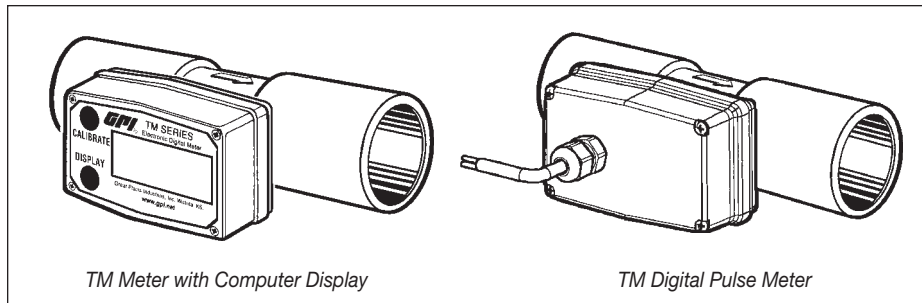

TABLE OF CONTENTS

English	1
Español.....	8
Deutsch	15
Italiano	22
Français.....	29

ENGLISH

IMPORTANT NOTICE

Use TM Series meters with water and other chemicals compatible with wetted components. Do not use to meter fuel or incompatible chemicals. TM Series meters are available with either a computer for local electronic display, or a conditioned signal output module to provide a digital signal to customer interfacing equipment. TM Series meters with computer display measure in gallons or litres. Refer to the Calibration Section for details.

These meters are not legal for trade applications.

TM Series meters are very sensitive to electric noise if operated within 1 to 2 inches of some electric motors or other sources of electronic noise.

INSTALLATION

Connections

Install your meter in-line either horizontally or vertically or at the end of the hose adjacent to the nozzle. Installation to metal connections is not recommended. Install as follows:

1. Plan to install turbine with a minimum straight pipe length as follows:
 - Upstream from the turbine, allow a minimum straight pipe length of 10 times the internal diameter of the turbine.
 - Downstream from the turbine, allow a minimum straight pipe length of 5 times the internal diameter of the turbine.
2. For Spigot (Pipe) End use only primer and solvents approved for PVC gluing.

For NPT and BSP Fittings wrap all connections with 3 to 4 wraps of thread tape (optional to use pipe thread sealant). Make sure the tape does not intrude into the flow path.

3. Attach meter with arrow pointed in the direction of fluid flow.
4. For NPT and BSP Fittings - Hand tighten the meter at the housing ends. Do not use a wrench or similar tool to tighten. This can damage the housing.

⚠ WARNING

Compatibility of this product's material and the process fluid and/or environment should be considered prior to putting into service.

⚠ WARNING

Product should never be operated outside its published specifications for temperature or pressure. See specifications for your model.

⚠ WARNING

Make sure flow and pressure have been eliminated from process pipe prior to installing or removing product.

⚠ WARNING

Always use appropriate thread sealant or flange gaskets when connecting product to process piping.

⚠ CAUTION

To protect against leakage, seal all pipe threads with an appropriate sealing compound. Make sure the sealing compound does not intrude into the flow path.

NOTE: If connecting to new male pipe threads, burrs and curls can adversely affect accuracy. Correct the problem prior to turbine installation.

NOTE: Do not over tighten the flange bolts. This may cause the gasket to be compressed into the flow stream and may decrease the accuracy of the meter.

⚠ CAUTION

Installation near high electromagnetic fields and high current fields is not recommended and may result in inaccurate readings.

Wiring Diagram 1

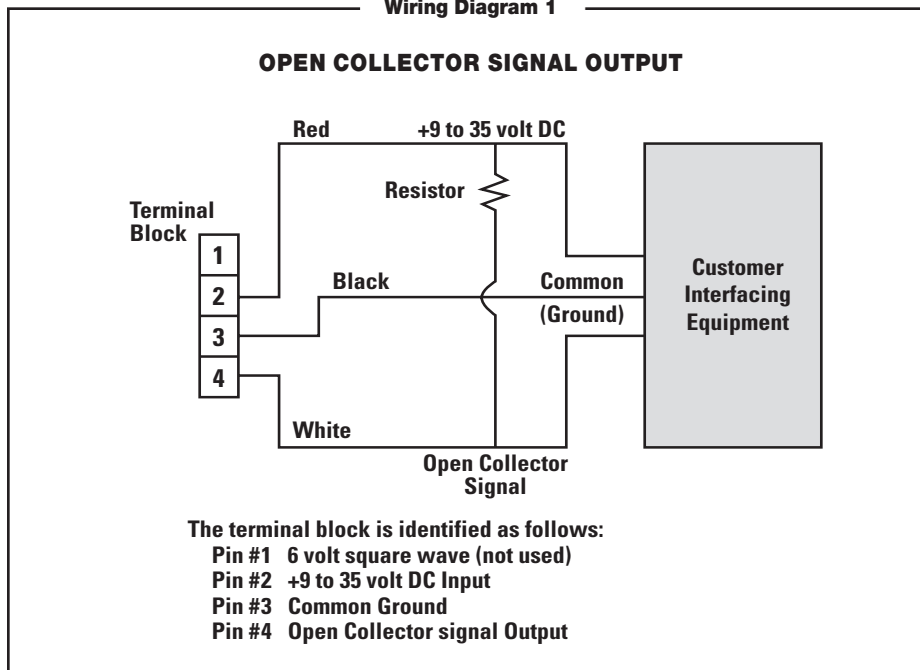

Wiring Diagram 2

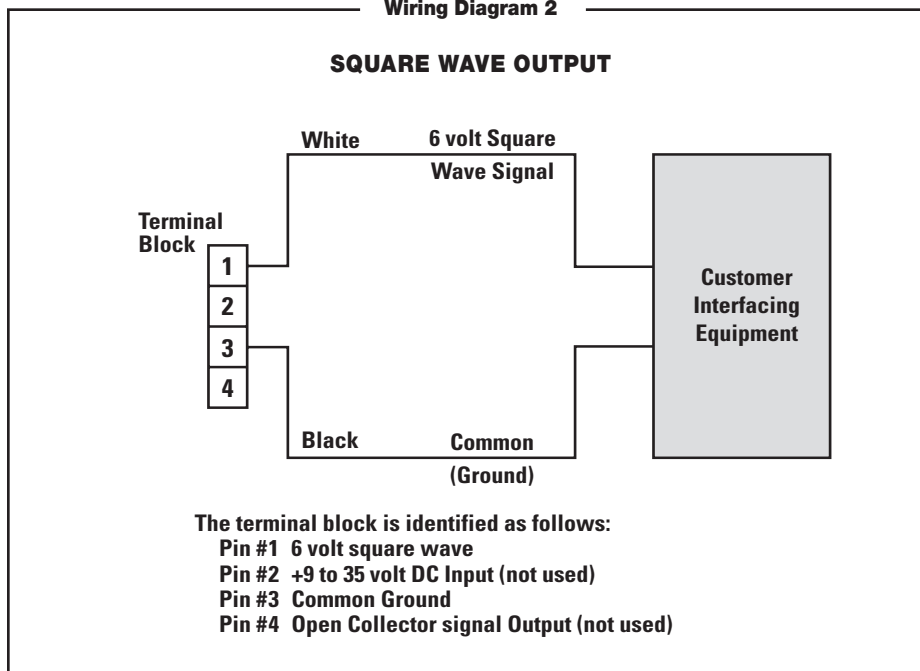

Conditioned Signal Output Module Wiring

This conditioned signal output module can be wired to provide an open collector signal output or 6-volt square wave output.

Open Collector Signal Output

To achieve an open collector signal output, reference Wiring Diagram 1. The terminal block is located on the back side of the module. The module is factory assembled for open collector signal output. Please provide the (820 ohm minimum) resistor.

Ten feet (3 m) of cable is provided with the module. Trim it to desired length or extend it as necessary. Distances up to 5,000 feet (1,524 m) can be achieved for open collector signal output.

Square Wave Output

To achieve square wave output, reference Wiring Diagram 2 and use an Electronic Digital Meter Battery Kit (sold separately) for battery power. The terminal block and battery location are located on the back side of the module. Access as follows:

1. Remove the four Phillips-head screws from the front of the module and lift the module from the turbine.
2. To change terminal block connections, loosen the appropriate screws. Reconnect the wires in the proper positions and tighten the screws.
3. Install the batteries. Make sure the positive post is in the correct position.
4. Position the module on the turbine housing. To avoid moisture damage, make sure the seal is fully seated. Tighten the four screws on the front of the module.

Ten feet (3 m) of cable is provided with the module. Trim the cable to desired length or extend it as necessary.

Verify Meter Accuracy

Before using, check the meter's accuracy and verify calibration.

1. Make sure there is no air in the system by starting the flow until it runs steadily. Then, stop or divert the flow using a valve or nozzle.

- Meter an exact known volume into an accurate container. For best results, meter with one continuous full stream.
- Check the volume against the display or recording equipment. If the amount metered is accurate, further calibration is not necessary. If not, refer to the Calibration Section for further instructions.

OPERATION

Computer Display – Batch and Cumulative Totals

The computer maintains two totals. The Cumulative Total provides continuous measurement and cannot be manually reset. The Batch Total can be reset to measure flow during a single use. The Cumulative Total is labeled TOTAL 1, Batch Total is labeled TOTAL 2 BATCH.

When the Cumulative Total reaches a display reading of 999,999 the computer will highlight an X10 icon. This indicates to the operator that a zero must be added to the 6 digits shown. When the next rollover occurs, the computer will highlight an X100 icon. This indicates to the operator that two zeros must be added to the 6 digits shown.

Press the DISPLAY button briefly to switch between the TOTAL 1, TOTAL 2 BATCH and FLOWRATE. Press DISPLAY briefly to display the TOTAL 2 BATCH. Hold the DISPLAY button for 3 seconds to reset the Batch Total to zero.

When fluid is flowing through the meter, a small propeller icon is highlighted.

NOTE: Totalization counts total units without differentiating between gallons, litres or field calibrated units.

Flowrate Feature

To use this feature, press and release DISPLAY button until FLOWRATE icon appears. The factory set time base will be highlighted to the right of FLOWRATE (M = minutes, H = hours, D = days). When FLOWRATE is invoked, the display will be indicating rate of flow.

Activate the Meter

Computer is on continuously and always ready to perform. The computer is powered by field replaceable batteries. When display becomes

dim, faded or the low battery message appears (see below), the batteries need to be replaced. Reference the Maintenance Section for details.

LobAtt

Factory and Field Calibration

All calibration information is visible to the user as icons on the top line of the display, above the numeric digits.

All units are configured with a “factory” calibration. Both gallons and litres are available (“GL” or “LT” will be displayed). While holding the CALIBRATE button, briefly press DISPLAY to toggle between gallons and litres. This factory calibration (indicated with FAC) is permanently programmed into the computer and is not user adjustable.

NOTE: Your computer may have other units of measure programmed into it. If so, holding the CALIBRATE button and momentarily pressing the DISPLAY button will toggle through all factory set units. Other possible units are: IGL (imperial gallon), QT (quart), CF (cubic feet), CM (cubic meter), BL (42 gal. barrel), CC (cubic centimeter) or OZ (ounce).

Switching between different units will not corrupt the Total’s contents. For example, in GL mode, the computer totalizes 10.00 gallons, if the user switches to LT mode, the display will read 37.85 litres (the same volume, different unit).

The “field” calibration may be set by the user, and can be changed or modified at any time using the calibration procedure described in the Calibration Section. Totals or flowrate derived from the field calibration are invoked when the FAC icon is no longer visible on the top line of the display.

CALIBRATION

Verify Accuracy Before Beginning Field Calibration

For the most accurate results, dispense at a flowrate which best simulates your actual operating conditions. Avoid “dribbling” more fluid or repeatedly starting and stopping the flow. This can result in less accurate calibrations.

Make sure you meet the meter’s minimum flowrate requirements:

TM Series Meters

1/2 inch meter	1 GPM (3.8 LPM)
3/4 inch meter	2 GPM (7.5 LPM)
1 inch meter	5 GPM (18.8 LPM)
1 1/2 inch meter	10 GPM (37.5 LPM)
2 inch meter	20 GPM (75 LPM)

The use of a uniformly dependable, accurate calibration container is recommended for the most accurate results. Due to high flowrate, it is strongly recommended that calibration be completed with a combination of volume and weight using fine resolution scales.

For best results, the meter should be installed and purged of air before field calibration.

Field Calibration with Computer Display

Field Calibration and Factory Calibration are defined in the Operation Section. Factory calibration settings are programmed into each computer during manufacturing, using water at 70° F (21° C). Readings using the Factory Calibration (FAC) may not be accurate in some situations, for example, under extreme temperature conditions, non-standard plumbing configurations or with fluids other than water.

Field Calibration Procedures (Correction Factor Method)

1. To calibrate, press and hold the CALIBRATE and DISPLAY buttons for about 3 seconds until you see FLdCAL. Release both buttons and you will see CF - 00.0. You are now in the field calibration mode and values from -99.9% to +99.9% can be entered.
2. The +/- position appears either as an “underscore” character for plus, or as a “hyphen” character for minus. The DISPLAY button selects the position and the CALIBRATE button toggles this character.
3. The DISPLAY button can then be pushed to select the numeric positions. Press the CALIBRATE button to scroll from 0 to 9. Enter the percentage of change you want the display to correct. When satisfied with the value, press both CALIBRATE and DISPLAY buttons simultaneously. CAEnd will be displayed and unit will go back to normal operation, less the FAC (factory calibration) icon.

4. All enabled units-of-measure remain visible and selectable – the entered correction will be applied to all enabled units.
5. To return to factory calibration (FAC), press and hold both CALIBRATE and DISPLAY buttons for about 3 seconds until FACCAL is displayed. Then release buttons. Unit should return to normal operation and FAC icon is visible.

Calibration with Conditioned Signal Output Module

The K-factor of your meter appears on the calibration report as the number of pulses per gallon. The factor is determined during production using water at 70° F (21° C). This K-factor may be used for “single point” calibration and provide acceptable accuracy. However, readings may not be accurate when using this calibration method in some situations. For example, extreme temperature conditions, non-standard plumbing configurations or with fluids other than water.

MAINTENANCE

Proper handling and care will extend the life and service of the meter.

Turbine Rotor

The meter is virtually maintenance-free. However, it is important the rotor moves freely. Keep the meter clean and free of contaminants.

If the rotor does not turn freely, apply a penetrating lubricant on the rotor, shaft and bearings. Remove any debris or deposits from the rotor using a soft brush or small probe. Be careful not to damage the turbine rotor or supports.

CAUTION

Blowing compressed air through the turbine assembly could damage the rotor.

CAUTION

Do not allow liquids to dry inside the turbine.

CAUTION

Handle the rotor carefully. Small scratches or nicks can affect accuracy.

Battery Replacement

The computer display is powered by two 3-volt lithium batteries which may be replaced while the meter is installed. When batteries are removed or lose power, the batch and cumulative totals and the field and factory calibrations are retained.

⚠ WARNING

(Battery) – Avoid mechanical or electrical abuse. Batteries may explode or cause burns, if disassembled, crushed or exposed to fire or temperatures in excess of 212°F (100°C). Do not short circuit or install with incorrect polarity. DO NOT INCINERATE.

⚠ CAUTION

Batteries should ONLY be replaced with P/N 113520-1 Kit (Includes two each P/N 902004-2 Batteries). Do not mix old with new. Do not use other brands or technologies.

Open battery cells should be disposed of in accordance with local regulations. Lithium batteries are best disposed of as a non-hazardous waste when fully or mostly discharged. EPA does not list or exempt Lithium as a hazardous waste. If waste lithium batteries are still fully charged or only partially discharged, they can be considered a reactive hazardous waste because of unconsumed lithium remaining in the battery. Such batteries may qualify as “Universal Waste” in many jurisdictions within the U.S. and thus can be shipped for disposal or recycling in accordance with Universal Waste requirements.

If the display becomes dim, blank or the low battery message appears (see below), replace the batteries as follows:



1. Remove the four Phillips-head screws from the face of the meter and lift the faceplate from the turbine.
2. Remove the old batteries and clean any corrosion from the terminals.
3. Install new batteries. Make sure the positive post is in the correct position.

4. When the batteries are replaced, the faceplate will power ON. Check the display to ensure normal functions have resumed before assembling again.
5. Reseat batteries, if necessary, and position the faceplate on the turbine housing. To avoid moisture damage, make sure the seal is fully seated. Tighten the four screws on the faceplate.

SPECIFICATIONS

Inlet and Outlet:

Spigot (Pipe) End Models:

TM050/TM050-P	½ inch Schd. 80, Spigot (Pipe)
TM075/TM075-P	¾ inch Schd. 80, Spigot (Pipe)
TM100/TM100-P	1 inch Schd. 80, Spigot (Pipe)
TM150/TM150-P	1 ½ inch Schd. 80, Spigot (Pipe)
TM200/TM200-P	2 inch Schd. 80, Spigot (Pipe)

NPT Models:

TM050-N/TM050-N-P	½ inch NPT
TM075-N/TM075-N-P	¾ inch NPT
TM100-N/TM100-N-P	1 inch NPT
TM150-N/TM150-N-P	1 ½ inch NPT
TM200-N/TM200-N-P	2 inch NPT

BSP Models:

TM100-B/TM100-B-P	1 in. BSP
TM150-B/TM150-B-P	1 ½ in. BSP
TM200-B/TM200-B-P	2 in. BSP

Design Type: Turbine

Wetted Components:

Housing: PVC
Journal Bearings: Ceramic
Shaft: Tungsten Carbide
Rotor and Supports: PVDF
Retaining Washer: Stainless Steel

Max. Working Pressure:

225 PSIG @ 73° F
BSP: 150 PSIG @ 73° F

U.S. Measurement

Unit of Measure: Gallon

Flow Range:

½ inch	1 - 10 GPM
¾ inch	2 - 20 GPM
1 inch	5 - 50 GPM
1 ½ inch	10 - 100 GPM
2 inch	20 - 200 GPM

Accuracy with Computer: ± 3.0% of reading (Accuracy can be improved with field calibration)

Operating Temperature: +32° to +140° F
(Do not allow fluid to freeze inside meter.)

Storage Temperature: -40° to +158° F

Product Weight:*

	Spigot (Pipe)	NPT	BSP
½ in.	.38 lbs.	.55 lbs.	N/A
¾ in.	.43 lbs.	.67 lbs.	N/A
1 in.	.49 lbs.	.84 lbs.	.84 lbs.
1 ½ in.	.66 lbs.	1.38 lbs.	1.47 lbs.
2 in.	.78 lbs.	1.78 lbs.	1.93 lbs.

Dimensions - Inches (W x H x L):**

	Without Fitting	With NPT Fitting
½"	2.1 x 2.5 x 4.3	2.1 x 2.7 x 6.0
¾"	2.1 x 2.7 x 4.4	2.1 x 2.9 x 6.1
1"	2.1 x 2.9 x 4.5	2.1 x 3.1 x 6.5
1 ½"	2.1 x 3.6 x 5.4	2.3 x 3.8 x 7.6
2"	2.4 x 4.1 x 5.5	3.5 x 4.4 x 7.9

	With BSP Fitting
½"	N/A
¾"	N/A
1"	2.1 x 3.1 x 6.7
1 ½"	2.2 x 3.7 x 7.6
2"	2.7 x 4.2 x 7.8

* Weight with computer display. Conditioned signal output module adds .30 lbs.

** Dimensions with computer display. Conditioned signal output module adds 1.1 inch to height.

Metric Measurement

Unit of Measure: Litre

Flow Range:

½ inch	3.8 - 38 LPM
¾ inch	7.6 - 76 LPM
1 inch	19 - 190 LPM
1 ½ inch	38 - 380 LPM
2 inch	76 - 760 LPM

Accuracy with Computer: ± 3.0% of reading (Accuracy can be improved with field calibration)

Operating Temperature: 0° to +60° C
(Do not allow fluid to freeze inside meter.)

Storage Temperature: -40° to +70° C

Product Weight:*

	Spigot (Pipe)	NPT	BSP
½ inch	.172 kg	.249 kg	N/A
¾ inch	.195 kg	.304 kg	N/A
1 inch	.222 kg	.381 kg	.381 kg
1 ½ inch	.299 kg	.626 kg	.666 kg
2 inch	.354 kg	.807 kg	.875 kg

Dimensions - cm (W x H x L):**

	Without Fitting	With NPT Fitting
½"	5.3 x 6.4 x 10.9	5.3 x 6.9 x 15.2
¾"	5.3 x 6.9 x 11.2	5.3 x 7.3 x 15.5
1"	5.3 x 7.4 x 10.9	5.3 x 7.9 x 16.5
1 ½"	5.3 x 9.1 x 13.7	5.8 x 9.7 x 19.3
2"	6.1 x 10.4 x 14.0	8.9 x 11.2 x 20.0

	With BSP Fitting
½"	N/A
¾"	N/A
1"	5.3 x 7.9 x 17.0
1 ½"	5.6 x 9.4 x 19.3
2"	6.9 x 10.7 x 19.8

* Weight with computer display. Conditioned signal output module adds .14 kg.

** Dimensions with computer display. Conditioned signal output module adds 2.8 cm to height.

PARTS

The following replacement parts and accessories are available for the TM Series meters:

Part No.	Description
113435-1	Conditioned Signal Output Module
113520-1	Battery Replacement Kit
116000-1	Calibration Container, Large (5 gallon)
125508-03	½ inch, Turbine Assy Kit
125508-04	½ inch NPT, PVC Turbine Assy Kit
125510-03	¾ inch, Turbine Assy Kit
125510-04	¾ inch NPT, PVC Turbine Assy Kit
125512-03	1 inch, Turbine Assy Kit
125512-04	1 inch NPT, PVC Turbine Assy Kit
125514-03	1 ½ inch, Turbine Assy Kit
125514-04	1 ½ inch NPT, PVC Turbine Assy Kit
125516-03	2 inch, Turbine Assy Kit
125516-04	2 inch NPT, PVC Turbine Assy Kit
901002-52	Seal
125512-05	1 inch BSP, PVC Turbine Assy Kit
125514-05	1 ½ inch BSP, PVC Turbine Assy Kit
125516-05	2 inch BSP, PVC Turbine Assy Kit

Computer Kits:

125509-03	½ inch, Computer Assy Kit
125511-03	¾ inch, Computer Assy Kit
125513-03	1 inch, Computer Assy Kit
125515-03	1 ½ inch, Computer Assy Kit
125517-03	2 inch, Computer Assy Kit

