

6" Temperature & Humidity Chart Recorder Manual

Table of Contents

- [Default Logger Settings](#)
- [Quick Start](#)
- [Display Symbols TH622/23](#)
- [On/Off](#)
- [Pen Home](#)
- [Alarm TH623/625](#)
- [Dip Switch Settings](#)
- [Recording Time](#)
- [Temperature Range](#)
- [Power](#)
- [LED Indicators](#)
- [Calibration](#)
- [Need to know](#)
- [Pen Adjust](#)
- [Troubleshooting](#)
- [Why isn't the chart keeping time or running slow?](#)
- [Why did the chart stop turning?](#)
- [Why don't the display and chart match?](#)
- [Why does the display read PROB?](#)
- [Why does calibration seem to be off?](#)
- [Why won't the battery back-up work?](#)
- [Why won't the chart recorder respond to changes?](#)
- [Why won't the unit power up?](#)
- [Warranty](#)
- [Factory Service & Returns](#)

This manual applies to : TH621/622/623/625

Default Logger Settings

- 7-day chart rotation
- 0 to 100°F (TH623/25)
- +32 to 100°F (TH621/22)

Quick Start

Your recorder has been preset to operate using the most popular settings:

Recording Time 7-day

Range TH621/22: +32 to +100°F TH623: 0 to +100°F

To change the range and recording time, please reference *Dip Switch Setup* in this manual.

1. Remove the protective pen caps. The blue pen has a longer pen arm and records humidity or dew point (depending on your dip switch

selection, see pg. 6). The red pen has a shorter arm and records temperature. The pens are offset to allow the red pen to glide under the blue pen. The blue pen indicates the correct time and the red pen precedes it

by 3/16 of an inch.

2. Insert 4 AA Batteries and plug in AC adapter. The unit will power on. (see Figure 3) The instrument will move pens to the appropriate readings.
3. Install the chart that matches the “Dip Switch settings” you have selected.
4. Press the **Pen Home** key to move the pens to the outside of the chart. The pens are automatically raised off the chart.
5. Remove the old chart. Place the new chart on the “Chart Hub” making certain that the edge of the chart slides under the “chart guide clips” located at the outside of the chart.
6. **Set the appropriate time.** There are two ways to adjust the chart and set the appropriate time:
 - a. Set the chart time manually by inserting a coin into the groove in the chart hub and turning clockwise until the correct hour (and day if applicable) on the chart is referenced to the timing arrow (just to the right of the pen tip on the dial). This feature should be used for fine adjustments only
 - b. To adjust the chart time, press and hold **Adjust-Up** and **Adjust-Down** buttons located on the back of the unit next to the dip switch (see Figure 3). The green LED will blink rapidly for about five seconds, then the LED will remain solid green. While in this state the **Adjust-Up** button will move the chart backward (counter clockwise) and the **Adjust-Down** button will move the chart forward (clockwise). Rotate the chart until the correct hour (and day if applicable) on the chart is referenced to the timing arrow. Once you have set your chart, press the **Pen Home** button to exit “Chart Adjust Mode”. The unit will take one minute to exit the “Chart Adjust Mode” once **Pen Home** is pressed. Press **Pen Home** to move the pens back onto the chart.
7. Place the TH6 recorder on a flat vibration-free surface. Be sure it is in a vertical position and level. For best performance and longevity, the location should be a clean environment, free from dust and corrosive fumes. Do not exceed temperature specifications.

Wall Mount Keyhole slots are provided on the TH6 recorder for wall mounting.

Display Symbols TH622/23

Figure 1

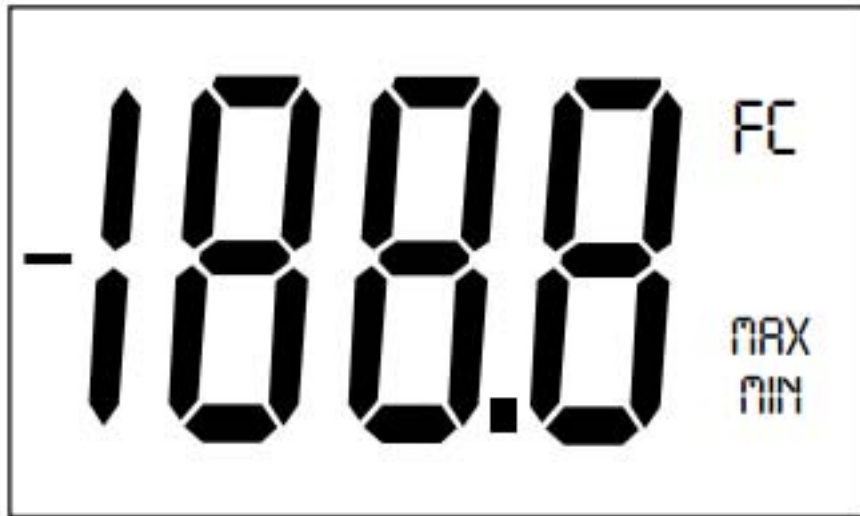

On/Off

The On/Off key turns the unit on and off.

Figure 2
TH623/25

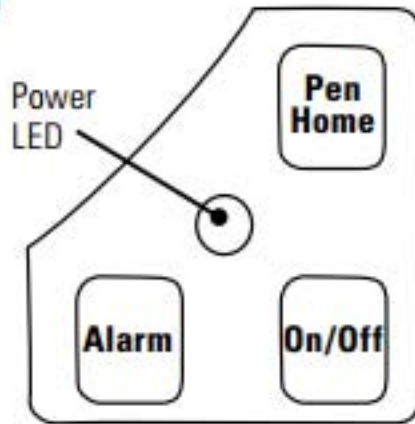

TH621/22

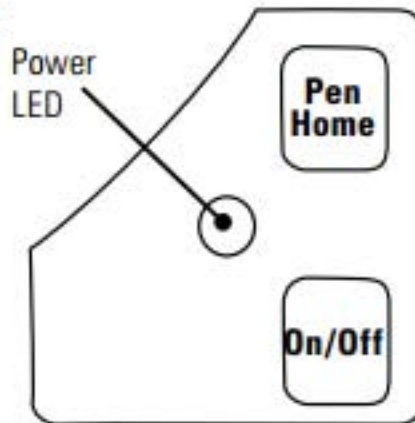

Pen Home

If the pens are located on the outside edge of the chart, press the **Pen Home** to move pen(s) to recording position. If the pens are located on the chart, press the **Pen Home** key to move the pen(s) to the outside edge of the chart.

Alarm TH623/625

Pen 1: = Red Pen
Pen 2: = Blue Pen

1. To set the alarm, make sure unit is on and press and hold the Alarm button. The LED will blink red rapidly for about five seconds, then the LED will turn solid green. Release the Alarm button and the LED will turn solid red. At this point the display will show "On" or "Off".
2. Pressing either the Adjust-Up or Adjust-Down buttons, located on the back of the unit next to the dip switch, will toggle the alarm on or off.

3. Pressing **pen home** will scroll to the next alarm options:
 - a. Alarm “on” or “off”
 - b. Pen 1 alarm minimum
 - c. Pen 1 alarm maximum
 - d. Pen 2 alarm minimum
 - e. Pen 2 alarm maximum
4. In order to set pen alarm minimums and maximums, pressing **Adjust-Up** will increase the alarm value, and pressing **Adjust-Down** will decrease the alarm value. There is acceleration if the **Adjust-Up** button is held down.

Repetitively pressing the **Pen Home** button will scroll through the five options until the alarm button is pressed to exit from alarm adjust. Each press of the **Pen Home** or **Alarm** button will store the new settings. The unit will take one minute to exit “Alarm Set Mode” once the **Alarm** button is pressed.

5. If the alarm is triggered, the LED will show as solid red and the alarm will sound. Press the Alarm button to silence the audible alarm.

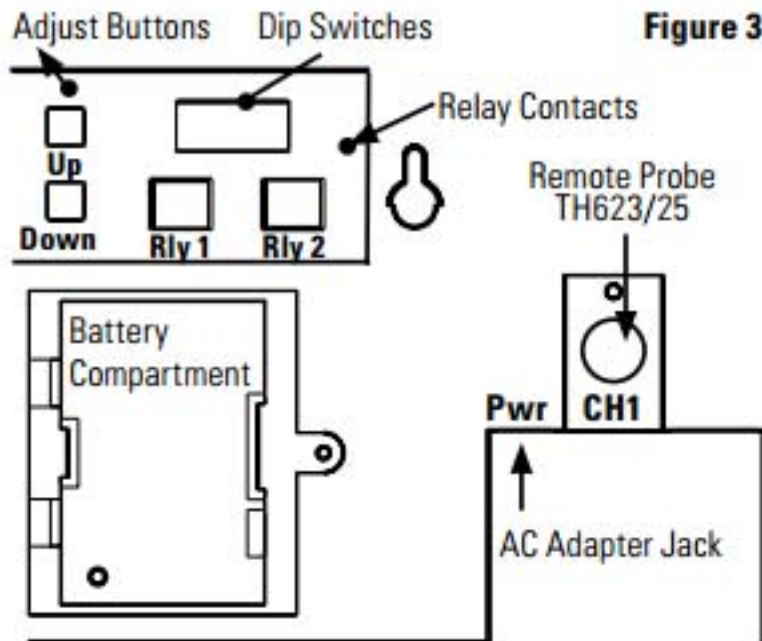

Dip Switch Settings

To set-up the TH6 recorder for your specific application, you might need to change some of the “Dip Switches”. The Dip Switches are located on the back of the unit. Use a pen or small screw driver to flip the switches.

Remember to install the correct chart to match the corresponding Dip Switch setting.

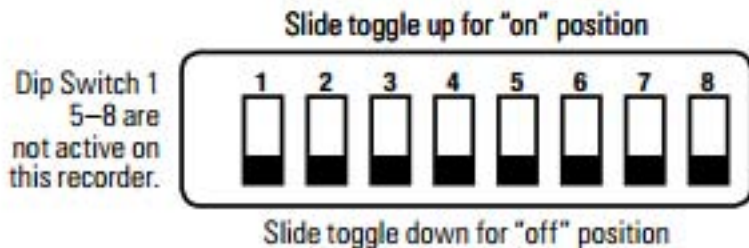

Dip Switches for ranges

Dickson TH6 Dip Switch Settings
Up=On Down=Off 25201

Switches 2-4F	Model	Chart	2	3	4
7-Day	All		D		
24-Hour	All		U		
0 to 100°F	TH623/25			D	D
+32 to +100°F	TH621/22	0 to 100		D	D
0 to +185°F	TH623/25	0 to 200		D	U
0 to +50°C	All			U	D
0 to +85°C	TH623/25	0 to 100		U	U

Remember to install the correct chart for your range.

Dickson Addison, IL www.DicksonData.com

Recording Time

The TH6 recorder has two different recording time options

- 24-hour 2 up
- 7-day 2 down

Note: Remember to install the correct chart to match corresponding switch setting.

Temperature Range

The TH6 will record up to 4 temperature ranges (depended on model). Dip switches 3 & 4 allow you to select the temperature range.

0 to +100°F	3 down
TH623/25	4 down
+32 to +100°F	3 down
TH621/22	4 down
0 to +185°F	3 down
TH623/25	4 up
0 to +50°C	3 up
TH621/22/23	4 down
0 to +85°C	3 up
TH623/25	4 up

Power

The TH6 operates on AC power with an optional 4 AA battery backup. Battery backup will last approximately 3 days.

Alarm and relays will not operate under battery only power.

LED Indicators

Green LED = "Power on"

Blinking Green = "Battery power"

Red = "Alarm" or "Low battery"

Blinking Red = "Alarm" or "Low battery while under battery power"

Calibration

Your instrument was carefully tested and calibrated before being shipped from the factory. For greatest accuracy, we recommend factory recalibration every 6-12 months.

If you wish to do the calibration yourself, follow these procedures:

1. To activate calibration mode, turn the unit on and press and hold both the On/Off button and the Adjust-Down button (making sure to press the Adjust-Down button first so the unit will not turn off).
2. The led will blink in amber rapidly for about five seconds, and turn solid green. Release the On/Off button and the Adjust-Down button, the led will then blink amber at which point only the pen being adjusted will show on the display.
3. To raise the unit of measurement, press the Adjust-Up button. To lower the unit of measurement, press the Adjust-Down button. Pen Home switches between the red and blue pens on a two-pen unit and stores the current adjustment value. When calibration is complete, press the On/Off

button. Calibration is stored in memory even after you turn the unit off. User calibration information will not be lost if AC power fails

Note: After two hours, if no buttons are pressed, the unit will “time out” of user calibration and resume normal operation. The user calibration is stored separately from the factory calibration. If you wish to cancel out your user calibration, simply enter “calibration mode” and toggle through the steps without adjusting displayed readings. Exit by pressing the On/Off button. You have now restored factory calibration.

It is recommended that you use a controlled chamber when calibrating temperature and humidity. Calibrating in an open room is not recommended as humidity can vary greatly within a very small area.

Need to know

Pen Adjust

Pen adjust may be needed if the pen(s) and display do not match.

1. While the unit is on, press and hold both the **Pen Home** button and the **On/Off** button (making sure to press the **Pen Home** button first so the unit will not turn off). The led will blink rapidly between amber and green for about five seconds, the LED will then turn green, release the **Pen Home** and **On/Off** buttons. The led will flash amber and green for one second and the led will turn off.
2. Both pens will move to the outer edge of the chart, and then the shorter red pen will move to the current position.

Use the **Adjust-Up** and **Adjust-Down** buttons to move the pen to the maximum temperature line on the chart. Once the shorter red pen is set, the **Pen Home** button will move the shorter red pen to the outer edge of the chart and the longer blue pen will move to its current position.

The **Adjust-Up** and **Adjust-Down** buttons will adjust the longer blue pen position. Once the pen is set, the **Pen Home** button will move the longer blue pen to the outer edge of the chart and the shorter red pen will move to its new position.

Each time **Pen Home** is pressed, the two pens will switch positions (moving the most recently adjusted position) until the **On/Off** button is pressed to exit pen adjust mode.

Note: Pressing the **On/Off** button will exit the adjustment and return the unit to normal operation. Each time the **Pen Home** or **On/Off** button is pressed, the adjustment currently in progress will be stored. The unit will take one minute to exit “Pen Adjust Mode” once the **On/Off** button is pressed.

Troubleshooting

Why isn't the chart keeping time or running slow?

- The chart may be hung up or restricted, possibly caused by a rip on the outer edge of the chart or the chart may be caught between the arm and pen arm platform.

- The incorrect chart is installed for the selected chart speed.

Why did the chart stop turning?

- Chart hung up or restricted, (ripped chart)
- The unit may be “locked up”.

This can be confirmed by pressing any of the buttons on the keypad. If the unit is “locked up”, there will be no response to button presses and the chart recorder may appear to be working, but the readings won’t change. Also, the chart will not rotate.

Remove the power and battery, and then re-power

Why don’t the display and chart match?

- Dip switches are set for a specific range, but using chart for another range, or vice versa.
- Pen(s) not inserted on pen arm(s), all the way. To adjust the pen to match chart, see “Pen Adjust” in the Need to Know section of this manual.

Why does the display read PROB?

Is the unit “locked up”?

This can be confirmed by pressing any of the buttons on the keypad. If the unit is ‘locked up’, there will be no response to button presses and the unit may appear to be working. The readings won’t change, and the chart will not rotate. Remove power and battery, and then re-power.

Why does calibration seem to be off?

-
- What is the tolerance of the unit it’s being compared to?
- It’s ok if the unit is within the sum of the two tolerances.
- Has an outside calibration house attempted calibration? It may not have been adjusted properly.
- Walk through calibration adjustment, found in the manual.

Why won’t the battery back-up work?

- Is there a good battery in the chart recorder?
- Keep in mind that battery back up lasts approximately 3 days. Temperature, pen movement and chart rotation speed will significantly affect battery life.
- If there was a momentary power outage “brown out”, the unit may not have had enough time to recognize this and switch to battery mode. (The chart recorder may lock up or shut off in this

situation) This situation may also occur if the unit is plugged into an outlet that shares the circuit with other machinery that has phase motors or compressors that cycle periodically. As these other machines cycle, they momentarily have a high current draw, therefore drawing from the unit.

Why won't the chart recorder respond to changes?

- Is the unit 'locked up'? this can be confirmed by pressing any of the buttons on the keypad, if the unit is 'locked up' there will be no response to button presses and the unit may appear to be working, but the readings won't change, also the chart will not rotate. Remove power and battery, and then re-power.
- Dip Switch 1 should be in the down position. If it is in the up position the pens will not move.

Why won't the unit power up?

Remove the battery and power adapter for a minute or two. This will reset the unit. The unit should respond when the adapter is plugged in.

Warranty

Dickson warrants that this line of instruments will be free from defects in material and workmanship under normal use and service for a period of twelve months after delivery.