



Manual F-20-TF-L
June 2008
Revision 1
www.dwyer-inst.com



MODEL TFP-LI
MODEL TFM-LI
MODEL TFP-LP
MODEL TFM-LP

Flow Sensors and Flow Meters For Liquids

Installation Manual & Operating Instructions



READ THIS MANUAL COMPLETELY BEFORE ATTEMPTING TO CONNECT OR OPERATE YOUR FLOW SENSOR. FAILURE TO DO SO MAY RESULT IN INJURY TO YOU OR DAMAGE TO THE FLOW SENSOR.



TABLE OF CONTENTS

A. Introduction	3
1. Unpacking.....	3
2. Product Overview And Principle Of Operation.....	3
B. Installation	5
1. General Considerations	5
2. Mounting The Flow Sensor Or Flow Meter	6
3. Tubing Connections	7
4. Electrical Connections	8
a) Overview	9
b) Connecting A Cable Assembly.....	9
c) Electrical Connections – Voltage Output Units (TFP-LI & TFM-LI Series)	10
d) Electrical Connections – Units With Both Voltage & Pulse Outputs (TFP-LP & TFM-LP Series).....	11
e) Using a 0-5VDC Output Power Adapter Package.....	12
C. Operation	13
1. Start-Up	13
2. Entrapped Air or Gas	13
3. Flow Readings	13
a) 0-5VDC Analog Outputs	14
b) Pulse Outputs	14
c) Units with an Integral Display.....	14
4. Operating at Flow Rates Outside the Calibrated Flow Range.....	15
a) Flows Above the Maximum Rated Flow.....	15
b) Flows Below the Minimum Rated Flow	16
5. Zero Adjustments	16
6. Recalibration	16
7. Calibrating Units for different Liquids.....	19
D. Maintenance And Product Care	19
1. General.....	19
2. Cleaning and Flushing	20
3. Returning Units For Repair Or Recalibration	20
E. Specifications	21
F. Dimensions	23
G. Connector Pin And Wire Color Cross Reference	27
H. Trouble Shooting Guide	28
I. Warranty	30
J. Contacting Dwyer	30

A. Introduction

1. Unpacking

All sensors are suitably packaged to prevent damage during shipping. If external damage is noted upon receipt of the package, please contact *the shipping company* immediately. Dwyer Instruments is not liable for damage to the device once it has left the manufacturing premises.

Open the package from the top, taking care not to cut too deeply into the package. Remove all the documentation and contents. Take care to remove all the items and check them against the packing slip. The products should also be checked for any concealed shipping damage. If any shortages or damage is noted, please contact the shipping company and/or Dwyer Instruments to resolve the problem.

Typical Contents of Box
Sensor, Calibration Certificate & Instruction Manual
(Model TFP-LP shown, other models similar).



CAUTION: Take care not to **drop** your sensor or subject it to sudden impact. Read the installation section of this manual before providing power or tubing connections to the unit. Any damage caused by improper installation or careless handling will not be repaired under warranty (see limited warranty on page 30 for more details).

2. Product Overview and Principle of Operation

TF Series Flow Meters and Flow Sensors for liquids are capable of measuring flows as low as 13-100 ml/min or as high as 1.0-10.0 l/min. Highly repeatable results are achieved using a patented Pelton Turbine

Wheel flow sensor design. This proven design minimizes zero drift while maintaining fast response and linear outputs with virtually no maintenance.

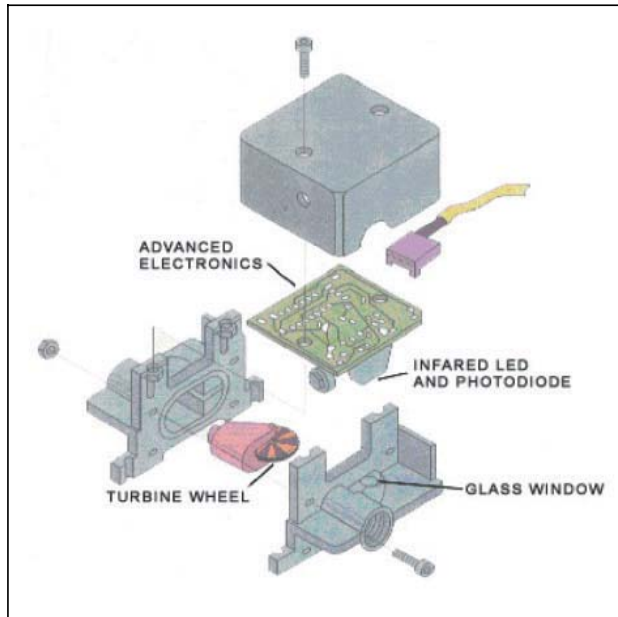

Patented technology measures flow using a miniature turbine wheel similar in size to a U.S. dime (16 mm diameter, 0.75 mm thick). The micro-turbine wheel is supported on a very small sapphire shaft that is held in position by two sapphire bearings. The micro-turbine assembly is so light that it virtually floats in the liquid. This relieves force on the bearings and almost eliminates wear.

As flow passes through the flow sensor, a precision machined nozzle directs the fluid onto the very small teeth of the micro-turbine wheel. This causes the wheel to spin at a speed proportional to the flow rate.

The micro-turbine wheel has alternating white and black sections evenly spaced on one side of the wheel. An infrared light beam is directed onto the wheel. As the wheel rotates the infrared beam is reflected off each white section. The reflected beam is detected by a phototransistor that converts the reflections into electrical pulses. As the wheel spins faster the pulse rate increases. Processing circuitry provides analog and/or pulse output that are linearly proportional to the flow rate

When the wheel stops (under zero flow conditions), no pulses are generated. Consequently, zero drift is not possible and zero adjustments are never required.

Every unit is supplied with a calibration certificate detailing the results obtained during calibration. Units are calibrated using deionized water as the reference media. Flowing liquids with different specific gravities or viscosities may affect the calibration.

B. Installation



CAUTION: Do not flow any gas through a liquid flow sensor. This may damage the micro-turbine assembly and void the warranty. Do not exceed the pressure, temperature or power operating ranges detailed in the Specifications section of this manual. Dwyer Instruments shall not be liable for any damage or injury caused by incorrect operation of their products.

1. General Considerations

It is recommended that a safety shut-off valve be installed upstream of (before) the sensor.

All wetted parts should be checked for compatibility with the liquid to be used. If there are any incompatibilities e.g. highly corrosive liquid, then the unit may be damaged or fail prematurely. Such damage will not be repaired under warranty.

Units should be installed in a clean, dry environment with an ambient temperature that is as stable as possible. Avoid areas with strong magnetic fields, strong air flows or excessive vibration.

If the liquid to be used may contain particles larger than 25 microns then a filter (25 microns or less) should be installed upstream of (before) the unit.

The required differential press (or pressure drop across the unit) decreases exponentially with decreases in flow rate.

Pressure Drop vs. Percentage of the Full Scale Rated Flow (may vary $\pm 10\%$ of indicated psid)

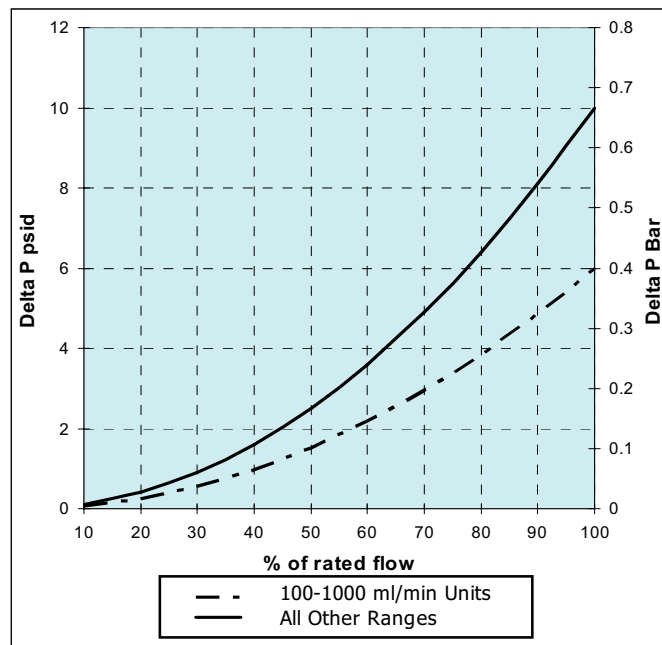

To calculate the pressure drop at a certain flow rate use the formula

$$\mathbf{PD = (YourFlow / MaxFlow)^2 \times PD_{max}}$$

PD = Pressure drop at YourFlow.

YourFlow = flow rate (ml/min or l/min)

MaxFlow = 100% rated flow for the sensor (in same units as YourFlow)

PD_{max} = Pressure drop at 100% rated flow (see chart above)

If the pressure available for the flow sensor is **BELOW** the pressure drop at the required flow then flow through the unit will not be possible.

For example: You have a sensor with a 50-500ml/min flow range and want to know the pressure drop (or minimum differential pressure required) at 300ml/min. According to the chart above, the pressure drop at 100% of flow is approx 10psi. Using the formula above:

$$PD = (300 / 500)^2 \times 10 = 3.6 \text{ psid}$$

Therefore, at 300ml/min the minimum required differential pressure for this unit is 3.6 psid. This means that if the available pressure is below 3.6psid then flow through the unit may not be possible.

Pressure drop through a system is cumulative. If the total pressure drop across all the components in a system exceeds the minimum pressure available then flow will not be possible.

For example: A system has a pressure of 30-40psi. There are several components and the sum of their pressure drops at the required flow rate is 32psid. If the system is operating at 30psi flow would not be possible as the total of the pressure drops would be greater than the pressure available. The system will only operate if the system pressure is above 32psi.

If there is any possibility that there may be bubbles or entrapped gas in the system then the outlet tubing should be elevated above the inlet port. This will enable any gas that may become entrapped in the unit to escape (see section C2 for details of how to remove entrapped air or gas).

2. **Mounting the Flow Sensor or Flow Meter.**

The TF Series of Flow Sensors and Flow Meters have no particular installation requirements so may be mounted in any convenient position.

It is recommended that units be fixed to a suitable substrate with #4 screws using the two mounting holes provided.

***Mounting The Sensor
(Mounting hardware not included with sensor)***

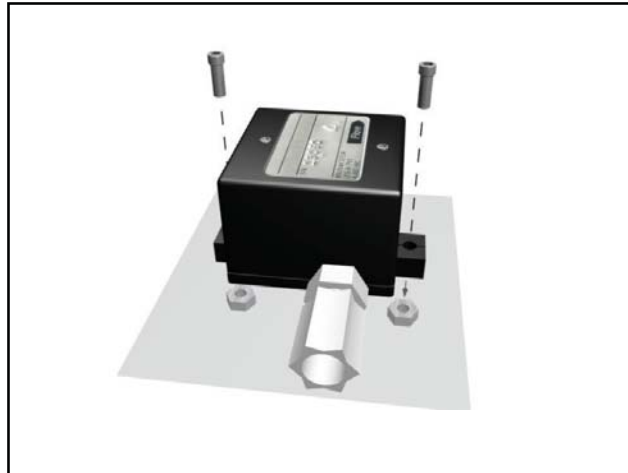

3. Tubing Connections



CAUTION: DO NOT FLOW ANY GAS THROUGH A LIQUID FLOW SENSOR OR FLOW METER. THIS WILL DAMAGE THE MICRO-TURBINE ASSEMBLY AND VOID THE WARRANTY.

All tubing must be clean and without crimps, burrs or scratches.

Only use the fittings factory installed on the unit. If the fittings are removed the calibration of the unit may be effected and leaking may occur. If different fittings are required please contact Dwyer Customer Service for assistance.

When connecting the sensor to the tubing a wrench should be used to stop the fitting rotating in the sensor body. Take care not to over tighten the fittings or leaking may occur.

Connecting and tightening the Fittings





CAUTION: DO NOT over tighten the fittings into the sensor body. Excessive force may damage the sensor body and will NOT be repaired under warranty.

The flow direction for the unit is clearly marked on the label. Do not reverse the flow direction or the unit will not function.

***Close Up of Label Showing Flow Directions
(All models similar)***

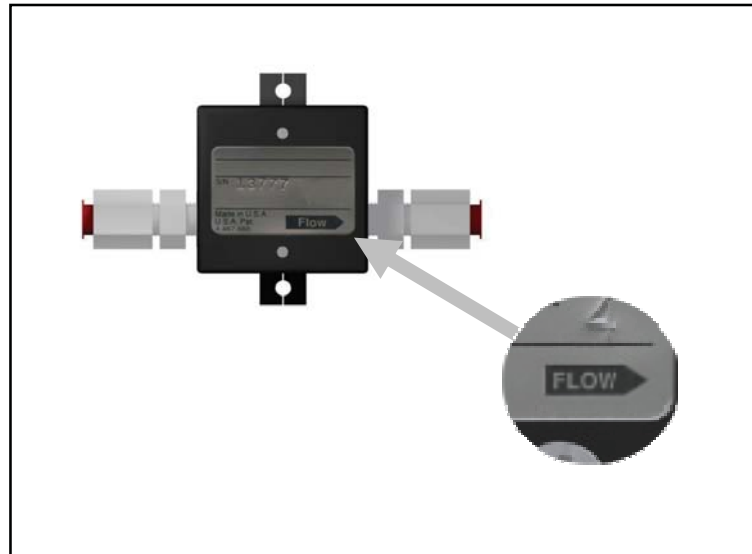

For the best results, precautions should be taken to minimize the amount of turbulence in the flow stream. Avoid valves, fittings, curves in the tube, and changes in the internal diameter or any other restrictions close to the inlet of the sensor. The tubing ID should be as large as possible and preferably not smaller than the ID of the fittings installed on the sensor.

For 0.2-2.0 L/min units a 10 cm straight length of tube before the sensor is recommended. For higher flow range units (0.5-5.0 L/min and 1.0-10.0 L/min), a 20 cm straight length of tubing before the sensor is recommended. If this is not possible it is recommended that straight lengths between all connections on the inlet side of the sensor are as long as possible and 90 degree fittings (with a large enough ID) are used instead of curves in the tubing.

4. Electrical Connections



CAUTION: Incorrect wiring may cause severe damage to the unit. Applying an AC voltage (115VAC or 230VAC) directly to the unit will cause damage. Read the following instructions carefully before making any connections.

a) Overview

The TFP-LP and TFM-LP series provide a 0-5VDC and pulse output proportional to the flow rate. This output may be connected to a display, data acquisition system or voltmeter.

The TFP-LI and TFM-LI feature an integral display that provides a local flow reading. These units also have a 0-5VDC analog output available. If required, this may be connected to another display, data acquisition system or voltmeter.

A stable D.C. power supply is required to operate the unit. The voltage and current requirements depend on the configuration of the unit. Full details may be found in the Specifications section of this manual.

Connecting wires should be as short as possible to avoid voltage drops. Twisted 2 pair conductor cable should be used if the length of the power wires is to be longer than 1 meter.

Units are supplied with an integral 4 pin connector. Connections to the unit are made using a mating cable assembly or power adapter package as detailed in the following sections (parts 4.b to 4.e of this manual). A connector pin and wire color cross reference may also be found in Appendix G (Page 27) of this manual.

b) Connecting the Cable Assembly

The connector on the end of the cable assembly should be pushed into the mating socket on the sensor taking care to ensure that it is the correct way up.

Connecting the Cable Assembly (All models similar)

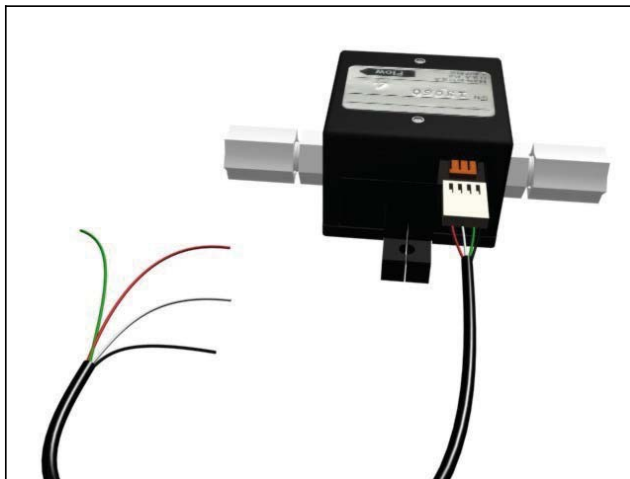

Electrical Connections are made to the cable assembly as detailed in the following sections.

c) Electrical Connections – Voltage Output Units (TFP-LI & TFM-LI Series)

The cable assembly should be connected to the sensor as detailed in section 4(b) above. Power should not be applied to the sensor until all the connections have been made and checked. Electrical connections should be made as follows:

Wiring Schematic For Voltage Output Units.

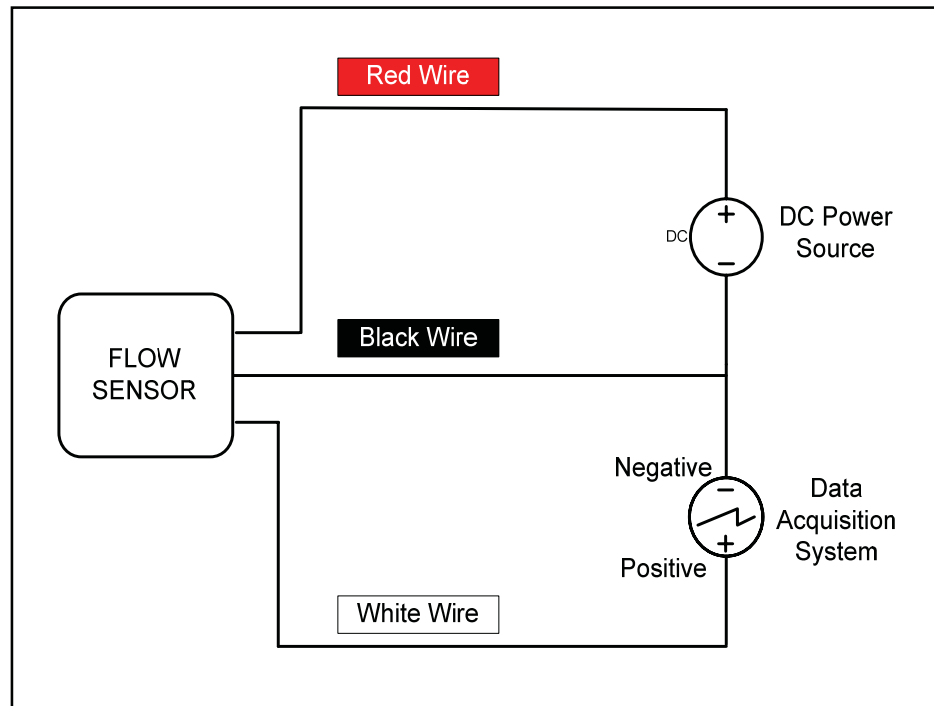

The **RED** wire should be connected to the Positive of the power source.

The **BLACK** wire should be connected to the Negative (Ground) of the power source.

The **WHITE** wire provides the signal output and should be connected to the positive terminal of the display, data acquisition system or voltmeter with an impedance of greater than 2500 Ω (Ohms).

The **GREEN** wire (if present) is NOT used



CAUTION: Avoid high voltage static discharges to any of the connections. Do not short the input/output signal wires or allow them to contact the power wires at any time. **DAMAGE WILL RESULT!**

d) Electrical Connections –Units with Both Voltage and Pulse Outputs (TFP-LP & TFM-LP Series)

The cable assembly should be connected to the sensor as detailed in section 4(b) above. Power should not be applied to the sensor until all the connections have been made and checked.

Wiring Schematic For Voltage and Pulse Output.

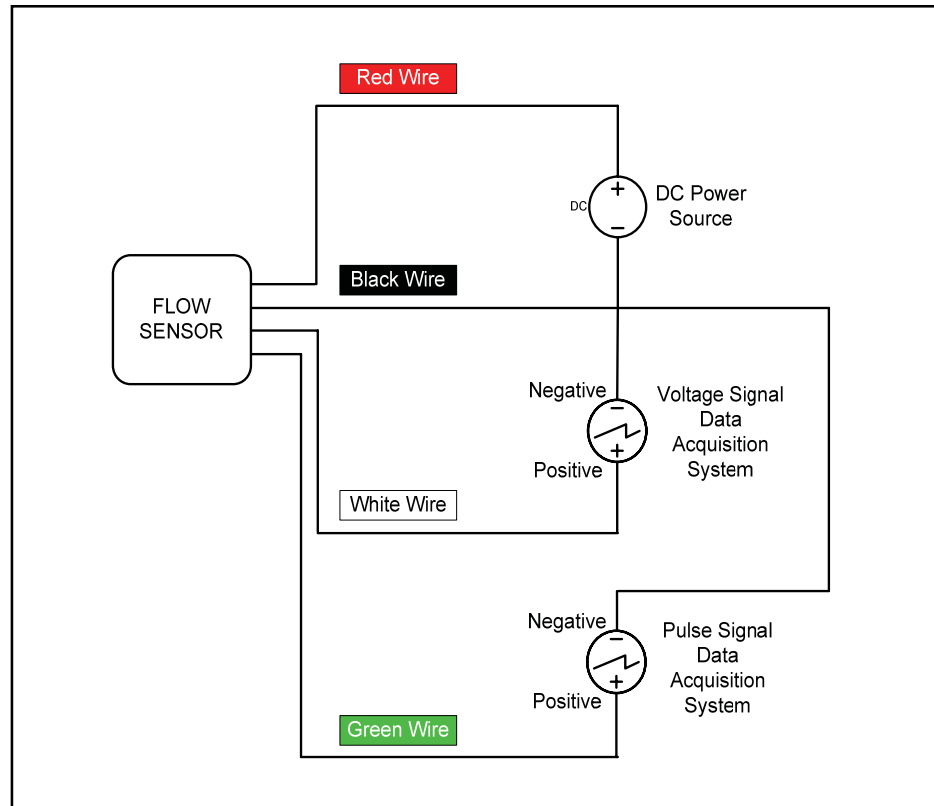

The **RED** wire should be connected to the Positive of the power source.

The **BLACK** wire should be connected to the Negative (Ground) of the power source.

The **WHITE** wire provides the signal output and should be connected to the positive terminal of the display, data acquisition system or voltmeter with an impedance of greater than 2500 Ω (Ohms).

The **GREEN** wire ("T" option only) is the pulse output and should be connected to the Positive terminal of the data acquisition system with an impedance of greater than 10K Ω (Ohms).

The PULSE and VOLTAGE output may be monitored simultaneously.



CAUTION: Avoid high voltage static discharges to any of the connections. Do not short the input/output signal wires or allow them to contact the power wires at any time. **DAMAGE WILL RESULT!**

e) Using a 0-5VDC Output Power Adapter Package.

An optional 0-5VDC Output Power Adapter Package is available for use with the TF Series. This consists of a power source (115VAC or 230VAC) and cable assembly with pig-tail (soldered wire) ends for the signal output. This should be assembled as shown in the following diagram.

***Connecting the Power Adapter to the Flow Sensor
(All other models similar)***

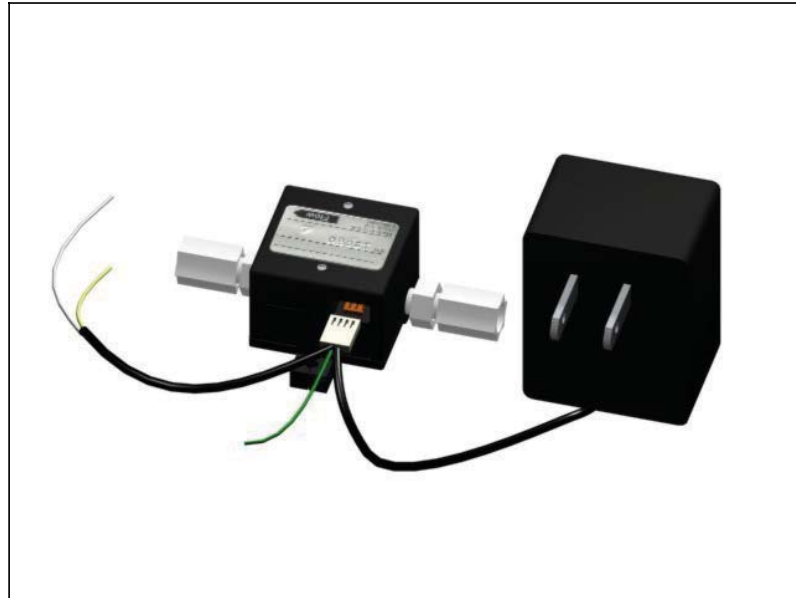

Electrical connections to the cable assembly should be made as follows:

YELLOW WIRE: This provides the 0-5VDC signal output and should be connected to the positive terminal of the display, data acquisition system or voltmeter with an impedance of greater than 2500 Ω (Ohms).

GREEN WIRE: For Pulse output units the green wire provides the pulse output and should be connected to the positive terminal of the data acquisition system with an impedance of greater than 10K Ω (Ohms).

WHITE WIRE: This is the signal negative and should be connected to the negative (ground) terminal of the voltmeter, display or data acquisition system.



CAUTION: Avoid high voltage static discharges to any of the connections. Do not short the output signal wires or allow them to contact the power wires at any time. DAMAGE WILL RESULT!

C. *Operation*



CAUTION: USE WITH LIQUIDS ONLY. FLOWING GAS OR AIR THROUGH YOUR FLOW SENSOR WILL DAMAGE THE MICRO-TURBINE ASSEMBLY. THIS TYPE OF DAMAGE WILL NOT BE REPAIRED UNDER WARRANTY.

1. **Start Up**

Before applying power to the unit check all tubing and electrical connections. Once correct installation is verified switch on the power.

2. **Entrapped Air or Gas**

There may be a lot of air or gas trapped in your sensor after installation. This will usually escape the unit when flow (within the range of the unit) is first started.



CAUTION: The system should be primed with liquid and flow started gradually. This will prevent trapped air or gas from being forced through the sensor at a high velocity that may damage the sensor.

If gas remains entrapped in the unit it may be necessary to elevate the outlet tubing above the inlet of the sensor. This should enable the trapped gas to escape the unit. The sensor may be returned to its original position once all the gas has escaped.

If elevating the outlet tubing does not work, block or pinch the outlet tube whilst there is flow in the system. After approximately 5 seconds, release the restriction to allow normal flow. Doing this will build up pressure in the flow path that when released will help remove the entrapped gas. Repeat this until the entrapped gas is removed from the unit.

3. **Flow Readings**

TFP-LP and TFM-LP Series sensors provide a 0-5VDC and pulse output proportional to the flow rate.

The TFP-LI and TFM-LI Series feature an integral display that provides a local flow reading and a 0-5VDC analog output.

Each flow sensor is factory calibrated for a specific flow range. The flow range is shown on the unit's label and calibration certificate. Units are calibrated using deionized water as the reference media.

a) 0-5VDC Analog Outputs

By monitoring the voltage output signal it is possible to determine the flow rate of the liquid. Units are configured so that an output signal of 5.0VDC is provided when the maximum flow (i.e. Full Scale flow) is passing through the unit. The output signal is linear and scalable enabling calculation of flow rates within the sensor's range. For example:

For a flow range of 50-500ml/min:

At 500ml/min the output signal would be 5VDC

If the output signal were 3.5VDC then the flow rate would be:

$$500 \div 5 \times 3.5 = 350\text{ml/min}$$

If the maximum flow rate is exceeded non-linear and inaccurate readings will result.

b) Pulse Outputs

By monitoring the Pulse output frequency it is possible to determine the flow rate of the liquid. The pulse frequency for maximum flow through the unit (i.e. full scale flow) is detailed on the calibration certificate. This differs from unit to unit. This output is approximately linear and scalable within the sensor's range. For example:

For a flow range of 1.0-10.0l/min:

The calibration certificate gives the following:

At 10.0l/min the pulse output signal is 312Hz

At 5.0l/min the pulse output signal is 150Hz

At 2.0l/min the pulse output signal is 58Hz

If the output signal were 120Hz then the flow rate would be:

$$5.0 \div 150 \times 120 = 4.0 \text{ l/min (using the closest calibration point)}$$

c) Units With an Integral Display

The TFP-LI and TFM-LI Series feature an integral 3 ~ digit LCD display. This is configured to read in ml/min for flow ranges up to 50-500 ml/min and in l/min for all other flow ranges. The display will only operate if power is applied to the unit.

Flow readings may be taken directly from the display or by monitoring the 0-5VDC analog output provided by using a cable assembly or power adapter package (see above).

***LCD Flow Display
(TFM-LI Series Shown, other models similar)***



4. Operating at Flow Rates Outside the Calibrated Flow Range



CAUTION: If the flow through the unit exceeds 120% of the maximum rated (full scale) flow the unit may be damaged. This type of damage will not be repaired under warranty.

Flow measurement is only accurate within the calibrated flow range for the unit. This is detailed on the calibration certificate. The unit will still operate, to some degree, outside this flow range.

Results obtained when operating outside the specified range of the unit are not accurate but may be considered repeatable.

a) Flows Above the Maximum Rated Flow.

If the flow rate is above the maximum rated (or full scale) flow, the unit will still operate and provide an output signal proportional to the flow rate.

Flows must not exceed 120% of the maximum rated flow or the unit may be damaged.

b) Flows Below the Minimum Rated Flow.

Signal outputs may be obtained at flow rates below the minimum specified for your unit. The amount of flow that may be measured below the minimum specified varies from unit to unit.

5. Zero Adjustments

It is impossible for there to be any zero drift so zero adjustments are never required.

6. Recalibration

The calibration of the flow sensor may be easily verified using empirical methods.

It should be noted that the use of empirical methods outside a certified calibration laboratory is subject to inaccuracy and error. These methods should only be used to gain an indication of a sensor's performance. Please contact Dwyer Customer Service if accurate, certified recalibration is required.

A typical empirical calibration check may be carried out as follows:

Carefully adjust the flow rate so that the maximum output signal is obtained. With the flow rate constant, liquid flowing through the unit should be gathered in a container over a timed interval. The total volume flowed over the timed period should then be measured using a measuring cylinder. The actual flow rate (in the same units as the flow sensor calibration certificate) may then be calculated. The actual maximum flow rate should then be compared to the specified maximum flow rate to determine the error in calibration. For example:

For a flow range of 20-200ml/min with a 0-5VDC output:

With a constant flow and constant 5VDC output the actual volume measured over 30 seconds was 102ml.

Therefore the actual flow rate is:

$$(102 / 30) \times 60 = 204\text{ml/min}$$

The error is therefore $204 - 200 = 4\text{ml/min}$ or 2%

A second empirical check should be made at a flow rate below the maximum for the unit e.g. at 50% of full scale. The calculated percentage error at this flow should then be compared to the error at maximum flow. If there is a big difference in the percentage errors then the flow signal is no longer linear and the unit may be damaged (consult Dwyer Customer Service).

Once it has been determined that the linearity is still acceptable and the error in flow reading at maximum flow has been calculated, there are 3 options:

i.) Minor adjustments to actual calibration of the flow sensor may be made by turning the gain potentiometer on the side of the unit. For example:

For a unit with a flow range of 13-100ml/min and a 0-5VDC output:

With a constant flow and constant 5VDC output the actual volume measured over 60 seconds was 103ml.

The correct voltage output for a flow of 103 ml/min is:

$$(5/100) \times 103 = 5.15 \text{ V}$$

With the flow at a constant 103 ml/min the gain potentiometer should be carefully adjusted so that a voltage output reading of 5.15 V is obtained.

If the unit cannot be suitably adjusted please contact Dwyer Customer Service. Pulse outputs are not adjustable.

***Adjusting the Gain Potentiometer Using a Flat Head Screwdriver
(TFP-LP Series shown, other models similar)***

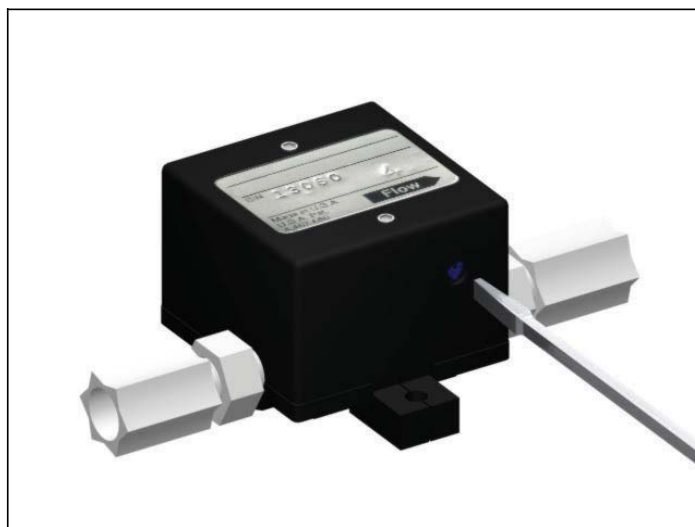

ii.) Adjust the scaling endpoints in the display or data acquisition system. For example:

For a flow range of 50-500ml/min with a 0-5VDC output:

With a constant flow and constant 5VDC output the actual volume measured over 60 seconds was 405ml.

Therefore the actual flow rate is:

$$(405 / 60) \times 60 = 405\text{ml/min}$$

The display or data acquisition system may now be configured as follows:

0 VDC = Zero flow
5VDC = 405ml/min

iii.) Apply the error factor to each flow reading taken. For example:

For a flow range of 0.2-2.0l/min connected to a display:

With a constant flow rate of 2.0 l/min on the display, the actual volume measured over 20 seconds was 0.7l

Therefore the actual flow rate is:

$$(0.7 / 20) \times 60 = 2.1 \text{ l/min}$$

The error is therefore $2.1 - 2.0 = 0.1 \text{ l/min}$ or 5%

If the display shows an uncorrected flow rate of 1.4 l/min then :

Corrected flow rate = Uncorrected flow rate + error

$$\text{Corrected flow rate} = 1.4 + 5\% = 1.47 \text{ l/min}$$

7. Calibrating Units for Different Liquids

The TF Series for liquids will operate with most translucent liquids subject to compatibility of the wetted parts. Best results are obtained with low viscosity (less than 10 centistokes) liquids. For information regarding higher viscosity liquids, contact Dwyer Customer Service.

Units are calibrated with deionized water as the reference media. Using other liquids will affect the calibration. The amount of calibration error will depend on the characteristics of the liquid being flowed.

The error in flow reading (or calibration) should be calculated and utilized as detailed in section 6 above.

D. Maintenance and Product Care

1. General



CAUTION: Do not disassemble your flow meter or flow sensor for any reason. If the unit appears to be malfunctioning please contact Dwyer Customer Service.

The TF Series of flow sensors require no periodic maintenance if used within the recommended specifications.

The next recommended recalibration date is stated on the calibration certificate supplied with the unit. Please contact Dwyer Customer Service for further information.

Inlet filters should be periodically checked and cleaned / replaced as necessary.

Regularly check all electrical and process connections for damage or deterioration.

If the sensor is to be stored, keep both the inlet and outlet ports sealed.

Do not store a sensor with any chemical other than water (or air) inside it over an extended period of time. Prolonged exposure to chemicals other than water may lead to precipitation or corrosion.

2. Cleaning and Flushing

If there is a buildup of deposits or residues from the measured chemicals it may be necessary to clean *or flush* the unit. This should be done by flowing clean, particle free water through the unit at a flow rate, pressure and temperature within the specifications of the unit. If necessary, flow may be reversed to assist flushing.

Under no circumstances should gas or air be flowed through the unit. This will cause severe damage.

3. Returning Units for Repair or Recalibration

To return units for repair or recalibration please contact Dwyer Customer Service. A Return Material Authorization (RMA) Number will then be issued to enable the unit to be returned. Please note that no returns will be accepted unless the RMA number is clearly indicated on the outside of all packages.

Once the unit has been received it will be evaluated and the cost of any repairs / recalibration determined. Once agreement has been received to pay for all the necessary work the unit will be processed and returned. No charges will be made for Warranty Repairs.

Dwyer Customer Service may be contacted as follows:

Mailing address: Dwyer Instruments Inc.
P.O. Box 373, 102 Indiana Hwy. 212
Michigan City, IN 46361
U.S.A.

Phone: U.S.A. (800) 872-9141 or (219) 879-8000
Fax: U.S.A. (219) 872-9057

Email: tech@dwyer-inst.com

Website: www.dwyer-inst.com

E. Specifications

	Model TFP-LP	Model TFM-LP
Analog Signal Accuracy (including linearity)	±1.0% Full Scale ¹	
Repeatability	±0.2% Full Scale ¹	
Pressure Rating	100 psig (6.8 bar)	500 psig (34.5 bar)
Temperature Rating	Operating Range: 5 to 55 °C Storage Range: 0 to 70 °C	
Temperature Sensitivity	±0.2% F.S. ¹ or less per °C	
Wetted Materials	Ryton® Epoxy Glass Sapphire	316 Stainless Ryton® Epoxy Glass Sapphire
O-Ring Material	Viton®	
Fitting Material (Standard)	Acetal	Stainless Steel
Fitting Material Optional	Kynar PVDF Brass Stainless Steel	Acetal Kynar PVDF Brass
Recommended Filtration	25 microns or less	
Compatible Liquids	Low viscosity (ideally <10cS) Translucent or transparent Minimum amount of entrapped air or gas	
0-5VDC Output Signal	Standard Minimum 2.5 KΩ load	
Pulse Output Signal	7.5VDC peak buffered square wave Typically 0-400Hz ±3.0% Full Scale accuracy	
Typical Power Consumption	12 VDC @ 35 mA (11.5-15 VDC)	
Response Time	Typically <1 second for 63% of final value	
Reliability	100,000 hours MTBF	
Certifications	CE Approved 89/336/EEC (EN 55011 & EN 50082-1) 73/23/EEC Low Voltage Directive	
Ratings	IP10 (NEMA 1)	
Warranty	1 year limited	

1. Specifications from 10-100% of rated flow. Linearity is best fit straight line. All calibrations performed with deionized water unless otherwise stated on calibration certificate

	Model TFP-LI	Model TFM-LI
Display	3.5 Digit Non Backlit LCD, 0.39" (10mm) high digits	
Accuracy (including linearity)	±1.0% Full Scale ¹	
Repeatability	±0.2% Full Scale ¹	
Pressure Rating	100 psig (6.8 bar)	500 psig (34.5 bar)
Temperature Rating	Operating Range: 5 to 55 °C Storage Range: 0 to 70 °C	
Temperature Sensitivity	±0.2% F.S. ¹ or less per °C	
Wetted Materials	Ryton® Epoxy Glass Sapphire	316 Stainless* Ryton® Epoxy Glass Sapphire
O-Ring Material	Viton®	
Fitting Material (Standard)	Acetal	Stainless Steel
Optional Fitting Materials	Acetal, Kynar PVDF, brass, or stainless steel	
Recommended Filtration	25 microns or less	
Compatible Liquids	Low viscosity (ideally <10cS) Translucent or transparent Minimum amount of entrapped air or gas	
0-5VDC Output Signal	Standard Minimum 2.5 KΩ load	
Typical Power Consumption	12 VDC @ 35 mA (11.5-15 VDC)	
Response Time	Typically <1 second for 97% of final value	
Reliability	100,000 hours MTBF	
Certifications	CE Approved 89/336/EEC (EN 55011 & EN 50082-1) 73/23/EEC Low Voltage Directive	
Ratings	IP10 (NEMA 1)	
Warranty	1 year limited	

1. Specifications from 10-100% of rated flow. Linearity is best fit straight line. All calibrations performed with deionized water unless otherwise stated on calibration certificate

F. *Dimensions*

ALL DIMENSIONS IN INCHES (MILLIMETERS IN BRACKETS)

Model TFP-LP For Liquids
1/4" Acetal Fittings Shown

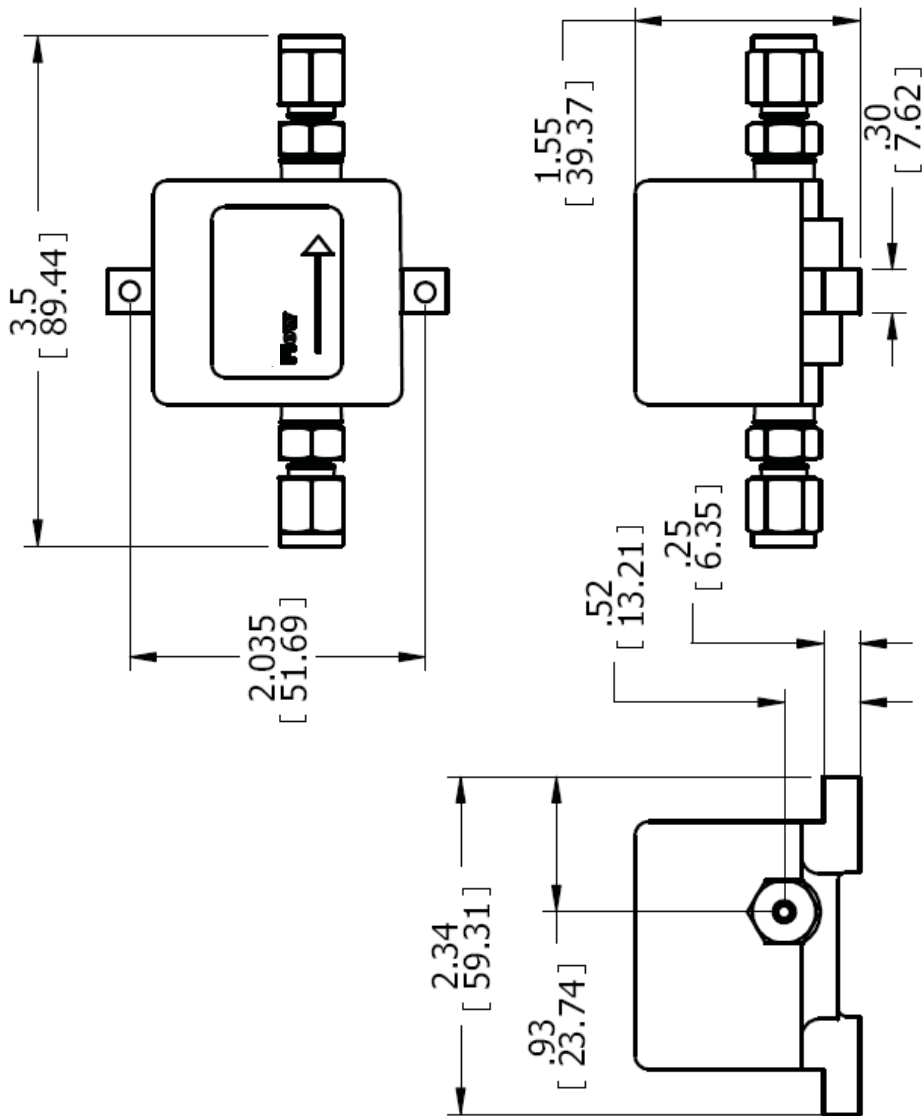

Model TFM-LP For Liquids
1/4" Stainless Fittings Shown

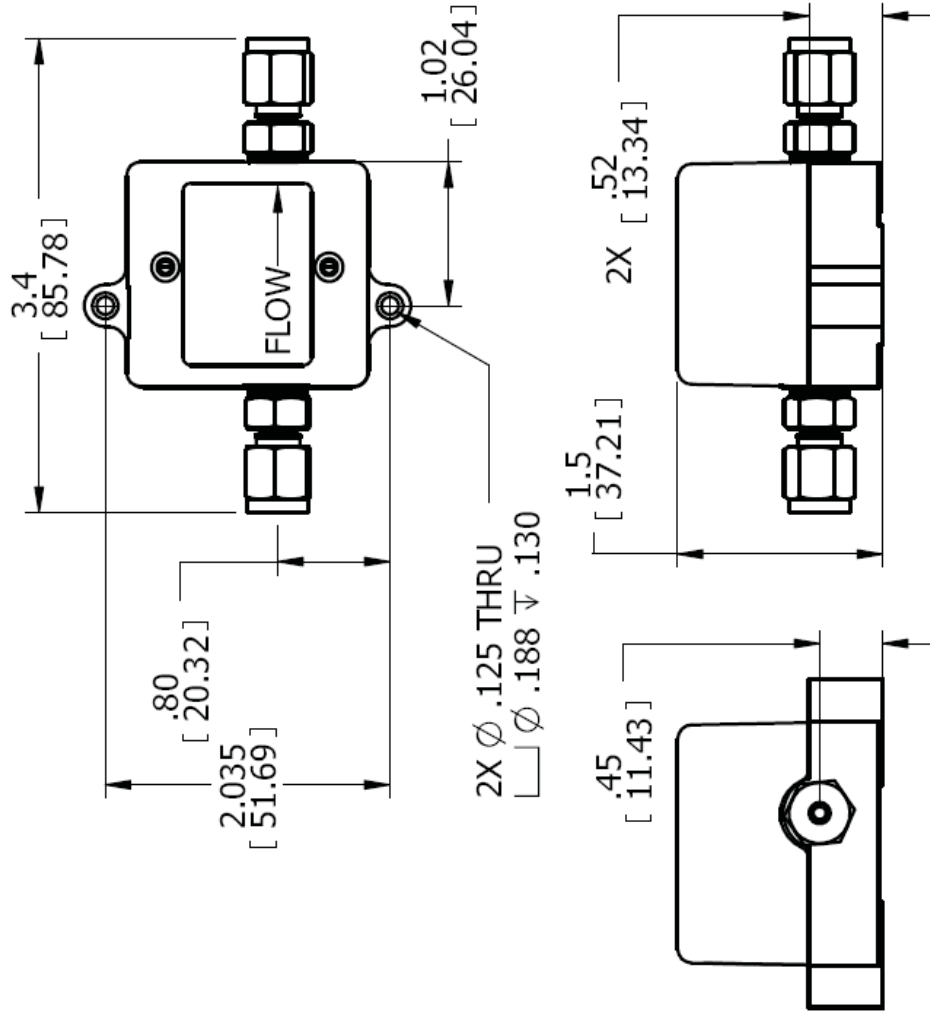

Model TFP-LI For Liquids
1/4" Acetal Fittings Shown

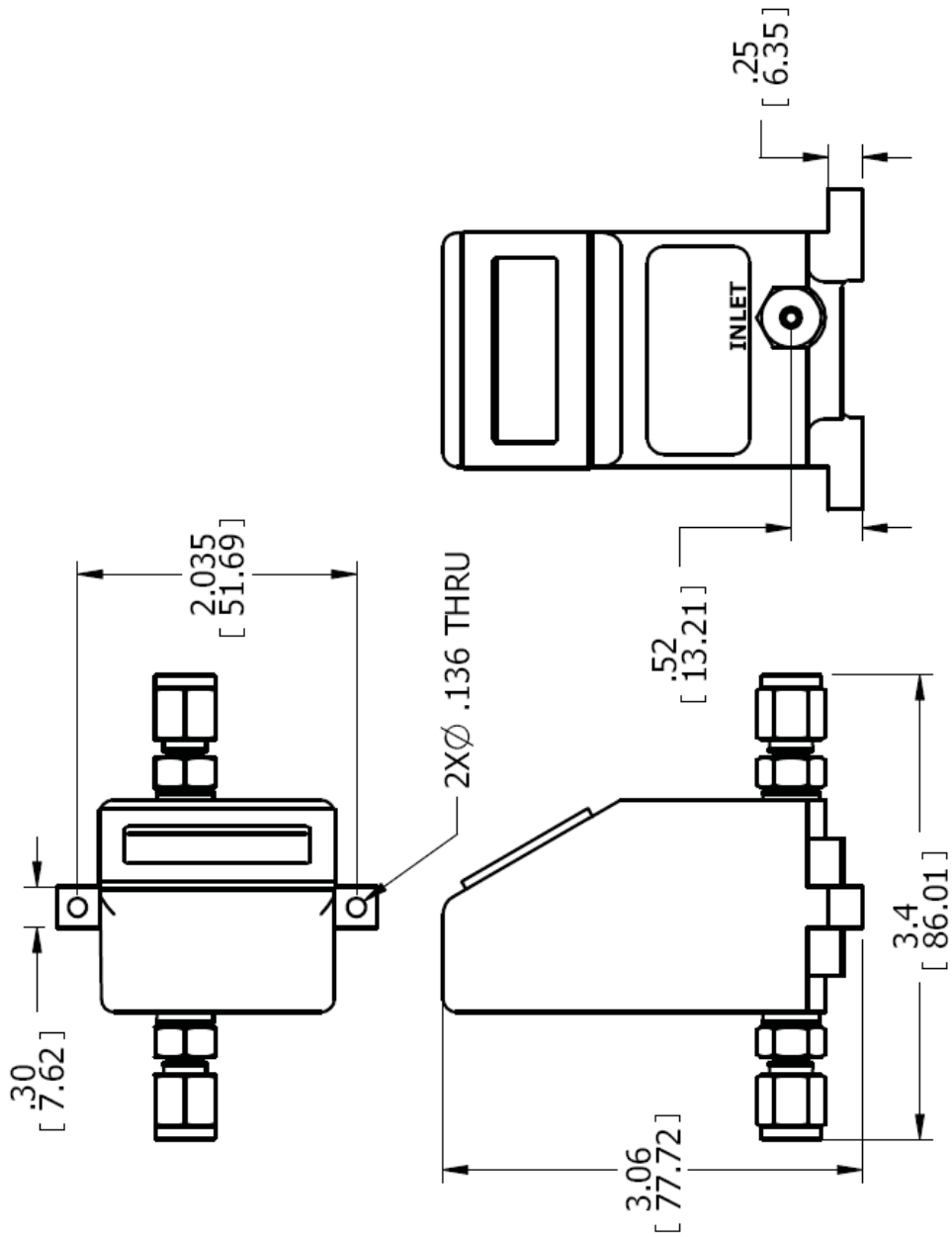

Model TFM-LI For Liquids
1/4" Stainless Fittings Shown

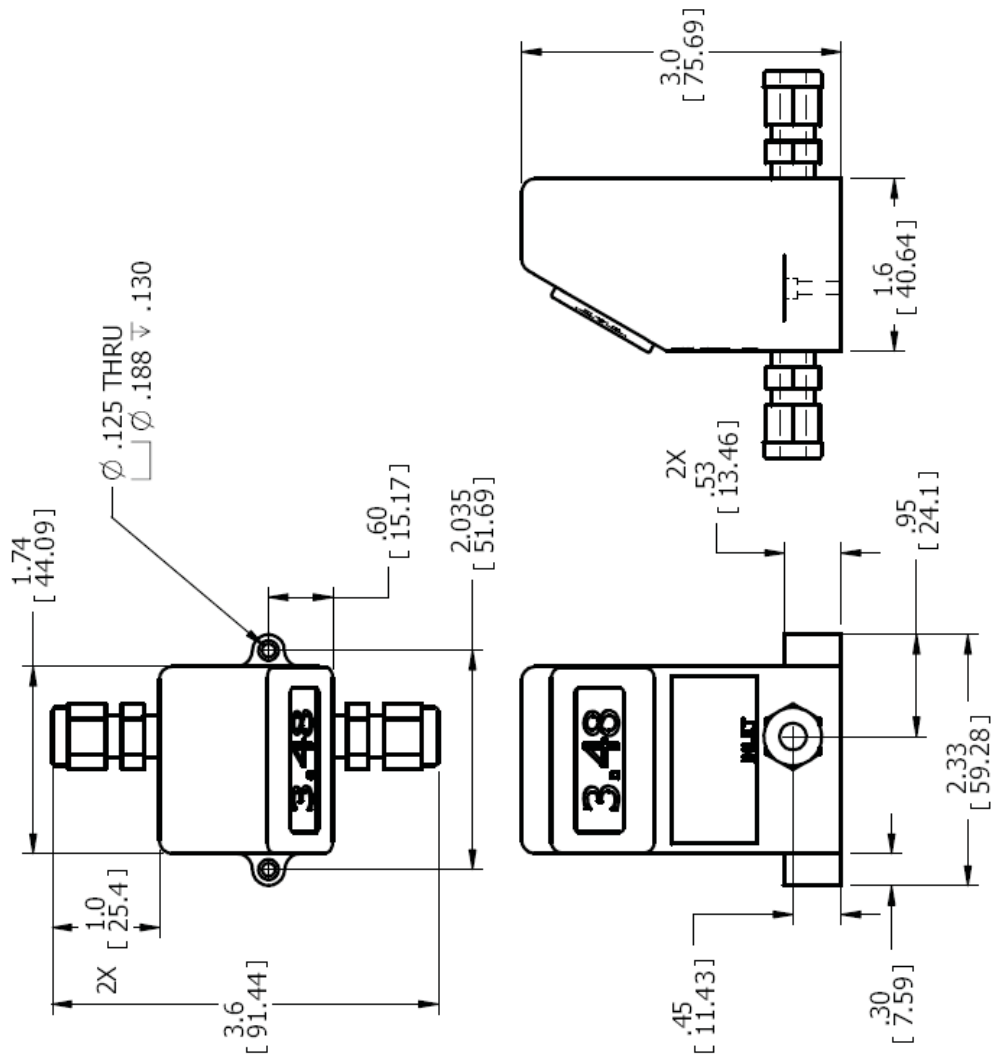

G. Connector Pin & Wire Color Cross Reference

End On View of Connector Socket and Connector

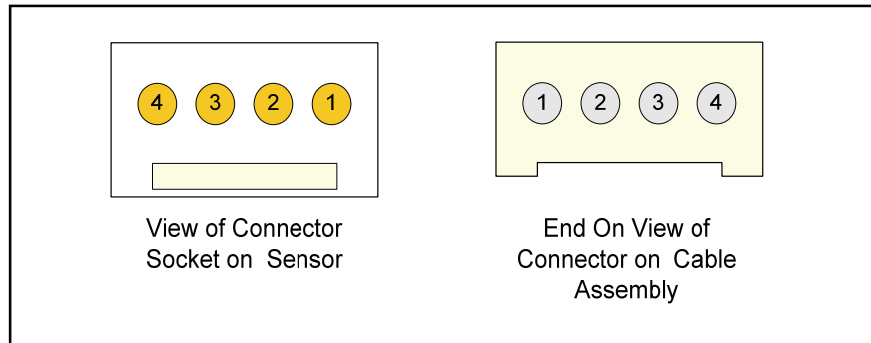

Standard Units:

Pin	Cable Wire Color	Unit Output	
		Voltage (TFP-LI & TFM-LI)	Voltage & Pulse (TFP-LP & TFM-LP)
1	Black	Signal & Power Negative (Ground)	Signal & Power Negative (Ground)
2	White	Voltage Output	Voltage Output
3	Red	Power Positive	Power Positive
4	Green	Not Used	Pulse Output

H. *Troubleshooting Guide*

Symptom	Possible Cause	Method of Correction
Unit Leaks.	Fittings not tight enough. Sensor assembly cracked.	Tighten fittings (see section B3). Unit must be returned for repair (see Section D3).
No output signal or flow indication.	No power or low power. No flow passing through unit. Output shorted or overloaded. Improper connection. Moisture on internal electronics. Output circuitry damaged. Liquid not translucent enough. Attempting to measure flows below the specified minimum for the unit.	Apply correct power. Display or output should read zero if there is no flow. Increase the flow rate until a reading is obtained. (Do not exceed the specified maximum flow!). Check electrical connections (see section B4). Check electrical connections (see section B4) and ensure connector is correctly plugged in. Allow unit to dry out in a dry environment. Unit must be returned for repair (see Section D3). Contact Dwyer Customer Service for assistance. Use higher flow rates.
Flow reading accuracy is outside the specification.	Liquid has a different viscosity and / or specific gravity than water at 20°C. Entrapped air or gas. Mechanical sensor assembly damaged.	Calculate the flow reading error / offset as explained in section C6/C7. Remove the entrapped air (see section C2). Unit must be returned for repair (see Section D3).

Symptom	Possible Cause	Method of Correction
Flow indication is not linear and output too low at lower flows	Attempting to measure flows below the specified minimum for the unit	Use higher flow rates.
	Liquid is too viscous	Best results are obtained with liquids that have a viscosity of 10cS or less. Contact Dwyer Customer Service for further information.
	Entrapped air or gas	Remove entrapped air (see section C2).
Flow indication "bounces" or fluctuates	Mechanical sensor assembly damaged	Unit must be returned for repair (see Section D3).
	Flow is actually fluctuating	Correct flow source to obtain steady flow.
	Not using the fittings supplied by the manufacturer	Use the supplied fittings.
	Entrapped air or gas	Remove entrapped air (see section C2).
	Turbulence in tubing or sensor	Straighten the inlet tubing or lengthen it to at least 6" (150mm) (see section B3).
Flow indication is fixed at one value	Fluctuating input power	Correct the power source or change to a regulated supply.
	Mechanical sensor assembly damaged	Unit must be returned for repair (see Section D3).
Flow indication is fixed at one value	The maximum rated flow for the unit is being exceeded.	Reduce the flow.
	Output circuits may be damaged	Unit must be returned for repair (see Section D3).