

TED Pro ENERGY MONITORING AND CONTROL SYSTEM

SINGLE AND THREE-PHASE ELECTRICAL SERVICES WORLDWIDE

OVERVIEW

The TED Pro Energy Monitoring and Control System is a state-of-the-art system for use in residential, commercial and government buildings and small industrial complexes. The system allows the user to monitor energy usage, thereby managing energy use through awareness of energy use and costs. Energy use and alerts can be presented on a custom display, computer, over the Internet, on mobile devices or by text or email messages. Colored LEDs alert the user to rate-tier changes, high demand, cost or other user-defined parameters.

Optionally, the system can be configured to automatically adjust thermostat settings or turn off loads based on user-selectable criteria such as cost of electricity, total use, cost, time of day, budget, or request from a utility or electric provider.

The system is designed to work on any single or 3-phase electrical system anywhere in the world and is compatible with numerous energy or demand-rate billing systems, including fixed, time-of-use, step/tiered, seasonal, demand, or any combination of those mentioned. The system also accommodates taxes, fixed charges, and fuel surcharges to accurately reflect the monthly electric bill.

The basic system consists of an MTU and an ECC, descriptions of each follow below.

The Measuring Transmitting Unit (MTU) measures the energy consumption, demand, voltage, current, and power factor. We offer three types of MTU depending on the requirements of your electrical system:

- **MTU Pro** is designed for 3-phase systems in small-to-medium size commercial, institutional and industrial environments. It is suitable for any 3-phase system up to 5000A, 600V.
- **MTU Lite** is designed for 3-phase wye systems in small business applications where maximum amperage is 200A and maximum voltage is 277V. It is also ideally suited for residential occupancies with 3-phase services, common in some parts of Europe and South America.
- **MTU Home** is designed for single-phase residential and small commercial use with a maximum amperage of 400A and 240V.

The MTU is generally located at the main electrical panel and transmits the information collected, over the building's existing electrical wiring, using a state-of-the-art Power Line Carrier communication (PLC) to an ECC which receives and interprets the data. Multiple MTUs can be used to give individual measurement of panels or loads. For systems with solar, wind or other generation, multiple MTUs will tell the user consumption, generation and net, from-or-to the utility. For utility-deployment, the MTU can be mounted in a Meter Collar for simple installation without entering the customer's premises.

The Energy Control Center (ECC) is the communication hub for the system. It receives raw energy-use data from the MTU(s), interprets the data and calculates the current energy cost, cost today, month-to-date, etc. The ECC can be configured to communicate with display devices, computers, networks, mobile devices, thermostats, and load control devices via Ethernet, PLC, WiFi, ZigBee, USB, or XBee. System can be configured to send text or e-mail alerts using the free TED Advisor feature.

Multiple ECCs in multiple locations can be monitored via the internet using TED's proprietary AggreData software.

System and Utility Rate setup is simple and intuitive using a PC running our web-based setup wizards. For utilities, rates and setup configuration can be pre-programmed making the entire system plug-and-play. The ECC can also be configured to receive data from a ZigBee Smart Meter.

To this basic system can be added numerous options:

- Multiple MTUs can be added to separately measure various loads or generation.
- **TED Spyder** – The Spyder mounts in, or beside the electrical panel and is connected to the MTU. The Spyder records detailed usage of up to 8 single or multi-phase circuits. These individual readings are stored in the ECC for display. Each TED system can support up to 4 MTUs and 4 Spydres, thus monitoring up to 36 separate loads.
- Multiple systems can be used and the data aggregated at a central location.
- Display Devices
 - Wired-in Display connects directly to ECC.
 - Optional Wireless Display with battery backup can be mounted anywhere or carried around for load checking.
- Smart Thermostats
 - WiFi or ZigBee-based
- Load Shedding Devices
 - PLC, WiFi or ZigBee-based

ECC (Energy Control Center)



MTU Pro



MTU Lite / MTU Home



Spyder

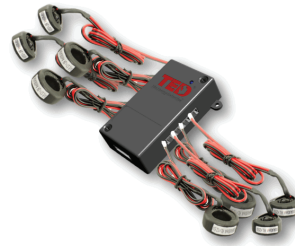

How TED Works



TECHNICAL SPECIFICATIONS

Measuring Transmitting Units (MTUs)

	Pro	Pro Lite	Pro Home
Types of Services			
Single-phase 2-Wire or 3-Wire	Yes	Yes	Yes
3-phase 4-Wire Wye	Yes	Yes	No
3-phase 3-Wire Delta	Yes	No	No
3-phase 4-Wire Hi-leg Delta	Yes	No	No
Frequency	50/60 Hz	50/60 Hz	50/60 Hz
Maximum Voltage - Phase/Phase	600 V	n/a	n/a
Maximum Voltage - Phase/Neutral	347 V	277 V	240 V
Minimum Voltage	180 V	95 V	95 V
Maximum Current - per phase	5000A *	200A	400A**
Maximum Wire Size	500 MCM (23mm OD)*	4/0 AWG (15mm OD)	4/0 AWG (15mm OD)
Voltage Measurement	Voltage Divider Circuit	Voltage Divider Circuit	Voltage Divider Circuit
Current Measurement	400A:3V Split-Core CTs	200A:1.5V Split-Core CTs	200A:1.5V Split-Core CTs
Operating Temperature	-40°C<T _A <+50°C	-40°C<T _A <+50°C	-40°C<T _A <+50°C
Energy Measurement and Calculations	ADE 7854ACPZ	Cirrus CS5461A	Cirrus CS5461A
Overall Accuracy	*** Better than ± 2%	*** Better than ± 2% 1-phase, ± 4% 3-phase	*** Better than ± 2%
Measure and Transmit Energy	± 1W	± 1W	± 1W
Measure and Transmit Demand	± 1VA	± 1VA	± 1VA
Measure and Transmit Voltage	± 0.1V	± 0.1V	± 0.1V
Measure and Transmit Phase Currents	± 0.01A	± 0.01A	± 0.01A
Measure and Transmit Power Factor	± 0.1%	± 0.1%	± 0.1%
Communication Interface	PLC / Ethernet	PLC	PLC
PLC System	Yitran IT700 System	Yitran IT700 System	Yitran IT700 System
Tested and Approved to:	FCC Part 15, UL916, CSA C22.2#205, IEC 61010-1		

* Will measure up to 5000A with three 400A parallel feeds using additional CT sets. For systems over 1200A please contact TED Customer Service.

** Will measure up to 400A with two parallel 200A using additional CT set or with optional 400A CT set.

*** From 1.5% to 100% of Full Scale

Data-Receiving Units

	Energy Control Center (ECC)
Works w/ 3-phase & single phase MTU	Yes
Maximum Voltage Phase/Neutral	277 V
Minimum Voltage Phase/Neutral	95 V
Frequency	50/60 Hz
Cord Types Available	UL / EU / UK / AU
Operating Temperature	+5°C<T _A <+40°C
Communication Methods Available	PLC, Ethernet, USB, XBee
USB 2.0 Port	1

Data-Receiving Device	
	Energy Control Center (ECC)
USNAP 2.0 Port	2
Display Port	1
Compatible w/ ZigBee SE 2.0 smart meter	Yes
Accept Demand Reduction Request from Utility	Yes
Maximum number of MTUs on one system	4
Maximum number of Spydres on one system	4
Maximum number of Loads Measured	36
Power-on LED	Blue
Link Status LED	Green / Yellow
Transmit / Receive	Green / Red
Energy-Use Indicator Bar	Green / Yellow / Red

OPERATIONAL SPECIFICATIONS

	Energy Control Center (ECC)
Software	
TED Footprints™ - Historical, Graphical, Profiling, TED Advisor, Aggredata	Included
TED Smart Load-Shedding Software	Included - Avail 3 rd Qtr
System and Utility Rate Setup	Wizard Setup
Solar / Wind Generation	
Display System Load	Yes
Display System Generation	Yes
Display Net Metering	Yes
Data Display Options	
Computer - TED Footprints™ Software	Yes
Desktop LCD Display	Yes
Wireless LCD Display	Yes
Mobile Phones or Pads	Yes
AggreData - Aggregates data from multiple systems	Yes
Third Party Applications	Yes
Data Storage / Display	
Second Data	Every second for 2 hours
Minute Data	Every minute for 48 hours
Hour Data	Every hour for 90 days
Day Data	Every day for 2 years
Month Data	Every month for 24 years

	Energy Control Center (ECC)
Rate Structures	
Rates downloadable from Internet	Yes
Rates can be pre-programmed	Yes
Number of TOU Rates	4
Number of Tier/Step Rates	4
Critical Peak Rates	Yes
Weekend Rates	Yes
Holiday Rates (US and Canada)	Yes
Seasonal Rates (4 seasons)	Yes
Tier/Step within Seasons	Yes
Tier/Step within TOU periods	Yes
TOU Rates within Seasons	Yes
Demand Charges or Demand Penalties	Yes
Number of House Codes	unlimited
Update Time	1 Second

TED Pro Series Dimensions



ECC – Energy Control Center

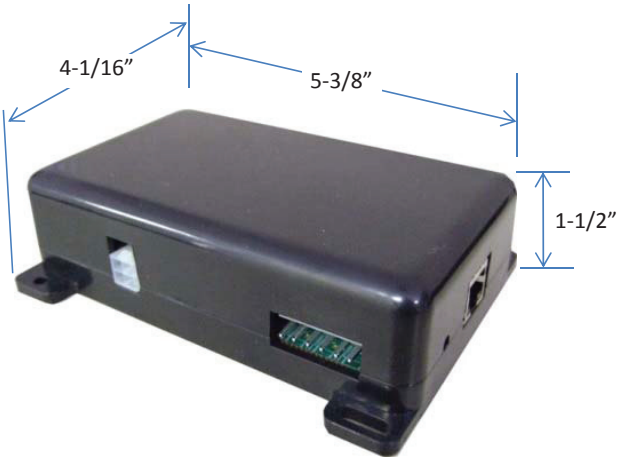

Pro MTU and MTU-RC

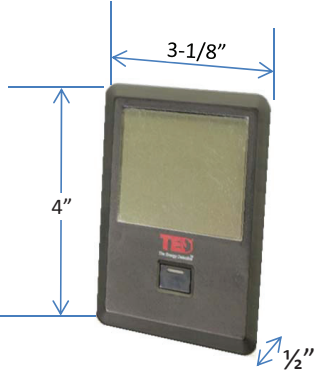

Wired and Wireless Display

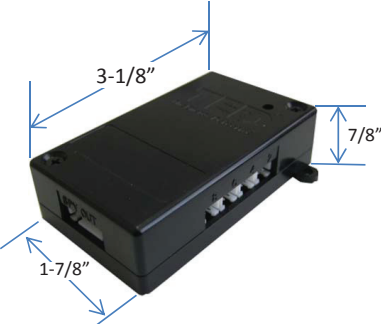

Spyder

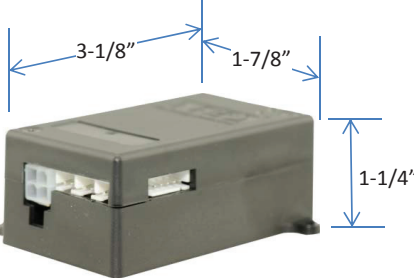

MTU Home and Lite

TED Pro Current Transformers

CT601B - 200A Split-core CT

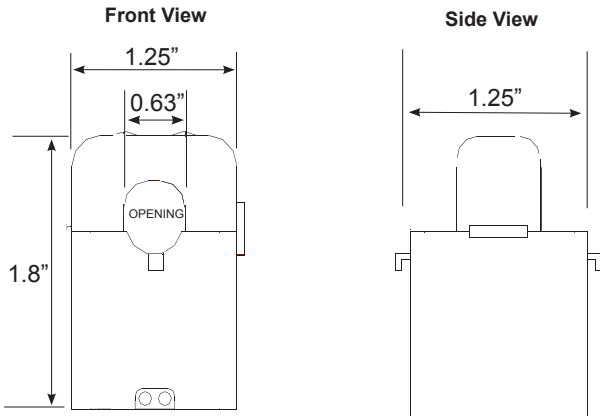

CT400XL - 400A Large Split-core CT

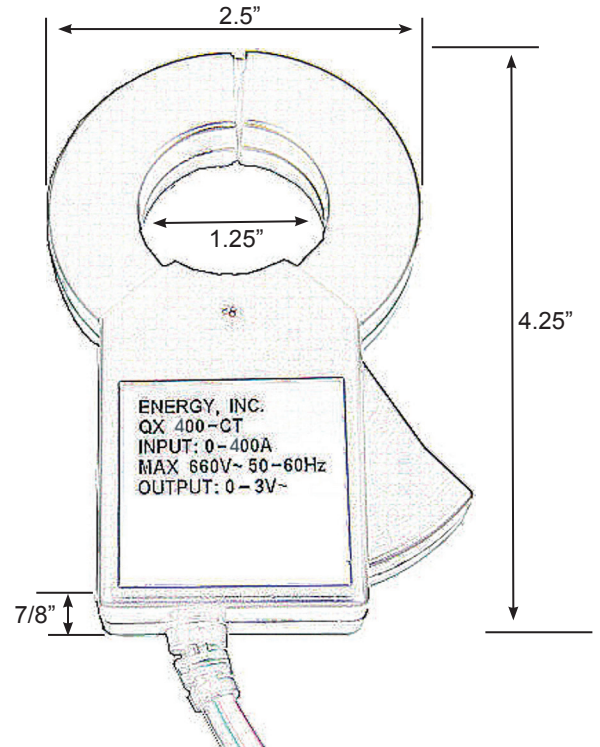

CT301 - 400A Standard Split-core CT

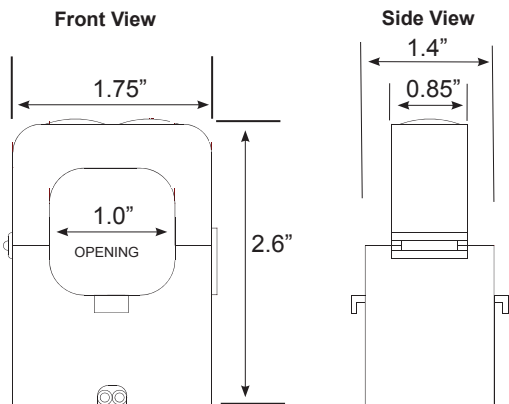

All CT Wire: UL1015 22AWG PVC Wire (600V)

TED Pro 400A Current Transformers

CT301 - 400A Standard Split-core CT

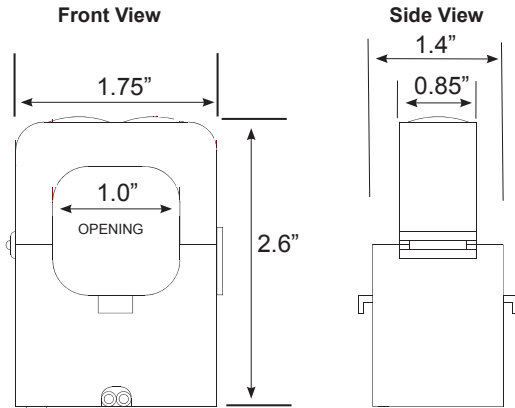

CT Wire: UL1015 22AWG PVC Wire (600V)

CT400XL - 400A Large Split-core CT

