

# Series 8000 Meter

## User Guide



WEB VERSION

## TABLE OF CONTENTS

<b>Warnings and Cautions</b> .....	2
<b>1. Introduction</b> .....	3
Section 1.1 Meter Features System Description .....	3
Section 1.2 Series 8000 System Specifications .....	3
Table 1: Series 8000 Meter System Specifications .....	4
Front Panel Display .....	5
Figure 1: Series 8000 Front Panel .....	5
Figure 2: Series 8000 Internal View .....	6
Figure 3: Product Dimensions .....	7
Figure 4: Product Wiring Diagram .....	8
<b>2. Safety Precautions</b> .....	9
Section 2.1 Electrical Safety Compliance .....	9
<b>3. Installation</b> .....	10
Section 3.1 Pre-Installation .....	10
3.1.1 Pre-Installation Checklist .....	11
3.1.2 Site Planning .....	11
3.1.3 Installation Procedures .....	11
3.1.4 Mounting the Series 8000 .....	11
Figure 5: 120V Mounting Layout, Dimensions and Clearances .....	12
3.1.5 Installing Potential Transformers for 3PH Service greater than 277V .....	13
Figure 6: Potential Transformer Chassis .....	13
Figure 7: Typical 3PH 347V Installation .....	14
3.1.6 Installing the Sense Voltage and Control Voltage Cables in Wye and Delta Services .....	15, 16
Figure 8: 120/240V Single-Phase Connection .....	17
Figure 9: 120/240V Three-Phase Wye panel with 120V variant .....	18
Figure 10: 120/208V Three-Phase Wye panel version with a Wiring Harness .....	19
Figure 11: 277/480V Three-Phase panel with 120V variant .....	20
Figure 12: 277/480V Three-Phase panel with 277V variant .....	21
Figure 13: 347/600V or higher 3PH Wye panel with PTs with the 120V variant .....	22
Figure 14: 3PH Delta panel with 120V variant .....	23
<b>4. Installing Current Transformers</b> .....	24, 25
<b>5. Connecting the Ethernet Communications</b> .....	26
<b>6. Connecting the Modbus RTU Communications</b> .....	27
Figure 15: Modbus Wiring Diagram .....	27
<b>7. Start-Up Sequence</b> .....	28
Section 7.1 Manually Testing Communications .....	28
<b>8. Pulse Inputs</b> .....	29
<b>9. Display Navigation</b> .....	30
Section 9.1 Normal Mode .....	30
Section 9.2 Diagnostic Mode .....	30
<b>10. Configuration Tool Installation</b> .....	31
Section 10.1 Network and Meter Setup .....	31
Section 10.2 Connecting to S8000 Meter .....	32, 33
<b>11. Regulatory Compliance</b> .....	34
<b>12. Warranty</b> .....	35

## WARNINGS AND CAUTIONS

### HAZARD OF ELECTRICAL SHOCK, EXPLOSION, OR ARC FLASH

- **TO AVOID DEATH, PERSONAL INJURY OR PROPERTY DAMAGE**, disconnect service voltage from the panel and use caution when working around energized circuits.
- Ensure the installation is completed per NEC® guidelines as well as local codes.
- A disconnect must be provided (such as a breaker from the panel) that will allow shut off of power to the meter for servicing.
- Voltage references to the meter should be connected to a circuit breaker in the panel and/or with appropriate fusing based on the NEC® and any local codes that are applicable.
- Apply appropriate personal protective equipment (PPF) and follow safe electrical work practices. See NFPA 70E.
- This equipment must only be installed and serviced by qualified electrical personnel.
- Always use a properly rated voltage sensing device to confirm power is off.
- Replace all devices, doors and covers before turning on power to this equipment.
- The meters must be connected to the sense voltage and control voltage through a properly rated voltage disconnect (not shown in the wiring diagrams).

**Failure to follow these instructions will result in death or serious injury.**

## IMPORTANT NOTES

- Please refer to the product manual or call/E-mail the Leviton® Meter Support Team for further assistance.
- For the full listing of tools and equipment required for the complete installation of this product, please refer to the manual for details.
- **347/600 V** and **480 V** Delta services require external PTs to step down the voltages before being wired to the meter.

## INTRODUCTION

### 1. INTRODUCTION

This document describes the Series 8000; including procedures to install and start up the unit, and complete the initial configuration:

- "System Description"
- "Pre-Installation"
- "Installation Procedures"
- "Start-Up Sequence"
- "Fuse Replacement"

This documentation is intended for those responsible for installing and configuring the Series 8000 meters. Installers must be qualified electricians with knowledge of local and national code requirements. See "Safety Precautions".

#### 1.1 Meter Features System Description

The Series 8000 meters support:

- Single-Phase, 2-wire
- Single-Phase, 3-wire (network)
- Three-Phase Wye and Delta services

Depending on how the meters are installed and configured, they can meter 8, 12, or 24 individual meter points. The Series 8000 meters are designed for residential, commercial, and industrial use and display the power and consumption readings for each measurement point.

#### 1.2 Series 8000 System Specifications

The Series 8000 system architecture includes:

- Single-Phase, 2-wire; Single-Phase, 3-wire (network); and Three-Phase compatibility
- 120/208V, 120/240V and 277/480V configurations, and 347/600V with external potential transformers
- Up to 8, 12, or 24 individual meter points
- Local Ethernet configuration interface via PC and web browser
- Ethernet ports for remote reporting
- Modbus serial port for remote reporting
- Serial port for remote display
- 2 pulse inputs to connect metering devices

## INTRODUCTION

**Table 1: Series 8000 Meter System Specifications**

Specification	Series 8000 Model: S8UTS/277TS	Series 8000 Model: S8UWH/277WH
Dimensions	Height: 13.125 in. (33.5 cm) Width: 12 in. (30.5 cm) Depth: 2.125 in. (5.5 cm)	Height: 13.125 in. (33.5 cm) Width: 12 in. (30.5 cm) Depth: 2.125 in. (5.5 cm)
Weight	8.77 lb (3.98 kg)	8.77 lb (3.98 kg)
Sense Voltage	100V to 300V 50/60Hz 2W+N+Protective Earth Wye 3W+N+Protective Earth Wye 3W+Protective Earth Delta	100V to 300V 50/60Hz 2W+N+Protective earth 3W+N+Protective Earth Wye 3W+Protective Earth Delta
Control voltage and current	North America: 120V 125 mA 60 Hz International 230-240V 63 mA 50/60 Hz	North America: 120V 125 mA 60 Hz International 230-240V 63 mA 50/60 Hz
Current Transformers Measurement Category III	100mA  Note: All CTs used with the product must be UL recognized/listed.  For CT Part Numbers (see S8000 Data Sheet)	100mA  Note: All CTs used with the product must be UL recognized/listed.  For CT Part Numbers (see S8000 Data Sheet)
Measurement Accuracy (accuracy compliant when used with 0.3% CTs)	ANSI C12.20 Class 0.5 IEC 62053-22 Class 0.5S	ANSI C12.20 Class 0.5 IEC 62053-22 Class 0.5S Measurement Canada Approved EG07 compliant
Pulse inputs 1 and 2	Dry form A and solid-state form A compatible Maximum frequency 10 Hz Minimum pulse width 20 ms	Dry form A and solid-state form A compatible Maximum frequency 10 Hz Minimum pulse width 20 ms
Non-volatile memory storage	120 days in 15 minute intervals	120 days in 15 minute intervals
On-board Ethernet port	10/100 Mb/s	10/100 Mb/s
On-board Modbus serial port	RS422 or RS485 19200/9600 Baud	RS422 or RS485 19200/9600 Baud
Serial port	115 kb/s	115 kb/s
Fuse rating (F1)	North America: 120V: T125 mA, 250V International 230V: T63 mA, 250V	North America: 120V: T125 mA, 250V International 230V: T63 mA, 250V
Environmental		
Operating Temperature	-40 to 70°C	-40 to 70°C
Operating humidity	5% to 90% non-condensing	5% to 90% non-condensing
Usage environment	Indoor or enclosed outdoor environment	Indoor or enclosed outdoor environment
Maximum altitude	9843 ft (3000 m)	9843 ft (3000 m)
Pollution degree	2	2

## INTRODUCTION

### Front Panel Display

The Series 8000 meters have the following front panel features (Figure 1):

- **LCD** - displays 2 rows of 16 characters for each of the meter points (8, 12, or 24)
- **Display button** - cycles through the available information for each of the meter points
- **Left and right arrow buttons** - selects which of the meter points is on the display

Figure 1: Series 8000 Front Panel



## INTRODUCTION

Figure 2 shows the internal view of the Series 8000

**Figure 2: Series 8000 Internal View (Meter Only)**

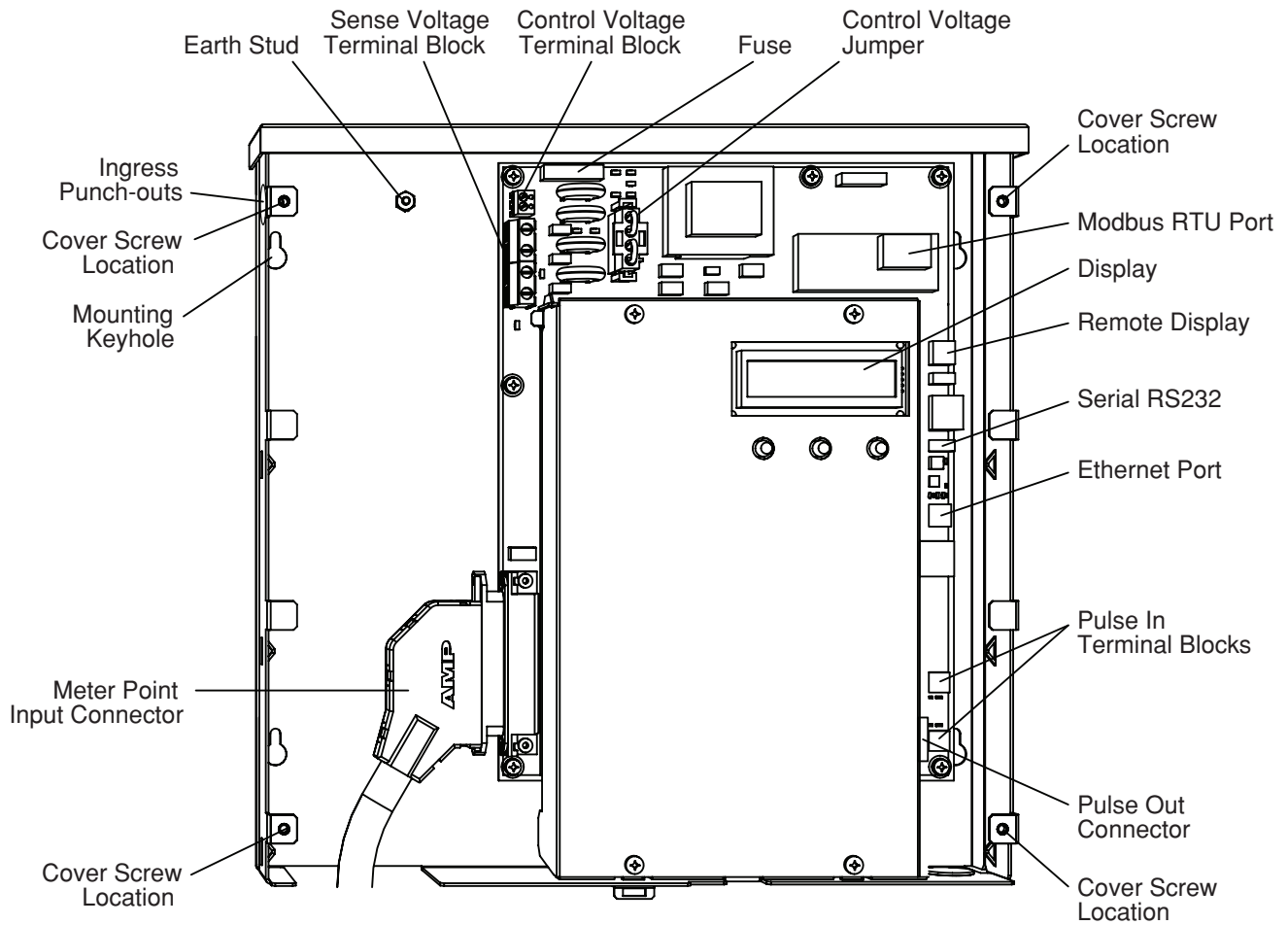

## INTRODUCTION

Figure 3 shows the dimensions of the Potential Transformer, Series 8000 Meter and CT Termination enclosure.

**Figure 3: Product Dimensions**

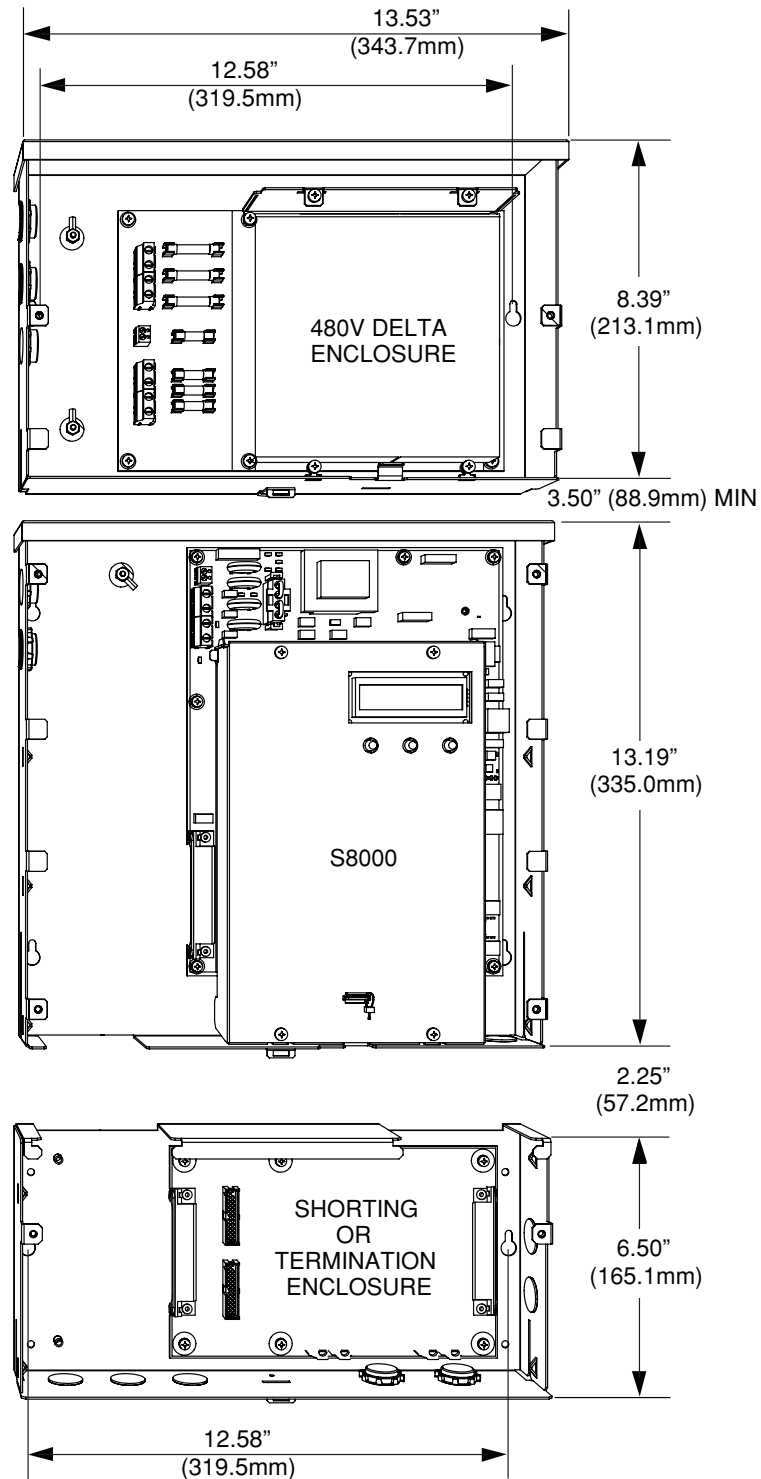

## INTRODUCTION

Figure 4 shows the a functional diagram of how all possible components fit together for a 3 Phase 3 wire installation.

**Figure 4: Product Wiring Diagram**

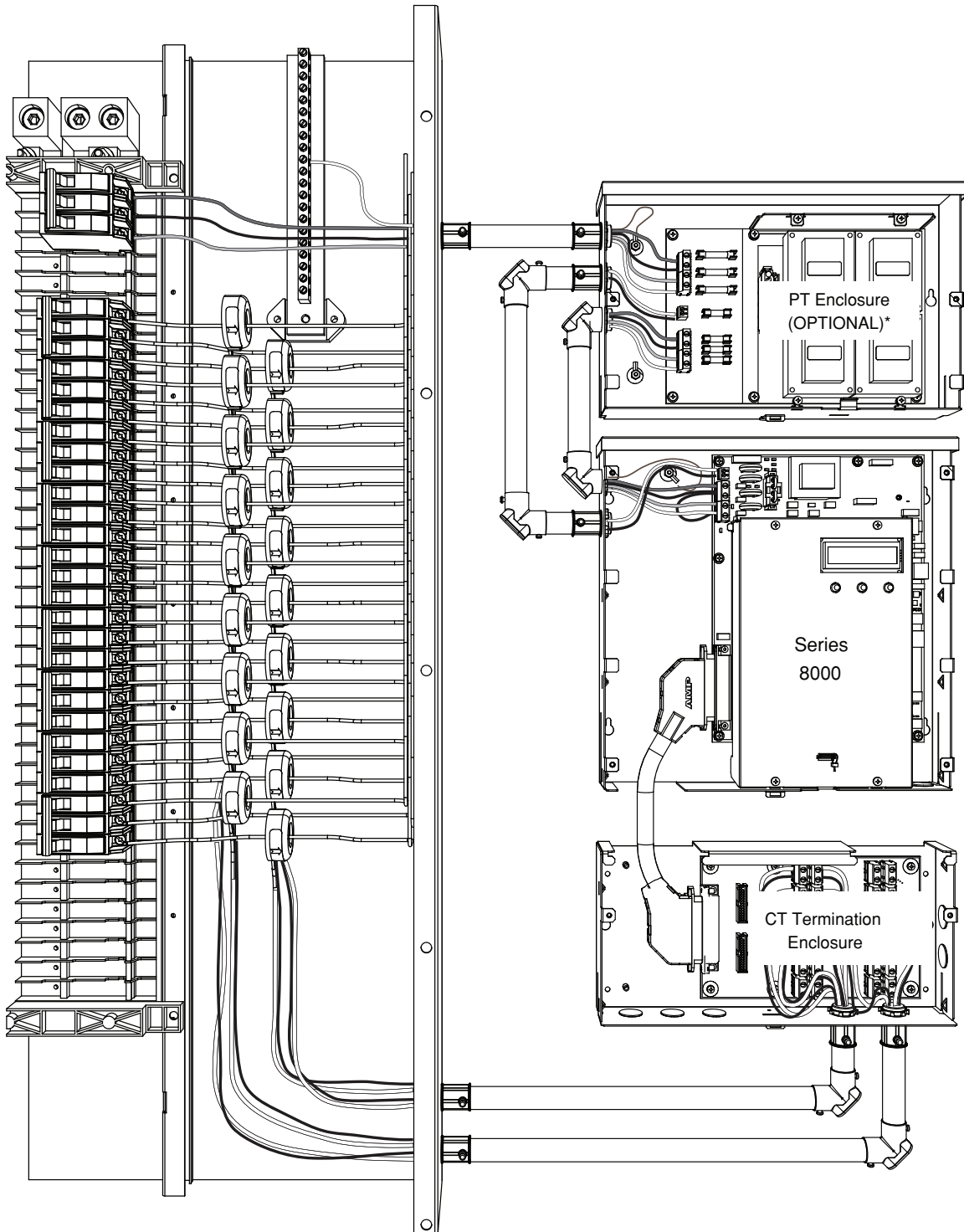

## SAFETY PRECAUTIONS

Carefully observe these safety instructions.

### **DANGER**

#### **HAZARD OF ELECTRICAL SHOCK, EXPLOSION, OR ARC FLASH**

- Apply appropriate personal protective equipment (PPF) and follow safe electrical work practices. See NFPA 70E.
- Only qualified electrical workers should install this equipment. Such work should be performed only after reading this entire set of instructions.
- This equipment must be accessible to authorized personnel only. Equipment must be installed in areas where access can be restricted.
- NEVER work alone.
- Before performing visual inspections, tests, or maintenance of this equipment, disconnect all sources of electrical power. Assume that all circuits are live until they have been completely de-energized, tested, and tagged. Pay particular attention to the design of the power system. Consider all sources of power, including the possibility of backfeeding.
- Turn off all power supplying the meter and the equipment in which it is installed before working on it.
- Always use a properly rated voltage sensing device to confirm that all power is off.
- Before closing all covers and doors, carefully inspect the work area for tools and objects that may have been left inside the equipment.
- Successful equipment operation requires proper handling, installation, and operation. Neglecting fundamental installation requirements can lead to personal injury as well as damage to electrical equipment or other property.
- NEVER bypass external fusing.
- NEVER short the secondary of a Potential Transformer (PT).
- NEVER short the secondary of a current transformer prior to disconnecting current input loads.

**Failure to follow these instructions will result in death or serious injury.**

#### **2.1 Electrical Safety Compliance**

- Use the unit only in accordance with the electrical power rating
- The unit is only to be installed by an electrician
- Initial installation of the unit must be inspected by the local electrical Inspection Authority
- Install the unit in compliance with the following local and national electrical codes:
  - Canada: Canadian Electrical Code, Part I, CSA C22.1
  - United States: National Fire Protection Association (NFPA) 70; US National Electrical Code
  - Elsewhere: International Electrotechnical Commission (IEC) 364, Part 1-7
- Ensure that the unit is properly earthed
- If the equipment is installed or used in a manner other than that specified in this document, it may void your warranty or impair the protection of the equipment

### 3. INSTALLATION

This section contains the following installation topics:

- "Pre-Installation"
- "Installation Procedures"
- "Start-Up Sequence"

#### 3.1 Pre-Installation

The pre-installation checklist and site planning must be performed before installing the equipment at the site.

##### 3.1.1 Pre-Installation Checklist

The installer must provide the following information, tools, and equipment before proceeding with the installation:

- Certified current transformers for metering
- An appropriate 15-Amp maximum circuit breaker or a fused disconnect
- Switch for the type of panel
- Current/voltage meter to test the phasing of panel
- RJ45 Ethernet patch cable
- 4-wire 14 AWG (1.63 mm<sup>2</sup>) cable for Three-Phase Wye connected circuits, or 3-wire 14 AWG (1.63 mm<sup>2</sup>) cable for a Single-Phase Wye connected circuits
- Small flat-head screwdriver
- Crimping tool
- #2 Phillips screwdriver
- 18 AWG butt splice connector
- Wire strippers
- Four 1-inch (25 mm) #8 mounting screws suitable for selected mounting surface

### 3.1.2 Site Planning

1. Determine the number of S8000 meters to be installed and ensure adequate space.
2. Determine the number of Modbus RTU or Ethernet drops required, and ensure they are installed before installing the S8000 meters.
3. Determine the number and types of meters or monitors required (Single-Phase, network, or Three-Phase).
4. Determine the model number and correct sense voltage based on the voltage label on the top right side of the unit.

### 3.1.3 Installation Procedures

This section provides information about activities that must be performed to install the Series 8000 meters in a Single-Phase 2-wire, Single-Phase 3-wire (network), or Three-Phase 4-wire application. The installation procedures must be performed in the following order:

1. "Mounting the S8000 Meters"
2. "Installing Potential Transformers for Three-Phase Service Greater Than 277V"
3. "Installing the Sense Voltage and Control Voltage Cables in Wye and Delta Services"
4. "Installing the Current Transformers"
5. "Connecting the Ethernet Communications"
6. "Connecting the Modbus RTU Communications"
7. "Start-Up Sequence"
8. "Completing the Installation Record"

### 3.1.4 Mounting the Series 8000 Meters

Figure 5 shows the general mounting layout for metering 120V/208V Wye services, and Figure 6 shows the general mounting layout for metering 347V/600V Wye services.

1. Mount the Series 8000 meter and the shorting block enclosure adjacent to the main circuit breaker box using the 1-inch (25-mm) #8 screws. If mounting the unit on a plasterboard surface, use cylinder plugs.
2. Remove the front cover from the meter by removing the four screws with a #2 Phillips screwdriver. Retain the cover and screws for later re-installation.
3. Mount the Series 8000 meter on the wall and secure it by inserting a screw in each mounting keyhole and tightening the screws.
4. Mount the CT Termination Enclosure on the wall as shown in Figure 5 and secure it by inserting a screw in each mounting keyhole and tightening the screws.

## INSTALLATION

In Figure 5, the meter is powered and takes its sense voltage directly from a breaker within the panel.

**Figure 5: 120V Mounting Layout, Dimensions and Clearances**

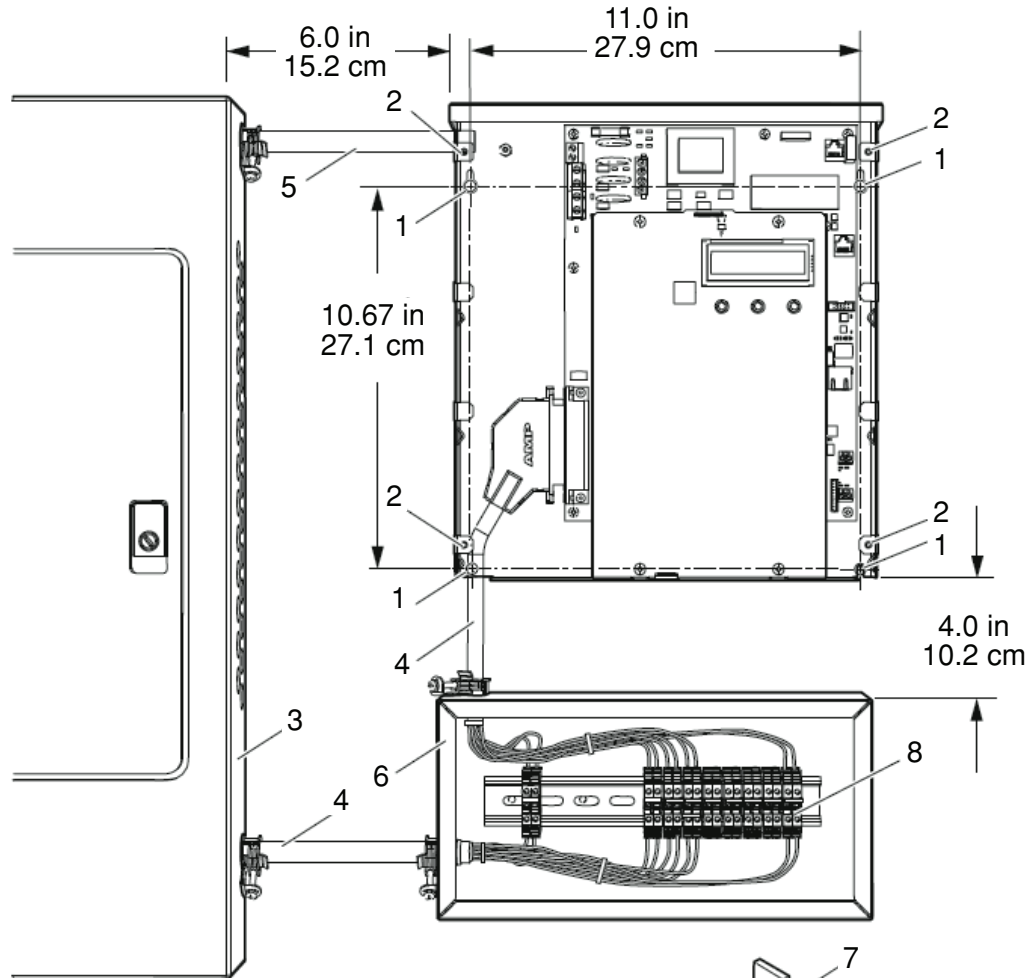

**Legend:**

- 1. Mounting keyhole
- 2. Cover screw location
- 3. Electrical distribution panel
- 4. CT conduit
- 5. Power conduit
- 6. CT Termination Enclosure
- 7. Shorting jumper
- 8. Shunting block
- 9. DIN rail

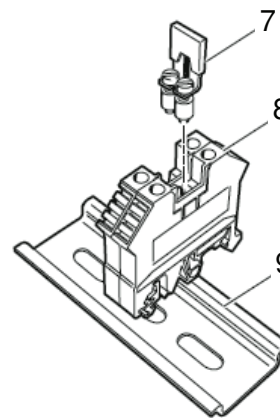



## INSTALLATION

Mount the potential transformer enclosure between the supply voltage and the Series 8000 meters as shown in Figure 7. Transformer configuration must be Y||Y (Wye/Wye).

In Figure 7, the meter is powered from the potential transformers that are fed from a breaker within the 347V/600V panel. The CT cable is connected to the shorting enclosure before connecting to the CTs in the panel.

**Figure 7: Typical 3-PH 347V Installation**

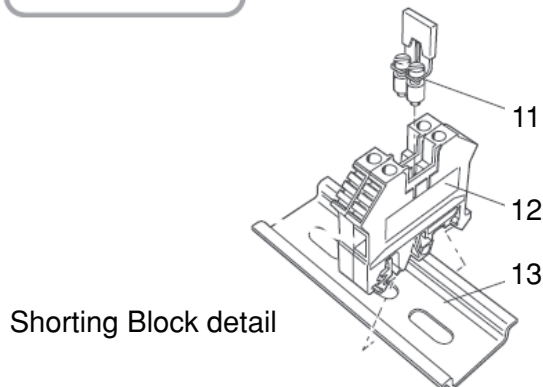
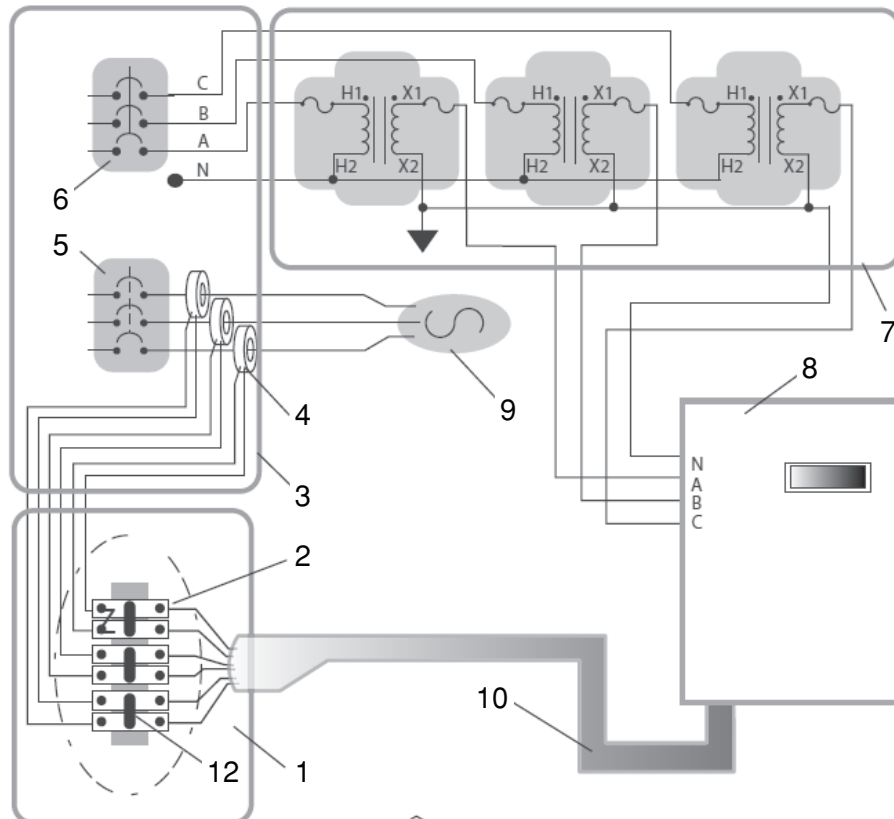

### Legend:

1. CT Termination Enclosure
2. Shorting block
3. Breaker Panel
4. Current Transformer
5. Load Breaker
6. Meter Breaker
7. Transformer Enclosure
8. PowerHawk Meter
9. Load
10. Cable
11. Shorting Jumper
12. Shorting Block
13. DIN Rail

### 3.1.6 Installing the Sense Voltage and Control Voltage Cables in Wye and Delta Services

The sense voltage (A, B, C, N) provides phase voltages for metering. The configuration depends on the type of service being metered:

- See "For a Single-Phase panel with the 120V variant of the meter."
- See "For a 120/208V Three-Phase Wye panel with the 120V variant of the meter."
- See "For a 240/416V Three-Phase Wye panel with the 230/240V variant of the meter."
- See "For a 277/480V Three-Phase Wye panel with the 120V variant of the meter."
- See "For a 347/600V or higher Three-Phase Wye panel with potential transformers with the 120V variant of the meter."
- See "For a Three-Phase Delta panel with the 120V variant of the meter."

The Series 8000 meters are shipped from the factory with a control voltage jumper that can be used to connect the control voltage input and the sense voltage inputs to provide control voltage to the unit. The following procedures explain how to connect the sense voltage inputs for each of the service types.

For a Single-Phase panel, use a 3-wire (red, black, white), 14 AWG (1.63 mm<sup>2</sup>), 90°C (194°F) cable. For a Three-Phase panel, use a 4-wire (red, black, blue, white), 14 AWG (1.63 mm<sup>2</sup>), 90°C (194°F) cable. For a Delta service, use a 3-wire (red, black, blue), 14 AWG (1.63 mm<sup>2</sup>), 90°C (194°F) cable. Metallic, flexible armored cable (BX cable) is recommended for commercial installations as shown in Figure 7 on page 14.

The Series 8000 meters must be connected to the sense voltage and control voltage through a properly rated disconnect that disconnects all line and neutral wires, so it can be powered down. The disconnect must be located within easy reach of the meter operator, and must be labeled as such. Opening the disconnect or breaker is the disconnect device. For multiple Series 8000 meter installations, the same disconnect can be used to power all meters, and must be labeled for all meters it supplies power to. The disconnect device must meet IEC 60947-1, IEC 60947-3 and/or comply with the local electrical code.

## INSTALLATION

Carefully observe these safety instructions.



### DANGER

#### HAZARD OF ELECTRICAL SHOCK, EXPLOSION, OR ARC FLASH

- Apply appropriate personal protective equipment (PPF) and follow safe electrical work practices. See NFPA 70E.
- This equipment must only be installed and serviced by an electrician.
- Turn off all power supplying this equipment before working on or inside this equipment.
- Always use a properly rated voltage sensing device to confirm power is off.
- Replace all devices, doors and covers before turning on power to this equipment.
- The meters must be connected to the sense voltage and control voltage through a properly rated voltage disconnect (not shown in the wiring diagrams).

**Failure to follow these instructions will result in death or serious injury.**

***NOTE: If the circuit breaker panel does not designate Phase A, Phase B and Phase C feeds, make your own designation and use it for the rest of the installation.***

1. Before connecting the sense voltages, turn off the power to the circuit being connected.
2. Always use a properly rated voltage sensing device to confirm power is off.
3. Connect the sense voltages phase A, B, C, and N leads from the voltage disconnect to the meter as described in Figure 6 on page 13 and Figure 7 on page 14.

***NOTE: The phase wiring sequence A, B, C between the Series 8000 meter and the panel must match or the measurement readings will be wrong.***

4. If more than one meter is being installed, repeat this procedure for each additional meter.

## INSTALLATION

For a Single-Phase Panel with the 120V variant of the meter:

- Connect meter Terminal A to the voltage disconnect Phase A (red wire)
- Connect meter Terminal B to the voltage disconnect Phase B (black wire)
- Connect meter neutral terminal to neutral bar in the voltage disconnect panel (white wire)
- Connect earth wire to earth post using lug provided
- Meter Terminal C is not connected
- Install power supply shorting jumpers (see Figure 8)

The Series 8000 meters are rated for direct input of 120V to 277V 60Hz phase potential. When metering services greater than 120V, the meter is powered from a separate 120V instrument transformer.

**Figure 8: Series 8000 Meter in a 120/240V Single-Phase Connection**

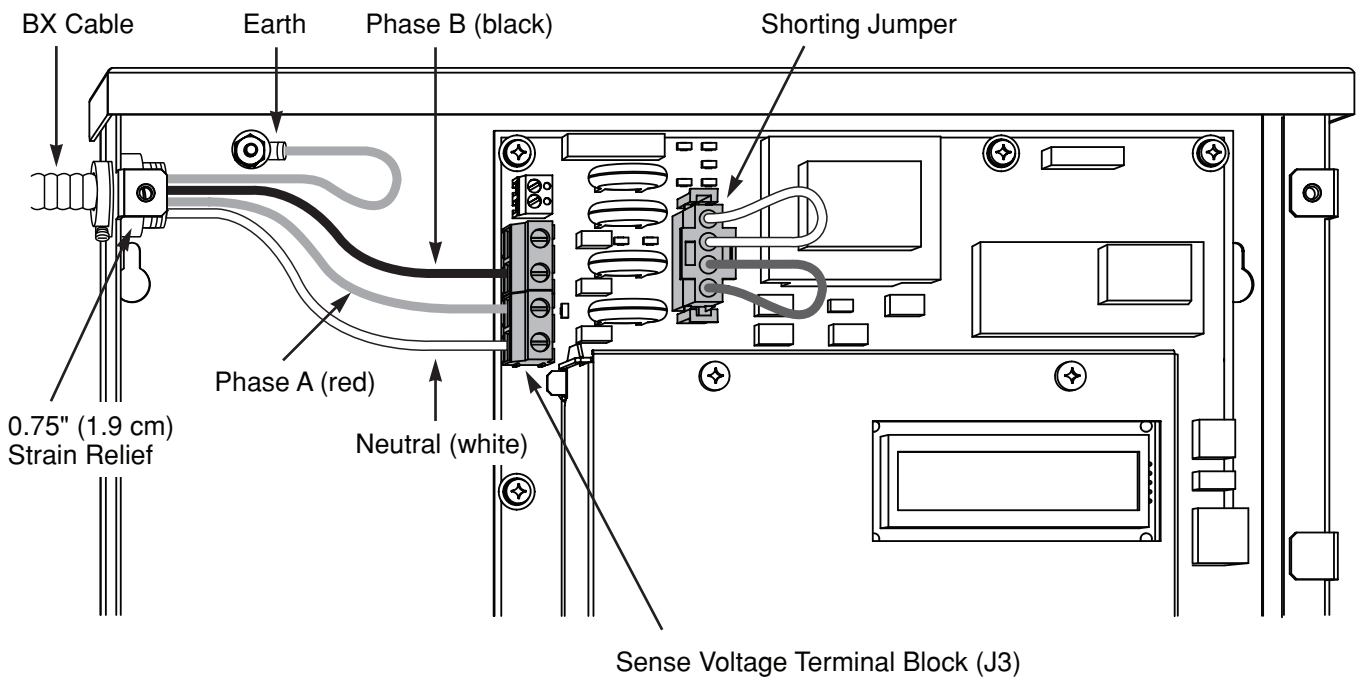

## INSTALLATION

For a 120/208V Three-Phase Wye panel with the 120V variant of the meter:

- Connect meter Terminal A to the voltage disconnect Phase A (red wire)
- Connect meter Terminal B to the voltage disconnect Phase B (black wire)
- Connect meter Terminal C to the voltage disconnect Phase C (blue wire)
- Connect meter neutral terminal to neutral bar in the voltage disconnect panel (white wire)
- Connect earth wire to earth post using lug provided
- Install power supply shorting jumpers (see Figure 9)
- For a 120/208V Three-Phase Wye panel version with no shorting blocks (see Figure 10)

**Figure 9: S8000 Meter 120/208V Three-Phase Wye Service Connection**

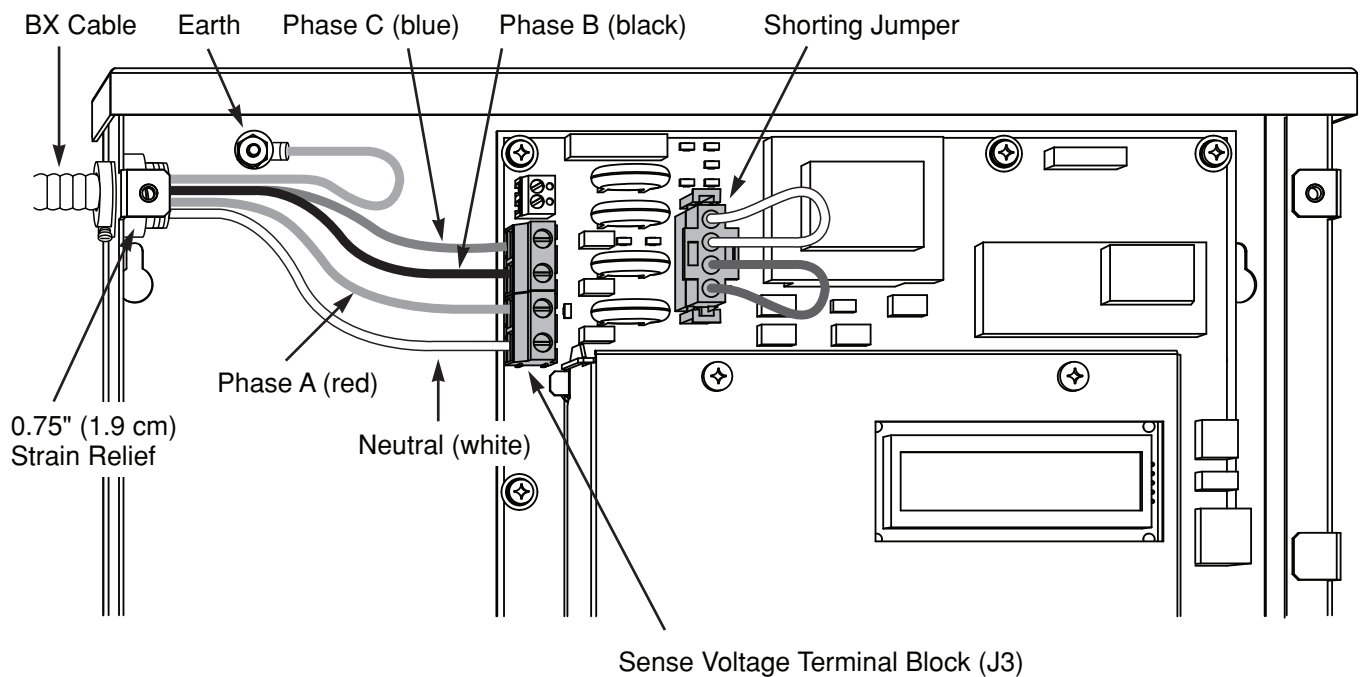
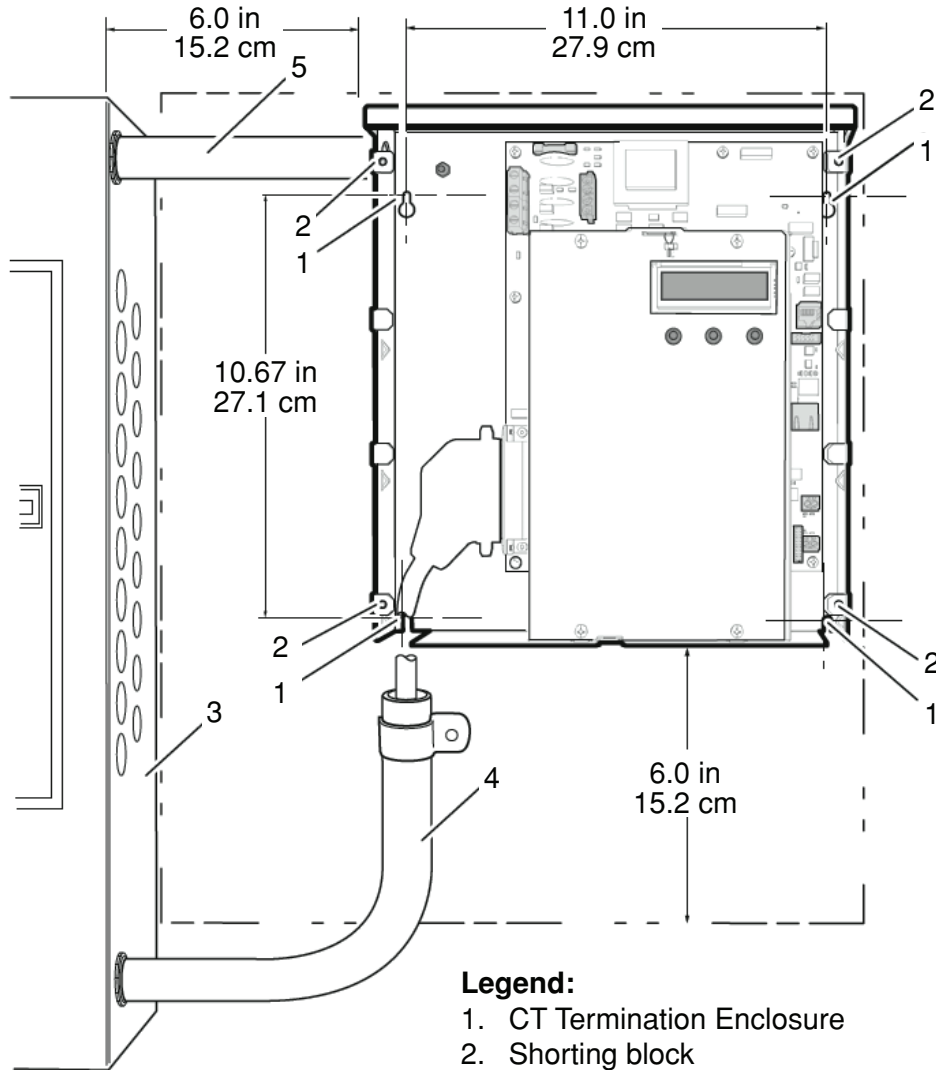

Figure 10: For a 120/208V Three-Phase Wye Panel Version with no Shorting Blocks



**Legend:**

- 1. CT Termination Enclosure
- 2. Shorting block
- 3. Breaker Panel
- 4. Current Transformer
- 5. Load Breaker
- 6. Meter Breaker
- 7. Transformer Enclosure
- 8. PowerHawk Meter
- 9. Load
- 10. Cable
- 11. Shorting Jumper
- 12. Shorting Block
- 13. DIN Rail

## INSTALLATION

For a 277/480V Three-Phase Wye panel with the 120V variant of the meter:

- Connect meter Terminal A to the voltage disconnect Phase A (red wire)
- Connect meter Terminal B to the voltage disconnect Phase B (black wire)
- Connect meter Terminal C to the voltage disconnect Phase C (blue wire)
- Connect meter neutral terminal to neutral bar in the voltage disconnect panel (white wire)
- Connect earth wire to earth post using lug provided
- From the auxiliary power transformer, connect 120V auxiliary power to AUX A and AUX N on the meter (see Figure 11)

**Figure 11: S8000 Meter 277/480V Three-Phase Wye Service Connection**

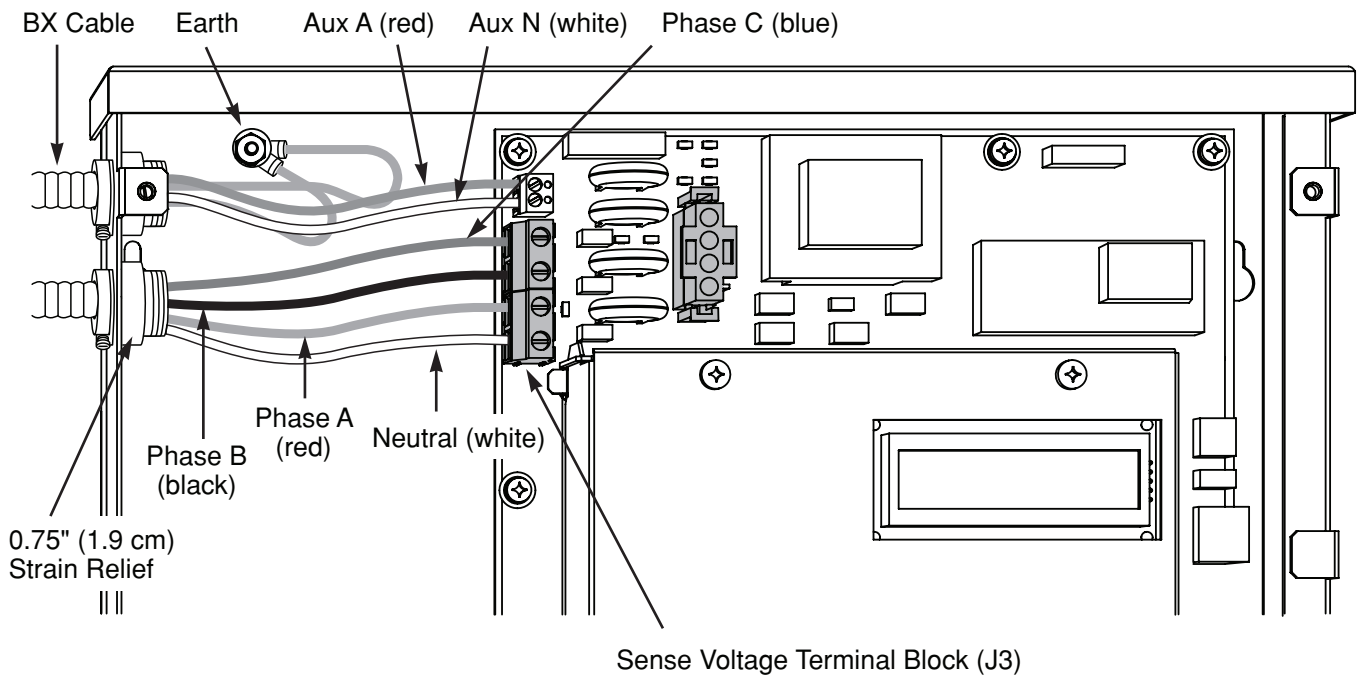

## INSTALLATION

For a 277V/480V Three-Phase Wye Service panel with the 277V variant of the meter:

- Connect the sense voltage Phase A (red wire) to the step down transformer Terminal A
- Connect sense voltage B to the sense voltage connector J3 Phase B (black wire)
- Connect sense voltage C to the sense voltage connector J3 Phase C (blue wire)
- Connect sense voltage N to step down transformer Terminal N (white wire)
- Connect the earth wire to earth post using lug provided
- Check the 277V Input box on the UL label on the Series 8000 chassis (see figure 12)

**Figure 12: 277/480V Wye Wiring**

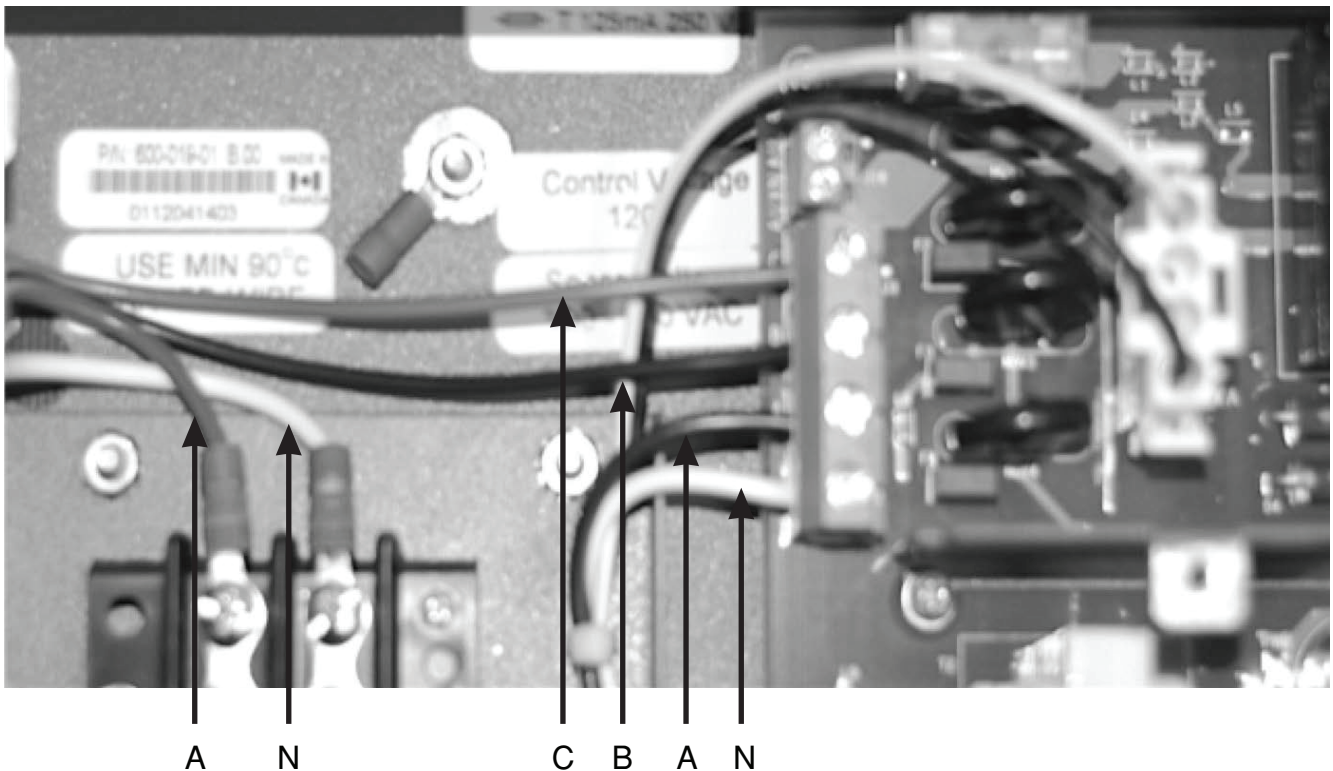

## INSTALLATION

For a 347/600V or higher 3PH Wye panel with potential transformers with the 120V variant of the meter:

- Connect meter terminal A to the voltage disconnect phase A (red wire)
- Connect meter terminal B to the voltage disconnect phase B (black wire)
- Connect meter terminal C to the voltage disconnect phase C (blue wire)
- Connect meter neutral terminal to neutral bar in the voltage disconnect panel (white wire)
- Connect earth wire to earth post using lug provided
- Install power supply shorting jumpers (see Figure 13)

NOTE: For the wiring of the potential transformers, see Figure 4.

**Figure 13: Series 8000 Meter 347/600V or higher Three-Phase Wye Service with Potential Transformers Connection**

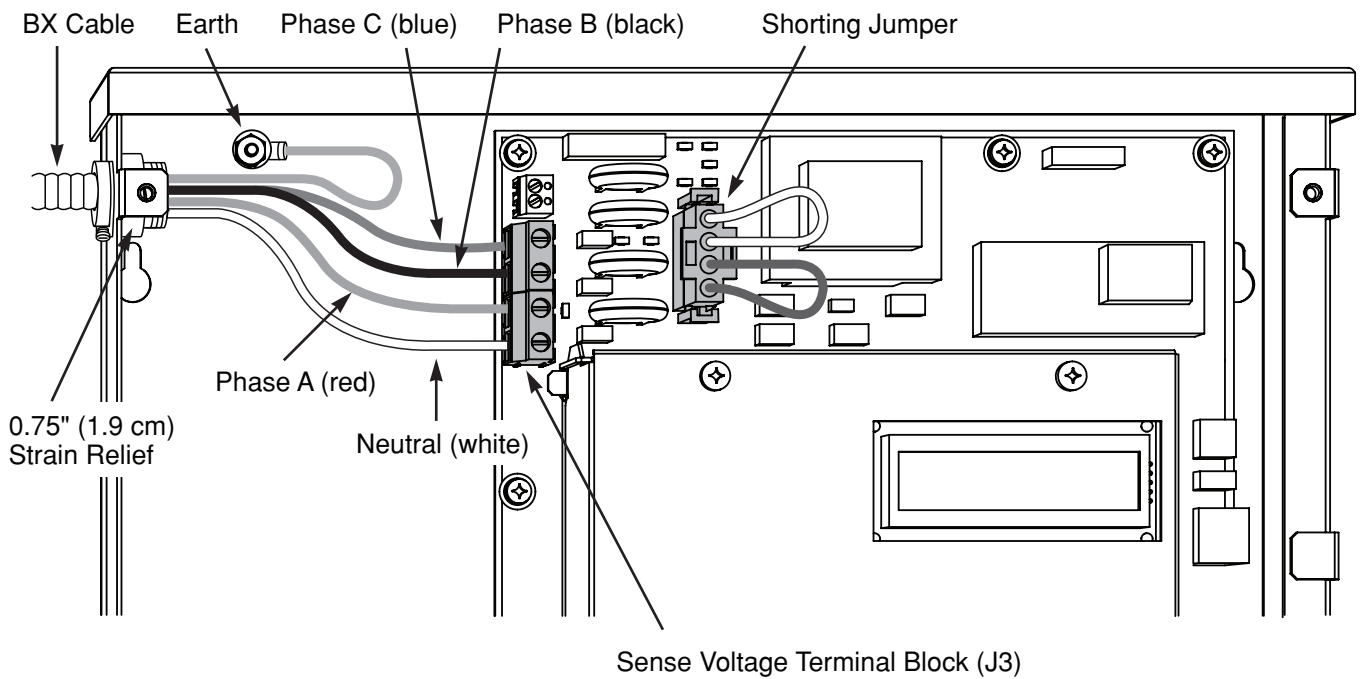

## INSTALLATION

### Delta Service Metering

To use the S8000 meter in a Delta service, the line-to-line voltage from the Delta service must be reduced to 120V line-to-line using appropriate potential transformers. Metering a Delta service requires only two potential transformers, and only two CTs for Phase A and C. Using the Phase B CT is optional.

For a 3PH Delta panel with the 120V variant of the meter:

- Connect meter Terminal A to the voltage disconnect Phase A (red wire)
- Connect meter Terminal C to the voltage disconnect Phase C (blue wire)
- Connect meter neutral terminal to meter Terminal B (black wire)
- Connect earth wire to earth post using lug provided
- Install power supply shorting jumpers (see Figure 14)

**Figure 14: Series 8000 Meter 3PH Delta Service Connection**

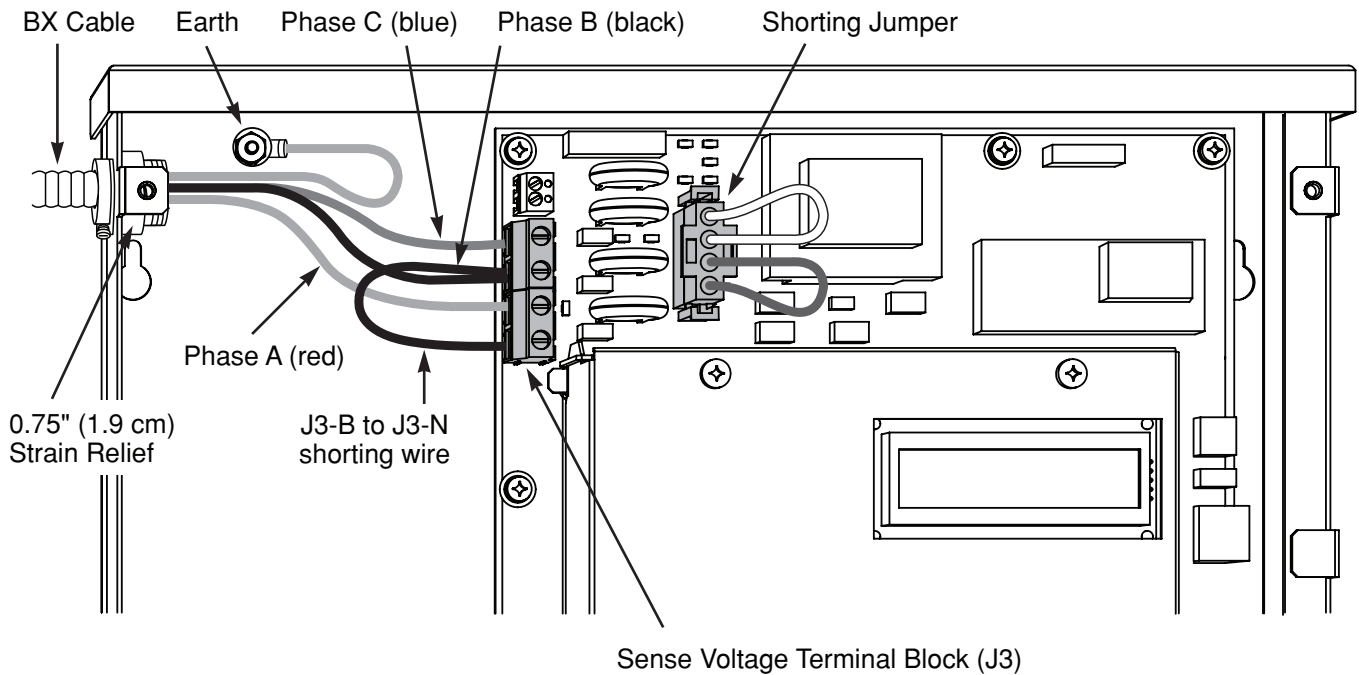

# INSTALLING CURRENT TRANSFORMERS

## 1. INSTALLING CURRENT TRANSFORMERS

Both models of Series 8000 meter use current transformers (CTs) with different secondary outputs. All Series 8000 models S8UTS, 277TS, S8UWH, 277WH and S8120 meter variants uses solid-core 100mA CTs and is typically used where accuracy is important and long secondary CT wiring is required (up to 300 feet [91.44 meters]).

Current transformers connect to the Series 8000 meters through the Wiring Harness version or the Terminal Strip version utilizing the CT Termination Enclosure. In the tables located below the CT wire pairs and the cable color scheme for each meter point are shown. You can also find this information on the inside of the meter's outer cover. Each CT has an X1 (positive) and X2 (neutral) wire pair and uses butt-splice connectors to attach the CT to a specific meter wire pair. The direction of the energy flow is indicated on the CT.

**Table 1: S8UTS-083; 277TS-083  
S8UWH-083, 277WH-083**

Cable 1		
Meter Point ID	CT X1 Color	CT X2 Color
P1-1	Black	Green
P1-2	Black	White
P1-3	Black	Red
P2-1	Red	Green
P2-2	Red	White
P2-3	Black	Orange
P3-1	Black	Brown
P3-2	Black	Yellow
3P-3	Black	Blue
P4-1	Green	Yellow
P4-2	Green	Blue
P4-3	Green	White
P5-1	Blue	White
P5-2	Green	Orange
P5-3	Green	Brown
P6-1	Blue	Yellow
P6-2	Brown	White
P6-3	Orange	White
P7-1	Red	Orange
P7-2	Red	Yellow
P7-3	Red	Brown
P8-1	Blue	Orange
P8-2	Yellow	White
P8-3	Blue	Brown

**Table 2: S8120-122, S8UTS-122  
S8UWH-122, 277TS-122, 277WH-122**

Cable 1		
Meter Point ID	CT X1 Color	CT X2 Color
P1-1	Black	Green
P1-2	Black	White
P2-1	Black	Red
P2-2	Red	Green
P3-1	Red	White
P3-2	Black	Orange
P4-1	Black	Brown
P4-2	Black	Yellow
P5-1	Black	Blue
P5-2	Green	Yellow
P6-1	Green	Blue
P6-2	Green	White
P7-1	Blue	White
P7-2	Green	Orange
P8-1	Green	Brown
P8-2	Blue	Yellow
P9-1	Brown	White
P9-2	Orange	White
P10-1	Red	Orange
P10-2	Red	Yellow
P11-1	Red	Brown
P11-2	Blue	Orange
P12-1	Yellow	White
P12-2	Blue	Brown

**Table 3: S8UTS-241, S8UWH-241,  
277TS-241, 277WH-241**

Cable 1		
Meter Point ID	CT X1 Color	CT X2 Color
P1-1	Black	Green
P2-1	Black	White
P3-1	Black	Red
P4-1	Red	Green
P5-1	Red	White
P6-1	Black	Orange
P7-1	Black	Brown
P8-1	Black	Yellow
P9-1	Black	Blue
P10-1	Green	Yellow
P11-1	Green	Blue
P12-1	Green	White
P13-1	Blue	White
P14-1	Green	Orange
P15-1	Green	Brown
P16-1	Blue	Yellow
P17-1	Brown	White
P18-1	Orange	White
P19-1	Red	Orange
P20-1	Red	Yellow
P21-1	Red	Brown
P22-1	Blue	Orange
P23-1	Yellow	White
P24-1	Blue	Brown

# INSTALLING CURRENT TRANSFORMERS

**Table 4: S8120-032**

Cable 1		
Meter Point ID	CT X1 Color	CT X2 Color
P1-1	Black	Green
P1-2	Black	White
P2-1	Black	Red
P2-2	Red	Green
P3-1	Red	White
P3-2	Black	Orange

**Table 5: S8120-062**

Cable 1		
Meter Point ID	CT X1 Color	CT X2 Color
P1-1	Black	Green
P1-2	Black	White
P2-1	Black	Red
P2-2	Red	Green
P3-1	Red	White
P3-2	Black	Orange
P4-1	Black	Brown
P4-2	Black	Yellow
P5-1	Black	Blue
P5-2	Green	Yellow
P6-1	Green	Blue
P6-2	Green	White

**Table 6: S8120-092**

Cable 1		
Meter Point ID	CT X1 Color	CT X2 Color
P1-1	Black	Green
P1-2	Black	White
P2-1	Black	Red
P2-2	Red	Green
P3-1	Red	White
P3-2	Black	Orange
P4-1	Black	Brown
P4-2	Black	Yellow
P5-1	Black	Blue
P5-2	Green	Yellow
P6-1	Green	Blue
P6-2	Green	White
P7-1	Blue	White
P7-2	Green	Orange
P8-1	Green	Brown
P8-2	Blue	Yellow
P9-1	Brown	White
P9-2	Orange	White

### 5. CONNECTING THE ETHERNET COMMUNICATIONS

When the Ethernet port is used to report data, an RJ45 patch cable is required to connect the Ethernet port to the local Ethernet network.

1. Route the cable through the slot in the Series 8000 meter enclosure.
2. If the local network automatically assigns IP addresses through a DHCP server, the Series 8000 meter will be able to report using its factory default IP settings. If the local network is configured for static IP addresses, refer to the Series 8000 meter Configuration Guide for instructions on how to configure default static IP addresses.

## CONNECTING THE MODBUS RTU COMMUNICATIONS

### 6. CONNECTING THE MODBUS RTU COMMUNICATIONS

If the Modbus port is used to report data, an RS422/RS485 serial cable is required to connect the Modbus RTU port to the local Modbus network.

1. Route the cable through the slot in the Series 8000 meter enclosure.
2. Depending on the position of the Series 8000 meter in the Modbus network as shown in Figure 15, set the DIP switches as follows in the below table:

DIP Switch Settings				
Series 8000 Meters Location	S1	S2	S3	S4
Head end	On	Off	Off	Off
Intermediate	Off	Off	Off	Off
Tail end	On	On	On	Off

3. Refer to the Series 8000 meter Configuration Guide for instructions on how to configure the baud rate, parity settings, and Modbus base address for the RS485 RTU communications.

**Figure 15: Modbus Wiring Diagram**

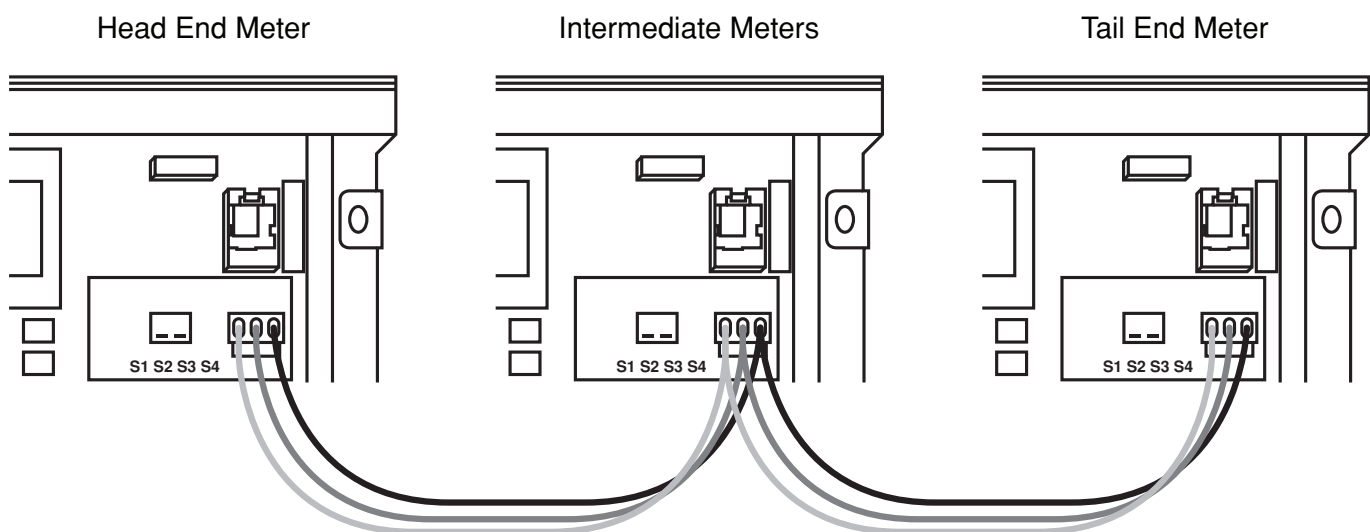

### 7. START-UP SEQUENCE

Use the following procedure to start up the Series 8000 meter.

1. Ensure that all CT and sense voltage wiring is securely installed.
2. Remove all tools from the work area.
3. Re-install all cover plates and equipment covers.
4. Power up the meter. The LCD on the front panel of the meter indicates the operating status of the unit as follows:
  - a. Initial power up message "LEVITON"
  - b. After the internal configuration is complete, the display shows default information for the first meter.

#### 7.1 Manually Testing Communications

This procedure clears the meter memory, manually tests the communications from the Series 8000 meter, and updates the meter clock. To force the meter to send data, follow these steps:

1. Press and hold the Display button for 5 to 7 seconds until the diagnostics mode is displayed, then release.
2. For communicating via Ethernet, press the Display button until "Local IP Address" appears on the display.
  - a. If the IP address is 192.168.0.9, the meter has not found a DHCP server. As a result, the meter will use its default IP configuration and may not be able to report. See the Series 8000 meter Configuration Guide for instructions on how to program default IP addresses.
  - b. If the IP address is not 192.168.0.9, the meter has acquired an IP address from the local network, and will be able to report data and synchronize time.
3. Press the Display button until the "Send" command appears on the display.
4. Press the center or the right arrow button to manually force the Series 8000 meter to report metering data using the Ethernet connection. This clears data from the Series 8000 meter memory, and ensures the time is set correctly.

### 8. PULSE INPUTS

There are two Pulse In terminal blocks in the Series 8000 meter, as shown in Figure 2. Each terminal block has a negative terminal pin on the right and a positive terminal pin on the left. The pulse inputs are compatible with both dry and solid-state form A contacts, 10 Hz (maximum), 20 ms pulse width (minimum). The inputs are not polarity-sensitive to dry relay contacts. When the pulsing device provides solid-state form A outputs, the negative terminal from the source device must be connected to the negative terminal of the Series 8000 meter pulse in terminal block.

### 9. DISPLAY NAVIGATION

The Series 8000 meter has three buttons to control the information presented on the LCD. The display has a normal and a diagnostics mode. The Series 8000 meter starts in normal mode, and enters diagnostics mode when the Display button is pressed and held for 5 seconds. To adjust the contrast, hold down the Display button, and use the right and left arrow buttons to increase and decrease the contrast respectively.

#### 9.1 Normal Mode

In Normal mode, the Display button scrolls through the information for each meter. The left and right arrow buttons select the previous or next meter points respectively. The following information is available:

- Real Energy Delivered kWh D
- Real Energy Received kWh R
- Real Power Watts
- Reactive Energy Delivered KVarhD
- Reactive Energy Received KVarhR
- Reactive Power Var

In Normal mode, the right and left arrow buttons scroll the display from meter points 1 to 8, 1 to 12, or 1 to 24, depending on your configuration.

#### 9.2 Diagnostics Mode

Diagnostics mode is accessed by pressing and holding the Display button for 5 seconds.

In Diagnostics mode, pressing the Display button will scroll through the following additional information:

- Send data command
- CT Primary value and Real Power Watts per phase
- Voltage per phase
- Local IP address
- Reset factory default IP address command
- Date and time (UTC)

In Diagnostics mode, the right and left arrow buttons scroll the display from meter 1 through N. When the local IP address is shown on the LCD, use the right and left arrow buttons to scroll through the following information:

- Remote host server IP address
- Time server IP address
- Default IP address
- Default NetMask
- Default gateway
- PPP user name
- Phone number
- AT command string
- Alternate phone number
- Unit serial number
- Firmware build number
- Ethernet port MAC address
- Firmware revision
- Potential transformer ratio

### 10. CONFIGURATION TOOL INSTALLATION

- Type “Series 8000 Meters” in the search bar
- Click on your specific Series 8000 model
- Click on the “Software - Series 8000 Configuration Tool” link

Unzip and run the install program provided with the Leviton Configuration Tool application on a Windows laptop or desktop computer.

#### 10.1 Network and Meter Setup

Power up the S8000 from the aux. power connector.

Connect one or more S8000 meters to the same network, and the same subnet as the computer that will be running the S8000 Configuration Tool.

Start the Configuration Tool from the windows start menu or the shortcut on the desktop.

Login as:

- UserName: Leviton
- Password: S8000

The screenshot displays the S8000 Configuration Tool interface. The main window has a menu bar with 'Unit' and 'Help'. Below the menu bar are tabs for 'Unit Field Configuration', 'Manufacturing', 'Meter Points (Circuits)', and 'Pulse Probes'. The 'Unit Field Configuration' tab is active, showing fields for 'Current IP Address', 'MAC Address', and 'Revision'. To the right, there's a section for 'Main Meter - 120V - WYE' with a 'PT Ratio' of 1.000. Below these are 'Default IP Configuration' fields for 'IP Address', 'Network', 'Gateway', 'DNS Primary', and 'DNS Secondary', along with a 'DHCP Enabled' checkbox. A 'Modem' section is also visible. A 'Report' section at the bottom left includes 'Recording Intervals in Minutes' (set to 60), 'Demand Interval Setup' (with 'Block Demand' selected), and 'Demand Interval in Minutes'. A 'Download Directory' field is present. On the right side, there are sections for 'FTP Login' (User Name, Password), 'PPP Login' (User Name, Password), and 'NTP Host (Time Server)' (IP Address). A 'Unit Type: 6312-120V' is displayed at the bottom right. A 'S8000 Configuration Tool Login' dialog box is overlaid on top, with 'User Name' set to 'Leviton' and 'Password' masked with asterisks. It has 'Ok' and 'Cancel' buttons.

# CONFIGURATION TOOL INSTALLATION

## 10.2 Connecting to the S8000 Meter

Using the “Unit” drop down on the applications banner select the list function. This will cause the application to search the local subnet for S8000 meters to connect to.

After a few moments the meters found will be listed in a table.

Unit Discovery											
	IP Address	Model	Name	MAC Address	Firmware	Build	Serial Number	Programmable?	SFG1	SFG2	Status
	192.168.111.47	9320									Found
	192.168.111.30	6320	3P-10								Network Error
	192.168.111.58	6320	2P-20	0090C2C85C	1.12	1075	0248050022	Prog On			Found
	192.168.111.117	6312-102V-2P-24	6312-102V-2...	0021B6002719	1.51	1127	0112041655	Prog On	5	1	Found
	192.168.111.137	6312-102V-2P-24	6312-102V-2...	0021B600210F	1.46	1105	0208410601	Prog On	5	0	Found
	192.168.111.134	6303-102V-2P-03	6303-102V-2...	0021B60023...	1.46	1105	0211020601	Prog On	13	1	Found
	192.168.111.81	EM4888016-2p-24	EM4888016-2...	0021B6002A...	1.50	1126	0111481196	Prog On	5	1	Found
	192.168.111.133	EM488026-3P-08	EM488026-3...	0021B60000...	1.40	1065	0211030302	Prog On	6	1	Found
	192.168.111.160	E488016-3P-08	E488016-3P-08	0021B6002929	1.46	1105	0210470225	Prog On	5	0	Found
	192.168.111.169	EM408036-3P-08	EM408036-3...	0021B60029C3	1.46	1105	0212450289	Prog On	5	1	Found
	192.168.111.73	6412-120V-3P-08	6412-120V-3...	0021B600002E	1.46	1105	0000000000	Prog On	8	1	Found
	192.168.111.126	6212-230V-3P-08	6212-230V-3...	0021B6002C...	1.51	1127	0113170984	Prog On	4	1	Found
	192.168.111.68	8124-277V-3P-08	8124-277V-3...	0021B6002A...	1.47	1121	0212060212	Prog On	18	1	Found
	192.168.111.131	6312-102V-2P-24	6312-102V-2...	0021B600043A	1.51	1127	0209200249	Prog On	5	0	Found
	192.168.111.123	6312-102V-3P-08	6312-102V-3...	0021B6001582	1.51	1127	0210160924	Prog On	5	0	Found

Interface: Local Area Connection 3    Refresh     Clear ARP for discovery     Load Config    Specify    Cancel    Ok

Select the S8000 to be programmed and click OK.

WEB VERSION

## CONFIGURATION TOOL INSTALLATION

After a few moments the Configuration Tool will retrieve the existing programming from the meter and display the following screen.

The screenshot displays the 'S8000 Configuration Tool' window. The title bar includes 'Unit' and 'Help' menus. The main area is divided into several sections:

- Unit Field Configuration:** Includes fields for 'Current IP Address' (192.168.111.68), 'MAC Address' (0021B6002AAB), and 'Revision'.
- Default IP Configuration:** Includes fields for 'IP Address' (192.168.0.9), 'Network' (255.255.255.0), 'Gateway' (192.168.0.1), 'DNS Primary' (192.168.0.1), and 'DNS Secondary' (192.168.0.1). A checkbox for 'DHCP Enabled' is present.
- Main Meter - 120V - WYE:** Includes a 'PT Ratio' field (1.000).
- Modem:** Includes fields for 'Phone #' (631-228-9329), 'Alternate Phone #' (1-631-228-9329), 'AT String' (AT X3 -STE=7), and a 'Wait for Dial Tone' checkbox.
- Host Server:** Includes fields for 'IP Address' (206.191.53.50), 'Upload Directory' (download), and 'Download Directory' (upload).
- FTP Login:** Includes fields for 'User Name' (triacta) and 'Password' (Mxtt3rdf).
- PPP Login:** Includes fields for 'User Name' (pwrhwk@magma.ca) and 'Password' (JvV+p6).
- NTP Host (Time Server):** Includes a field for 'IP Address' (206.191.53.50).

At the bottom, a status bar shows 'File loaded successfully!' on the left and 'Unit Type: 6312-120V' on the right. A 'Report' section is also visible, containing sub-sections for 'Intervals', 'Types', 'Reporting Schedule', 'Calculations & Format', 'BACnet', and 'Comms'. The 'Intervals' sub-section shows 'Recording Intervals in Minutes' set to 60, 'Demand Interval Setup' with 'Block Demand' selected, and 'Demand Interval in Minutes' set to 60.

**11. REGULATORY COMPLIANCE**

The Series 8000 meter must be installed by a certified electrician with knowledge of local safety regulations. Initial installation of the unit, and any subsequent modification to the unit, must be inspected by the local electrical safety authority. The Series 8000 meter complies with the standards listed in Table 3.

**Table 3: Regulatory Compliance**

<b>Discipline</b>	<b>Regulatory and Industry Standard</b>
Safety	UL certified to IEC/EA/UL/CSA 61010-1 2nd Edition CSA-C22.2 No. 61010-1-04
Emissions (EMC)	FCC Part 15 Class B, ICES-003 EN55022, IEC 6100-4-5
Surge power/telephone lines	ANSI/TIA968-A: 2002

## WARRANTY

### FOR CANADA ONLY

For warranty information and/or product returns, residents of Canada should contact **Leviton in writing** or by telephone.

#### LIMITED 2 YEAR WARRANTY AND EXCLUSIONS

Leviton warrants to the original consumer purchaser and not for the benefit of anyone else that this product at the time of its sale by Leviton is free of defects in materials and workmanship under normal and proper use for two years from the purchase date. Leviton's only obligation is to correct such defects by repair or replacement, at its option. This warranty excludes and there is disclaimed liability for labor for removal of this product or reinstallation. This warranty is void if this product is installed improperly or in an improper environment, overloaded, misused, opened, abused, or altered in any manner, or is not used under normal operating conditions or not in accordance with any labels or instructions. **There are no other or implied warranties of any kind, including merchantability and fitness for a particular purpose**, but if any implied warranty is required by the applicable jurisdiction, the duration of any such implied warranty, including merchantability and fitness for a particular purpose, is limited to two years.

**Leviton is not liable for incidental, indirect, special, or consequential damages, including without limitation, damage to, or loss of use of, any equipment, lost sales or profits or delay or failure to perform this warranty obligation.** The remedies provided herein are the exclusive remedies under this warranty whether based on contract, tort or otherwise.

**Trademark Disclaimer:** Use herein of third party trademarks, service marks, trade names, brand names and/or product names are for informational purposes only, are/may be the trademarks of their respective owners; such use is not meant to imply affiliation, sponsorship, or endorsement.

Specifications and Price Subject to Change at any time without notice