

R5408

REED INSTRUMENTS

Resistance Decade Box

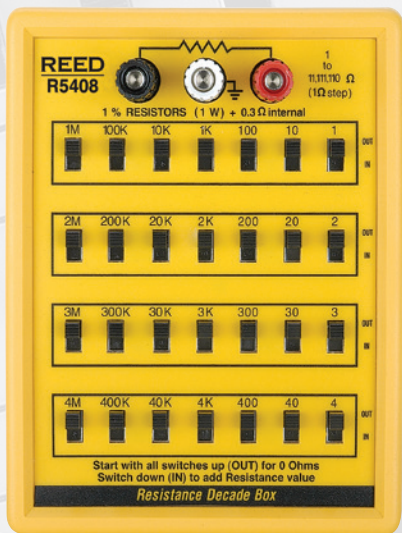

Instruction Manual

Table of Contents

Introduction	3
Product Quality.....	3
Safety	3
Features.....	3
Specifications.....	4
Instrument Description	4
Operating Instructions.....	5-7
<i>Terminal Connections</i>	5
<i>Resistance Value Setting (Range Selection)</i>	5-6
<i>Important Operating Limits</i>	6
<i>Power Dissipation Note</i>	6
<i>Calibration Verification (Testing)</i>	6-7
Product Care	7
Product Warranty	8
Product Disposal and Recycling	8
Product Support.....	8

Introduction

Thank you for purchasing your REED R5408 Resistance Decade Box. Please read the following instructions carefully before using your instrument. By following the steps outlined in this manual your meter will provide years of reliable service.

Product Quality

This product has been manufactured in an ISO9001 facility and has been calibrated during the manufacturing process to meet the stated product specifications. If a certificate of calibration is required please contact the nearest authorized REED distributor or authorized Service Center. Please note an additional fee for this service will apply.

Safety

Never attempt to repair or modify your instrument. Dismantling your product, other than for the purpose of replacing batteries, may cause damage that will not be covered under the manufacturer's warranty. Servicing should only be provided by an authorized service center.

Features

- 1% Resistance substitution from 1 to 11,111,110 Ω
- Excellent for circuit development
- 3 binding posts permit isolated substitutions
- 7 decade ranges of resistance
- Durable construction

Specifications

Range:	1 to 11,111,110 Ω , 7 ranges
Resolution:	1 Ω increments
Accuracy:	$\pm 1\%$ of reading
Operating Temperature:	32 to 122°F (0 to 50°C)
Dimensions:	4.6 x 5.8 x 2.0" (117 x 147 x 51mm)
Weight:	0.73lb (330g)

Instrument Description

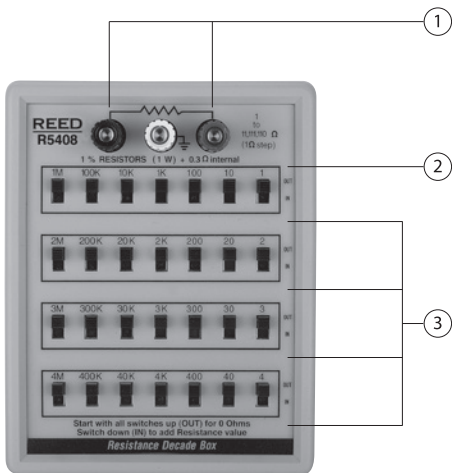

1. Resistance Output Terminal
2. Ground Terminal
3. Range Select Switch

Operating Instructions

Terminal Connections

The R5408 terminals (binding posts) permit connections using several standard methods:

- **Banana Plugs:** A banana plug may be inserted directly into the top of the posts.
- **Bare Wire:** Unscrew the post cap, feed the uninsulated wire through the resulting opening, and then securely tighten the post to establish the connection.
- **Clips/Leads:** Standard alligator or test clips can be attached to the posts. Use caution to prevent damage to the threads or the plastic housing of the terminal posts when using clips.

The primary resistance output is delivered between the RED and BLACK terminals. The WHITE terminal serves as a case ground and is typically not utilized for standard resistance setting.

- Connect the positive potential lead from the circuit or device being tested to the RED terminal.
- Connect the negative/return lead to the BLACK terminal.

Only use the WHITE grounding terminal if the device under test explicitly requires grounding to the chassis of the resistance box.

Resistance Value Setting (Range Selection)

The 28 selector switches on the front panel are used to configure the total resistance value presented across the RED and BLACK output terminals.

- When a selector switch is placed in the IN position, the resistance value marked directly above it is added to the total output resistance.
- When the switch is set to the OUT position, the resistance value is excluded from the total.

continued...

If all switches are set to OUT, the resulting output resistance is nominally zero (plus the maximum internal resistance of approximately 0.3 Ω).

Example: To set the output resistance to a value of 10.5 k Ω , you would move the switches corresponding to 10 k Ω , 400 Ω , and 100 Ω to the IN position.

Important Operating Limits

Warning: To prevent damage to the resistance decade box and ensure user safety, observe the following maximum voltage and power limits:

- **Resistance Terminals (RED and BLACK):** The maximum voltage that can be safely applied across the output resistance terminals is 250 V AC or 250 V DC. This voltage limit must not be exceeded, even though the internal resistor components are rated for 1 W of power dissipation.

Power Dissipation Note

Note: The internal resistor power rating is 1 W per component. When testing with an external source, the applied voltage must not cause the power dissipated in any individual resistor to exceed this limit, with the 250 V AC/DC voltage rating taking priority.

Calibration Verification (Testing)

This decade box is an effective tool for checking the accuracy and functionality of various measuring instruments such as Multimeters, LCR meters, and Calibrators.

1. Establish connections to the device under test as outlined in the Terminal Connections section above.
2. Adjust the resistance switches to provide the desired or known resistance value.

continued...

3. Ensure that the voltage or current supplied by the device under test does not overload the 1 W internal resistor power rating or the maximum 250 V AC/DC limit (as noted in Important Operating Limits).
4. The device under test should then display a reading that matches the resistance value you have selected on the decade box.

If the reading on the device under test significantly deviates from the selected resistance, it may indicate a need for the device under test to undergo recalibration, adjustment, or repair.

Product Care

To keep your instrument in good working order we recommend the following:

- Store your product in a clean, dry place.
- Change the battery as needed.
- If your instrument isn't being used for a period of one month or longer please remove the battery.
- Clean your product and accessories with biodegradable cleaner. Do not spray the cleaner directly on the instrument. Use on external parts only.

Product Warranty

REED Instruments guarantees this instrument to be free of defects in material or workmanship for a period of one (1) year from date of shipment. During the warranty period, REED Instruments will repair or replace, at no charge, products or parts of a product that proves to be defective because of improper material or workmanship, under normal use and maintenance. REED Instruments total liability is limited to repair or replacement of the product. REED Instruments shall not be liable for damages to goods, property, or persons due to improper use or through attempts to utilize the instrument under conditions which exceed the designed capabilities. In order to begin the warranty service process, please contact us by email at 1-877-849-2127 or info@reedinstruments.com to discuss the claim and determine the appropriate steps to process the warranty.

Product Disposal and Recycling



Please follow local laws and regulations when disposing or recycling your instrument. Your product contains electronic components and must be disposed of separately from standard waste products.

Product Support

If you have any questions on your product, please contact your authorized REED distributor or REED Instruments Customer Service by phone at 1-877-849-2127 or by email at info@reedinstruments.com.

Please visit www.REEDInstruments.com for the most up-to-date manuals, datasheets, product guides and software.

*Product specifications subject to change without notice.
All rights reserved. Any unauthorized copying or reproduction of this manual is strictly prohibited without prior written permission from REED Instruments.*

REED INSTRUMENTS

TEST & MEASURE WITH CONFIDENCE



Access Our
Product Guide



www.REEDInstruments.com

1.888.610.7664

 www.calcert.com

sales@calcert.com

REED INSTRUMENTS



THERMAL



LIGHT



MULTIMETERS



MOISTURE



SOUND



AIR VELOCITY



THICKNESS



CLAMP METERS

www.REEDInstruments.com

1.888.610.7664

 www.calcert.com

sales@calcert.com