

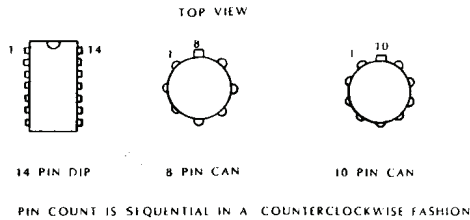

PRO-S
LAB STATION

USER MANUAL

IC IDENTIFICATION



PIN 1 LOCATION

CAN STYLE TAB IS ALWAYS PLACED ON HIGHEST PIN NUMBER WITH PIN 1 TO THE LEFT SIDE

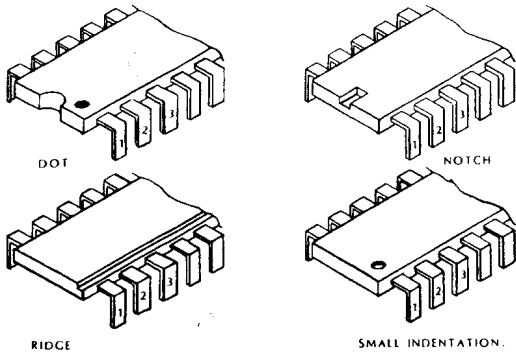

TABLE OF CONTENTS

Introduction	Page 2
Figure 1. PRO-S Assembly	Page 3
How to Work with Solderless	
Breadboards.....	Page 4
Identifying Resistor Values and Tolerances	Page 6
Identifying Capacitor Values, Tolerances and Polarity	Page 7
Identifying Diodes and LED's and their Polarity	Page 8
Identifying Transistors and their Lead Arrangement	Page 9
Identifying FETs and their Lead Arrangement	Page 11
Identifying Integrated Circuits and their Lead Arrangement	Page 12

INTRODUCTION

EXPERIMENTERS NOTES is intended to be a general guide for the experimenter who works with solderless breadboarding systems, and the discrete components that are commonly used with these systems. Although the components used are standard items, their use with solderless breadboards sometimes requires them to be modified slightly, and we will discuss how this can be done.

This guide will also show you how to determine the electrical value of various components. This value is occasionally written on the component in plain english, but is frequently shown by the use of a color code (a series of bands of color on the component), or an abbreviated series of standards, and are not difficult to understand. The same holds true for polarity indicators, which appear on all diodes as well as on some types of capacitors.

Another important concept is that of the lead arrangement of semiconductor devices, namely transistors and integrated circuits. To insure that all connections are made correctly, one must view the part from the correct position, and count the pins in the correct direction. This will be described in detail, with examples shown.

It is highly recommended that the experimenter read these NOTES completely before beginning any circuit breadboarding, and then refer to them as needed in the future. You will find that much of the information will become almost second nature, and you will eventually commit most of it to memory without even trying. Nonetheless, it is suggested that you retain these NOTES for future reference.

2

F.E.T. IDENTIFICATION

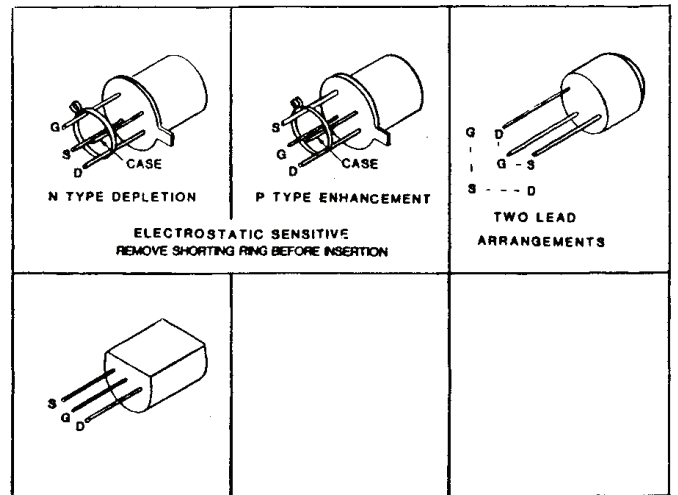

11

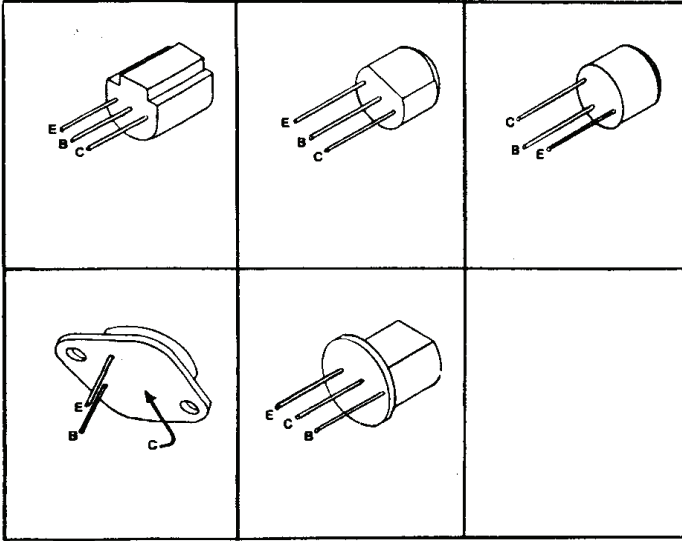

10

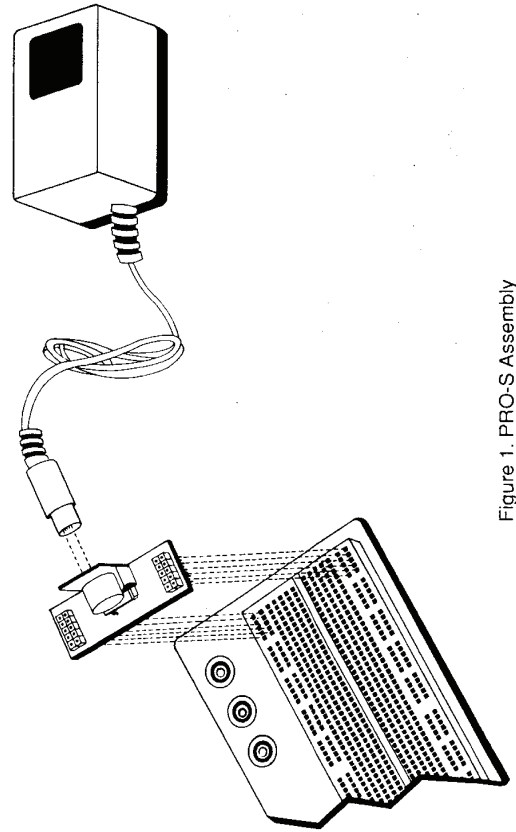

Figure 1. PRO-S Assembly

3

TRANSISTOR IDENTIFICATION

HOW TO WORK WITH SOLDERLESS BREADBOARDS

A solderless breadboard is an extremely useful device which allows you to interconnect electronic components in an almost endless variety of ways to produce working circuits. More importantly, it makes it easy to modify or completely revise these circuits quickly, and without use of any tools. And since it eliminates the possibility of overheating and damaging them, and it allows them to be used over and over.

Mechanically, the solderless breadboard is a set of formed metal sockets inserted into a plastic housing which holds them firmly in place. The pattern seen from the top is designed to provide a useful combination of isolated tie points as well as continuous bus structure. The isolated tie points serve as discrete points in the circuit you are constructing, while the busses serve, generally, to distribute power and provide common ground points.

Solderless breadboards have a very long life expectancy if treated properly. The most important thing to be aware of is the size of the wire used; we recommend using #22 AWG solid wire only. Wire which is too small may lead to poor or intermittent connections. Wire which is too large may deform the internal metal sockets to the point where they will not grip the proper wire size any more, rendering the breadboard useless. A second caution is to avoid soldering a wire which is inserted into a solderless breadboard, as it may cause the plastic surrounding the pin to melt, or may remove the temper from the metal rendering it electrically unreliable.

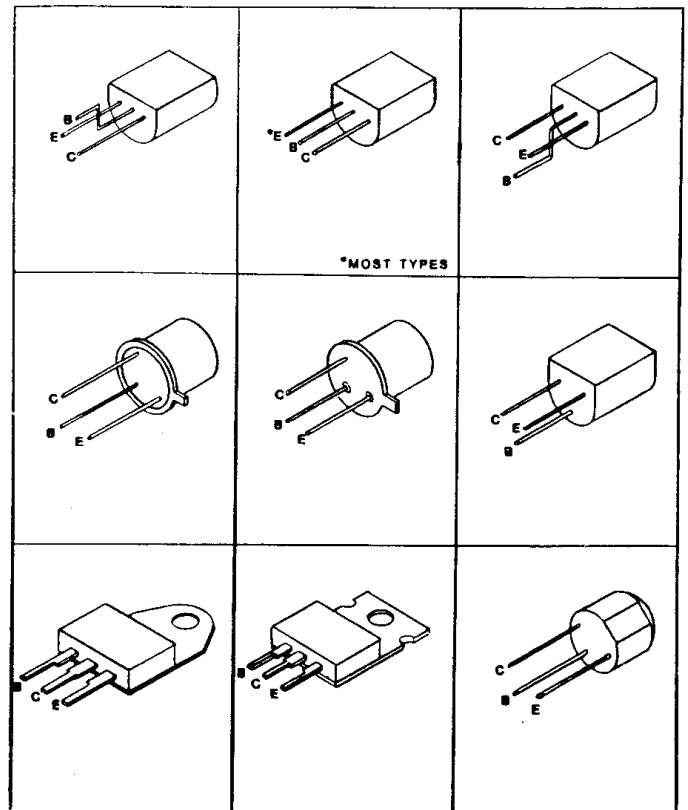

DIODE & LED IDENTIFICATION

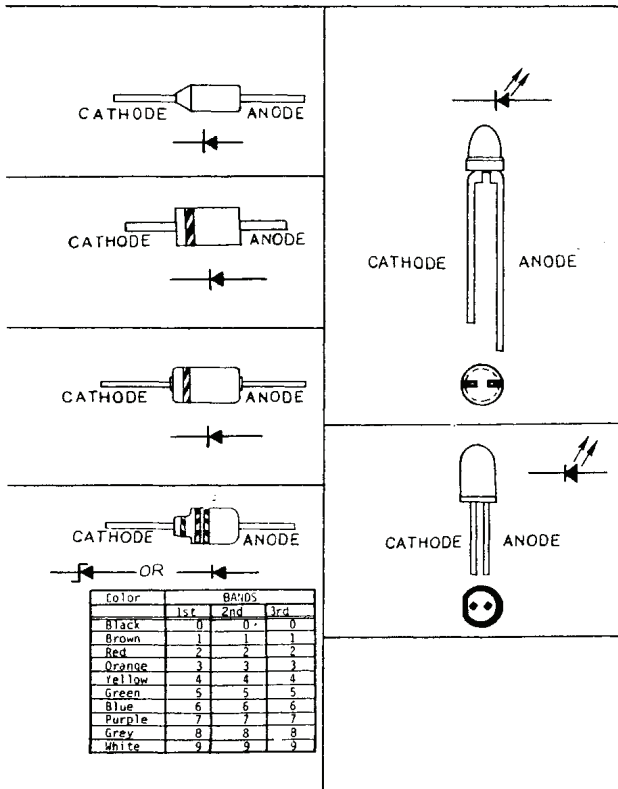

8

IC's are inserted by lining up the leads with the contact holes on each side of the center of the "socket", then pressing gently at the center of the IC until it drops into position. Withdrawing the IC can be tricky. You should use an IC removal tool if one is available to you, but a small screwdriver will also work. Slide the end of the screwdriver blade under one end of the IC and lift gently. Repeat on the other side. Continue this process until the IC is free of the socket.

IC's in TO-5 or similar cases can be accommodated by performing their leads to resemble a DIP package. This is best done with a pair of needle nose pliers. Similarly, transistors leads can be formed to fit the breadboard configuration.

Special components such as pushbuttons, switches, potentiometers, etc. can be used by soldering a short length of #22 AWG solid wire to each of their terminals and then inserting these in the breadboard. This approach is also recommended where you must connect stranded wire to a breadboard, such as when using battery clips.

If you should want to make a permanent version of a circuit you have built up on a breadboard, a printed circuit board is available which has exactly the same layout as the solderless breadboard. This enables you to easily transfer all components, in their original positions, to a permanent PC board.

5

RESISTOR IDENTIFICATION

Resistor Color Code Chart #1
3 significant figures (1%)

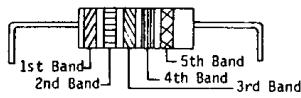

Color	BANDS				
	1st	2nd	3rd	4th	5th
Black	0	0	0	X 1.0	
Brown	1	1	1	X 10	1%
Red	2	2	2	X 100	.1%
Orange	3	3	3	X 1000	.01%
Yellow	4	4	4	X 10000	.001%
Green	5	5	5	X 100000	
Blue	6	6	6	X 1000000	
Purple	7	7	7	--	
Grey	8	8	8	--	
White	9	9	9	--	
Gold	-	-	-	+ 10	
Silver	-	-	-	+ 100	
----	-	-	-	--	

NOTE: 1,000,000 ohms = 1 MEG ohm 1,000 ohms = 1K ohms

Resistor Color Code Chart #2

Color	BANDS					RC-MIL-R-39008
	1st	2nd	3rd	4th	5th	
Black	0	0	X 1.0	-		
Brown	1	1	X 10	-		
Red	2	2	X 100	-		
Orange	3	3	X 1000	-		
Yellow	4	4	X 10000	-		
Green	5	5	X 100,000	-		
Blue	6	6	X 1,000,000	-		
Purple	7	7	--	--		
Grey	8	8	--	--		
White	9	9	--	--		
Gold	-	-	+ 10	+ 5%		
Silver	-	-	+ 100	+ 10%		
----	-	-	-	+ 20%		RC-MIL-R-11

CAPACITOR IDENTIFICATION

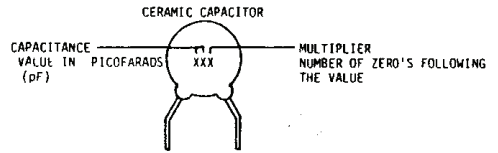

EXAMPLES: 103 = 10000 pF OR .01 μ F
302 = 3000 pF OR .003 μ F
676 = 6700000 pF OR 67 μ F

Note: To get μ F from pF, move the decimal point 6 places to the left.

ELECTROLYTIC CAPACITOR

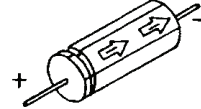

CAPACITANCE IS INDICATED ON CAPACITOR IN MICROFARADS (μ F)

TANTALUM CAPACITOR

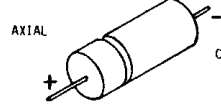

CAPACITANCE IS INDICATED ON CAPACITOR IN MICROFARADS (μ F)

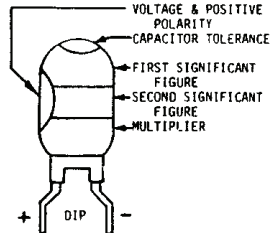

COLOR	VOLTAGE	VALUE	MULTIPLIER
BLACK	4	0	-----
BROWN	6	1	-----
RED	10	2	-----
ORANGE	15	3	-----
YELLOW	20	4	10000
GREEN	25	5	100000
BLUE	35	6	1000000
VIOLET	50	7	10000000
GRAY	-----	8	-----
WHITE	-----	9	-----

CAPACITANCE MAY BE MARKED ON CAPACITOR IN MICROFARADS (μ F) OR BY COLOR CODE IN PICOFARADS (pF)