

WATLOW® EZ-ZONE® PM Express Panel Mount Controller

Simple to Use,
Ideally Suited for
Basic Applications or
Usage Levels



The Watlow® EZ-ZONE® PM Express panel mount controller is an industry leading PID controller that allows optimal performance utilizing simple control and menu functionality without complex features. It is ideally suited for basic applications and usage levels.

The EZ-ZONE PM Express is the next generation controller to follow the legacy of Watlow's SERIES 93, SERIES 935 and SERIES SD controllers that offer easy-to-use features to perform many basic applications. The EZ-ZONE PM Express includes one universal input and an option for up to two outputs and is available in 1/32, 1/16, 1/8 and 1/4 DIN panel mount packages. It can be ordered as a PID process controller or as a dedicated over and under-temperature limit controller.

The EZ-ZONE PM Express is a valuable addition to the EZ-ZONE PM controller family which also includes the EZ-ZONE PM integrated controller and the EZ-ZONE PM standard version.

Features and Benefits

Simplified menu

- Fits basic applications with a user-friendly interface supported by two menus and a streamlined list of parameters
- Eliminates user complexity often experienced with more advanced controllers and unnecessary features
- Reduces user training costs and user programming errors

PID auto-tune

- Provides auto-tune for fast, efficient start-up

Standard bus communications

- Allows easy product configuration via PC communications protocol and free software
- Saves time, simplifies programming process and improves reliability of controller setup

Features and Benefits (con't)

EZ-LINK mobile application for iPhone® and Android™

- Expedites controller setup with intuitive navigation
- Simplifies setting parameters with plain text names and descriptions
- Connects quickly and easily via Bluetooth® wireless communications



Agency approvals: UL® listed, CSA, CE, RoHS, W.E.E.E., FM, SEMI F47-0200, Class 1, Div. 2 rating on selected models

- Assures prompt product acceptance
- Reduces end product documentation costs

Front panel removable

- Saves time and labor with replacements and troubleshooting

P3T armor sealing system

- Compiles to NEMA 4X, IP65 specifications
- Allows controller to be cleaned and washed
- Certified UL® 50 independent to NEMA 4X specification

Touch-safe package

- Increases installer and operator safety
- Complies with IP2X requirements

Three-year warranty

- Demonstrates Watlow's reliability and product support

High-ampere power control output

- Drives 15 ampere resistive loads direct
- Reduces component count
- Saves panel space and simplifies wiring
- Reduces cost of ownership



Specifications

Line Voltage/Power

- 85 to 264VAC, 47 to 63Hz
- 20 to 28VAC, +10/-15%; 50/60Hz, $\pm 5\%$
- 12 to 40VDC
- 10VA ($1/32$ and $1/16$ DIN), 14VA ($1/8$ and $1/4$ DIN) max. power consumption
- Data retention upon power failure via non-volatile memory
- Compliant with SEMI F47-0200, Figure R1-1 voltage sag requirements @ 24VAC or higher

Environment

- 0 to 149°F (-18 to 65°C) operating temperature
- -40 to 185°F (-40 to 85°C) storage temperature
- 0 to 90% RH, non-condensing

Accuracy

- Calibration accuracy and sensor conformity: $\pm 0.1\%$ of span, $\pm 1^\circ\text{C}$ @ the calibrated ambient temperature and rated line voltage
 - Type R, S, B: 0.2%
 - Type T below -50°C : 0.2%
- Calibration ambient temperature @ 77°F $\pm 5^\circ\text{F}$ ($25^\circ\text{C} \pm 3^\circ\text{C}$)
- Accuracy span: 1000°F (540°C) min.
- Temperature stability: $\pm 0.1^\circ\text{F}/^\circ\text{F}$ ($\pm 0.1^\circ\text{C}/^\circ\text{C}$) rise in ambient max.

Agency Approvals

- cULus® UL/EN/CSA C22.2 No 61010-1 Listed, File E185611
- CSA C22.2 No. 24, File 158031
- UL® 50 4X indoor locations, NEMA 4X, IP65 front seal
- cULus® ANSI/ISA 12.12.01-2007, CSA-C22.2 No. 213-1987, Class 1, Div. 2, Groups A, B, C and D, temperature code T4A, File E184390 (optional)
- CE, RoHS by design, W.E.E.E.
- FM Class 3545 (limit controls)

Controller

- User selectable heat/cool, on-off, P, PI, PD, PID or alarm action, not valid for limit controllers
- Auto-tune with control algorithm
- Control sampling rates: input = 10Hz, outputs = 10Hz
- Input and output capacity per controller type ordering information

Serial Communications

- Isolated communications
- Standard bus configuration protocol

Wiring Termination—Touch-Safe Terminals

- Input, power and controller output terminals are touch safe removable 12 to 22 AWG

Universal Input

- Thermocouple, grounded or ungrounded sensors, greater than 20M Ω input impedance, 2k Ω source resistance max.
 - Non-isolated to switched dc and process output
- RTD 2- or 3-wire, platinum, 100 Ω @ 0°C calibration to DIN curve (0.00385 $\Omega/\Omega/^\circ\text{C}$)
- Process, 4-20mA @ 100 Ω , or 0-10VDC @ 20k Ω input impedance; scalable

Functional Operating Range

- Type J: -346 to 2192°F (-210 to 1200°C)
- Type K: -454 to 2500°F (-270 to 1371°C)
- Type T: -454 to 750°F (-270 to 400°C)
- Type E: -454 to 1832°F (-270 to 1000°C)
- Type N: -454 to 2372°F (-270 to 1300°C)
- Type C: 32 to 4200°F (0 to 2315°C)
- Type D: 32 to 4200°F (0 to 2315°C)
- Type F: 32 to 2449°F (0 to 1343°C)
- Type R: -58 to 3214°F (-50 to 1767°C)
- Type S: -58 to 3214°F (-50 to 1767°C)
- Type B: 32 to 3300°F (0 to 1816°C)
- RTD (DIN): -328 to 1472°F (-200 to 800°C)
- Process: -1999 to 9999 units

Output Hardware

- Switched dc = 22 to 32VDC @ 30mA
- Open collector = 30VDC max. @ 100mA max. current sink
- Solid state relay (SSR), Form A, 0.5A @ 24VAC min., 264VAC max., opto-isolated, without contact suppression
- Electromechanical relay, Form C, 24 to 240VAC or 30VDC max., 5A resistive load, 100,000 cycles at rated load
- Electromechanical relay, Form A, 24 to 240VAC or 30VDC max., 5A resistive load, 100,000 cycles at rated load
 - Output 2 is limit for limit models
- NO-ARC relay, Form A, 24 to 240VAC, 15A @ 122°F (50°C), resistive load, no VDC, 2 million cycles at rated load
- Universal process output: range selectable; 0 to 10VDC $\pm 15\text{mV}$ into a min. 1,000 Ω load with 2.5mV nominal resolution; 4 to 20mA $\pm 30\mu\text{A}$ into max. 800 Ω load with 5 μA nominal resolution; temperature stability 100ppm/°C

Operator Interface

- Dual 4 digit, 7 segment LED displays
- Typical display update rate 1Hz
- Advance, infinity (RESET), up and down keys plus an A/M-KEY for control or EZ-KEY(S) for limit (not available in $1/32$ DIN)
- Infinity key is also labeled RESET on limit control models
- A/M-KEY on $1/16$ DIN package automatically programmed as an auto/manual transfer mode function on PID models.
- EZ1-KEY on $1/8$ and $1/4$ DIN packages automatically programmed as an auto/manual transfer mode function on PID models.

Typical Block Diagram

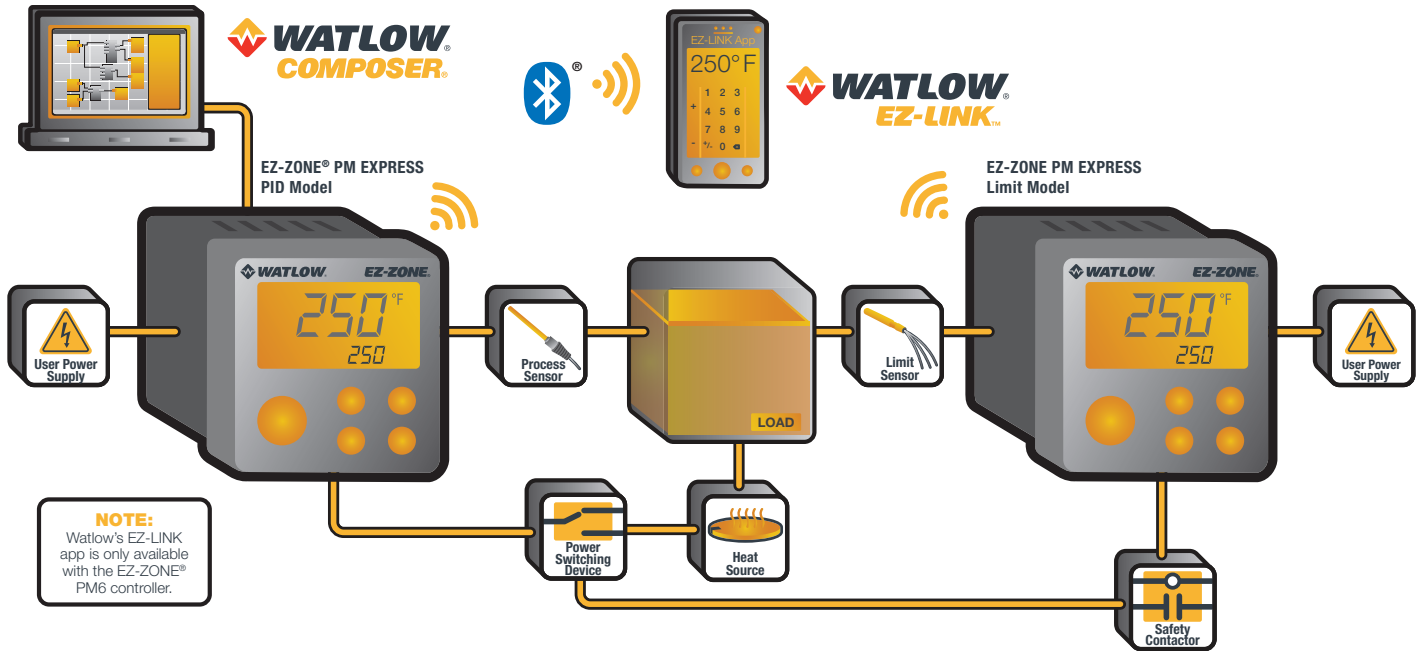

Dimensional Drawings

EZ-ZONE PM 1/32 DIN

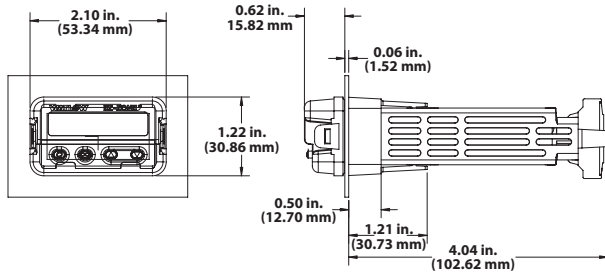

EZ-ZONE PM 1/16 DIN

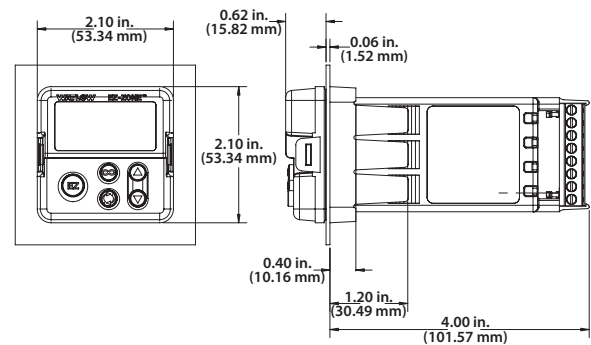

EZ-ZONE PM 1/8 DIN - HORIZONTAL

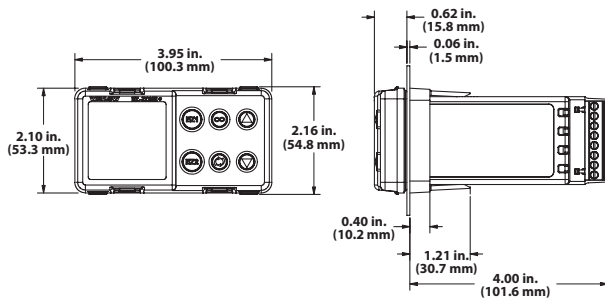

EZ-ZONE PM 1/8 DIN - VERTICAL

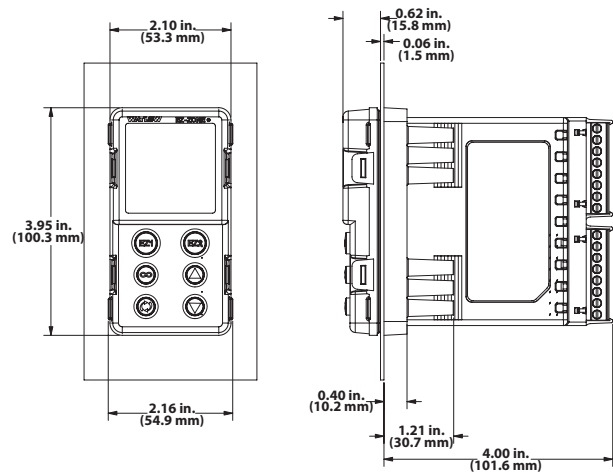

EZ-ZONE PM 1/4 DIN

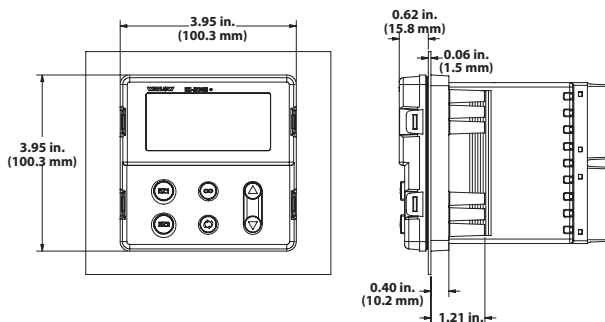

Ordering Information

Part Number

Universal Sensor Input, Standard Bus Communications, Dual Line Red over Green Seven-Segment Displays

① ②	③	④	⑤	⑥ ⑦	⑧	⑨ ⑩ ⑪	⑫	⑬ ⑭
PM	Package Size	Primary Functions	Power Supply	Output 1 and 2 Hardware Options	Comm. Options	Future Options	Menu Type	Add'l Options
					-	AAA	B	

③ Package Size	
3 =	1/32 DIN
6 =	1/16 DIN
8 =	1/8 DIN vertical
9 =	1/8 DIN horizontal
4 =	1/4 DIN

④ Primary Functions	
C =	PID controller with universal input
L =	Limit controller with universal input (only valid Output 1 and 2 selections = AJ, CJ or EJ)
S =	Custom PID firmware
D =	Custom limit firmware

⑤ Power Supply	
1 =	100 to 240VAC
3 =	20 to 28VAC or 12 to 40VDC

⑥ ⑦ Output 1 and 2 Hardware Options		
	Output 1	Output 2
AJ =	None	Mechanical relay 5A, Form A
CA =	Switched dc/open collector	None
CH* =	Switched dc/open collector	NO-ARC 15A power control
CC =	Switched dc/open collector	Switched dc
CJ =	Switched dc/open collector	Mechanical relay 5A, Form A
CK =	Switched dc/open collector	SSR Form A, 0.5A
EA =	Mechanical relay 5A, Form C	None
EH* =	Mechanical relay 5A, Form C	NO-ARC 15A power control
EC =	Mechanical relay 5A, Form C	Switched dc
EJ =	Mechanical relay 5A, Form C	Mechanical relay 5A, Form A
EK =	Mechanical relay 5A, Form C	SSR Form A, 0.5A
FA =	Universal process	None
FC =	Universal process	Switched dc
FJ =	Universal process	Mechanical relay 5A, Form A
FK =	Universal process	SSR Form A, 0.5A
AK =	None	SSR Form A, 0.5A
KH* =	SSR Form A, 0.5A	NO-ARC 15A power control
KK =	SSR Form A, 0.5A	SSR Form A, 0.5A

* Not available with the 1/32 DIN (PM3) package size.

⑧ Communications Options	
Standard bus always included	
A =	None
B =	Bluetooth® (1/16 DIN models only)*
*Note: Bluetooth® not available in all countries, consult factory.	

⑫ Menu Type	
B =	PM Express with English manual

⑬ ⑭ Additional Options	
AA =	Standard EZ-ZONE PM face plate
AB =	EZ-ZONE logo, no Watlow name
AC =	No logo, no Watlow name
AG =	Conformal coating
12 =	Class 1, Div. 2 (not available with mechanical relay output types E, H or J)

Watlow®, Watlow **SELECT**®, EZ-ZONE® and COMPOSER® are registered trademarks of Watlow Electric Manufacturing Company.
 EZ-LINK™ is a trademark of Watlow Electric Manufacturing Company.
 UL® and cUL® are registered trademarks of Underwriter's Laboratories, Inc.
 Android™ is a registered trademark of Google LLC.
 The Bluetooth™ word mark and logo are registered trademarks of Bluetooth® SIG, Inc.
 iPhone® is a registered trademark of Apple Corporation.

Powered by Possibility