



PCAL300

Loop Calibrator (Source and Measure)



1 Safety Information

Users should use the calibrator in accordance with the instructions in the Manual, or the protective measures provided by the calibrator may be damaged. The Company is not responsible for any damage caused by failure to follow the safety warning information provided.

“**⚠WARNING**” indicates a situation or action that may pose a danger to the user. “Caution” indicates a situation or action that may cause damage to the calibrator or the equipment being tested. Please refer to Table 1 for an explanation of international electrical symbols used in the calibrator and the Manual.

Table 1. International Electrical Symbols

	Earthing		Warning Message
---	----------	---	-----------------

⚠WARNING

To avoid electric shock or personal injury:

- Do not apply voltage exceeding the rated voltage indicated on the calibrator between terminals or between any terminal and ground.
- Before use, measure a known voltage to verify that the calibrator is working properly.

- Please follow all safety steps of the equipment.
- Do not use a damaged calibrator. Check the housing of the calibrator for cracks or missing plastic parts before use. Pay special attention to the insulation around the connector.
- Select the correct function and range according to the measurement requirements.
- Make sure that the battery door is securely closed before using the calibrator.
- Remove the test lead from the calibrator before opening the battery door.
- Check the test lead for damage or exposed metal. Check if the test lead is conductive. The damaged test lead should be replaced before using the instrument.
- When using the probe, keep your fingers away from its metal contact. Keep your fingers behind the finger protection device of the probe.
- When wiring, the common wire should be connected first and then the live test lead. When removing wires, remove the live test lead first.
- Do not use the instrument if it is malfunctioning. Protective measures may have been damaged. If in doubt, send the instrument for repair.
- Do not use the instrument near explosive gases, vapors, or dust.
- The Calibrator should be powered by 3 AA LR6 batteries, which should be properly installed in the instrument housing.
- Remove the test lead first before switching between different measurement or output functions.
- When repairing the calibrator, use the designated replacement parts.
- To avoid incorrect readings that could result in possible electric shock or personal injury, the battery should be replaced immediately when the symbol “” appears on the display screen indicating low battery

2 Get to Know the Calibrator

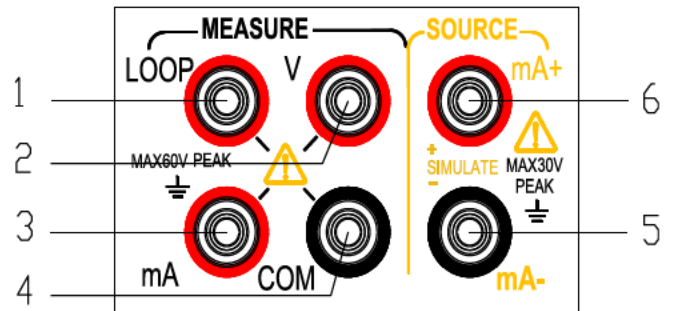
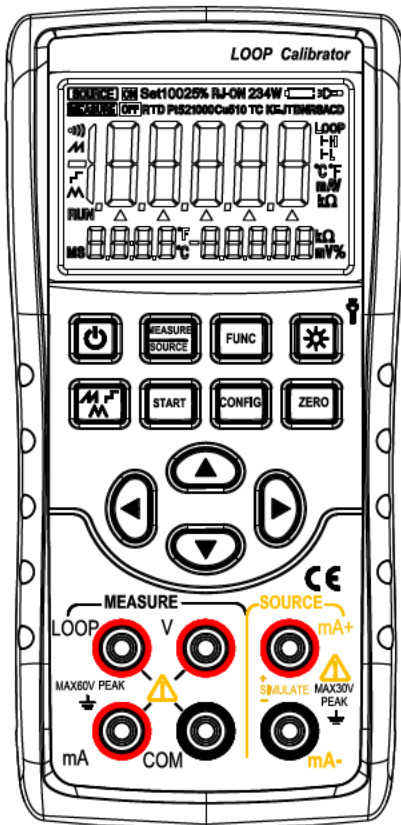

Figure 1. Overall diagram

2.1 Input and output terminals

Figure 2 shows the input and output terminals of the calibrator.

Table 2 explains their purpose.

2. Input/output terminals

Terminal	Function Description
1	LOOOP terminal: 24V loop power external terminal
2	V terminal: DCV measurement (+) input terminal
3	mA terminal: DCI measurement (+) input terminal
4	Common (-) (return) terminal for all inputs
5	mA- terminal: DCI output (-) terminal
6	mA+ terminal: DCI output (+) terminal

Figure 2. Input/output terminals

5.2 Buttons

Figure 3 shows the calibrator buttons. Table 3 explains their functions.

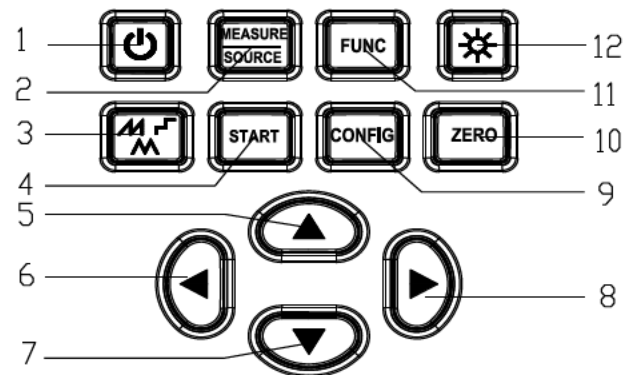

Figure 3. Button Functions

Table 3. Button Functions

SN	Button name	Description
1	Power button	Power on/off
2	MEASURE/SOURCE	Input/output state switching
3	Output waveform switch button	Output waveform selection of current output automatic waveform
4	Output START button	Start/stop button for automatic waveform output in the output current function
5, 7	Output setting button	Output setting position increase/decrease
6, 8	Output setting button	Output setting position left/right shift
9	CONFIG button	In the output current function, press this button to enter current-related parameter settings
10	ZERO button	In the output state, press this button to restore the output value to the default value. Press this button to save the settings in states of factory maintenance setting and parameter setting.
11	FUNC button	Press this button to switch functions
12	Backlight/flashlight button	Short press to turn on/off the backlight; long press to turn on/off the flashlight

6 Preparations

■ Operating precautions

Safe use of the calibrator

- When using the calibrator for the first time, be sure to read the safety information listed in Section IV.

- Do not open the instrument housing.

To inspect or repair the instrument's internal components, please contact the seller from whom you purchased the product.

- Malfunctioning Conditions

If the instrument starts to release smoke, emits a strange smell, or shows other abnormal phenomena, immediately turn off the instrument and remove the batteries. Then contact the seller from whom you purchased the instrument.

■ General operations

- Before moving the calibrator, turn off the power of the tested instrument, and then turn off the power of the calibrator. Finally, unplug all test leads from the calibrator. When transporting the calibrator, use a professional transport packaging box.

- Do not allow any live objects to approach the calibrator in case its internal circuit gets damaged.

- Do not use any volatile chemicals on the calibrator housing and operator panel, and do not leave the calibrator attached to any object made of rubber or vinyl for too long. Take care to prevent the operating panel, which is made of thermoplastic resin, from contacting the soldering iron, soldering tin or heating objects.

- For safe operations of the battery, please refer to the "Install or replace batteries" section.

- Do not use the calibrator without the battery cover installed.

■ Environmental requirements

Use the instrument under the environmental requirements listed below:

- Ambient Temperature and Humidity

Ambient temperature: 0-50°C

Ambient humidity: 20%-80%; use the instrument under non-condensing conditions

- Use it in a flat and horizontal area
- Do not use the instrument in the following environment
- Places directly exposed to sunlight or close to heat sources
- Places close to mechanical vibrations
- Approaching any interference source, such as high-voltage equipment or engine power
- Approaching any electromagnetic field or high-density electric power area
- Places filled with large amounts of oil fumes, heat flow, dust or corrosive gases
- Unstable places or places with flammable gases that can cause an explosion

Note:

- If precise measurements or output results are required, use the calibrator under the following environmental requirements:
Ambient temperature range: $23\pm 5^{\circ}\text{C}$; ambient humidity range: 20-80% (without condensation)
When using the calibrator in an environment of $0-18^{\circ}\text{C}$ or $28-50^{\circ}\text{C}$, to achieve the given accuracy, refer to the Index section and add an additional error value at this temperature coefficient.
- When the humidity of the surrounding environment where the instrument is located is less than 30%, use an anti-static pad or take other effective measures in order to prevent the generation of static electricity.
- If the instrument needs to be moved from a place with lower ambient temperature or humidity to a place with higher ambient temperature, or if the instrument is to undergo a sudden temperature change. In this case, warm up the instrument for at least one hour at the ambient temperature before using the instrument to ensure proper operation.

- Install or replace batteries



WARNING

- To avoid electric shock, the test lead must be removed from the calibrator before opening the battery door. The battery door must be

closed tightly before using the calibrator.

Caution

- To prevent the risk of liquid leakage or battery explosion, install the positive and negative poles of the battery correctly.
- Do not short-circuit the battery.
- Do not disassemble or heat the battery, or throw the battery into a fire.
- When replacing batteries, use 3 identical batteries to replace them simultaneously.
- If the calibrator will not be used for an extended period of time, remove the batteries from the calibrator.

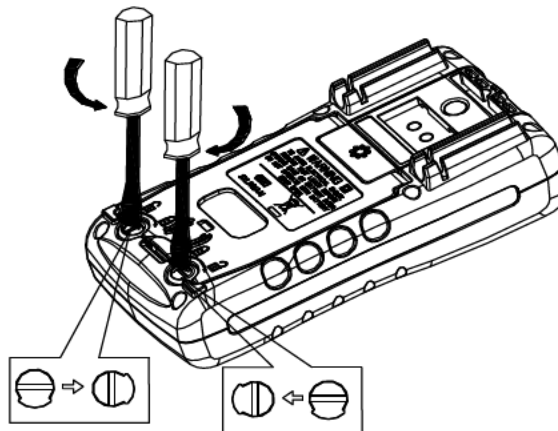

Figure 5

Step 1: Before replacing the battery, remove the test lead and turn off the calibrator.

Step 2: Use a slotted screwdriver to rotate the battery door screw by a quarter turn counterclockwise and remove the battery door.

Step 3: Correctly install 3 AA LR6 alkaline batteries into the battery compartment in the direction as it indicates.

Step 4: After replacing the batteries, close the battery door tightly again.

■ Power on/off

Press the Power button to turn on the calibrator when the power is off; press the Power button for 2 seconds to turn off the calibrator when it is on.

■ Automatic shutdown

The calibrator automatically shuts down when there is no button operation within the factory default of 5 minutes. The automatic shutdown time can be set in the factory settings. Please refer to Chapter 9 “Factory Settings”.

■ Turn the backlight on/off

Press the Backlight button to turn the backlight on, and press it again to turn the backlight off. This makes it easier to see the content on the display screen in dark places or when performing outputs or measurements. Turning on the backlight will reduce the battery life when the calibrator is operating on batteries.

Note

The backlight automatically turns off after a default of approximately 60 seconds. Press the Backlight button to re-illuminate backlight. The backlight illumination time can be set in the factory settings. Please refer to Chapter 9 “Factory Settings”.

7 Use the Output Mode

DC signal can be outputted by using the calibrator.

⚠Warning

To avoid the electric shock, the nominal voltage that exceeds the value marked on the calibrator should not be exerted between the terminals of the calibrator or between any terminal and ground. The calibrator shall be used in the occasion that the voltage of any terminal over the ground does not exceed 30V peak.

7.1 Output DC current (active)

Step 1: connect leads to the target equipment

- Connect the black lead to the output mA-end and connect the red lead to the output 'mA+' end.
- Connect the other end of the two leads to the signal end of controlled equipment and meanwhile ensure the correct polarity of the terminal.

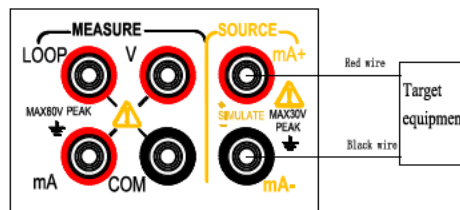

Figure 6. Output DC current (Active)

Step 2: Press (MEASURE/SOURCE) key and switch the state into the output state. The characters of 'SOURCE', 'LOOP', 'mA' on display screen will be lighted. By this time, it is the active DC current output function.

Step 3: Setting of manual stepping span and current output range:

- Press the [CONFIG] key to enter the DC current parameter setting interface. At this time, the character 'MAP.ER' is displayed in the lower right corner of the screen, indicating manual step span setting; the main display area of the screen shows the parameters to be set;
- Set the required span by pressing the (▲) / (▼) key
Parameter '0' means: When pressing the (▲) / (▼) key, the corresponding value of the setting bit increases/decreases by 1;
Parameter '25' means: When pressing the (▲) / (▼) key, the output value increases/decreases by 25% of the

measuring range;

Parameter '100' means: When pressing the (▲) / (▼) key, the output value increases/decreases by 100% of the measuring range;

Note: When the measuring range is 0-20mA, 25% span means 5mA; when the measuring range is 4-20mA, 25% span means 4mA.

When the measuring range is 0-20mA, 100% span means 20mA; when the measuring range is 4-20mA, 100% span means 16mA.



- Press the [ZERO] key to save the settings and automatically switch to the current output range setting interface. At this time, the character 'SCALE' is displayed in the lower right corner of the screen, indicating the current output range setting; the main display area of the screen shows the parameters to be set;
- Set the required range by pressing the (▲) / (▼) key: 0-20mA/4-20mA;
- Press the [ZERO] key to save the settings and automatically switch back to span setting.
- Press the [CONFIG] key to exit the setting interface.

Note: After setting the current output range, the set range applies to all current output functions.

Step 4: Set the output value by pressing the output setting key.

- Change the set output value: (▲) / (▼) ;
- Change the set output bit: (◀) / (▶) , this step is only valid when the span is '0'

7.1.1 Output current auto-stepping output mode

Step 1:  symbol of the display screen will be lighted at this time by pressing () key in the state of output current function and switching the function to DC step mode.

Step 2: The character 'STEP' at the lower right corner of the display screen indicates the step setting and the main display area in the display screen displays the parameters to be set in the entry of the DC step mode parameter setting interface by pressing

{**CONFIG**} key;

Use the {**▲**} / {**▼**} / {**◀**} / {**▶**} key to set step length required(1-200S); press {**ZERO**} key to keep and set. Then press {**CONFIG**} key to exit the setting interface.

Step 3: Press {**START**} key to start the automatic step output current, and by this time {**RUN**} signal on the display screen is lighted.

Step 4: Press {**START**} key to stop the automatic step output current when the user is going to end the automatic step output current.
By this time, {**RUN**} sign on the display screen disappears.

7.1.2 Output current automatic sawtooth wave output mode



Step 1: Press {} key and switch the function to DC automatic sawtooth wave mode in the state of output current function. By this time, \mathcal{M} symbol on display screen is lighted.













Step 2: Press {**CONFIG**} key to enter DC sawtooth wave mode parameter setting interface. By this time, the character 'START' at the lower right corner of the display screen indicates the origin current value setting and the parameters to be set in main display area on display screen; The user should utilize {**▲**} / {**▼**} / {**◀**} / {**▶**} key to set the origin current that is required; The user should press {**ZERO**} key to keep and set and switch to the next setting item. By this time, the character 'STOP' at the lower right corner of display screen indicates the terminal current value setting and the parameters to be set in the main display area on the display screen; The user should utilize {**▲**} / {**▼**} / {**◀**} / {**▶**} key to set the terminal current required; the user should press {**ZERO**}key to keep and set and switch to the next setting item and by this time, the character 'CYC' at the lower right corner of display screen indicates the period setting and the parameters to be set in the main display area on display screen; the user should utilize {**▲**} / {**▼**} / {**◀**} / {**▶**} key to set the period needed (5-200S) and press {**ZERO**} key to keep and set. And then, the user should press {**CONFIG**} key to exit the setting interface.

Step 3: Press {**START**}key again to start the automatic step output current. By this time, {**RUN**}sign on the display screen is lighted.

Step 4: Press {**START**} key to stop the automatic step output current when the user is going to end the automatic step output current.
By this time, {**RUN**} sign on the display screen disappears.

7.1.3 Output current automatic triangular wave output mode

Step 1: Press () key and switch the function to DC automatic sawtooth wave mode in the state of output current function. By this time,  symbol on display screen is lighted.

Step 2: Press (**CONFIG**) key to enter DC sawtooth wave mode parameter setting interface. By this time, the character 'START' at the lower right corner of display screen indicates origin current value setting and the parameters to be set in main display area on display screen; The user should utilize () / () / () / () key to set the origin current that is required; The user should press (**ZERO**) key to keep and set and switch to the next setting item. By this time, the character 'STOP' at the lower right corner of display screen indicates the terminal current value setting and the parameters to be set in main display area on display screen; The user should utilize () / () / () / () key to set the terminal current required; The user should press (**ZERO**) key to keep and set and switch to the next setting item and by this time, the character 'CYC' at the lower right corner of display screen indicates the period setting and the parameters to be set in main display area on display screen; The user should utilize () / () / () / () key to set the period needed (5-200S) and press (**ZERO**) key to keep and set. And then, the user should press (**CONFIG**) key to exit setting interface.

Step 3: Press (**START**) key to start the automatic step output current. By this time, (**RUN**) sign on display screen is lighted.

Step 4: Press (**START**) key to stop automatic step output current when the user is going to end the automatic step output current. By this time, (**RUN**) sign on display screen disappears.

7.2 Output DC current (passive)

Step 1: Connect the lead to the target equipment

- Connect the black lead to output mA-end and connect the red lead to output 'mA+' end.
- Connect the other end of the two leads to the input end of controlled equipment and meanwhile ensure the correct polarity of the terminal.

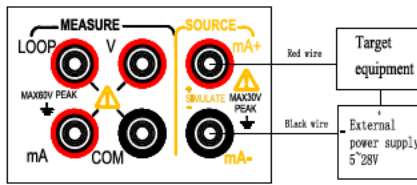

Figure 7. Output DC current (passive)

Step 2: Press (MEASURE/SOURCE) key and switch the state into the output state, and the 'SOURCE', 'LOOP', 'mA' characters on display screen will be lighted. By this time, it is the APC DC output function.

Step 3: Press (FUNC) key and switch the function to passive DC current output. The character 'SOURCE', 'mA' on display screen are lighted.

Other operations should be found in the part of active DC function.

Tips: Passive DC current needs an external 5-28V DC power supply

8 Use Measurement Mode

DC and voltage and DC current can be measured by utilizing the calibrator

⚠ Warning

- The measuring function of the calibrator is used where a lead connection is required to conduct measurement. The maximum voltage of any permissible input terminal to the ground is 60V peak. To avoid electric shock, it is inadvisable to apply any voltage above the maximum voltage to the terminal over the ground.
- The power supply of the equipment should be disconnected before connecting calibrator to the equipment under test.

- The instrument might be damaged or staff might be injured if the line is wrongly operated or wrong operation is conducted during the process of measurement. Therefore, you should pay as much attention as possible when you are performing measurement operation.

Prompt

- The “OL” symbol is displayed in the main display area of the display screen when the measured value exceeds the measuring range of this range.

8.1 Measure DC voltage

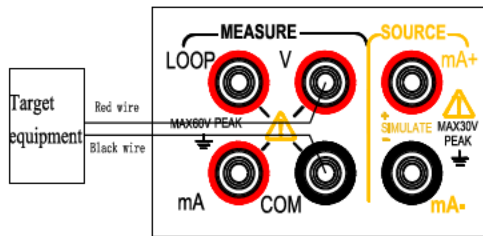

Step 1: Ensure that the measurement lead is disconnected from the equipment under test.

Step 2: Press the (MENSURE/SOURCE) button to switch the state to measurement, and the display screen (MEASURE) will light up at this moment.

Step 3: Press the (FUNC) button to switch to the DC voltage function (the default function of the measurement state is DCV), and the V character of the display screen is lighted at this moment.

Step 4: Connect the measurement lead to the signal end of the equipment under test, and the real-time measurement value is displayed in the main display area of the display screen at this moment.

Step 1: Ensure that the measurement lead is disconnected from the equipment under test.

Step 2: Press the (MEASURE/SOURCE) button to switch the state to measurement, and the display screen (MEASURE) will light up at this moment.

Step 3: Press the (FUNC) button to switch to the DC current function, and the mA and the mA and LOOP characters of the display screen are lighted at the same time.

Step 4: Connect the measurement lead to the measurement end of the equipment under test, and the real-time measurement value is displayed in the main display area of display screen at this moment.

Prompt: This function provides 24V power for the external equipment loop and measures the current value in the loop.

9 Factory Settings

The default factory settings can be changed by the calibrator.

Method of entering: Hold the backlight button, and then press the power button to start, and release the backlight button after the instrument enters the setting interface.

9.1 Automatic shutdown time setting

Step 1: "APOF" is displayed in the display screen, which indicates the automatic shutdown setting after entering the setting interface.

Step 2: Use the setting buttons such as (▲) / (▼) / (◀) / (▶) to set necessary parameters. The displayed value unit of the automatic shutdown time is minute.

Setting range: 0-60 minutes; 0 indicates canceling the automatic shutdown, and other values indicate shutting down the instrument after the corresponding time.

Step 3: Press (ZERO) button and save the setting when there is the sign of "SAVE" in the display screen.

9.2 Backlight time setting

Step 1: Press the (MEASURE/SOURCE) and the "BLOF" is displayed, indicating the backlight time setting.

Step 2: Use (▲) / (▼) / (◀) / (▶) to set necessary parameters. The displayed value unit of the backlight time is second.

Setting range: 0-3600 seconds; 0 indicates that the automatic backlight turning off is cancelled. Other values indicate that the instrument backlight is turned off after the corresponding time.

Step 3: Press the **(ZERO)** button and save the setting when there is the sign of “SAVE” in the display screen.

9.3 Flashlight time setting

Step 1: Press the **(MEASURE/SOURCE)** and the “LTOF” is displayed, indicating the flashlight time setting.

Step 2: Use **(▲)** / **(▼)** / **(◀)** / **(▶)** to set necessary parameters. The displayed value unit of the flashlight time is minute.

Setting range: 0-30 minutes; 0 indicates that the automatic backlight turning off is cancelled. Other values indicate that the instrument backlight is turned off after the corresponding time.

Step 3: Press the **(ZERO)** button and save the setting when there is the sign of “SAVE” in the display screen.

9.4 Default factory settings

Step 1: Press the **(MEASURE/SOURCE)** and the “FACT” is displayed indicating the factory default setting.

Step 2: Use **(▲)** / **(▼)** to set necessary parameters;

NO indicates that all settings are not restored to factory defaults. YES indicates that all settings are restored to factory defaults.

Step 3: Press the **(ZERO)** button and save the setting when there is the sign of “SAVE” in the display screen.

All setting factory parameters are as follows:

APOF: 5 minutes.

BLOF: 60 seconds.

LTOF: 5 minutes.

Prompt: **(ZERO)** button needs to be pressed to save the setting as long as the setting of any item is changed. Only the latest setting value is saved when **(ZERO)** button is pressed randomly.

10 Replace Battery or Fuse

⚠ Warning

The test lead wire must be removed from the calibrator before opening the battery door in order to avoid electric shock. The battery door must be closed tightly before the calibrator is utilized.

Be cautious

- Positive and negative poles of battery should be installed correctly for the purpose of preventing the danger of liquid leakage or battery explosion.
- Battery cannot be short-circuited.
- Do not remove, heat, or throw the battery into fire.
- Replace batteries with three identical batteries at the same time when they need to be replaced.
- Remove batteries from the calibrator if the calibrator will not be used for a long period of time.

Step 1: Remove the test wire and charger and turn off the calibrator, before batteries or fuses are to be replaced.

Step 2: As shown in Figure 16, use a flat-head screwdriver to turn the battery door screw one quarter of a circle counterclockwise and remove the battery door.

Step 3: Install 3 identical AA LR6 batteries correctly into the battery compartment in line with the directions indicated by the battery compartment. Or replace the same type of fuse (100mA/250V).

Step 4: Close the battery door again and lock the screw latch after batteries are replaced.

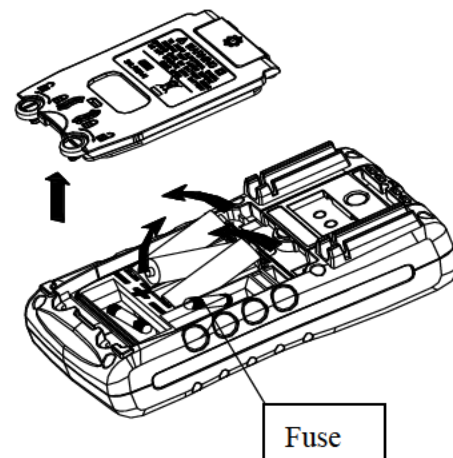

Figure 12. Replacement of batteries and fuses

11 Maintenance

11.1 Cleaning the calibrator

Warning

The specified replacement parts should be used and water is not allowed to enter the shell for the purpose of avoiding personal injury or damage to calibrator.

Be cautious

Solvents or abrasive cleaners are not allowed in order to avoid damaging plastic lenses and shells. Clean the calibrator with a soft cloth dipped in water or mild soapy water.

11.2 Calibration or reparation service center

Calibration, reparation or maintenance of the instrument should only be carried out by experienced service staff. If the calibrator is not functioning properly, batteries should be checked first and they should be replaced if necessary. It should be guaranteed that the calibrator is operated in line with the instructions in this manual. Please return the calibrator back with a fault description if the calibrator does not work properly. Please securely package the calibrator and send it to your nearest service center (please pay postage and insurance) if the original packing box is still kept. Our company is not liable for damage in transit. Calibrators covered by our warranty can be repaired or replaced quickly (at our discretion) and returned free of charge. Please refer to the warranty terms of this manual. There is certain charge for the repair of the calibrator if the warranty period has expired. Please contact our authorized service center to inquire about reparation and fees if the calibrator is not covered by the warranty. Please refer to the "Contact Us" section in the previous section of the Manual if you want to find an authorized service center.

12 Index

Input measurement function [Used within one year after calibration, 23 °C± 5 °C, 20-70% RH, accuracy within the range of ± (%setting value + character)]

Measurement function	Measurement range	Measurement scope	Resolution	Accuracy	Remarks
DCV	30V	-30.000V~30.000V	0.001V	0.02%+2mV	Input resistance: about 1MΩ
DCI	30mA	-30.000mA~30.000mA	0.001mA	0.02%+4uA	Shunt resistance: about 10Ω Input resistance: about 20Ω
LOOP	24 V			10%	

Other characteristics:

- Uncertainty includes standard uncertainty, hysteresis, nonlinearity, repeatability, and typical long-term stability over the period mentioned (K = 2).
- Display refresh rate: 2 to 3 times/second.
- Maximum voltage for the input end: 60 Vpk.
 - Input end protection: 100mA fuse.
 - Input common mode rejection: 50Hz /60 Hz >80 db; Input series mode rejection 50Hz /60 Hz > 40 db
 - Temperature factor: 0.1 × basic accuracy / °C (temperature range <18°C or >28°C)

Analog output function [Used within one year after calibration, 23 °C± 5 °C, 20-70% RH, accuracy within the range of ± (%setting value + character)]

Output function	Measurement range	Output scope	Resolution	Accuracy	Remarks
DCI	30mA	0.000mA~30.000mA	0.001mA	0.05%+4uA	In the case of 20 mA, maximum load is 1000Ωresistance, When the transmitter is simulated, the external loop provides electricity within the range of 5~28V

Other characteristics:

- Uncertainty includes standard uncertainty, hysteresis, nonlinearity, repeatability, and typical long-term stability over the period mentioned (K = 2).
- Maximum voltage for the output end: about 30 Vpk; Maximum current for the output end: about 25mA.
- Output end protection: 100mA fuse.
- Temperature factor: 0.1 × basic accuracy / °C (temperature range <18°C or >28°C)

Warranty

Triplett Test Equipment and Tools extends the following warranty to the original purchaser of these goods for use. Triplett warrants to the original purchaser for use that the products sold by it will be free from defects in workmanship and material for a period of (1) one year from the date of purchase. This warranty does not apply to any of our products which have been repaired or altered by unauthorized persons in any way or purchased from unauthorized distributors so as, in our sole judgment, to injure their stability or reliability, or which have been subject to misuse, abuse, misapplication, negligence, accident or which have had the serial numbers altered, defaced, or removed. Accessories, including batteries are not covered by this warranty

Copyright © 2024 Triplett