

# Partlow 1161+, 1801+ & 1401 Limit control



- High or Low Trip Points
- 5 Amp Latching Limit Relay
- Remote Reset Option
- Exceed & Relay Indicators
- Jumperless Configuration
- Auto Detected Hardware
- Modbus & ASCII Comms
- Two Annunciators or Alarms
- Available in 1/16, 1/8 & 1/4 DIN Formats



The Partlow range of 1161+, 1801+ and 1401+ have a programmable safety cut out with optional outputs for annunciators and alarms. A latched relay cuts power to your process if safe values are exceeded. These units must be reset before the process can continue. They have the improved Plus Series hardware and user interface for optimal ease of use.

## Specification

### Features

Output Configuration	Up to 3 possible, for latching trip relays, alarm/annunciator relays, 24VDC transmitter power supply or retransmit of process value or limit trip setpoint
Alarm 1 & 2 Types	Process high, process low, Limit SP deviation, band, logical OR alarms or trip annunciator. Alarms have fully adjustable hysteresis.
Output Reset Action	Limit output can be reset only when exceed condition is absent. Local or remote reset options.
Annunciator Reset Action	Annunciator output can be reset at any time. Local or remote reset options.
Human Interface	4 button operation, dual 4 digit 10mm & 8mm (6700+ & 8700+), 13mm & 10mm (4700+) high LED displays, optional choice of colours (Red/Red, Red/Green, Green/Red or Green/Green), plus 4 LED indicators
PC Configuration	Off-line configuration from PC serial port to dedicated config socket (comms option not required). Configuration Software for Windows 98 or higher. West Part Number: PS1-CON

### Input

Thermocouple	J, K, C, R, S, T, B, L, N & PtRh20%vsPtRh40%.
RTD	3 Wire PT100, 50Ω per lead maximum (balanced)
DC Linear	0 to 20mA, 4 to 20mA, 0 to 50mV, 10 to 50mV, 0 to 5V, 1 to 5V, 0 to 10V, 2 to 10V. Scaleable -1999 to 9999, with adjustable decimal point
Impedance	>10MΩ for Thermocouple and mV ranges, 47KΩ for V ranges and 5Ω for mA ranges
Accuracy	±0.1% of input range ±1 LSD (T/C CJC better than 1°C)
Sampling	4 per second, 14 bit resolution approximately
Sensor Break Detection	<2 secs (except zero based DC ranges), Limit trip and annunciators activate. High alarms activate for Temperature and mV ranges, low alarms activate for, mA or V ranges

### Output & Options

Limit Trip Relay Outputs	Latching SPDT, contacts 5Amp resistive at 240V AC, >100,000 operations
Alarm Relay Outputs	Non-latching SPDT, contacts 2Amp resistive at 240V AC, >500,000 operations
SSR Driver Alarm Outputs	Drive capability >10V DC in 500Ω minimum
Triac Alarm Outputs	0.01 to 1 Amp AC, 20 to 280Vrms, 47 to 63Hz
DC Linear Retransmit Outputs	0 to 20mA, 4 to 20mA into 500Ω max, 0 to 10V, 2 to 10V, 0 to 5V into 500Ω min. Accuracy ±0.25% at 250Ω (degrades linearly to 0.5% for increasing burden to specified limits)
Transmitter Power Supply	Output 24VDC (nominal) into 910Ω minimum to power external devices
Communications	2 Wire RS485, 1200 to 19200 Baud, Modbus and ASCII protocol (selectable)
Digital Input	Volt free or TTL input. -0.6 to 0.8V or contact closure resets latched relays and annunciators

## Operating & Environment

Temperature & RH  
 Power Supply  
 Front Panel Protection  
 Standards

0 to 55°C (-20 to 80°C storage), 20% to 95% RH non-condensing  
 100 to 240V ±10% at 50/60Hz 7.5VA, (optional 20 to 48V AC 7.5VA/22 to 65V DC 5 watts)  
 IEC IP66 (Behind panel protection is IP20)  
 FM, CE, UL & ULC recognised

## Dimensions

### 1161+

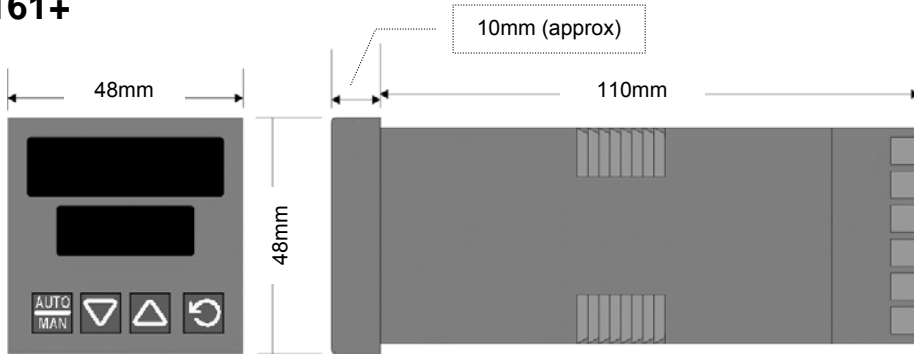

Cut-out

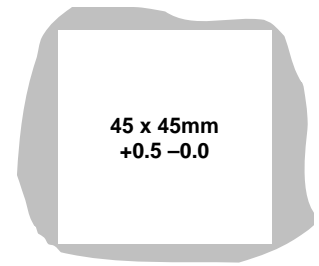

### 1801+

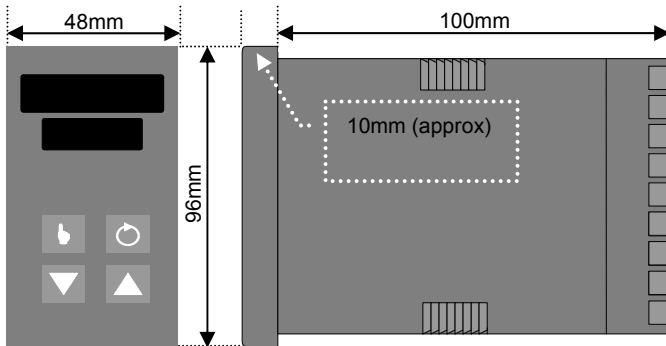

Cut-out

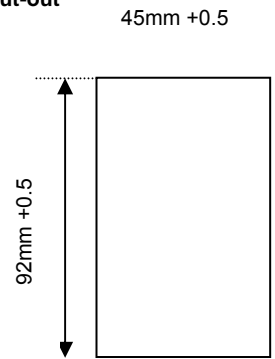

### 1401+

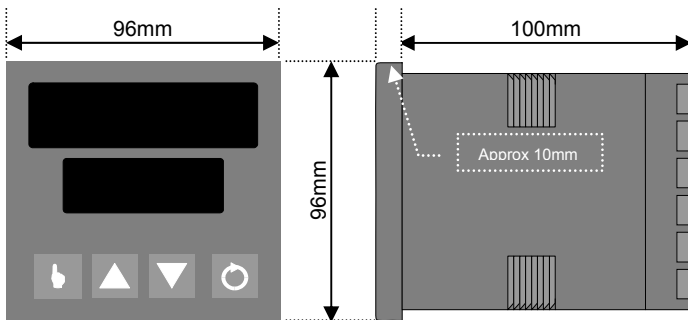

Cut-out

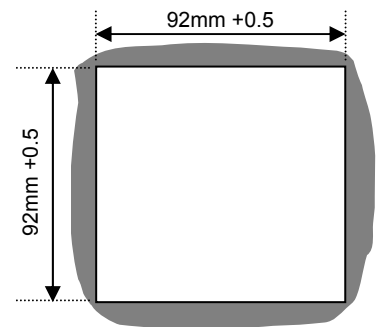

# Wiring Connections

## 1161+

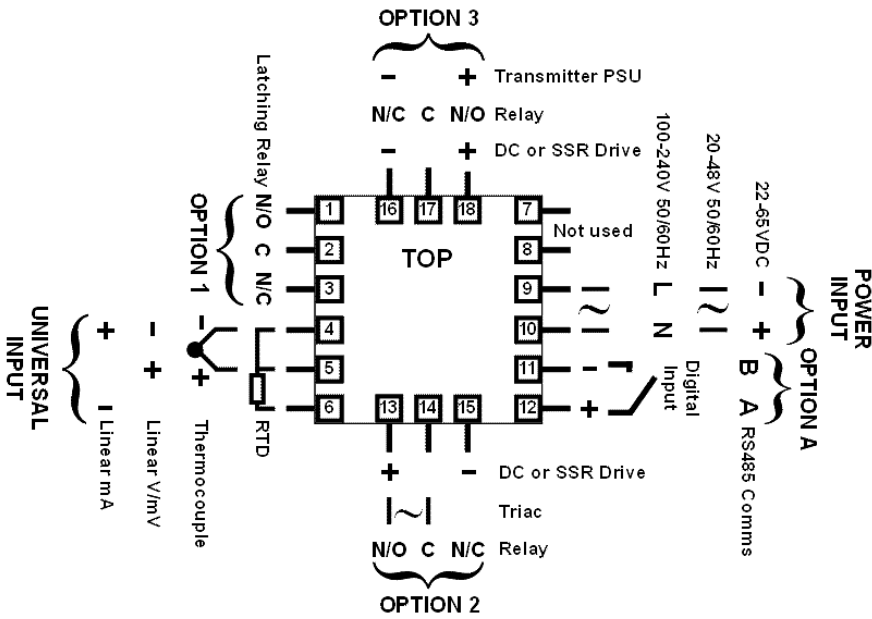

### Field Reconfiguration

#### Input

Jumper-free configuration for any type  
(no extra parts required)

#### Option Slot 1

Latching Limit Relay ..... **Fixed**

#### Option Slot 2

Relay Output ..... **Part Number**

Linear mA/V DC Output ..... **PO2-C10**

SSR Driver Output ..... **PO2-C50**

Triac Output ..... **PO2-C80**

#### Option Slot 3

Relay Output ..... **Part Number**

Linear mA/V DC Output ..... **PO2-C10**

SSR Driver Output ..... **PO2-C50**

24VDC Transmitter PSU ..... **PO2-W08**

#### Option Slot A

Digital Input ..... **Part Number**

RS485 Comms ..... **PA1-W06**

## 1801+ & 1401+

