

miniZ Intelligent Daylight Management System

Description

miniZ™ combines occupancy sensing, daylight harvesting and flexible lighting control functions into a single, easily installed package. miniZ™ features several methods of ladderless commissioning, one of which is the AutoCal feature, the world's first ever 100% self-configuring daylight harvesting system. Installation requires little more than any other power-pack type product. The performance, features, and capabilities of the miniZ™ product provide a package that surpasses all others in the industry – at a price anyone can afford.

Features

- Automatic Correction for Light Loss Factor (LLF)
- Recognizes and corrects for Lumen Maintenance Issues
- Cost effective energy code compliance
- Ladderless Commissioning™ provides install-and-forget convenience
- Automatic closed loop multi-zone daylight control
- Convenient occupancy sensor and photocell integration
- Simplified daylight harvesting with full range dimming
- Autocal™ automatic photocell calibration
- Accepts external time clock inputs
- Simplified integration with emergency systems
- Controls maximum lighting output for additional energy savings potential
- Daylight switching, full range 0-10V dimming and network models available

Simplest Install Steps

1. Physically install unit and any peripherals
2. Terminate power & control wiring
3. Enable AutoCal & Auto-Burn-In
4. Power up system
5. Installation & configuration complete!



Dimensions

- 6.65”L x 6.65”H x 2.1”D
- Shipping Weight: 4lbs.
- Unit Weight: 3.3lbs.
- 1/2” & 3/4” conduit knockouts
- 1/2” nipple with pigtails for easy line voltage connections

miniZ Intelligent Daylight Management System

Leviton Manufacturing Co., Inc. Lighting & Energy Solutions

©2013 Leviton Manufacturing Co., Inc. All rights reserved. Subject to change without notice.

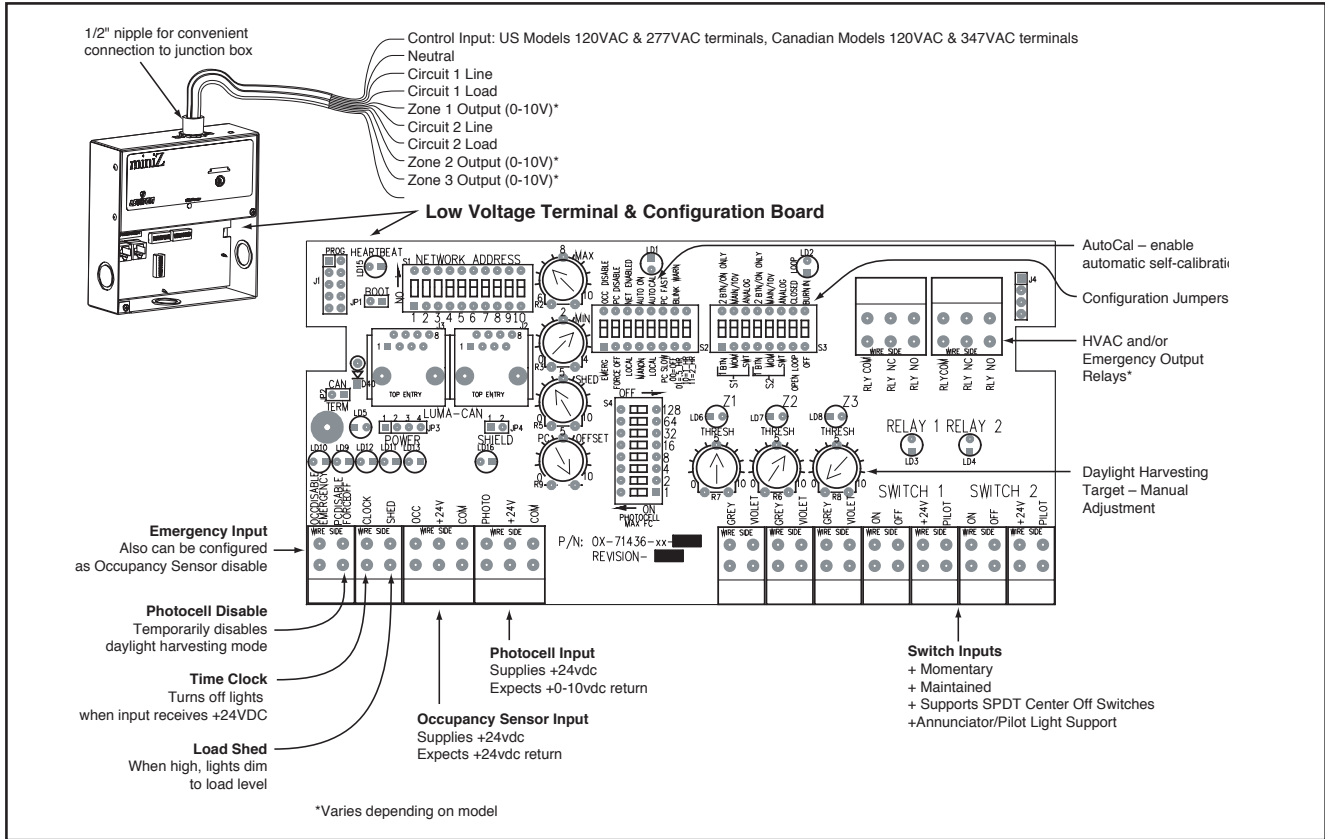

Load Ratings

- 20A per relay, 120/277V
- 15A per relay, 347V
- Fluorescent, non-dimmed and 0-10V dimmed
- 120mA power output for operation of occupancy sensors, etc.

Power

- Input Power: 120, 277, or 347V*; 10W Max, 50/60Hz
- Output Power: 1 or 2* circuits, up to 277V, 20A, or, 1 or 2* circuits, up to 347V, 15A
- Output 0-10V Control: 0, 2, or 3 zones*
- Available Peripheral Power: 120mA, 24V

* Available only on dimming models.

Ordering Information

Part #	20A Power Circuits	0-10V Control Circuits	Control Input Voltage
mZb00-102	2	0	120 or 277VAC
mZd20-102	2	2	120 or 277VAC
mZd30-101	1	3	120 or 277VAC
mZb00-Co2	2	0	120 or 347VAC
mZd20-Co2	2	2	120 or 347VAC
mZd30-Co1	1	3	120 or 347VAC

Leviton Manufacturing Co., Inc. Lighting & Energy Solutions

©2013 Leviton Manufacturing Co., Inc. All rights reserved. Subject to change without notice.

6700180/10.0th