

LR8101 LR8102

HIOKI

Startup Guide

DATA LOGGER



EN

Oct. 2025 Revised edition 2
LR8102A965-02



Contents

Introduction.....	5	3.3	Resetting the Instrument	45
Checking Package Contents.....	6	3.4	Using Logger Utility	46
Optional Equipment (Sold Separately).....	7	3.5	Remotely Operating the Instrument through the HTTP Server	47
Symbols and Abbreviations.....	8		Connecting a PC to the HTTP server.....	47
Safety Information	9		Configuring LAN settings.....	48
Precautions for Use.....	10			

1 Overview 13

1.1	Product Overview	13
	Common features to LR8101 and LR8102	13
	Features applicable to LR8102 only.....	13
1.2	Part Names and Functions	14
	LR8101/LR8102 Data Logger.....	14
1.3	Optional Equipment.....	17
	M7100, M7102 Voltage/Temp Module.....	17
	M7103 Power Measurement Module	18
	M1100 AC Power Module.....	20

2 Connection (Preparing for Measurements) 21

2.1	Inspecting the Instrument Before Use	21
2.2	Connecting Measurement Modules	22
2.3	Connecting the AC Adapter.....	24
2.4	Connecting the AC Power Module.....	25
2.5	Connecting Cables.....	27
2.6	SD Memory Card and USB Drive	31
2.7	Turning the Instrument On and Off	32
2.8	Configuring LAN Settings and Connecting the Instrument to LAN.....	33
	Network settings on a PC.....	35
	Connecting the instrument and a PC via LAN.....	36
	Default connection settings for LAN 1	38

3 Settings and Operations 41

3.1	Controlling the Instrument Using Communications Commands.....	41
3.2	Saving and Loading Data.....	44
	Saving data	44
	Loading data.....	44

4 Specifications 49

4.1	Specifications of Data Logger.....	49
4.2	Specifications of Modules	52
	M7100 Voltage/Temp Module	52
	M7102 Voltage/Temp Module	52
	M7103 Power Measurement Module	53
	M1100 AC Power Module.....	53

5 Maintenance and Service 55

5.1	Repair, Calibration, and Cleaning	55
5.2	Troubleshooting	57
	Before returning the instrument for repair.....	57
5.3	Error messages	58
	Error messages	58
5.4	Disposing of the Instrument	63

Warranty Certificate



Introduction

Thank you for choosing the Hioki LR8101/R8102 Data Logger. To ensure that you get the most out of this instrument over the long term, please read this manual carefully and keep it available for future reference.

The LR8102 Data Logger is a model based on the LR8101 with additional functions. See “1.1 Product Overview” (p. 13).

The following instruction manuals are available for this instrument. Refer to appropriate manuals for your specific application. Carefully read the separate document entitled *Operating Precautions* before use.

Type	Description	Format
Startup Guide (this manual)	Information for using the instrument safely, basic operating procedures, and specifications (extracts) are provided.	Hard copy
Instruction Manual (PDF)	Communications commands, which can control the instrument, operating procedures, capabilities, and specifications are provided.	
Operating Precautions	Information for using the instrument safely is provided.	Hard copy
Logger Utility Instruction Manual	Installation and operating procedures of the PC application software are provided.	

<p>Information on download site</p> <p>For details on the product application, the update file for the instrument, and the instruction manual</p> <p>An ISO file is a CD or DVD image file. When double-clicked, it will be recognized as a drive and become available for use.</p>	

Target audience

This manual has been written for use by individuals who use the product or provide information about how to use the product.

In explaining how to use the product, it assumes electrical knowledge (equivalent of the knowledge possessed by a graduate of an electrical program at a technical high school).

Trademarks

- Microsoft, Excel, Microsoft Edge, Visual Basic, and Windows are trademarks of the Microsoft group of companies.
- SD and SDHC Logos are trademarks of SD-3C LLC.
- Intel is a trademark of Intel Corporation or its subsidiaries in the United States and/or other countries.

Internet connectivity

The instrument cannot be connected directly to a service provided by a telecommunications provider (such as a mobile provider, a fixed-line operator, and an Internet provider), including public wireless networks. You must use a router to connect the instrument to the Internet.

Checking Package Contents

When you receive the instrument, inspect it to ensure that no damage occurred during shipment. If you find any damage or discover that the instrument does not perform as indicated in the specifications, please contact your authorized Hioki distributor or reseller.

Check whether the packing contents are correct.

Instrument

LR8101 Data Logger

LR8102 Data Logger

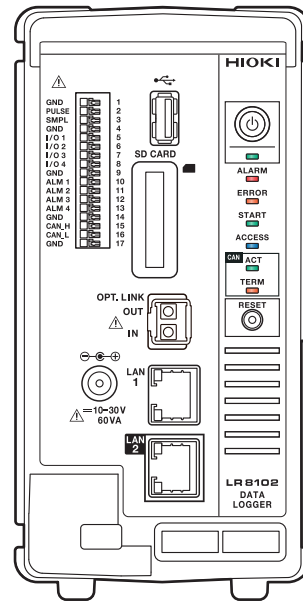
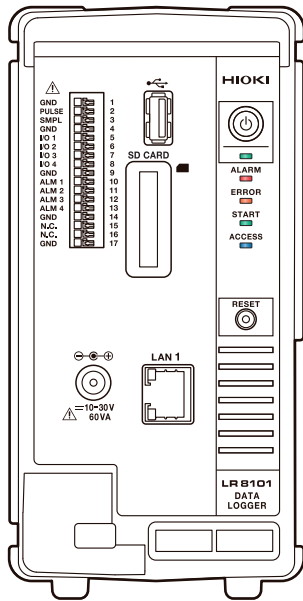

Accessories

Operating Precautions (0990A903)



Startup Guide



PC application software (Logger Utility, CAN Editor and GENECT One) and the instruction manual can be downloaded from Hioki's website.

Optional Equipment (Sold Separately)

The optional equipment listed below is available for the instrument.

To purchase optional equipment, please contact your authorized Hioki distributor or reseller.







Optional equipment is subject to change with no advance notice. Check Hioki's website for the latest information.

M7100	Voltage/Temp Module (15 channels)	
M7102	Voltage/Temp Module (30 channels)	
M7103	Power Measurement Module (3 channels)	
M1100	AC Power Module	
Z1016	AC Adapter (comes with a 3-prong grounded-type [2-pole] power cord.)	
L1012	Power Cable (unterminated)	
Z4001	SD Memory Card (2 GB)	
Z4003	SD Memory Card (8 GB)	
Z4006	USB Drive (16 GB)	
9642	LAN Cable	
L6101	Optical Connection Cable	(1 m)
L6102	Optical Connection Cable	(10 m)





Symbols and Abbreviations

Safety notations



This manual classifies seriousness of risks and hazard levels as described below.

 DANGER	Indicates an imminently hazardous situation that, if not avoided, will result in death or serious injury.
 WARNING	Indicates a potentially hazardous situation that, if not avoided, could result in death or serious injury.
 CAUTION	Indicates a potentially hazardous situation that, if not avoided, could result in minor or moderate injury or potential risks of damage to the supported product (or to other property).
IMPORTANT	Indicates information or content that is particularly important from the standpoint of operating or maintaining the product.
	Indicates a high-voltage hazard. Failure to verify safety or improper handling of the product will lead to an electric shock, burn, or death.
	Indicates a prohibited action.
	Indicates a mandatory action.

Symbols on the product

	Indicates the presence of a potential hazard. See "Precautions for Use" (p. 10) and safety notes listed at the beginning of operating instructions in the instruction manual, and the accompanying document entitled Operating Precautions.
	Indicates that dangerous voltage can be present at this terminal.
	Indicates the push-button switch that can turn the product on and off.
	Indicates a ground terminal.

Symbols for various standards

	Indicates that the product complies with standards imposed by EU directives.
	Indicates that the product is subject to the Directive on Waste Electrical and Electronic Equipment (WEEE) in EU member nations. Dispose of the product in accordance with local regulations.

Safety Information

The instrument and measurement modules have been designed to conform to the international standard, IEC 61010, and thoroughly tested for safety before shipment. However, using the product in a way not described in this manual may negate the provided safety features.

Carefully read the following safety notes before using the instrument and measurement modules.

DANGER



- **Familiarize yourself with the contents of this manual before use.**

Otherwise, the instrument will be misused, resulting in serious bodily injury or damage to the instrument.

WARNING



- **If you have not previously used electrical measuring instruments, ensure adequate supervision by a technician who has experience in electrical measurement.**

Failure to do so may cause the user to experience an electric shock.

It may also cause serious events such as heat generation, fire, or arc flash due to a short-circuit fault.

- **Wear electrically insulating personal protective equipment (PPE).**

Performing measurement using this instrument involves live-line work. Failure to wear PPE could cause the user to experience an electric shock. Using protective gear is prescribed under applicable laws and regulations.

Measurement categories

IEC 61010 defines measurement categories to facilitate safe use of measuring instruments. Test and measurement circuits are classified into three categories according to the type of mains to which they are intended to be connected.

DANGER



- **Do not use a measuring instrument with a lower measurement category rating than that determined according to the type of the mains for measurements on mains.**

- **Do not use a measuring instrument without a measurement category rating for measurements on mains.**

Otherwise, the user will suffer from a serious bodily injury or the instrument and the mains installation will be damaged.

Precautions for Use

Observe the following precautions to ensure safe use of the instrument and effective use of its capabilities.

Use of the instrument should conform not only to its specifications but also to the specifications of all equipment to be used, including accessories and optional equipment.

Checking before connection

DANGER

■ **Inspect the instrument and verify proper operation before use.**



Use of the instrument while it is malfunctioning will result in serious bodily injury. If you find any damage, contact your authorized Hioki distributor or reseller. For inspections, see “2.1 Inspecting the Instrument Before Use” (p. 21).

Installing the instrument

WARNING

■ **Do not use the instrument in locations such as the following:**



- In locations where it would be subject to direct sunlight or high temperatures
- In locations where it would be exposed to corrosive or explosive gases
- In locations where it would be exposed to powerful electromagnetic radiation or close to objects carrying an electric charge
- Close to inductive heating devices (such as high-frequency inductive heating devices and IH cooktops)
- In locations characterized by a large amount of mechanical vibration
- In locations where it would be exposed to water, oil, chemicals, or solvents
- In locations where it would be exposed to high humidity or condensation
- In locations with an excessive amount of dust

Doing so could damage the instrument or cause it to malfunction, resulting in bodily injury.

■ **Install the instrument, leaving enough space around it to unplug the power cord.**



If enough space is left around, the power cannot be shut off immediately in an emergency. Failure to do so could result in bodily injury, fire, or damage to the instrument.

IMPORTANT

Make sure that the ambient temperature around the terminal blocks of the measuring modules does not change. If the terminal blocks blow in the wind from a ventilation fan or an air conditioner during temperature measurements using thermocouples, measurement errors may occur.

If the ambient temperature changes significantly, wait at least 60 minutes after stabilization before starting measurements.

- Do not block the vents. (Leave at least 3 cm of space on the top and the right, and at least 10 cm on the rear to keep the instrument's temperature from rising.)
- Do not stack the instruments.

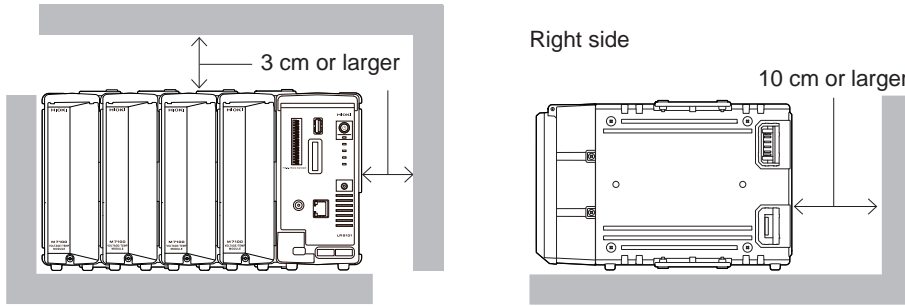

Precautions during measurement

⚠ DANGER

- Do not apply voltages exceeding the following rated voltages of the measuring modules across a channel and another: the maximum input voltage, the maximum rated line-to-ground voltage, the maximum rated inter-channel voltage, or the maximum rated inter-module voltage.



- Maximum input voltage: acceptable highest voltage across the positive and negative terminals
- Maximum rated inter-channel voltage: acceptable highest voltage across any channels in a module
- Maximum rated line-to-ground voltage: acceptable highest voltage across the ground and an input terminals
- Maximum rated inter-module voltage: acceptable highest voltage across a channel of a module and that of another module

Doing so will result in bodily injury or damage to the instrument. These rated voltages differ according to the measurement module model. You can find them on “4 Specifications” (p. 49).

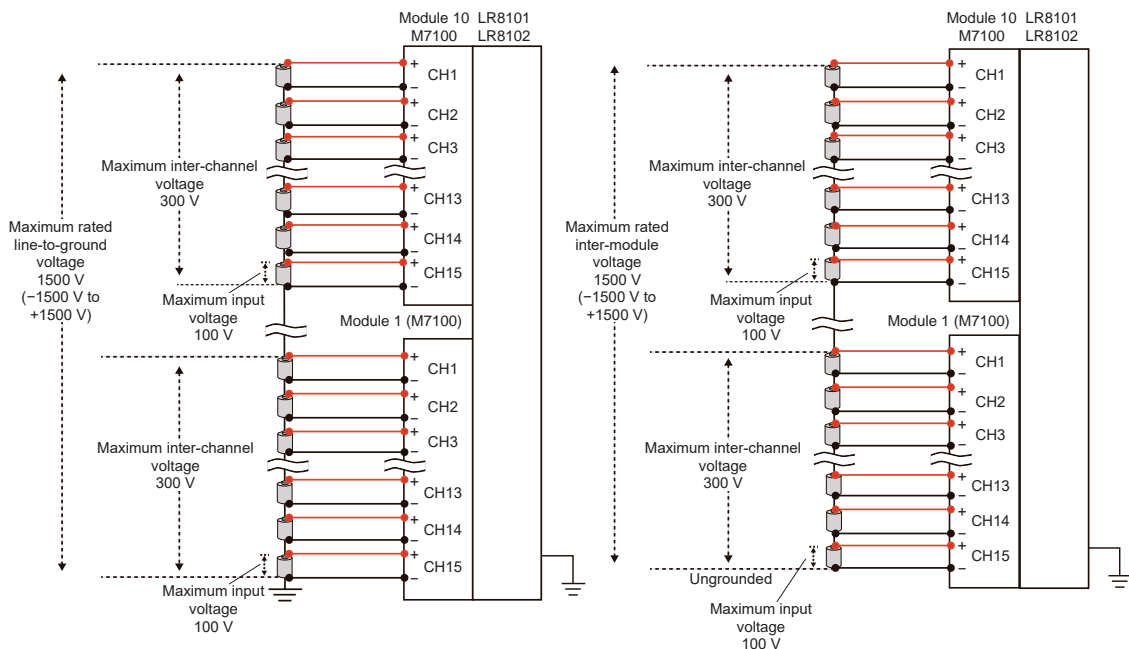



Supplementary explanation on maximum inter-channel voltage

When a module has the maximum inter-channel voltage of 300 V, keep the potential difference not only across any adjacent two channels but also across any two channels within 300 V. For example, the potential difference not only across CH1 and CH2 but also across CH1 and CH15 must be within 300 V.

DANGER

- **Do not use the instrument for measurements on circuits that exceed ratings or specifications of the instrument.**

Doing so will cause damage to the instrument or overheating, resulting in serious bodily injury.



- **Do not use the instrument and measurement modules to make measurement on the mains circuit.**

Although the measurement modules M7100 and M7102 have a CAT II-compliant line-to-ground voltage, they cannot be used for measurement requiring equipment with a measuring circuit rated for CAT II, CAT III, or CAT IV.

Never apply a voltage from a mains installation requiring equipment with a measuring circuit rated for CAT II, CAT III, or CAT IV across any measurement terminals.

Doing so will cause the user to experience an electric shock or damage the instrument.

WARNING

- **Do not get the instrument wet.**



- **Do not operate the instrument with wet hands.**

Doing so could cause the user to experience an electric shock.

- **Securely connect the measuring cables to the input terminals.**

Loose terminals could increase contact resistance and cause the instrument to overheat, resulting in bodily injury, instrument burnout, or fire.



- **Attach the connector covers when a measuring module is not connected.**

Failure to do so could cause the user to experience an electric shock or damage to the instrument and measurement modules.

1 Overview

1.1 Product Overview

This instrument, a multichannel data logger that can be combined with individual measuring modules, is used for recording physical readings, including temperatures and voltages.

Common features to LR8101 and LR8102

● Choice of measurement modules according to applications

Feature	Module
Allows the instrument to record voltage readings at intervals of 5 ms with the maximum rated line-to-ground voltage of 1500 V.	M7100 Voltage/Temp Module
Allows the instrument to record temperature readings through 30 channels.	M7102 Voltage/Temp Module
Allows the instrument to record power with a high degree of precision	M7103 Power Measurement Module (the instrument requires the firmware version 1.50 or later to be installed)

● Up to 10 measurement modules can be connected.

A single instrument can accommodate up to 10 measurement modules, with the exception that only up to four M7103 modules can be connected. Additionally, it can accommodate one power supply module.

Features applicable to LR8102 only

● Data output based on the User Datagram Protocol (UDP)

The instrument can output measured data for every sampling in real time at intervals of 5 ms at the fastest. This is useful when real-time processing, such as hardware in-the-loop simulation (HILS) can provide, is required.

● Multiple instruments synchronized for measurement

Using the optional L6101 Optical Connection Cable (1 m) or L6102 Optical Connection Cable (10 m) allows multiple instruments to make synchronous measurement. The primary instrument can output measured data acquired by all the synchronized instruments from its LAN 2 port.

● Data output based on the controller area network (CAN) protocol.

The instrument can output measured values based on the CAN protocol. Output data can be used for data integration with information of in-vehicle devices, such as battery management systems (BMS).

1.2 Part Names and Functions



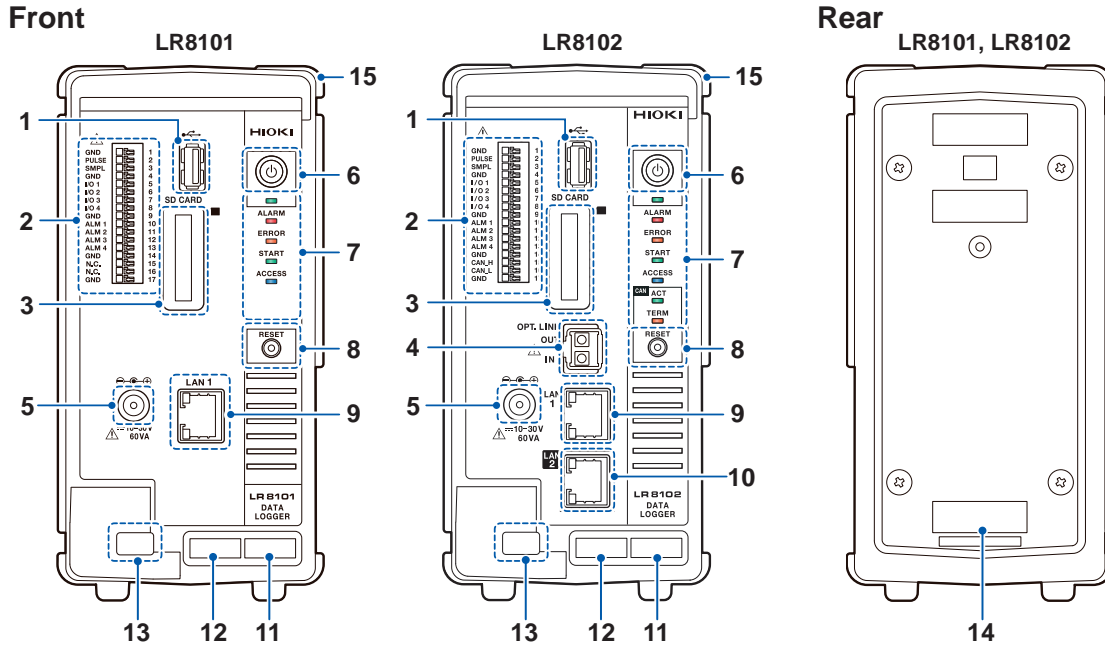



LR8101/LR8102 Data Logger



No.	Name	Function
1	USB connector	Used to an optional USB Drive.
2	External control terminals	Used to control the instrument with external signals. Alarm signals can be output from this terminal.
3	SD card slot	Used to insert an optional SD Memory Card.
4	Optical synchronization connector*1	Used to connect an optional optical connection cable.
5	Power supply terminal	Used to connect an optional Z1016 AC Adapter. An external power supply (10 V to 30 V DC) can be connected.
6	Power key	Press to turn the instrument on and off.
7	LEDs	See the next page.
8	RESET key	Press to reset the instrument. Press to recover the instrument from warning states.
9	LAN 1 port	Used to connect a LAN cable. (100BASE-TX/1000BASE-T)
10	LAN 2 port*1	Used to connect a LAN cable. (100BASE-TX/1000BASE-T)
11	MAC address (LAN 1)	Indicates the MAC address assigned to LAN 1. Do not remove this sticker because the number is important.
12	Serial number	For the latest information, check Hioki's website. Do not remove this sticker because the number is required for product tracking. Share this number when contacting your reseller.
13	Cable hook	Used to tuck the AC adapter cable into this hook to prevent it from coming off.

No.	Name	Function
14	MAC address (LAN 2)* ¹	Indicates the MAC address assigned to LAN 2. Do not remove this sticker because the number is important.
15	Connection cover	When using the instrument without connecting a module, install the connector cover.

Key	Function	Operation
Power key	Shutdown	Press once. The four LEDs below the power LED start flashing (approx. 5 s). Press again while the LEDs are flashing to turn the instrument off.
RESET key	Full reset	Hold down while turning the instrument on to reset it completely. Hold down until the four LEDs below the power LED flash on and off and a buzzer sounds.
	Recovery from warning state	Press once while the instrument is in the warning state (the ERROR LED lights up) to recover it.
	Clearing latched alarm	Press once to clear latched alarms.

LED	Name	Function
	Power	The instrument has been turned on.
	ALARM	An alarm has been issued.
	ERROR	Blink: An error has occurred. On: A warning has occurred.
	START	The instrument is making a measurement.
	ACCESS	The instrument is accessing the SD Memory Card or USB Drive.
	ACT* ¹	The instrument is outputting CAN signals.
	TERM* ¹	The CAN terminator resistor has been turned on.

*1. LR8102 only

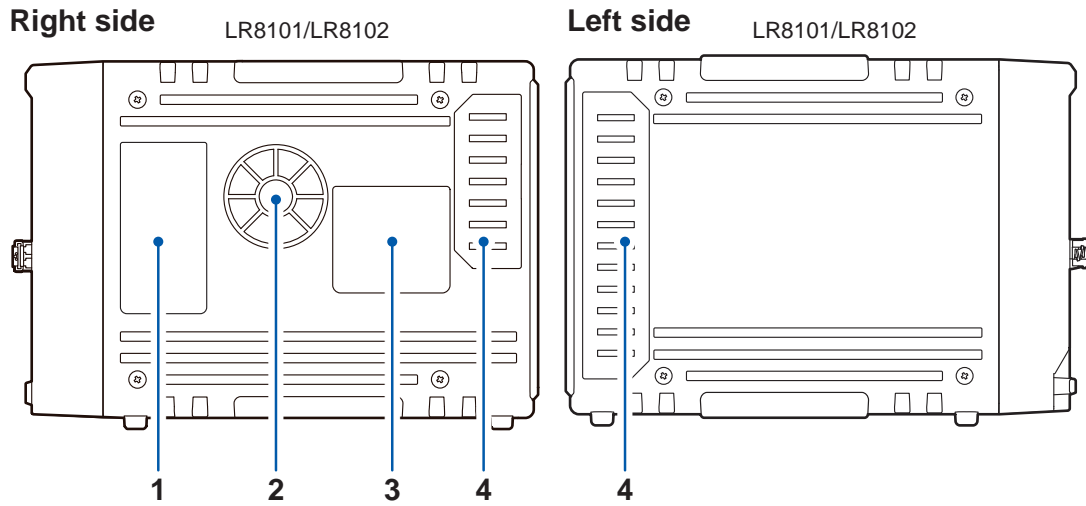

No.	Name	Function
1	LED description	Describes what the LEDs on the front of the instrument indicate.
2	Vents	Used to ventilate the instrument to prevent the inside temperature from rising excessively.
3	Warning	Provides the important information of the instrument.
4	Connector cover	Under the cover, there are connectors to connect a module. When using the instrument without connecting a module, install the connector cover.

1.3 Optional Equipment

Product name		Measurable physical quantity	Number of channels	Shortest sampling interval
M7100	Voltage/Temp Module	Voltage, temperature (using thermocouple)	15	5 ms*1
M7102	Voltage/Temp Module	Voltage, temperature (using thermocouple)	30	10 ms*2
M7103	Power Measurement Module	Power (voltage, current)	3	5 ms*3

*1. Only when eight or fewer channels in a module and the voltage range are used.

*2. Only when 15 or fewer channels in a module are used.

*3. Harmonic operations excluded.

M7100, M7102 Voltage/Temp Module

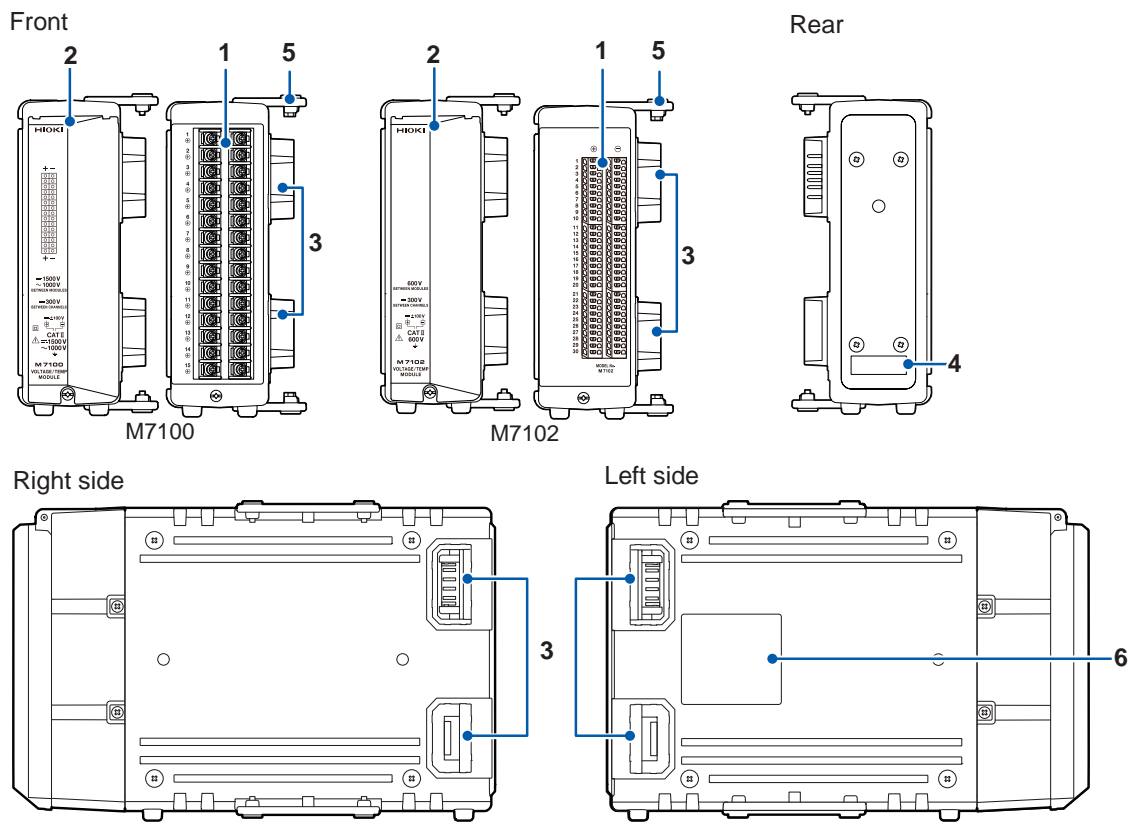

No.	Name	Function
1	Input terminal	The input terminal for each channel. The number represents the channel number.
2	Terminal block cover	The cover protects the terminal block. Close the cover during the measurement.
3	Connector	The connector for measurement module extension. Install the connector cover on the connector when it is not used.
4	Serial number	For the latest information, check Hioki's website. Do not remove this sticker because the number is required for product tracking. Share this number when contacting your reseller.





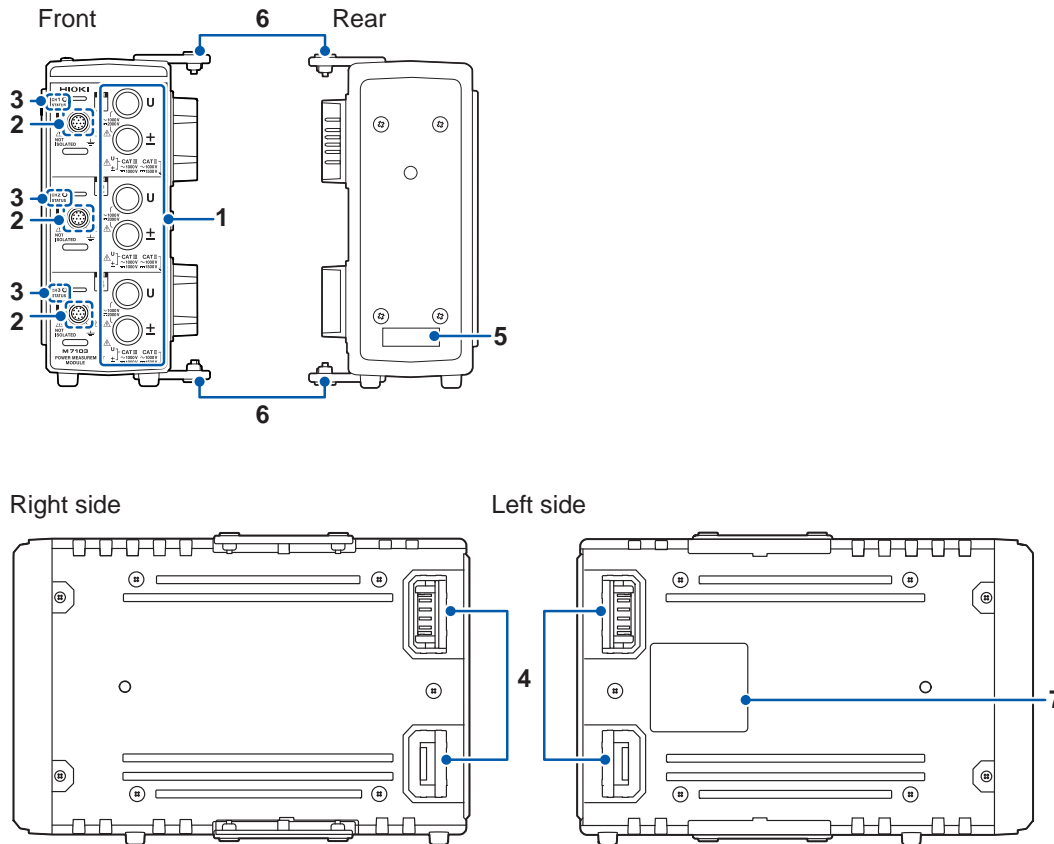

No.	Name	Function
5	Connecting plate	The plate for connecting the measurement modules. After connecting the modules, fix the plate using screws.
6	Warning	Provides the important information of the instrument.

M7103 Power Measurement Module



No.	Name	Function
1	Voltage input terminal	The optional voltage cords from Hioki can be connected.
2	Current sensor terminal	A voltage output type sensor, such as the current probe and CT, can be connected.
3	Status LED	Indicates the operation status of the instrument. (p. 19)
4	Connector	The connector for measurement module extension. Install the connector cover on the connector when it is not used.
5	Serial number	For the latest information, check Hioki's website. Do not remove this sticker because the number is required for product tracking. Share this number when contacting your reseller.
6	Connecting plate	The plate for connecting the measurement modules. After connecting the modules, fix the plate using screws.
7	Warning	Provides the important information of the instrument.

Status LED

LED status	Target	Notification summary	Action
 Rapidly blinking in red* ¹	All channels	Fan error	Check the error message or warning message. See "5.3 Error messages" (p. 58).
 Slowly blinking in red* ²	Relevant channel	Current sensor error	
 Lit in red	Relevant channel	<ul style="list-style-type: none"> • Current or voltage peak over • Current or voltage over load • Power over load 	
 Rapidly blinking in green* ¹	Relevant channel	Harmonic measurement items cannot be measured accurately. <ul style="list-style-type: none"> • Harmonics synchronization unlock • Outside of harmonics frequency range 	Check if the input signal frequency falls within the spec range.
 Slowly blinking in green* ²	Relevant channel	Synchronization unlock	Check the synchronous source setting. Check the voltage range and current range settings Check the zero-cross filter setting Check the LPF setting
 Lit in green	Relevant channel	Normal	—

*1. Repeats blinking five times per second.

*2. Repeats blinking two times per second.

M1100 AC Power Module

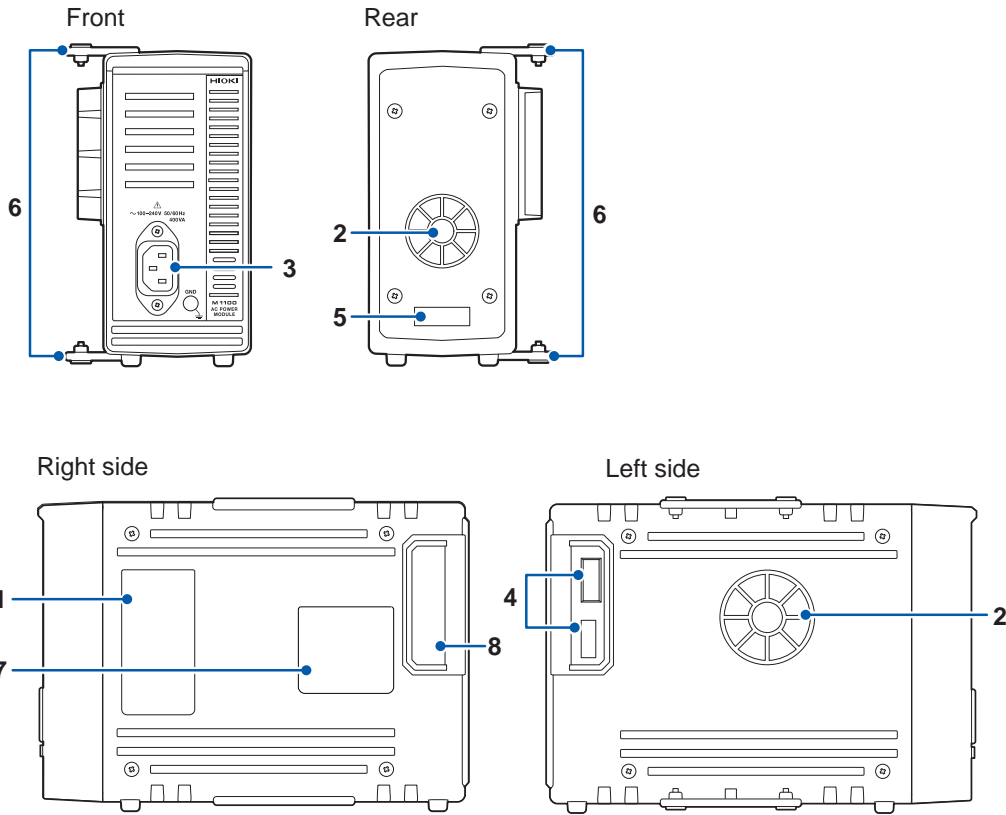

No.	Name	Function
1	Description of the LED	Indicates the operation of the LED located at the front of the instrument.
2	Air vent	Ventilates the instrument to prevent the temperature of the inside from going up excessively.
3	Power inlet	The provided power cord can be connected.
4	Connector	The connector for the instrument.
5	Serial number	For the latest information, check Hioki's website. Do not remove this sticker because the number is required for product tracking. Share this number when contacting your reseller.
6	Connecting plate	The plate for connecting the measurement modules. After connecting the modules, fix the plate using screws.
7	Warning	Provides the important information of the instrument.
8	Opening	The connector cover of the LR8101/LR8102 can be attached.

2

Connection (Preparing for Measurements)

Read "Precautions for Use" (p. 10) carefully before starting to prepare for measurement.

2.1 Inspecting the Instrument Before Use

DANGER

- Before using the instrument, check the measurement cables to confirm that the insulation is not worn and no metal parts are exposed.



- Inspect the instrument and verify proper operation before use.

Using a damaged measurement cable or a damaged instrument will result in serious bodily injury. If you find any damage, replace them with those specified by Hioki.

Inspect the instrument before turning it on to make sure no damage has occurred during storage or shipping.

If you find any damage, contact your authorized Hioki distributor or reseller.

Inspecting the peripheral devices

The insulation of the measurement cables to be connected is not worn and no metal parts are exposed from them.

Do not use a measurement cable if you find any damage. Failure to do so will cause the user to experience an electric shock. Replace with those specified by Hioki.

Inspecting the instrument

- The instrument is not damaged.
If you find any damage, request repair.
- The power LED lights up after the instrument is turned on.
If the LED does not light up, the power cord may have a break or the instrument may be damaged. Request repair.

2.2 Connecting Measurement Modules

Up to 10 optional measurement modules can be connected to a single instrument.

The instrument can accommodate a combination of up to ten M7100 and M7102 modules in total.

It can accommodate up to four M7103 modules.

When using the M7103 modules, the M1100 AC Power Module is required.

The M7100 or M7102 cannot be placed between the M7103 and the instrument.

WARNING



- **Do not remove the connector covers when the instrument or a measurement module is used without another measurement module connected.**

Doing so could cause the user to experience an electric or damage to the instrument and measurement modules.



- **Turn the instrument off and remove the measurement cables before connecting/removing measurement modules.**

Failure to do so could cause the user to experience an electric or damage to the instrument and the measurement modules.

You will need: Phillips screwdriver (No. 2)

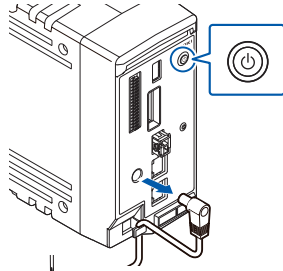

1 Turn the instrument off and remove the AC Adapter.

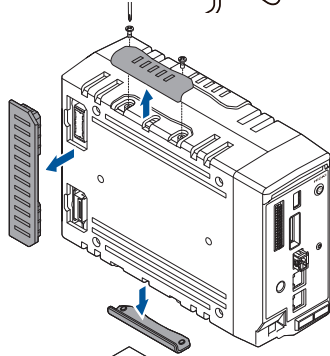

2 Remove the cover.

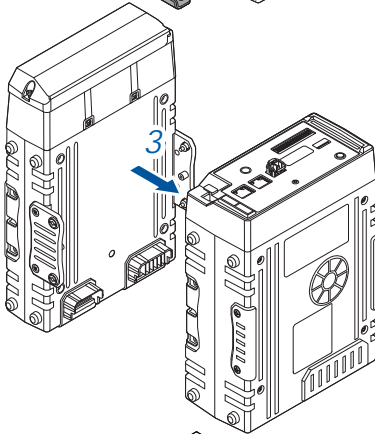

3 Connect the measurement module to the connectors of the instrument.

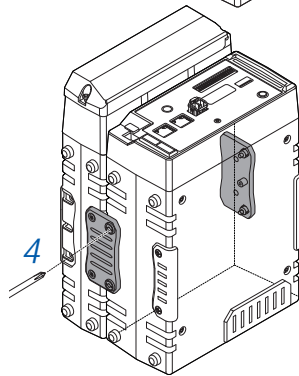

4 Tighten the four captive screws to 0.6 N•m.

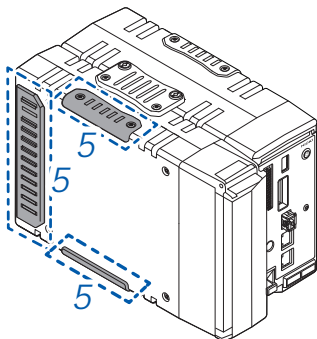

5 Reattach the covers removed in step 2.

2.3 Connecting the AC Adapter

Connect the power cord to the AC adapter and plug it into the outlet.

Make sure to use the optional Z1016 AC Adapter (comes with a 3-prong grounded-type [2-pole] power cord).

Before connecting the AC Adapter, make sure to read “Handling cords and cables” (p. 27).

In addition, turn the instrument off before connecting or disconnecting the AC Adapter.

WARNING

- **When supplying the power from the utility power to the instrument, use the optional Z1016 AC Adapter (comes with a 3-prong grounded-type [2-pole] power cord).**

- **Use the AC Adapter at the rated supply voltage and frequency.**

Rated supply voltage: 100 V to 240 V AC (within a voltage fluctuation of $\pm 10\%$)

Rated supply frequency: 50 Hz/60 Hz



- **Turn the instrument off before connecting the AC Adapter to the instrument and the utility power.**

Failure to do so will cause the user to experience an electric shock.

- **Plug the power cord of the AC Adapter into a 3-prong grounded-type (2-pole) power outlet.**

Connecting the power cord to an outlet that cannot ground connected equipment could cause the user to experience an electric shock.

Supply the power to the instrument using the AC Adapter (AC driven)

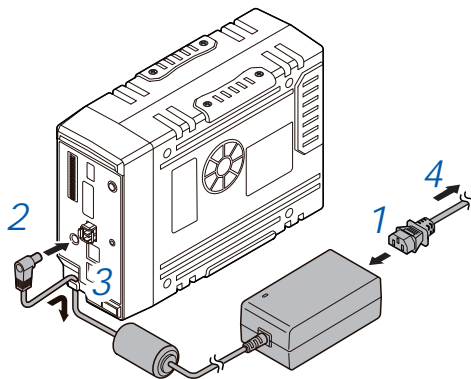

- 1 Connect the power cord to the Z1016 AC Adapter.
- 2 Connect the output plug of the AC Adapter to the power supply terminal of the instrument.
- 3 To prevent the plug from coming off, tuck the output cord of the AC Adapter into the cable hook of the instrument.
- 4 Connect the plug of the power cord to the outlet.

A DC power supply (10 V to 30 V DC) can also be used as an external power supply.

See “2.4 Connecting an External Power Supply” in the Instruction Manual.

2.4 Connecting the AC Power Module

Install the optional AC power supply module M1100 onto the instrument.
The AC power supply module is required only when using the M7103 Power Measurement Module.
Before connecting, make sure to read “Handling cords and cables” (p. 27).
Also, turn off the instrument before connecting the AC power supply module.

WARNING

- Use the AC power supply module at the rated supply voltage and the rated power-supply frequency.

Rated supply voltage: 100 V to 240 V AC (voltage fluctuation within $\pm 10\%$)

Rated power-supply frequency: 50 Hz/60 Hz



- Turn off the instrument before connecting the AC power supply module to the instrument and the commercial power supply.

Failure to do so could cause the operator to experience an electric shock.

- Connect the power cord of the AC power supply module to a 3-prong grounded-type (2-pole) power outlet.

Connecting the power cord to an ungroundable outlet could cause the operator to experience an electric shock.

CAUTION



When using the AC power supply module, do not use the AC adapter or external power supply.

- Before connecting the plug to the outlet, connect the output plug of the AC power supply module to the instrument.



Failure to do so could damage the instrument.

- When unplugging the power cord from the outlet or instrument, pull on the plug (not the cord).

The cable may be broken or the output terminal may be damaged.

Connecting the AC power supply module to the instrument

Applicable module: M1100

Required items: Phillips screwdriver (No. 2)

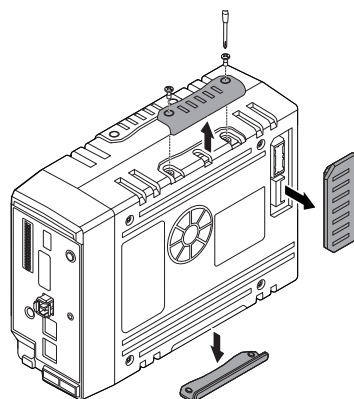

- 1 Remove the connector cover.
- 2 Loosen the four captive screws.

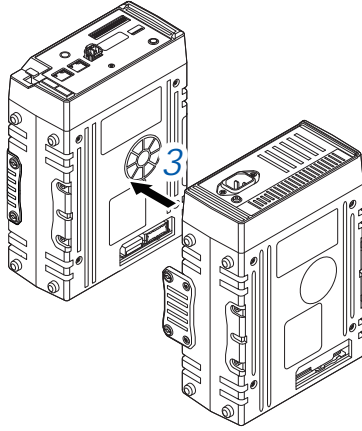

- 3 Connect the AC power supply module to the connector of the instrument.

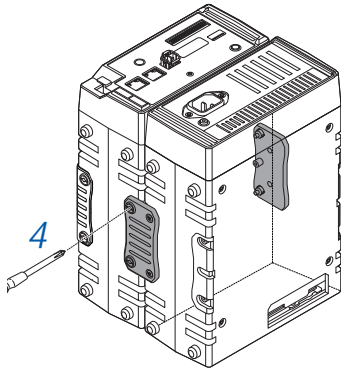

- 4 Tighten the four captive screws.
Tighten the screws at 0.6 N•m.

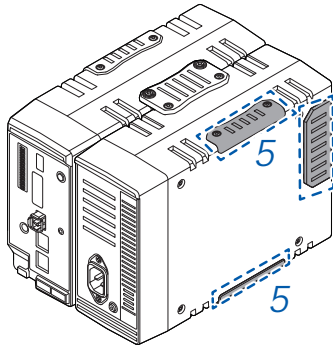

- 5 Reattach the connector cover removed in step 1.
Tighten the screws at 0.6 N•m.

Supplying the power to the instrument using the M1100 AC power supply module (AC driven)

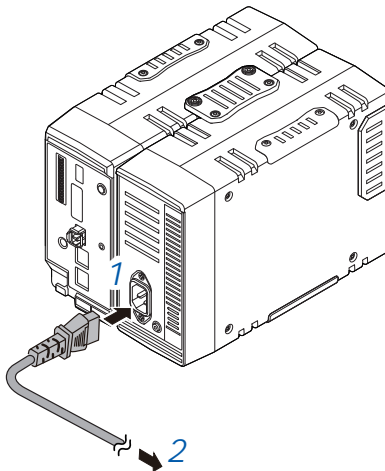

- 1 Connect the provided power cord to the power inlet of the AC power supply module.
- 2 Connect the plug of the power cord to the outlet.

2.5 Connecting Cables

Handling cords and cables

WARNING

- **Hang the measurement cables lower than the instrument.**

Otherwise, water or liquid could enter the instrument along the measurement cables, damaging the instrument and causing bodily injury.

- **Follow the procedure below before connecting cables to the measurement terminals or turning the instrument on:**

1. Shut down the power of the lines to be measured.
2. Turn the instrument off and other equipment.
3. Remove the cables from the objects to be measured
4. Close the terminal block cover.



- **Use specified cabling materials only. Alternatively, use cabling materials that provide sufficient dielectric strength and current capacity.**

Failure to do so could result in an electric shock or a short-circuit fault.

- **Securely connect the measurement cables to the input terminals.**

Increasing contact resistance due to loose terminals could cause the instrument to become hot, resulting in bodily injury, burn damage to the instrument, or fire.

Connecting input cables to the input terminals

DANGER

- **Do not leave the input cables connected in an environment where surges exceeding the dielectric strength can occur.**

Doing so will damage the instrument, resulting in serious bodily injury.



WARNING

- **Follow the procedure below before connecting cables to the input terminals:**

1. Turn the instrument and the equipment off to be connected.
2. Discharge static electricity from your body.

Failure to do so could cause the user to experience an electric shock or damage the instrument.



Connecting input cables to the input terminals

DANGER



- **Do not leave the input cables connected in an environment where surges exceeding the dielectric strength can occur.**

Doing so will damage the instrument, resulting in serious bodily injury.

WARNING

- **Follow the procedure below before connecting cables to the input terminals:**



1. Turn the instrument and the equipment off to be connected.
2. Discharge static electricity from your body.

Failure to do so could cause the user to experience an electric shock or damage the instrument.

Connecting cables to the screw-type terminal block

WARNING



- **Use the dedicated screws to fix cables to a screw-type terminal block.**

Using screws other than the dedicated ones could cause the user to experience an electric shock or damage the instrument.

Connecting wires to the external control terminals

WARNING



- **Follow the procedure below before connecting wires to the external control terminals:**

1. Turn off the instrument and the equipment to be connected.
2. Discharge static electricity from your body.
3. Check that the signals do not exceed the external input and output ratings.
4. Properly isolate the instrument and the equipment to be connected from each other.

Failure to do so could cause the user to experience an electric shock or damage the instrument.

Connecting the CAN cable (LR8102 only)

WARNING



- **Turn every equipment off before connecting and disconnecting interface connectors.**

Failure to do so could cause the user to experience an electric shock.

Connecting the Optical Connection Cable (LR8102 only)

CAUTION

- **Do not connect or disconnect the connector while the instrument has been turned on.**



Doing so could damage the instrument.

- **Do not bend or pull the Optical Connection Cable.**

Doing so could break the cable or damage the insulation, causing the instrument to malfunction.

Connecting the voltage cords

DANGER

- **Do not short-circuit the two wires of the measurement line using the metallic part at the tip of the voltage cord clip.**



Doing so can cause arc flash, resulting in serious bodily injury or damage to the device or other equipment.

WARNING

- **When using the instrument, make sure to use the connection cord specified by our company.**



Using any cords other than that specified could result in serious bodily injury or short circuit.

Connecting the current sensor (current input)

DANGER

- **Do not use the current sensor for measuring any circuits that exceed the maximum rated line-to-ground voltage.**



- **Do not use over bare conductors.**

Doing so could result in serious bodily injury or short circuit.

For the maximum rated line-to-ground voltage of the current sensor, see the instruction manual supplied with the current sensor.

WARNING

- **Be sure to turn OFF each hardware before connecting the pass-through type current sensor, such as CT6875.**



Failure to do so could cause the operator to experience an electric shock or short circuit.

CAUTION



- **Do not connect or disconnect connectors while the instrument is powered ON.**

The sensor can be damaged.



- **When disconnecting the cable, be sure to release the lock first, and then pull on the connector end (not the cable).**

Failure to do so could cause damage to the BNC connector or joint section.

When a value exceeds the measurement range (VT/CT is used)

DANGER



- **Do not touch any input terminals on the VT (PT), CT, or instrument when they are in operation.**

Doing so could result in serious bodily injury.

WARNING



- **Do not short-circuit the secondary side when an externally installed VT (PT) is used.**

Applying voltage to the primary side while it is short-circuited will cause a large current to flow into the secondary side, potentially resulting in burning or fire.

- **Do not release the secondary side when an externally installed CT is used.**

If current flows into the primary side while the secondary side is released, high voltage will be generated on the secondary side, which could cause the user to experience an electric shock.

2.6 SD Memory Card and USB Drive

To store data, use the following optional equipment:

Z4001 SD Memory Card (2 GB), Z4003 SD Memory Card (8 GB),

Z4006 USB Drive (16 GB)

WARNING



- **Do not modify, disassemble, or repair the SD Memory Card or USB Drive.**

Doing so could cause bodily injury or fire.



- **Keep these products out of reach of children.**

Failure to do so could cause children to swallow an SD Memory Card or USB Drive accidentally.

2.7 Turning the Instrument On and Off

⚠ WARNING



- Before turning the instrument on, make sure that the supply voltage to be used falls within the supply voltage range indicated on the AC Adapter of the instrument.

Supplying a voltage outside the specified range to the AC Adapter could damage the instrument or the AC Adapter, causing bodily injury.

⚠ CAUTION



- Do not apply voltage across input terminals while the instrument has been turned off.

Doing so could damage the instrument.

IMPORTANT

- Always turn the instrument off after use.
- An instantaneous power failure more than 40 ms could turn the instrument off, causing the instrument to malfunction. Check the supplied power state.

How to turn the instrument on

Pressing the power key can turn the instrument on. The power LED lights up in green.

How to turn the instrument off

Press the power key. The four LEDs below the power LED flash for 5 s.

Press the power key again while the LEDs are flashing to turn the instrument off.

The power LED is turned off.

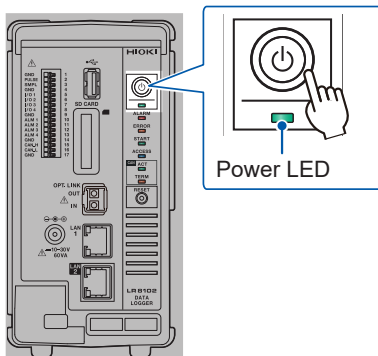

2.8 Configuring LAN Settings and Connecting the Instrument to LAN

The instrument and a PC can be connected using a LAN cable.

IMPORTANT

Be sure to configure the LAN settings before connecting the instrument to the network. If you change the settings while the instrument is connected to a network, the instrument may have the same IP address as another equipment on the LAN, causing incorrect address information to be sent to the LAN.

Making checks before connection

Connecting the instrument to an existing network

First, you have to ask the network system administrator (department) to allocate the following parameters. Ensure that the instrument uses a unique IP address among equipment on the network.

DHCP server	DHCP server: used/not used
Host name IP address Subnet mask	Host name IP address Subnet mask: ____:____:____:____ (An IP address and a subnet mask are not required when the DHCP server is used)
Port	<p>LAN 1 TCP/IP port number to be used: ____X (default setting: 880X) Specify at least the first 3 digits of the 4 or 5 digits. The last digit is reserved by the instrument (The last digit: 0 for Logger Utility, 2 for the communications commands, 5 for XCP on Ethernet) Specify when the default settings of 8800 to 8809 are not available</p> <div style="border: 1px solid black; padding: 5px; margin: 5px 0;"> <p>Example of port number (with 880x default setting) Communication command: 8802 (Use this port for command control) Logger Utility: 8800 XCP on Ethernet: 8805</p> </div> <p>LAN 2 UDP/IP port number to be used: ____X (default setting: 880X) Specify at least the first 3 digits of the 4 or 5 digits. The last digit is reserved by the instrument (The last digit: measured data output, 5 for XCP on Ethernet) Specify when the default settings of 8800 to 8809 are not available</p> <div style="border: 1px solid black; padding: 5px; margin: 5px 0;"> <p>Example of port number (with 880x default setting) Measurement data output: 8801 XCP on Ethernet: 8805</p> </div>
Gateway	Gateway: used/not used IP address (when used): ____:____:____:____ (Setting is not required when the DHCP server is used because the address is obtained from the server.)
DNS	DNS: used/not used IP address (when used): ____:____:____:____ (Setting is not required when the DHCP server is used because the address is obtained from the server.)



When connecting the instrument and a PC one-to-one (local network without external connection)

The following address is recommended if there is no administrator or the setting is discretionary. (Setting example)

DHCP server		Off
Host name		Discretionary setting (must be a unique name)
IP address	PC	192.168.1.1
	Logger 1	192.168.1.2
	Logger 2	192.168.1.3 (numbered consecutively)
Subnet mask		255.255.255.0
Port		880X
Gateway		Off
DNS		Off

Parameter

The Dynamic Host Configuration Protocol server (DHCP server) is used	The DHCP is a set of rules used by devices for automatically acquiring an IP address and other communication parameters and configuring themselves. When the DHCP server is enabled and the server and the instrument are operating on the same network, the instrument can automatically acquire and configure the IP address, subnet mask, and gateway.
Host name	This name represents the instrument on the network. Ensure that the instrument uses a unique name among equipment on the network. The host name setting is not registered in the DNS because the instrument does not support dynamic DNS.
IP address	The IP address identifies individual equipment connected to the network. Ensure that the instrument uses a unique address among equipment on the network. If the DHCP server is enabled, the setting will be configured automatically using the server.
Subnet mask	The subnet mask separates the IP address into the portion indicating the network and that indicating the equipment. Set the subnet mask in the same way as the equipment in the same network. If the DHCP server is enabled, the setting will be configured automatically using the server.
Gateway IP address	<ul style="list-style-type: none"> When connecting the instrument to a network When the PC to be used (communicating device) is on a different network from that with which the instrument is connected, set this parameter to [ON] to specify the equipment that serves as the gateway. When the PC is on the same network, generally use the same setting as the default gateway setting of the PC. When connecting the instrument and a PC one-to-one Set this parameter to [OFF] when they are connected to the same hub. If the DHCP server is enabled, the setting will be obtained from the server.
DNS (Domain Name System)	If the DNS is enabled, the communications partner can be specified with its name instead of its IP address. (The IP addresses are difficult to remember because they are a series of numbers. It is easier if devices can be specified with their names instead of the IP addresses.) If a server that allows you to obtain the IP addresses using the names is operating on the network, the IP address of the communication partner can be looked up from the name by querying it to the server. If the DHCP server is enabled, the setting will be obtained from the server.



Network settings on a PC

The setting way is the same for the case when connecting the instrument and a PC one-to-one and the case when connecting a PC and multiple instruments via a hub.

The following network is assumed here:

- IP address: 192.168.1.0/24 (network address)
or 192.168.1.1 (private IP address*¹)
- Subnet mask: 255.255.255.0

*1. You may set the IP address as desired: however, a private IP address is recommended.

For Windows 10 or Windows 11

- 1 Display the network connections from [Control Panel] > [Network and Sharing Center] > [Change adapter settings].
- 2 Right-click the icon of the adapter to be used for communications (such as [Local Area Connection] and [Ethernet]), and then select [Properties].
- 3 Select [Internet Protocol Version 4 (TCP/IPv4)], and then click [Properties].

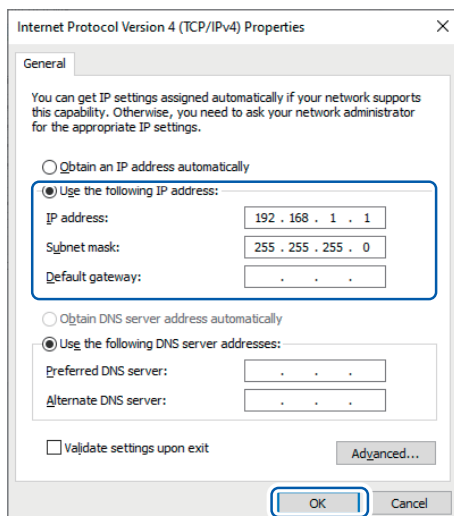
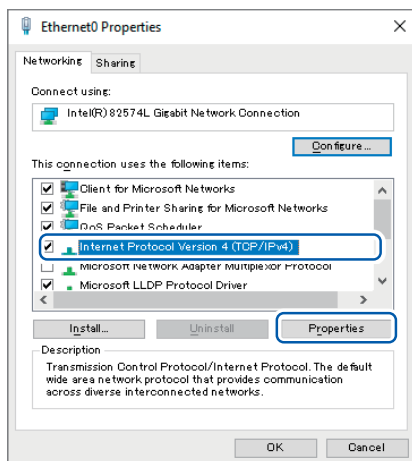

- 4 Enter the IP address and subnet mask in the [IP address] and [Subnet mask] boxes, respectively, then click [OK].

Connecting the instrument and a PC via LAN

Connect the instrument and a PC with a LAN cable.

⚠ CAUTION



- **Do not unplug the LAN cable while the instrument is sending or receiving data.**

Doing so could damage the instrument and the PC.



- **Turn the instrument and PC off before connecting or disconnecting a LAN cable.**

Failure to do so could damage the instrument and the PC or cause them to malfunction.

- **Use the same ground for the instrument and the PC.**

If a LAN cable is connected to the instrument with a potential difference between the ground circuits of the instrument and the PC, the instrument and PC could be damaged or malfunction.

- **If routing a LAN cable outdoors or over more than 30 m, attach a LAN surge protector or other suitable protective device.**

Failure to do so could cause damage to the instrument due to increased susceptibility to the effects of induced lightning.

LAN port of the instrument

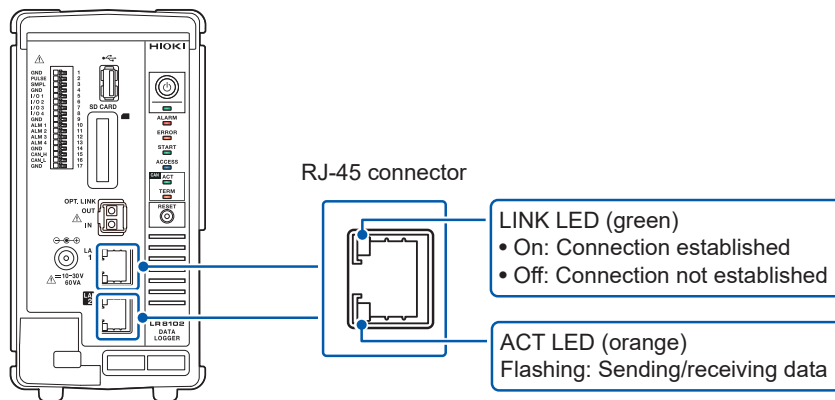

The LINK LED lights up when the instrument is properly connected to the network and available. If the LED does not light up, the instrument or connected devices may have a problem or the LAN cable may have a break.

When connecting the instrument and a PC one-to-one

You will need: 9642 LAN Cable (one)

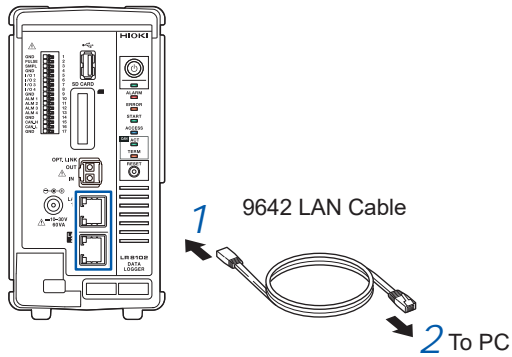

- 1 Connect the 9642 LAN Cable to the LAN 1 or LAN 2 port of the instrument.
- 2 Connect the 9642 LAN Cable to the LAN port of the PC.

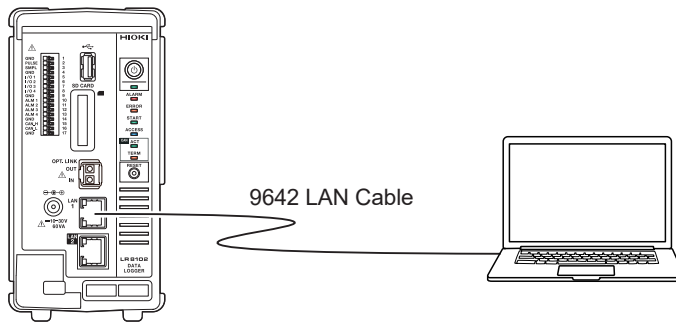

When connecting a single PC and multiple instruments via a hub.

You will need: 9642 LAN Cable (two), hub

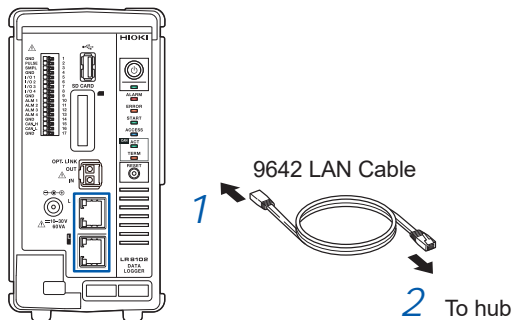

- 1 Connect the 9642 LAN Cable to the LAN 1 or LAN 2 port of the instrument.
- 2 Connect the 9642 LAN Cable to a LAN port of the hub.

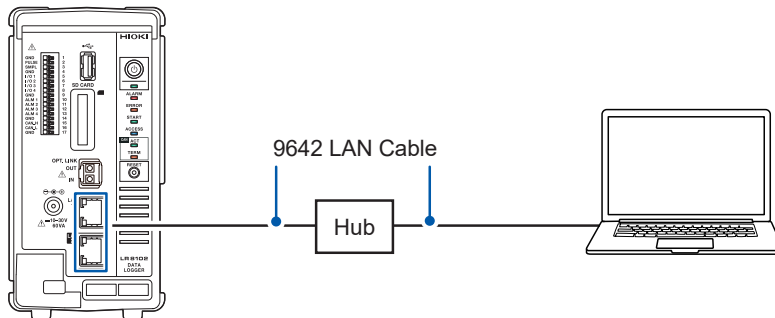

Default connection settings for LAN 1

The instrument has the default LAN 1 IP address of 192.168.1.2.

There are three ways available to change the IP address on LAN 1 and the communication settings of the instrument as follows:

- Using the HTTP server.
- Using the communications commands.
- Using Logger Utility.

To change the settings using the HTTP server

See “3.5 Remotely Operating the Instrument through the HTTP Server” (p. 47)

To change the settings using the communications commands.

Example: Connecting the instrument and a PC one-to-one with the minimum required settings

You will need: 9642 LAN Cable (one), PC with configurable IP address

Change the IP address of the PC to 192.168.1.1

Send the following communications commands from the PC (communications command port 8802)

1 Configure the IP address of the instrument.

The IP address identifies individual equipment connected to the network. Ensure that the instrument uses a unique address among equipment on the network. If the DHCP server is enabled, the setting will be configured automatically using the server.

Setting		
Syntax	Command	<code>:SYSTem:COMMunicate:LAN:IPAddress ip1,ip2,ip3,ip4</code>
Example		<code>:SYSTem:COMMunicate:LAN:IPAddress 192,168,1,100</code> <code>:SYSTem:COMMunicate:LAN:UPDate</code>
Query		
Syntax	Query	<code>:SYSTem:COMMunicate:LAN:IPAddress?</code>
	Response	<code>ip1<NR1>,ip2<NR1>,ip3<NR1>,ip4<NR1></code>
Example		<code>:SYSTem:COMMunicate:LAN:IPAddress?</code> (Response) <code>:SYSTem:COMMunicate:LAN:IPAddress 192,168,1,100</code>
Parameter		
<code>ip1</code>		0 to 255
<code>ip2</code>		0 to 255
<code>ip3</code>		0 to 255
<code>ip4</code>		0 to 255

2 Set the subnet mask of LAN 1.

The subnet mask separates the IP address into the portion indicating the network and that indicating the equipment.

Set the subnet mask in the same way as the equipment in the same network. If the DHCP server is enabled, the setting will be configured automatically using the server.

Setting		
Syntax	Command	<code>:SYSTem:COMMunicate:LAN:SMASk mask1,mask2,mask3,mask4</code>
Example	<code>:SYSTem:COMMunicate:LAN:SMASk 255,255,255,0</code> <code>:SYSTem:COMMunicate:LAN:UPDate</code>	
Query		
Syntax	Query	<code>:SYSTem:COMMunicate:LAN:SMASk?</code>
	Response	<code>mask1<NR1>,mask2<NR1>,mask3<NR1>,mask4<NR1></code>
Example	<code>:SYSTem:COMMunicate:LAN:SMASk?</code> (Response) <code>:SYSTem:COMMunicate:LAN:SMASk 255,255,255,0</code>	
Parameter		
<code>mask1</code>	0 to 255	
<code>mask2</code>	0 to 255	
<code>mask3</code>	0 to 255	
<code>mask4</code>	0 to 255	

3 Update the settings of LAN 1 to reflect.

Setting		
Syntax	Command	<code>:SYSTem:COMMunicate:LAN:UPDate</code>
Example	<code>:SYSTem:COMMunicate:LAN:UPDate</code>	

4 Change the PC to be used or change the IP address of the PC. (as needed)

- If the PC is used only to set the IP address of the instrument, replace the PC.
- Change the IP address of the PC as well if it becomes necessary as a result of setting the IP address of the instrument.

Changing the settings using Logger Utility

You will need: 9642 LAN Cable (one), PC on which Logger Utility can be installed

- 1 **Install Logger Utility on the PC.**
See *Logger Utility Instruction Manual* (PDF file).
See “Information on download site” (p. 5)
- 2 **Start Logger Utility.**
Click **[All Programs] > [HIOKI] > [Logger Utility]**.
- 3 **Click [Setting].**
The settings screen is displayed.
- 4 **Select the [LAN] check box.**
- 5 **Click [Search].**

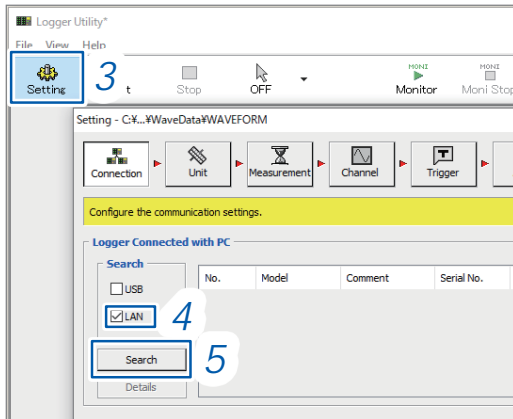

- 6 **Select the target instrument.**
- 7 **Click [Details].**
The **[Detail Information]** dialog box is displayed.



- 8 **Configure the network settings and click [Send].**

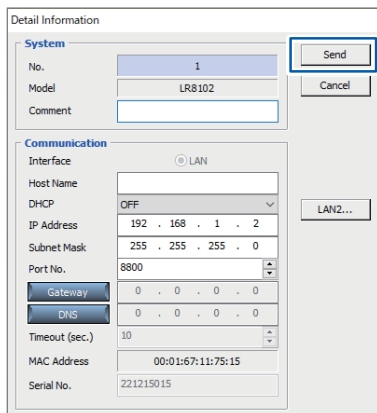

- 9 **Change the IP address of the PC. (as needed)**

3

Settings and Operations

3.1 Controlling the Instrument Using Communications Commands

Before starting measurements, set the measurement conditions using communications commands. By sending communications commands from a PC, you can control the instrument and acquire the states of the instrument.

See “3 Settings and Operations” in the Instruction Manual.

Connect the instrument and a PC with a LAN cable to control the instrument using communication commands.

See “2.8 Configuring LAN Settings and Connecting the Instrument to LAN” (p. 33).

1. Preparing for the product

See “2 Connection (Preparing for Measurements)” (p. 21).

- Install the measurement modules on the instrument.
- Connect the AC Adapter.

2. Preparing for the instrument

See “2.5 Connecting Cables” in the Instruction Manual.

- Connect the LAN cable to the instrument.
- Connect cables such as thermocouples to the terminal blocks of the measurement modules.

3. Turn the instrument on.

See “2.7 Turning the Instrument On and Off” (p. 32).

- Pressing the power key can turn the instrument on.

4. Configuring LAN settings and connecting the instrument to a LAN

See “2.8 Setting and Connecting the LAN” in the Instruction Manual.

5. Configuring instrument settings

See “3.3 Setting Measurement Conditions” in the Instruction Manual.

- Before starting measurements, set the measurement conditions using communications commands.
See “3.1 Controlling the Instrument Using Communication Commands” in the Instruction Manual.
- Set the recording interval (sampling interval) and the recording time.

See “3.4 Setting the Voltage/Temp Module” in the Instruction Manual.

- Set the input types, such as voltage and thermocouples, and ranges.

6. Starting a measurement and stopping it

See “3.9 Starting and Stopping Measurement” in the Instruction Manual.

- Send the **START** command to start a measurement.
- Send the **STOP** command to stop the measurement.

7. Acquiring waveform data

See “4 Acquiring Measurement Data” in the Instruction Manual.

See “Comparison of real-time data acquisition” (p. 43).



Select an appropriate data acquisition method according to the application.



Comparison of real-time data acquisition

	Logger Utility	GENNECT One	Communications command	UDP output	CAN output	XCP on Ethernet	
Shortest sampling period	5 ms	1 s	100 ms	5 ms	5 ms	5 ms	
Number of operable instruments (Number of instruments that can be synchronized for sampling)	5 units	10 units	10 units	10 units	10 units	10 units	
Maximum number of operable channels (number of channels synchronized for sampling)	600 channels (For M7103, up to 30 channels per module)	512 channels	1500 channel (100 ms) Up to 150 channels (5 modules) per unit 3000 channel (200 ms) Up to 300 channels (10 modules) per unit* ⁴	5000 channel 500 channels per unit with the sync setting set to on if data is output all from the primary	100 channel (5 ms) 450 channel (10 ms) 1000 channel (20 ms) (Reference value when data is received using the CAN FD 1 port only)	500 channel (5 ms to 100 ms) (For LAN 1) No limit on number of channels (For LAN 2)	
Output port	LAN 1	✓	✓	✓* ³	-	-	✓
	LAN 2	-	-	-	✓	-	✓
	CAN	-	-	-	-	✓	-
How to obtain the sample program	The latest version available from Hioki's website* ¹		<ul style="list-style-type: none"> The latest version available from Hioki's website*¹ Sequence Maker*² 	The latest version available from Hioki's website* ¹	-	-	

* The number of input channels communication commands can support has been checked under the following environments: The number of channels through which data can be acquired varies depending on the environment

and conditions of use.

Communications commands used to check: `:WAITNextsmpl?`, `:MEMory:TVFETch? MODULE 1` (repeatedly executed the number of times equal to the number of the modules)

Logger (LR8102 with only the recording interval changed from the default settings)

Used PC

OS: Microsoft Windows 10 Pro (Ver. 22H2), CPU: Intel® Core™ i7-9700K 3.60 GHz, RAM: 32 GB

. If the M7103 (up to 293 channels per module) is available, the following number of channels is also possible:

At 100 ms: Up to 293 channels (1 module) per unit.

At 500 ms: Up to 1352 channels (10 modules) per unit.

3.2 Saving and Loading Data

Measurement conditions of the instrument and waveform data can be stored on an SD Memory Card and USB Drives.

IMPORTANT

The operation is guaranteed only for the optional SD Memory Card and USB Drive. Regular operation of any other storage devices is not guaranteed.

Saving data

The two ways are available to save data.
See "6.3 Saving Data" in the Instruction Manual.

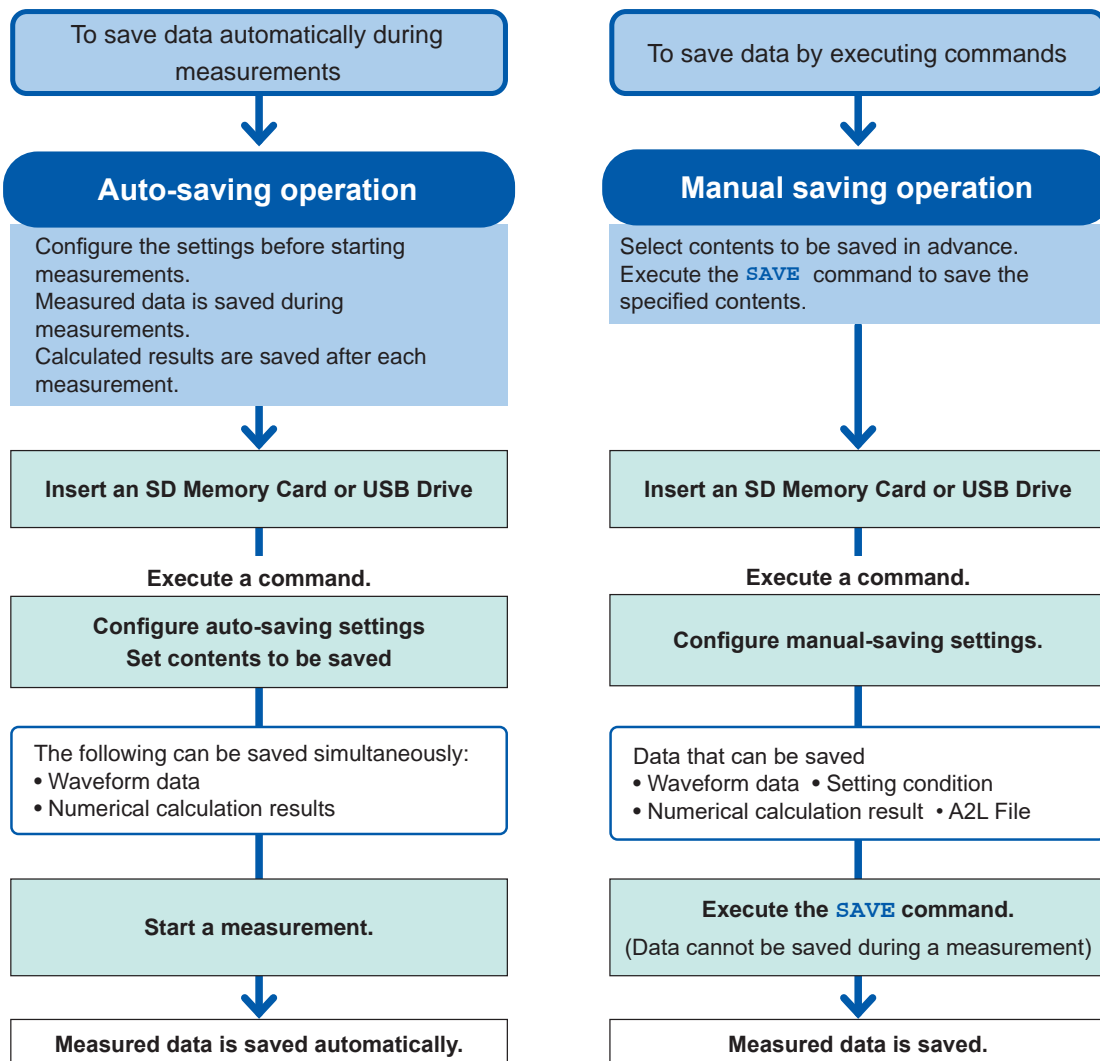

Loading data

The instrument can load setting data saved on storage devices (SD Memory Card or USB Drive).
See "6.4 Loading Data" in the Instruction Manual.

The instrument can load the following files: setting conditions saved with LR8101 or LR8102 and CAN setting files (CES) saved with the PC application (CAN Editor).

3.3 Resetting the Instrument

This section describes how to reset the instrument. There are the following reset types available.

Type	Description
Measured data reset	Measured data internally saved is reset.
System reset	The settings except the communications settings are reset. Measured data is reset as well.
Full reset	The instrument settings are restored to the factory settings.

Measured data reset

The measured data is cleared.

Setting		
Syntax	Command	<code>:SYSTEM:DATAclear</code>
Example	<code>:SYSTEM:DATAclear</code>	
Note		
It takes a few seconds to clear the waveform data.		

System reset

The settings except the communications settings are reset. Measured data is reset as well.

Setting		
Syntax	Command	<code>*RST</code>
Example	<code>*RST</code>	
Note		
It takes time to process the <code>*RST</code> command.		

Full reset

The instrument settings are restored to the factory settings at the start-up of the instrument.

Hold down the **RESET** key until the four LEDs below the power LED flash and the buzzer sounds at the start-up of the instrument.

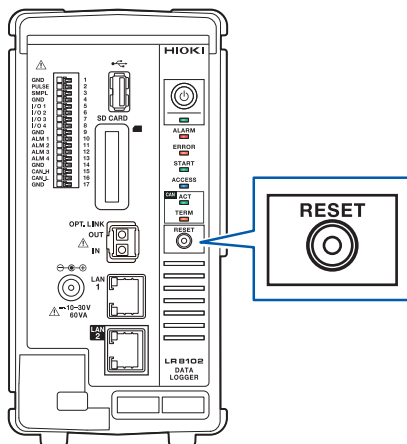

3.4 Using Logger Utility

Using a PC with Logger Utility installed allows you to configure settings, operate the instrument, and observe waveforms.

Please download Logger Utility from Hioki's website.

See "Information on download site" (p. 5)

The PC is connected with the instrument using LAN 1.

The advantages are as follows:

- Data can be acquired in real-time using the PC, allowing you to check waveforms and numerical values immediately.
- Measured data can be analyzed.
- Measured data in binary format can be converted into that in CSV format.
- Waveform data can be transferred in real-time to an Excel file on a PC.
- Up to five loggers, including not only the LR8101/LR8102 but also those you already have, with 600 channels in total are operable.

Logger Utility-compatible models

LR8101, LR8102, LR8450, LR8450-01, LR8400, LR8401, LR8402, LR8410, LR8416, LR8431, LR8432, 8423

For how to install and operate Logger Utility, read the Logger Utility Instruction Manual (PDF). See "Information on download site" (p. 5)

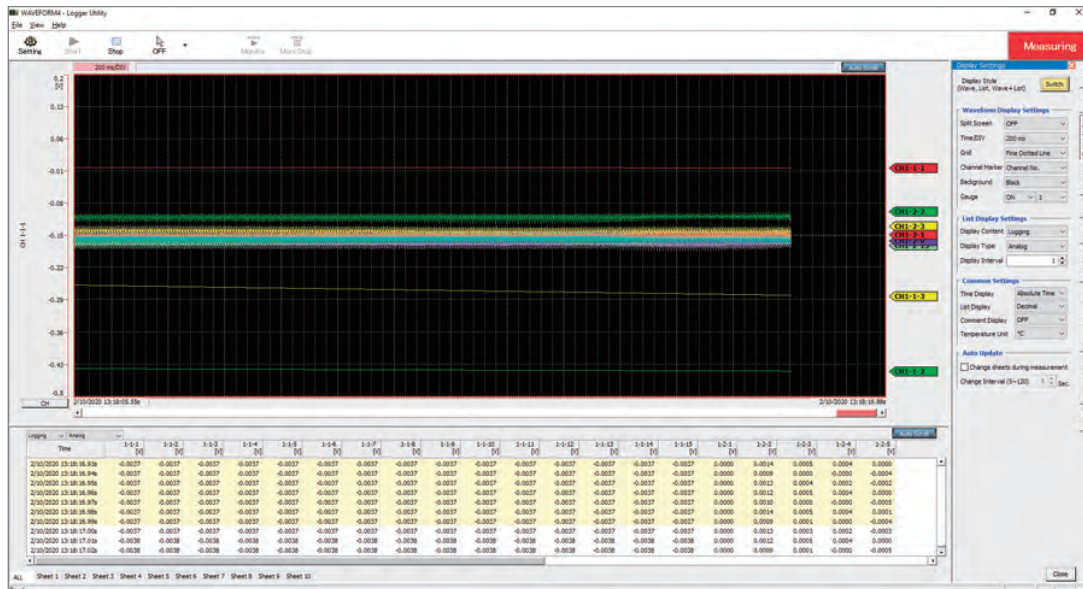

The following restrictions apply to the M7103 Power Measurement Module:

- Up to 30 power calculation channels can be recorded per module.
- MEM files containing power measurement modules cannot be read.

3.5 Remotely Operating the Instrument through the HTTP Server

The instrument can be remotely operated with a PC using the HTTP server function.

You can configure instrument settings and check measured data using familiar web browsers, such as Microsoft Edge.

The LAN settings and connection are required for remotely operating the instrument through the HTTP server.

When the HTTP server is accessed, the header of the communications command settings is set to off. During measurements with Logger Utility or a program, such as one created using Visual Basic, the instrument cannot be remotely operated through the HTTP server.

After the instrument is upgraded, the page of the previous version may open and the operations may not be performed properly. In this case, clear the cache memory of the web browser's and reconnect the PC to the HTTP server.

When you set the clock of the instrument while connecting the HTTP server, the communications may be lost.

Connecting a PC to the HTTP server

This section describes how to connect a PC to the HTTP server.

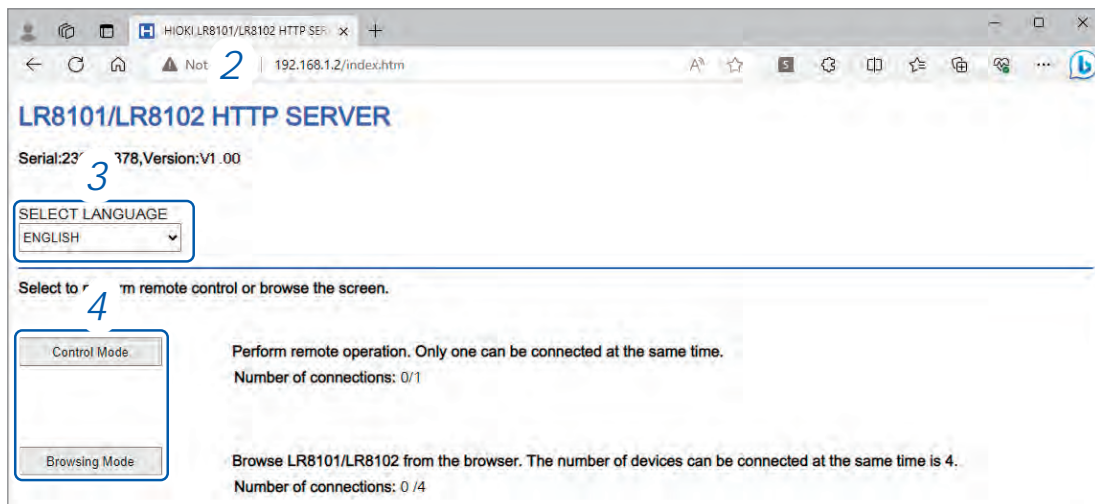

- 1 Start a web browser on the PC.
- 2 Enter the instrument's address in the address bar. (Example: **http://192.168.1.2**)
Using Microsoft Edge is recommended.
- 3 Select a language (as needed).

Japanese, English

- 4 Select the mode.

Control Mode	Allows you to control and set the instrument from a web browser. Only one instrument can be connected at the same time.
Browsing Mode	Allows you to only view screens and states from a web browser. Up to four units can be connected at the same time.

Configuring LAN settings

This section describes how to configure LAN settings using a web browser.

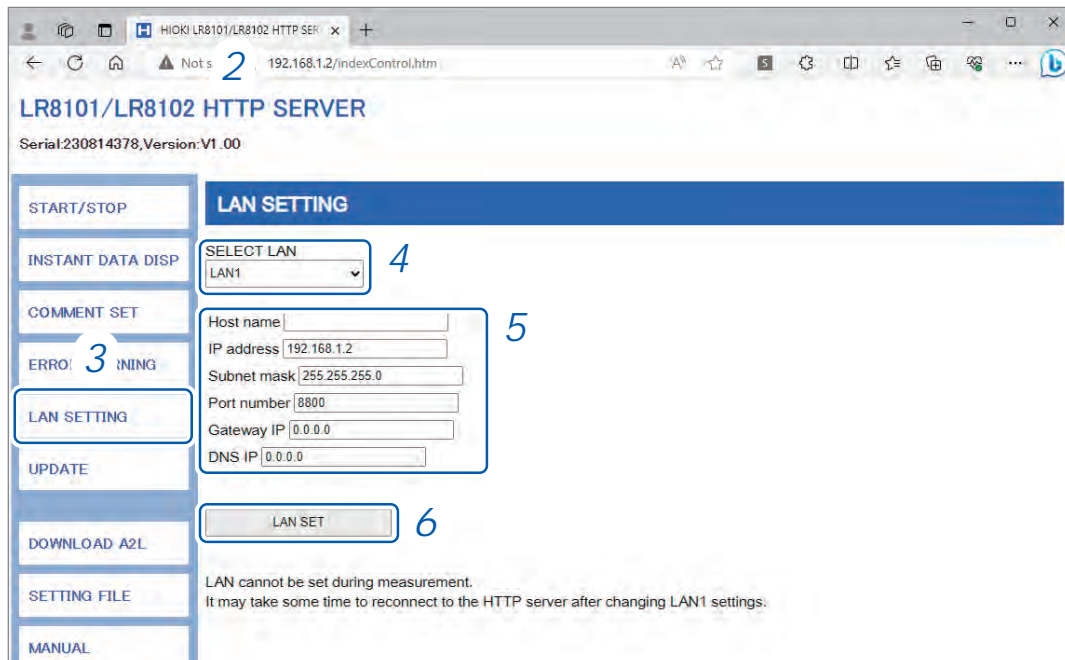

- 1 Start a web browser on the PC.
- 2 Enter the instrument's address in the address bar. (Example: `http://192.168.1.2`)
- 3 Click **[LAN Settings]**.
- 4 Select the type of LAN you want to change.
- 5 Enter the LAN settings in each box.
- 6 Click **[LAN Settings]**

After the LAN 1 settings have been changed, the HTTP server is disconnected. Wait for a while, and then reconnect to the server.

4

Specifications

For details on the specifications, see the Instruction Manual.

4.1 Specifications of Data Logger

Operating environment	Indoor use, pollution degree 2, altitude up to 2000 m (6562 ft.)	
Operating temperature and humidity range	-10°C to 50°C (14°F to 122°F), 80% RH or less (non-condensing)	
Storage temperature and humidity range	-20°C to 60°C (-4°F to 140°F), 80% RH or less (non-condensing)	
Dimensions	With no modules installed Approx. 80W × 166H × 238D mm (3.1W × 6.5H × 9.4D in., excluding protrusions) With one M7100 Voltage/Temp Module installed Approx. 134W × 166H × 263D mm (5.3W × 6.5H × 10.4D in., excluding protrusions) With ten M7100 Voltage/Temp Modules installed Approx. 620W × 166H × 263D mm (24.4W × 6.5H × 10.4D in., excluding protrusions)	
Weight	Approx. 1.5 kg (3.3 lb.)	
Standards	Safety: EN 61010 EMC: EN 61326	
Power supply	AC adapter	Z1016 AC Adapter (supplies 12 V DC ±10%) Rated supply voltage: 100 V to 240 V AC (Assuming voltage fluctuation of ±10%) Rated power-supply frequency: 50 Hz/60 Hz
	Power module	M1100 AC Power Module Rated supply voltage: 100 V to 240 V AC (Assuming voltage fluctuation of ±10%) Rated power-supply frequency: 50 Hz/60 Hz Anticipated transient overvoltage: 2500 V
	External power supply	10 V to 30 V DC
Power consumption	Regular power consumption	When Z1016 AC Adapter or a 12 V DC external power supply is used with one M7100 or M7102 installed: 15 W (instrument only)
	Maximum rated power	When Z1016 AC Adapter is used: 100 VA (including AC adapter) When a 30 V DC external power supply is used: 60 VA (instrument only)

External control terminals Push-button type terminal block

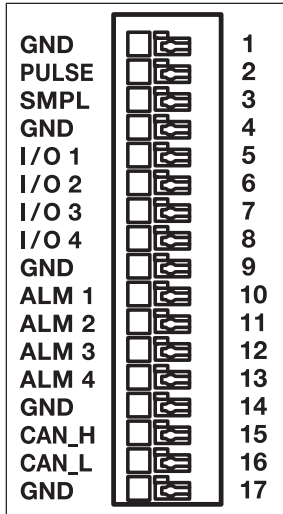

Pin	Signal name	I/O	Function
1	GND	—	Ground
2	PULSE	In	Pulse/logic input
3	SMPL	In	External sampling input
4	GND	—	Ground
5	I/O 1	In/out	External I/O 1
6	I/O 2	In/out	External I/O 2
7	I/O 3	In/out	External I/O 3
8	I/O 4	In/out	External I/O 4
9	GND	—	Ground
10	ALM1	Out	Alarm output 1
11	ALM2	Out	Alarm output 2
12	ALM3	Out	Alarm output 3
13	ALM4	Out	Alarm output 4
14	GND	—	Ground
15	N.C. / CAN_H*1	—/Out*1	N.C. / CAN_H communications line*1
16	N.C. / CAN_L*1	—/Out*1	N.C. / CAN_L communications line*1
17	GND	—	Ground

*1. Can be used as CAN terminals on LR8102 only.

Pulse/logic input	Number of terminals	1 Not isolated (the ground shared with the instrument)
	Applicable input type	No-voltage contact, open collector (an external resistor is required when used as PNP open collector), or voltage input
	Maximum input voltage	0 V to 42 V DC
External sampling input	Number of terminals	1 Not isolated (the ground shared with the instrument)
	Input voltage	0 V to 10 V DC High level: 2.5 V to 10 V, low level: 0 V to 0.8 V
External input/output	For input	Input voltage: 0 V to 10 V DC High level 2.0 V to 10 V, low level 0 V to 0.8 V
	For output	Output type: Open drain output (with 5 V voltage output)
		Output voltage: high level: 4.0 V to 5.0 V, low level: 0 V to 0.5 V
		Maximum making/breaking capacity: 5 V to 10 V DC, 200 mA

Alarm output	Number of terminals	4 Not isolated (the ground shared with the instrument)
	Data type	Open-drain output (with 5 V voltage output)
	Output voltage	High level: 4.0 V to 5.0 V, low level: 0 V to 0.5 V Switchable between high level and low level
	Maximum making/breaking capacity	5 V to 30 V DC, 200 mA

Input specifications of the external input terminals (I/O 1, I/O 2, and I/O 3)

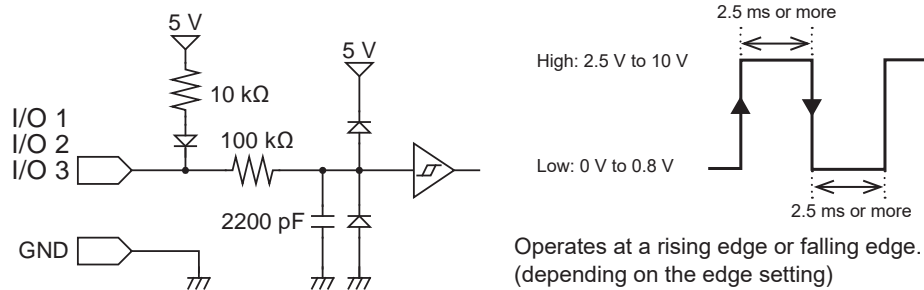

Output specifications of the external output terminal (I/O 4)

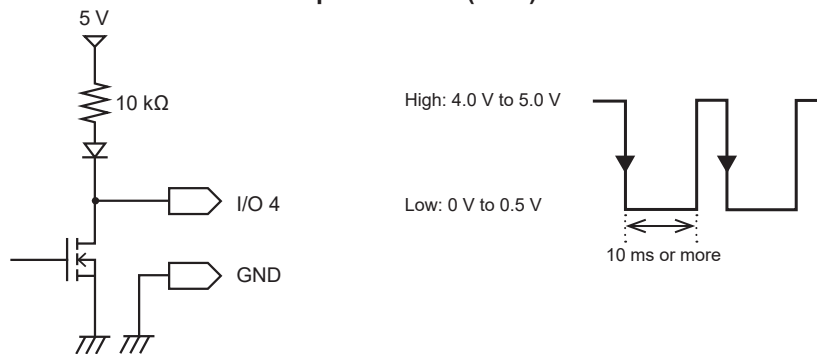

4.2 Specifications of Modules

M7100 Voltage/Temp Module

Operating environment	Indoor use, pollution degree 2, altitude up to 2000 m (6562 ft.)
Operating temperature and humidity range	-10°C to 50°C (14°F to 122°F), 80% RH or less (no condensation)
Storage temperature and humidity range	-20°C to 60°C (-4°F to 140°F), 80% RH or less (no condensation)
Standards	Safety: EN 61010 EMC: EN 61326 Class A
Regular power consumption	2.9 W (during measurement, data refresh interval of 10 ms, all channels set to 10 mV f.s. voltage range and measurement set to on)
Dimensions	Approx. 53W × 166H × 263D mm (2.1W × 6.5H × 10.4D in., excluding protrusions))
Weight	Approx. 1.3 kg (2.9 lb.)
Maximum input voltage	±100 V DC
Maximum inter-channel voltage	300 V DC
Maximum rated line-to-ground voltage	1500 V DC, measurement category II, anticipated transient overvoltage: 8000 V 1000 V AC, measurement category II, anticipated transient overvoltage: 6000 V
Maximum rated inter-module voltage	1500 V DC, 1000 V AC

M7102 Voltage/Temp Module

Operating environment	Indoor use, pollution degree 2, altitude up to 2000 m (6562 ft.)
Operating temperature and humidity range	-10°C to 50°C (14°F to 122°F), 80% RH or less (no condensation)
Storage temperature and humidity range	-20°C to 60°C (-4°F to 140°F), 80% RH or less (no condensation)
Standards	Safety: EN 61010 EMC: EN 61326 Class A
Regular power consumption	2.7 W (during measurement, data refresh interval of 20 ms, all channels set to 10 mV f.s. voltage range and measurement set to on)
Dimensions	Approx. 53W × 166H × 263D mm (2.1W × 6.5H × 10.4D in.)
Weight	Approx. 1.2 kg (2.6 lb.)
Maximum input voltage	±100 V DC
Maximum inter-channel voltage	300 V DC
Maximum rated line-to-ground voltage	600 V AC/DC, measurement category II Anticipated transient overvoltage: 4000 V
Maximum rated inter-module voltage	600 V AC/DC

M7103 Power Measurement Module

Operating environment	Indoor use, pollution degree 2, altitude up to 2000 m (6562 ft.)
Operating temperature and humidity range	0°C to 40°C (32°F to 104°F), 80% RH or less (non-condensing)
Storage temperature and humidity range	-10°C to 50°C (14°F to 122°F), 80% RH or less (non-condensing)
Standards	Safety: EN 61010 EMC: EN 61326 Class A
Applicable standards	Compliant with IEC 61000-4-7:2002+A1:2008 In IEC measurement mode
Dimensions	Approx. 65W × 170H × 255D mm (2.6W × 6.7H × 10.0D in.) (excluding protrusions)
Weight	Approx. 1.5 kg (3.3 lb.)
Maximum input voltage	Voltage input section: 1000 V AC, 2000 V DC Current sensor input section: 8 V, ±12 V peak
Maximum rated line-to-ground voltage	1000 V AC/DC measurement category III, anticipated transient overvoltage 8000 V 1000 V AC/1500 V DC in measurement category II, anticipated transient overvoltage 8000 V

M1100 AC Power Module

Operating environment	Indoor use, pollution degree 2, altitude up to 2000 m (6562 ft.)
Operating temperature and humidity range	0°C to 40°C (32°F to 104°F), 80% RH or less (non-condensing)
Storage temperature and humidity range	-10°C to 50°C (14°F to 122°F), 80% RH or less (non-condensing)
Standards	Safety: EN 61010 EMC: EN 61326 Class A
Power supply	Commercial power supply Rated supply voltage: 100 V to 240 V AC (assuming voltage fluctuations of ±10%) Rated power-supply frequency: 50 Hz/60 Hz Anticipated transient overvoltage: 2500 V
Maximum rated power	400 VA (M1100 at the maximum rated current output) 300 VA (when four M7103 units and six M7100 units are connected)
Normal power consumption	55 W (When two M7103 units are connected, and 20 AAC is measured by connecting CT6872 to all current channels while 1000 V AC is input to all voltage channels)
Dimensions	Approx. 80W × 166H × 238D mm (3.1W × 6.5H × 9.4D in.)
Weight	Approx. 2.0 kg (4.4 lb.)



5

Maintenance and Service

5.1 Repair, Calibration, and Cleaning

Replaceable parts and service life

Some parts used in the instrument deteriorate in characteristics after years of use.

It is recommended to replace these parts regularly to ensure instrument functionality over the long term.

To order replacement, please contact your authorized Hioki distributor or reseller.

Part service life varies with the operating environment and frequency of use.

The recommended replacement interval do not guarantee these parts to operate throughout the period.

Part	Recommended replacement interval	Remarks
Electric double-layer capacitor	About 4 years	Printed circuit boards on which such parts are mounted should be replaced.
Electrolytic capacitor	About 10 years	
Backup battery	About 10 years	If the clock is significantly deviated after the instrument is turned on, the battery should be replaced.
Fan motor	About 10 years	At 23°C

Fuse

The instrument's power supply unit has a built-in fuse. If the instrument cannot be turned on, the fuse may have blown. The fuse cannot be repaired or replaced by the user. Contact your authorized Hioki distributor or reseller.

Calibration

The appropriate schedule for calibration depends on factors such as the operating conditions and environment. Determine the appropriate calibration interval based on your operating conditions and environment and have Hioki calibrate the instrument accordingly.

Transporting the instrument

CAUTION

Observe the following when shipping the instrument:

- **Remove the measurement modules, storage device, accessories, and optional equipment from the instrument.**



- **When requesting repair, include a description of the malfunction.**

- **Use the packaging in which the instrument was initially delivered and then pack that in an additional box.**

Failure to do so could cause damage during shipment.

Cleaning

CAUTION

- **If the instrument becomes dirty, wipe it clean with a soft cloth moistened with water or a neutral detergent.**



Solvents such as benzene, alcohol, acetone, ether, ketone, thinners, or gasoline could deform or discolor the instrument.

- **Periodically clean the vents to avoid blockage.**

When the vents become clogged, the internal cooling effect of the instrument is hampered, which could damage the instrument.

5.2 Troubleshooting

If damage is suspected, read the “Before returning the instrument for repair” (p. 57) section to remedy problems. If this does not help you, contact your authorized Hioki distributor or reseller.

Before returning the instrument for repair

Problem	Cause	Remedy
Even pressing the power key cannot turn the instrument on.	• The power cord is disconnected.	Connect the power cord properly. (p. 24)
	• The AC adapter is not outputting 12 V DC.	The AC adapter cannot be repaired by the user. Contact your authorized Hioki distributor or reseller.
The instrument cannot acquire measured values even after starting a measurement.	• The pre-trigger is set to be used. (The instrument with the pre-trigger set does not accept any triggers until completing to acquire waveforms for the pre-trigger.)	Turn the pre-trigger setting off if you do not want to use the pre-triggers function. See “5.2 Enabling the Trigger Function” in the Instruction Manual.
	• The trigger is set to be used.	Turn the trigger setting off if you do not want to use the triggers function. See “5.2 Enabling the Trigger Function” in the Instruction Manual.
Measured values do not change.	• Cables are disconnected or have a break.	Connect the cables properly. See “2.5 Connecting Cables” in the Instruction Manual.
	• The range setting is not appropriate.	Select an appropriate range. See “3.4 Setting the Voltage/Temp Module” in the Instruction Manual.
The instrument cannot save data to storage devices (SD memory card or USB flash drive).	• A storage device other than Hioki optional equipment is used.	Make sure to use Hioki optional SD Memory Card or USB Drive. Storage devices other than Hioki’s optional equipment are not guaranteed to operate regularly.
	• The storage device is not inserted securely.	Insert the storage device securely. See “2.7 SD Memory Card and USB Drive” in the Instruction Manual.
	• The storage device is not formatted.	Format the storage device before the first use. See “6.2 Formatting Media” in the Instruction Manual.
	• The storage device does not have enough space available.	Format it or use another device.
	• A folder contains 1000 files or more.	Decrease the number of files in the folder to 1000 or less. Although a folder can contain 1000 files or more, it will take a long time to save a lot of files.

If the cause of your problem remains unclear

Execute a system reset.

See “3.3 Resetting the Instrument” (p. 45).

When the instrument cannot be turned off

Hold down the power key for 5 s. This will turn the instrument off forcibly.

5.3 Error messages

Error messages

Error messages include *errors* and *warnings*.

When an error or warning has occurred in the instrument, you can check those states using the communications commands.

Refer to the following tables for the error details and remedies.

Note that the measurement stops if an error occurs.

Error messages

No.	Bit No.	Description	Remedy
ERR_SY01	0	The program has been corrupted. The instrument needs require.	Turn the instrument off and request repair.
ERR_SY03	2	The clock correction circuit error is detected. The instrument needs require.	Turn the instrument off and request repair.
ERR_SY04	3	The instrument abnormally heats internally.	Check to see if the operating temperature is high or if the fan stops. If this message is displayed even the temperature is within the operating temperature range, request repair.
ERR_SY05	4	A hardware error is detected.	Turn the instrument off and request repair.
ERR_SY06	5	Module error of module No. 1	The module cannot be recognized normally. The module may be malfunctioning. Request repair.
ERR_SY07	6	Module error of module No. 2	
ERR_SY08	7	Module error of module No. 3	
ERR_SY09	8	Module error of module No. 4	
ERR_SY10	9	Module error of module No. 5	
ERR_SY11	10	Module error of module No. 6	
ERR_SY12	11	Module error of module No. 7	
ERR_SY13	12	Module error of module No. 8	
ERR_SY14	13	Module error of module No. 9	
ERR_SY15	14	Module error of module No. 10	
ERR_SY16	15	CAN controller error	Turn the instrument off and request repair.
ERR_SY17	16	The instrument's fan malfunctions.	
ERR_PW01	32	The M7103 Power Measurement Module's fan malfunctions.	
ERR_PW02	33	The M1100 AC Power Module's fan malfunctions.	

No.	Bit No.	Description	Remedy
ERR_PW04	35	Module error Module No. 1	M7103 Power Measurement Module cannot be recognized properly. The module may be malfunctioning and should be serviced.
ERR_PW05	36	Module error Module No. 2	
ERR_PW06	37	Module error Module No. 3	
ERR_PW07	38	Module error Module No. 4	

Warning messages

No.	Bit No.	Description	Remedy
WARN_SY01	0	Failed to upgrade.	Turn the instrument off and upgrade it again. If the upgrade fails again, request repair.
WARN_SY02	1	The instrument heats internally. Check to see if the operating environment is inappropriate.	Check to see if the instrument has been installed improperly. See "Installing the instrument" (p. 10).
WARN_SY03	2	The instrument heats internally. Check to see if the operating environment is inappropriate.	Check to see if the instrument has been installed improperly. See "Installing the instrument" (p. 10).
WARN_SY04	3	No channel is selected for measurement.	Measurement settings of all channels are set to off. Set the measurement settings of at least one channel to on to start a measurement. Sending a command to start a measurement causes the <i>WARN_COM02</i> communications command error if the measurement settings of all channels are set to off.
WARN_SY05	4	Resetting the instrument has failed.	Execute the instrument reset. Key operation during the instrument reset may result in this error. Do not operate any keys during the instrument reset
WARN_SY06	5	System warning (SY06) occurs. Turn the instrument off, then on.	Turn the instrument off, then on.
WARN_SY07	6	Cables are connected inappropriately. Check to see if the primary and secondary instruments have been connected and set improperly.	Check to see if the primary and secondary instruments have been connected and set improperly. See "Wiring the optical connection cable (LR8102 only)"
WARN_SY08	7	An interruption the synchronization signal stopped the measurement.	Turn the instrument off, then on.
WARN_SY09	8	Module connection error The instrument with the present module configuration cannot be used. Review the connections.	Check to see if the measurement modules are connected improperly. Warnings occur in the following cases: <ul style="list-style-type: none"> • More than 11 modules are connected. • More than five M7103 modules are connected. • Another module is connected between M7103 and this instrument. • M7103 is connected but M1100 is not connected.
WARN_FL01	24	File processing error	Unexpected abnormality occurred while the instrument was processing files on the SD Memory card or USB Drive. Replace the storage device with another. Alternately, turn the instrument off, then on.
WARN_FL02	25	Waveform data is not found.	Acquire waveform data.

No.	Bit No.	Description	Remedy
WARN_FL03	26	Numerical calculation data is not found.	Execute numerical calculations.
WARN_FL04	27	The instrument cannot load this file.	The selected file is in the format that the instrument cannot load, or the selected file is corrupt. Load a suitable file.
WARN_FL05	28	Insufficient storage memory	The file cannot be saved because the storage device does not have enough space available. Delete unnecessary files to secure sufficient space or use a new storage device.
WARN_FL06	29	The storage device does not have enough space available, or the instrument failed to delete older files to save another file.	The file could not be saved because the SD Memory Card or USB Drive does not have enough space available. Delete unnecessary files to secure sufficient space or use a new storage device.
WARN_FL07	30	This folder cannot be deleted or renamed on the instrument.	This message is displayed to prevent data folders from being mistakenly deleted. Use a PC to delete or change the folder name.
WARN_FL08	31	The file is damaged.	The file cannot be loaded because the information in the file is damaged. Load a suitable file.
WARN_FL10	33	This folder/file is protected.	The read-only folders and files cannot be deleted. Use a PC to delete these folders or files.
WARN_FL11	34	Data cannot be loaded because the model configuration of the plug-in modules does not match that in the file.	Data can be loaded in overwrite mode only when the configuration of the plug-in modules is the same as when the data was saved. Check the module configuration using browsing mode.
WARN_FL12	35	A storage device is not found.	Insert an SD Memory Card or USB Drive.
WARN_FL13	36	Insert an SD Memory Card or USB Drive.	Insert an SD Memory Card or USB Drive.
WARN_FL14	37	The storage device does not have enough space available.	Free space on the device is insufficient. Replace the device with another.
WARN_FL15	38	Insert a storage device. Unsaved data will be deleted soon.	If the real-time saving operation is started without inserting any storage device, this warning is displayed when the data on the internal buffer memory exceeds 50% of the memory capacity. Insert an SD Memory Card or USB Drive.
WARN_FL16	39	Some data is not saved yet.	No SD Memory Card or USB Drive is inserted or the storage device does not have enough space available. Insert an SD memory card or USB drive to save the necessary data manually.

Error messages

No.	Bit No.	Description	Remedy
WARN_FL17	40	A long file name, including the folder path, caused a file-operation failure.	The specified path name is too long. Use a PC to shorten the name of the folder saved on the SD Memory Card or USB Drive.
WARN_FL18	41	The instrument is busy with another task.	Wait for the instrument to complete the task to operate it.
WARN_SU04	59	The instrument with the present settings cannot start a measurement. Optimize the following settings: For details, see the Instruction Manual. <ul style="list-style-type: none"> Recording interval Number of channels with the measurement set to on Auto-saving format 	The available channels are limited depending on the recording interval and auto-saving settings. <ul style="list-style-type: none"> Recording interval Number of channels with the measurement set to on See the "Number of channels that can be output during each recording interval" section of "12.8 Outputting the Measured Value Using LAN2" in the Instruction Manual. <ul style="list-style-type: none"> Auto-saving format See the "Auto save (Realtime save)" section of "6.3 Saving Data" in the Instruction Manual.
WARN_COM02	65	Communications command error	Check the communications command description.
WARN_COM03	66	No communications command was input.	Check the communications command contents.
WARN_FTP01	72	The instrument failed to connect to the FTP server.	Check the FTP data auto-sending setting and the connection.
WARN_FTP02	73	A target file for an FTP data auto-transfer was not found.	Use FTP to manually acquire the file that has not been sent from the instrument or load the file from the storage device set as a recording destination.
WARN_PW01	76	The connected sensor is different from the setting.	If the measurement lines are identically wired, connect a current sensor of the same rating. Or, there is a current sensor reading error. Check the connection. Check the connection.
WARN_PW04	79	The current sensor has been changed.	—
WARN_PW05	80	The voltage of the sensor power supply is low.	Turn off the instrument and check the operating environment.
WARN_PW06	81	The voltage of the sensor power supply has been low for more than 1 second.	

5.4 Disposing of the Instrument

The instrument contains a lithium battery to back up data. Remove the lithium battery to dispose of it according to local regulations before disposing of the instrument.

DANGER

- Do not short-circuit the battery.
- Do not charge the battery.
-  ■ Do not disassemble the battery.
- Do not throw the battery into a fire or heat it up.

Doing so will cause the battery to explode, resulting in bodily injury.

WARNING



- Turn the instrument off and remove the power cord and cables before removing the lithium battery.

Failure to do so could cause the user to experience an electric shock.



- Store the removed battery out of reach of children.

Failure to do so could cause children to swallow the battery accidentally.

Dispose of the battery by local regulations.

CALIFORNIA, USA ONLY

Perchlorate Material - special handling may apply.

See <https://dtsc.ca.gov/perchlorate/>

How to remove the lithium battery

You will need: Phillips screwdriver (No. 2), tweezers

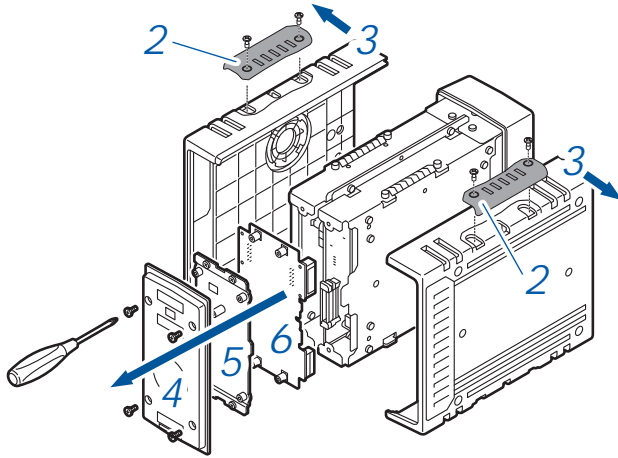

- 1 Confirm that the instrument has been turned off and remove the power cord and the cables.
- 2 Remove the four covers.
- 3 Remove the both side panels.
- 4 Remove the rear panel.
- 5 Remove the plate at the rear.
- 6 Remove the motherboard.

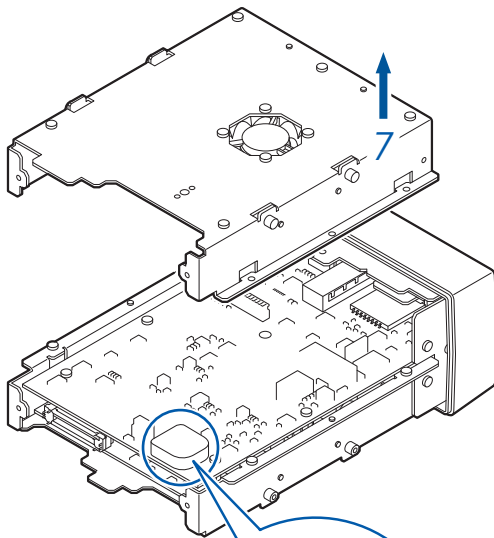

- 7 Remove the plate.

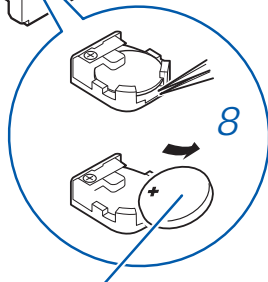

- 8 Insert the tip of the tweezers between the battery and the battery holder and lift up on the battery to remove it.

Lithium battery

Warranty Certificate

HIOKI

Model	Serial number	Warranty period Three (3) years from date of purchase (___ / ___)
-------	---------------	--

Customer name: _____

Customer address: _____

Important

- Please retain this warranty certificate. Duplicates cannot be reissued.
- Complete the certificate with the model number, serial number, and date of purchase, along with your name and address. The personal information you provide on this form will only be used to provide repair service and information about Hioki products and services.

This document certifies that the product has been inspected and verified to conform to Hioki's standards.

Please contact the place of purchase in the event of a malfunction and provide this document, in which case Hioki will repair or replace the product subject to the warranty terms described below.

Warranty terms

1. The product is guaranteed to operate properly during the warranty period (three [3] years from the date of purchase).
If the date of purchase is unknown, the warranty period is defined as three (3) years from the date (month and year) of manufacture (as indicated by the first four digits of the serial number in YYMM format).
2. If the product came with an AC adapter, the adapter is warranted for one (1) year from the date of purchase.
3. The accuracy of measured values and other data generated by the product is guaranteed as described in the product specifications.
4. In the event that the product or AC adapter malfunctions during its respective warranty period due to a defect of workmanship or materials, Hioki will repair or replace the product or AC adapter free of charge.
5. The following malfunctions and issues are not covered by the warranty and as such are not subject to free repair or replacement:
 - 1. Malfunctions or damage of consumables, parts with a defined service life, etc.
 - 2. Malfunctions or damage of connectors, cables, etc.
 - 3. Malfunctions or damage caused by shipment, dropping, relocation, etc., after purchase of the product
 - 4. Malfunctions or damage caused by inappropriate handling that violates information found in the instruction manual or on precautionary labeling on the product itself
 - 5. Malfunctions or damage caused by a failure to perform maintenance or inspections as required by law or recommended in the instruction manual
 - 6. Malfunctions or damage caused by fire, storms or flooding, earthquakes, lightning, power anomalies (involving voltage, frequency, etc.), war or unrest, contamination with radiation, or other acts of God
 - 7. Damage that is limited to the product's appearance (cosmetic blemishes, deformation of enclosure shape, fading of color, etc.)
 - 8. Other malfunctions or damage for which Hioki is not responsible
6. The warranty will be considered invalidated in the following circumstances, in which case Hioki will be unable to perform service such as repair or calibration:
 - 1. If the product has been repaired or modified by a company, entity, or individual other than Hioki
 - 2. If the product has been embedded in another piece of equipment for use in a special application (aerospace, nuclear power, medical use, vehicle control, etc.) without Hioki's having received prior notice
7. If you experience a loss caused by use of the product and Hioki determines that it is responsible for the underlying issue, Hioki will provide compensation in an amount not to exceed the purchase price, with the following exceptions:
 - 1. Secondary damage arising from damage to a measured device or component that was caused by use of the product
 - 2. Damage arising from measurement results provided by the product
 - 3. Damage to a device other than the product that was sustained when connecting the device to the product (including via network connections)
8. Hioki reserves the right to decline to perform repair, calibration, or other service for products for which a certain amount of time has passed since their manufacture, products whose parts have been discontinued, and products that cannot be repaired due to unforeseen circumstances.

HIOKI E E CORPORATION

18-07 EN-3

HIOKI

HIOKI E.E. CORPORATION

2402 EN

Edited and published by HIOKI E.E. CORPORATION

Printed in Japan

- Contents subject to change without notice.
- This document contains copyrighted content.
- It is prohibited to copy, reproduce, or modify the content of this document without permission.
- Company names, product names, etc. mentioned in this document are trademarks or registered trademarks of their respective companies.