

GETTING STARTED

7-day chart rotation
0 to 100°F

QUICK START

1. Remove the protective pen cap(s).
2. Connect Probe(s):
 - a. KT8P0/2/3: Make sure the KTC probe is connected firmly to the Replaceable Sensor and that the Replaceable Sensor is plugged in firmly to the chart recorder.
 - b. KT856: Make sure both KTC probes are plugged in firmly to the chart recorder.
3. Insert batteries and plug in AC adapter (See Figure 3). KT8P0:4 AA batteries required; KT8P2/3 & KT856: 4 AA batteries backup power only (See page 5 for backup life). Unit will power on.
4. The instrument will move pen(s) to the appropriate readings.
5. Install the chart that matches the Dip Switch settings (See p.4).

Press the **PEN HOME** key to move the pen(s) to the outside of the chart. The pen(s) is automatically raised off the chart.

Remove the old chart, place the new chart on the Chart Hub being certain that the edge of the chart slides under the Chart Guide Clips located at the outside of the chart.

6. Set the appropriate time. There are two ways to adjust the chart and set the appropriate time:
 - a. Set the chart time manually by inserting a coin into the groove in the chart hub and turning clockwise until the correct hour (and day if applicable) on the chart is referenced to the timing arrow (just to the right of the pen tip on the dial). Press **Pen Home** to move the pen(s) back onto the chart.

The following feature should be used for fine adjustments only.

- b. To adjust the chart time, press and hold **Adjust-Up** and **Adjust-Down** buttons located on the back of the unit next to the dip switch (see Figure 3).

The green LED will blink rapidly for about five seconds, then the LED will remain solid green. While in this state the **Adjust-Up** button will move the chart backward (counter clockwise) and the **Adjust-Down** button will move the chart forward (clockwise).

Rotate the chart until the correct hour (and day if applicable) on the chart is referenced to the timing arrow. Once you have set your chart, press the **Pen Home** button to exit Chart Adjust Mode. The unit will take one minute to exit the Chart Adjust Mode once **Pen Home** is pressed. Press **Pen Home** to move the pen(s) back onto the chart.

- c. Place the KT8 recorder on a flat vibration-free surface. Be sure it is in a vertical position and level. For best performance and longevity, the location should be a clean environment, free from dust and corrosive fumes. Do not exceed temperature specifications. **Wall Mount:** Keyhole slots are provided on the KT8 recorder for wall mounting.

DISPLAY SYMBOLS KT8P

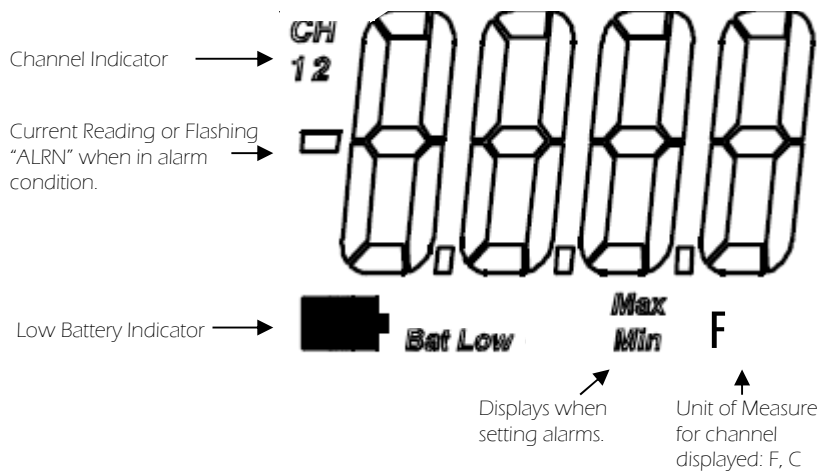

BUTTON OPERATION

Figure 2

KT8P3/KT855

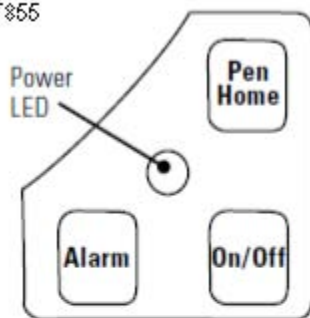

KT8P0/2

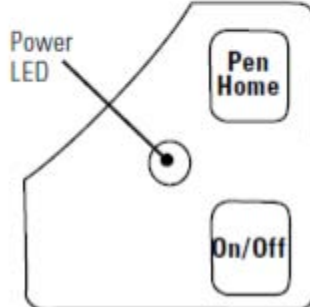
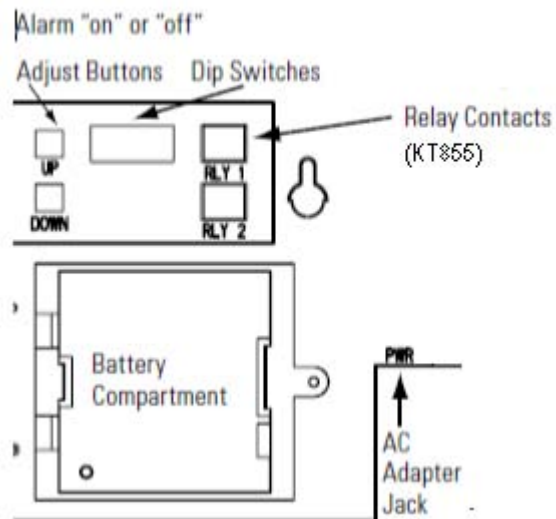

Figure 3



On/Off

The On/Off key turns the unit on and off.

Pen Home (Down Arrow)

If the pen(s) are located on the outside edge of the chart, press the **Pen Home** to move pen(s) to recording position. If the pen(s) are located on the chart, press the **Pen Home** key to move the pen(s) to the outside edge of the chart.

Alarm (Optional)

Pen 1: = Red Pen
Pen 2: = Blue Pen

1. To set the alarm, make sure unit is on and press and hold the **Alarm** button. The LED will blink red rapidly for about five seconds, then the LED will turn solid green. Release the **Alarm** button and the LED will turn solid red. At this point the display will show "On" or "Off".

Pressing either the **Adjust-Up** or **Adjust-Down** buttons, located on the back of the unit next to the dip switch, will toggle the alarm on or off.

2. Pressing **PEN HOME** will scroll to the next alarm options.

Pen 1 alarm minimum

Pen 1 alarm maximum

If KT856 two pen model, the additional options are:

Pen 2 alarm minimum

Pen 2 alarm maximum

3. In order to set pen(s) alarm minimums and maximums, pressing **Adjust-Up** will increase the alarm value, and pressing **Adjust-Down** will decrease the alarm value. There is acceleration if the **Adjust-Up** button is held down.

Repetitively pressing the **Pen Home** button will scroll through the five options until the **Alarm** button is pressed to exit from alarm adjust. Each press of the **Pen Home** or **Alarm** button will store the new settings. The unit will take one minute to exit Alarm Set Mode once the **Alarm** button is pressed.

4. If the alarm is triggered, the LED will show as solid red and the alarm will sound. Press the **Alarm** button to silence the audible alarm.

Alarm Relays

The SPST 24V 500mA relay contacts are Normally open and will close on alarm conditions when the alarms are enabled. Relay contacts are always functional when the alarm is enabled. The relay will close only during minimum and maximum alarm conditions. The KT856 has 2 sets of relay contacts which operate independently. Relays will not operate under battery only power conditions.

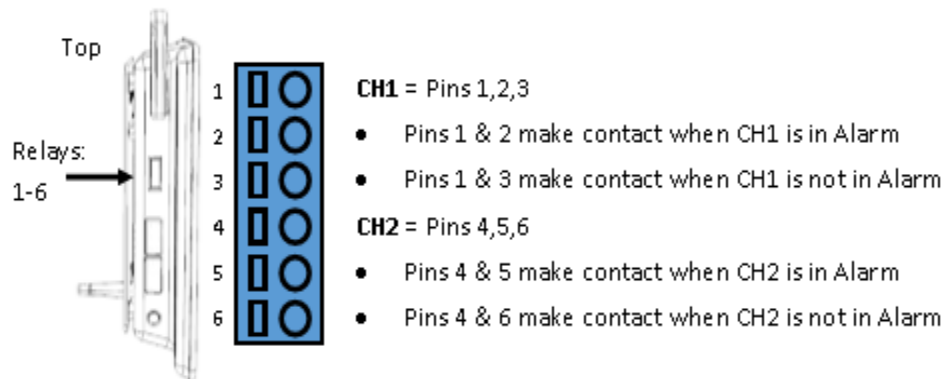

PENS

The blue pen has a longer pen arm and records channel 2 temperature (depending on your dip switch selection, see pg. 4). The red pen has a shorter arm and records channel 1 temperature. The pens are offset to allow the red pen to glide under the blue pen. The blue pen indicates the correct time and the red pen precedes it by 3/16 of an inch.

DIP SWITCH SETUP

To setup the KT8 recorder for your specific application, you might need to change some of the Dip Switches. The Dip Switches are located on the back of the unit. (Figure 3)

Use a pen or small screw driver to flip the switches. Remember to install the correct chart to match the corresponding Dip Switch setting.

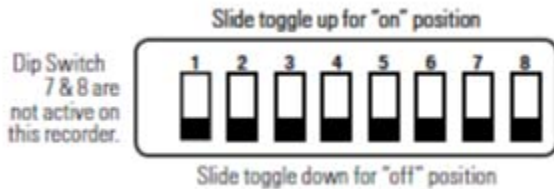

Dip Switches for Ranges:

| KT8 Dip Switch Setting | | Up=On | Down=Off | | | | |
|------------------------|----------------|-------|----------|---|---|---|---|
| Switches 1-6 | For Model | 1 | 2 | 3 | 4 | 5 | 6 |
| 7-Day | | D | D | | | | |
| 24-Hour | | D | U | | | | |
| 31-Day | Not For KT800 | U | U | | | | |
| Fahrenheit | | | | D | | | |
| Celsius | | | | U | | | |
| -80 to 50° F/C | | | | | D | D | U |
| -20 to 20° F/C | | | | | U | U | U |
| 0 to 100° F/C | | | | | D | D | D |
| 0 to 150° F/C | | | | | D | U | D |
| 0 to 250° F/C | | | | | D | U | U |
| 0 to 500° F/C | | | | | | U | D |
| 0 to 1000° F/C | A203 High Temp | | | | | U | D |
| 0 to 2000° F | Probe Required | | | | | U | U |

Remember to install the correct chart to match corresponding switch setting.

DICKSON • Addison, IL • www.DicksonData.com

Reording Time

All the KT8 recorders feature usre selectable recording times.

| | |
|------------------------|---------|
| 24-hour all models | #1 down |
| | #2 up |
| 7-day all models | #1 down |
| | #2 down |
| 31-day KT8P2/3 & KT856 | #1 up |
| | #2 up |

°F/C

You can record in °F or °C with the KT8 by using dip switch #3.

| | |
|----|---------|
| °F | #3 down |
| °C | #3 up |

Note: Remember to install the correct chart to match corresponding switch setting.

Temperature Ranges

| | |
|------------------|---------|
| 0 to +100° F/C | #4 down |
| | #5 down |
| | #6 down |
| -50 to +50° F/C | #4 down |
| | #5 down |
| | #6 up |
| 0 to +250° F/C | #4 down |
| | #5 up |
| | #6 up |
| 0 to +500° F/C | #4 up |
| | #5 down |
| | #6 down |
| 0 to +150° F/C | #4 down |
| | #5 up |
| | #6 down |
| -20 to +20° F/C | #4 up |
| | #5 up |
| | #6 up |
| 0 to +1000° F/C* | #4 up |
| | #5 down |
| | #6 up |
| 0 to +2000° F/C* | #4 up |
| | #5 up |
| | #6 down |

* A203 High Temp Probe required - Range not available on Model KT800

POWER

The KT8 operates on AC power with an optional 4 AA battery backup. Depending on chart rotation selected and model; battery backup will last

KT8P2/3 & KT856

24 Hour Chart Rotation = 1 Day Backup

7 Day Chart Rotation = 2 Day Backup

31 Day Chart Rotation = 1 Week Backup

Note: Alarm and relays will not operate under battery only power.

KT8P0

At 70°F

24 Hour Chart Rotation = 1 Month

7 Day Chart Rotation = 6 Months

At 32°F

24 Hour Chart Rotation = 3 Weeks

7 Day Chart Rotation = 4 Months

Note: (Unit should not be placed in an environment below 32°F)

LED Indicators

- AC Power with Battery Backup - Solid Green
- AC Power with Low Battery or No Battery - Blinks Red
- Battery Only - Blinks Green
- Battery Only (Low Battery) - Solid Red

Note: KT8P0 operates on battery only and will blink one time every minute to conserve battery life.

PEN HOME ADJUST

If over time the pen location does not match the display, you may need to adjust the pen location on the chart. A Pen Home Adjustment will not affect calibration of the sensor, but rather corrects for the natural drift that occurs with mechanical moving parts over time.

1. While the unit is on, press and hold both **Pen Home** and **On/Off** buttons until the LED is solid green. Release the **Pen Home** and **On/Off** buttons. The LED will flash amber and green for one second then the LED will turn off.
Note: Press **Pen Home** first so the unit will not turn off
2. The pen(s) will move to the outer edge of the chart, and then the shorter **red** pen will move to the outer chart ring (maximum temperature/RH line).
3. If the red pen tip does not line up with the outer chart ring, use the **Adjust-Up** and **Adjust-Down** buttons (on the back of the unit) to move the red pen so that the pen tip is on top of the outer chart ring.
4. Once set press **On/Off** to save and exit Pen Home Adjust. If using KT856 continue to step 5 below.
5. Once the shorter red pen is set, press **Pen Home** to move the shorter red pen to the outer edge of the chart. The longer blue pen will move to the out chart ring.
6. If the blue pen tip does not line up with the out chart ring, use the **Adjust-Up** and **Adjust-Down** buttons to move the blue pen so that the pen tip is on top of the outer ring.
7. Once the blue pen is set, pressing the **Pen Home** button will move the longer blue pen to the outer edge of the chart and the shorter red pen will move to the outer chart ring.

- Each time **Pen Home** is pressed the two pens will switch positions (moving the most recently adjusted position) until **On/Off** is pressed to exit pen adjust mode.

Note: Pressing the On/Off button will exit the adjustment and return the unit to normal operation. Each time the Pen Home or On/Off button is pressed, the adjustment currently in progress will be stored. The unit will take one minute to exit Pen Adjust Mode once the On/Off button is pressed.

CALIBRATION

KT8P0/2/3:

The R400 Replaceable Sensor was carefully tested and calibrated before being shipped from the factory. For greatest accuracy, we recommend replacing the sensor every 6-12 months (does not include N400 and N450).

When your new Replaceable Sensor arrives, simply turn off the recorder, remove and discard the old sensor, plug in the new one and power the recorder back on. Your recorder will continue to record temperature and humidity without interruption.

KT856:

The KT856 was carefully tested and calibrated before being shipped from the factory. For greatest accuracy, we recommend factory re-calibration every 6-12 months. Call customer service at (630) 543.3747.

USER CALIBRATION

If you have an accurate standard to compare against, the Replaceable Sensor or unit (KT856) calibration can be adjusted at one point. This will not adjust the span and is not as accurate as replacing the Replaceable Sensor with a newly calibrated one, or returning the KT856 for recalibration.

- To activate Calibration mode, turn the unit on and press and hold both the **On/Off** and the **Adjust-Down** button until the LED is solid green. The LED will then blink amber at which point only the pen being adjusted will show on the display.
Note: Make sure to press the Adjust-Down button first so the unit will not turn off
- To raise the unit of measurement, press the **Adjust-Down** button. To lower the unit of measurement, press the **Adjust-Up** button. Pressing **Pen home** switches between the red and blue pens on a two pen unit and stores the current adjustment value.
- When Calibration is complete, press the **On/Off** button. The adjustment is stored in memory even after you turn the unit off or if AC power fails.

Note: After two hours, if no buttons are pressed, the unit will time out of Calibration mode and resume normal operation. If you wish to cancel the Calibration, simply enter Calibration mode and toggle through the steps without adjusting displayed readings. Exit by pressing the **On/Off** button. You have now restored factory calibration settings.

Note: It is recommended that you use a controlled chamber when determining if Calibration is necessary. Adjusting the pen locations in an open room is not recommended as humidity can vary greatly within a very small area.

NEED TO KNOW

The pen movement for the KT8P0 is slower than on the AC powered models in order to conserve battery power. In 24-hour mode the pen(s) will move every 1 minute and 30 seconds. In 7-day mode the pen(s) will move every 8 minutes and 30 seconds.

The recorder takes temperature readings every 50 seconds. An average of the reading taken between pen(s) movements is what is drawn on the chart.

TROUBLE SHOOTING

Why isn't the chart keeping time or running slow?

- The chart may be hung up or restricted, possibly caused by a rip on the outer edge of the chart or the chart hub, or the chart may be caught between the arm and pen(s) arm platform.
- Incorrect chart installed for the selected chart speed.

Why did the chart stop turning?

- Chart hung up or restricted, (ripped chart)
- Unit may be "locked up", this can be confirmed by pressing any of the buttons on the keypad, if the unit is locked up there will be no response to button presses and the Chart Recorder may appear to be working, but the readings won't change, also the chart will not rotate. Remove power and battery, and then re-power.

Why don't the display and chart match?

- Dip switches set for a specific range, but using chart for another range, or vice versa.
- Pen(s) not inserted on pen arm(s) all the way
- To adjust pen(s) to match chart see "Pen Home Adjust" in the "Need to Know" section of this manual.

Why does the display read PROB?

- Check the sensor pod and KTC probe(s). Make sure it is properly plugged into the unit.
- Is the unit locked up? This can be confirmed by pressing any of the buttons on the keypad, if the unit is locked up there will be no response to button presses and the unit may appear to be working, but the readings won't change, also the chart will not rotate. Remove power and battery, and then re-power.

Why does calibration seem to be off?

- What is the tolerance of the unit it's being compared to?
- It's ok if the unit is within the sum of the two tolerances.
- Has an outside calibration house attempted calibration? It may not have been adjusted properly.
- Walk through calibration adjustment, found in the manual

Why won't the battery back-up work?

- Are there good batteries in the Chart Recorder?
- Keep in mind that battery backup varies significantly depending on temperature, pen movement and chart rotation speed.
- If there was a momentary power outage (Brown out), the unit may not have had enough time to recognize this and switch to battery mode. (The Chart Recorder may lock up or shut off in this situation) This situation may also occur if the unit is plugged into an outlet that shares the circuit with other machinery that has phase motors or compressors that cycle periodically. As these other machines cycle, they momentarily have a high current draw, therefore drawing from the unit.

Why won't the chart recorder respond to changes?

- Is the unit locked up? This can be confirmed by pressing any of the buttons on the keypad, if the unit is locked up there will be no response to button presses and the unit may appear to be working, but the readings won't change, also the chart will not rotate. Remove power and battery, and then re-power.

Why won't the unit power up?

- Remove the batteries and power adapter for a minute or two, this will reset the unit. The unit should respond when the adapter is plugged in.

WARRANTY

Dickson warrants that this line of instruments will be free from defects in material and workmanship under normal use and service for a period of twelve months after delivery.

This warranty does not cover routine calibration and battery replacement.

Replaceable Sensor Certificate of Validation

Dickson ensures that the Replaceable Sensors / Instruments listed below were developed, tested and validated together.

Replaceable Sensor Model: R400

Instrument Model: KT8P0, KT8P2, KT8P3

Operation: The Instruments and Replaceable Sensor models listed above were specifically designed to work together. No other sensors will work with the Instrument models listed. No other Instrument will work with the Replaceable Sensors listed. The Replaceable Sensor must be connected to the Instrument for the Instrument to operate properly.

Calibration: Only the Replaceable Sensor is calibrated. The sensor, and all calibration defaults and adjustments are stored on the Replaceable Sensor. Accuracy is strictly controlled by the sensor – no adjustments are made by the Instrument. Readings are sent from the Replaceable Sensor to the Instrument for storage purposes only. Certificates of Calibration / NISTs are only supplied for the Replaceable Sensor for this reason.

Recalibration: When a Replaceable Sensor is due for recalibration the existing Replaceable Sensor can be replaced with a new Replaceable Sensor thus eliminating the need to return the entire instrument for recalibration. Replaceable Sensors can be returned for recalibration as well.