

# Current Switch: Auto Calibration, Narrow Limit Process Control

## H10F



H10F



### SPECIFICATIONS

<b>Sensor Power</b>	Induced from monitored conductor
<b>Isolation</b>	600VAC RMS (UL); 300VAC RMS (CE)
<b>Temperature Range</b>	-15° to 60° C (5° to 140°F)
<b>Humidity Range</b>	10-90% RH non-condensing
<b>Frequency Range</b>	50/60 Hz
<b>Trip Point Calibration Learn Period</b>	30 sec. learn period
<b>Normal-to-Alarm Status Output Delay</b>	1 second max.
<b>Alarm-to-Normal Status Output Delay</b>	30 seconds nominal*
<b>Status Output</b>	±20% of learned current to trigger alarm; ±15% of learned current to release alarm (see graph)
<b>Terminal Block Wire Size</b>	24-14 AWG (0.2 to 2.1 mm <sup>2</sup> )
<b>Terminal Block Torque</b>	3.5 to 4.4 in-lbs (0.4 to 0.5 N-m)
<b>Agency Approvals</b>	UL 508 open device listing; CE: EN61010-1, CAT III, pollution degree 2, basic insulation

\*If current switch experiences a momentary loss of power, 30 second delay may or may not apply.

Do not use the LED status indicators as evidence of applied voltage.



### PRODUCT FUNCTIONS

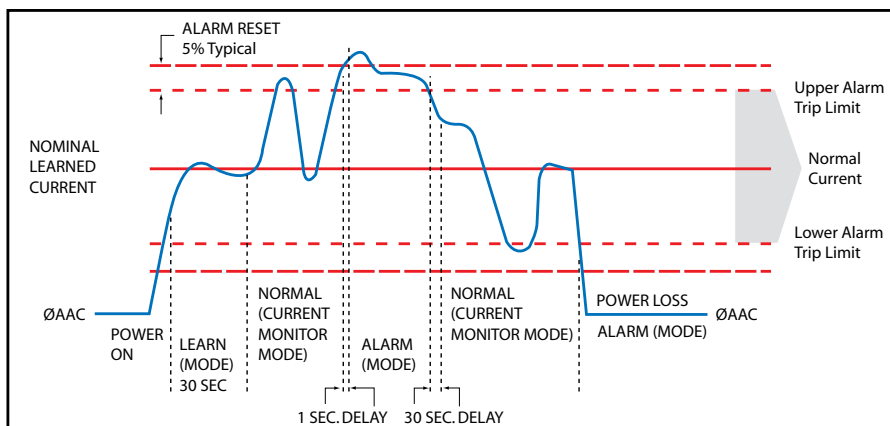

### Automatically Learns At Initial Power-Up

#### FEATURES

- Automatic adjustable trip point (3.5-100A)...precise control of current trip point
- 100% solid state...no moving parts to fail
- Removable mounting bracket for installation flexibility
- 5-year warranty
- Automatic calibration...reduced errors and installation costs
- Microcontroller based learning technology...automatically learns load upon initial power-up...eliminates labor associated with calibration
- Monitors current for both under- and over-load in one package
- Small size fits easily inside small starter enclosures...saves space

#### DESCRIPTION

The **Hawkeye TruStat H10F** is a microprocessor based, self-learning, self-calibrating current switch. It provides calibration-free status, for both under-current and over-current conditions. At initial power-up, the H10F automatically learns the average current on the line with no action required by the installer. Once a current is learned, the switch monitors for changes in current greater than ±20% of the learned load.

#### APPLICATIONS

- Verifying lighting circuit and other electrical service run times
- Monitoring status of industrial process equipment
- Monitoring status of critical motors (compressor, fuel, etc.)

**WIRING DIAGRAM**

Monitoring Fan /Pump Motors for Positive Proof of Flow

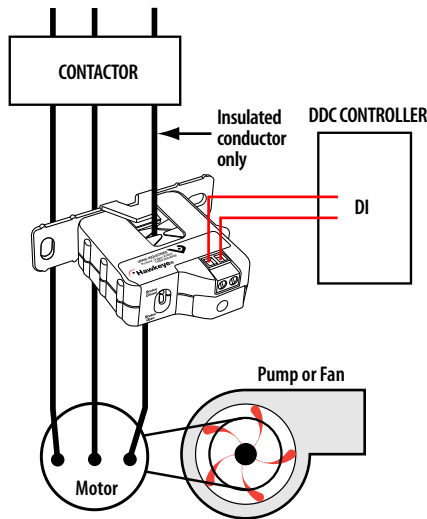

\* Terminal block may extend up to 1/8" over the height dimensions shown.

**DIMENSIONAL DRAWING**

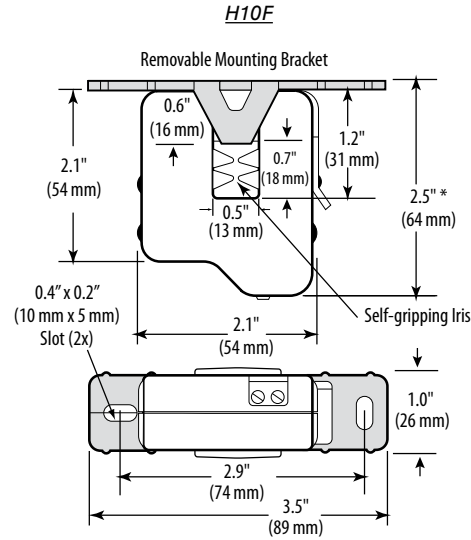

**HOW IT WORKS**

The compact split-core H10F current switch monitors a learned load current to detect power loss and electrical overload. The push-button initiated LEARN MODE allows resetting of the monitored current when the load changes due to system alterations.

**LEARN MODE**

- Unit automatically enters LEARN MODE upon initial power-up
- Auto-calibration is achieved by averaging the load current for 30 seconds
- During this stage, green and red LEDs alternately blink on/off
- STATUS OUTPUT contacts are closed
- LEARN MODE may be initiated manually

**NORMAL MODE**

- Initiated after the 30-second learning period, or immediately upon power-up if sensor has already learned a load
- The red LED is off, and the green LED is blinking
- STATUS OUTPUT contacts are closed

**ALARM MODE**

- The ALARM state signals low current, high current, or power loss conditions
- Initiated within 1 second when any load current excursion exceeds a nominal  $\pm 20\%$
- ALARM will persist until the load current returns to within a nominal  $\pm 15\%$  of the learned current value, or when power is restored to normal
- The 5% ALARM-to-NORMAL MODE reentry margin prevents alarm signal oscillations. This feature is enhanced by a 30 second delay, to insure true nominal load current conditions when returning to NORMAL MODE from an ALARM state
- The green LED is off, and the red LED blinks
- STATUS OUTPUT contacts are open

OPERATING MODES	STATUS LEDs		STATUS OUTPUT
	GREEN	RED	
LEARN (30 secs)	Alternating Blink On/Off		Contacts Closed
NORMAL	Blink	Off	Contacts Closed
ALARM*	Off	Blink	Contacts Open

\* 1 sec maximum after detection.

**ORDERING INFORMATION**



MODEL	AMPERAGE RANGE	STATUS OUTPUT	NOMINAL TRIP POINT TARGET RANGE*	NOMINAL ALARM RESET RANGE*	HOUSING	STATUS LED	UL	CE	RoHS
H10F	3.5 - 100A	N.O.1.0A@30VAC/DC	$\pm 20\%$	$\pm 15\%$	Split-core	●	● <sup>1</sup>	●	●

\*For best performance, monitor 5A or more current. At currents less than 5A, these ranges are approximate.

1 Listed for use on 75°C insulated conductors.

**ACCESSORIES**

DIN Rail Clip Set (AH01)  
DIN Rail (AV01) and DIN Stop Clip (AV02)

