

Mini Multimeter  
with Non-Contact Voltage Detector (NCV)

Model EX310

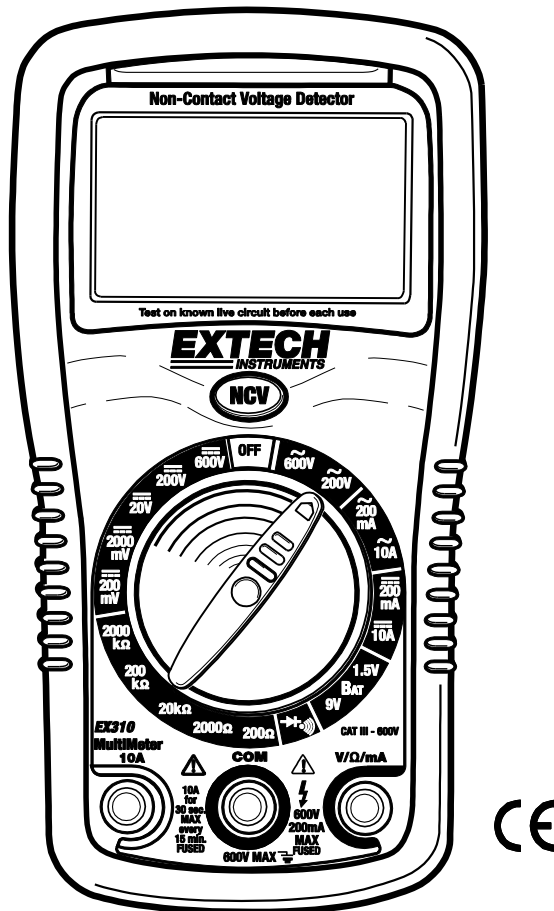

## Introduction

Congratulations on your purchase of the Extech EX310 MultiMeter. The EX310 offers AC/DC Voltage, AC/DC Current, Resistance, Diode, and Continuity testing plus a built-in non-contact Voltage Detector. Proper use and care of this meter will provide many years of reliable service. For copies of this user manual in other languages please visit the website.

## Safety

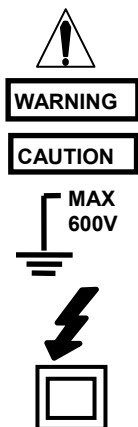

This symbol adjacent to another symbol, terminal or operating device indicates that the operator must refer to an explanation in the Operating Instructions to avoid personal injury or damage to the meter.

This **WARNING** symbol indicates a potentially hazardous situation, which if not avoided, could result in death or serious injury.

This **CAUTION** symbol indicates a potentially hazardous situation, which if not avoided, may result damage to the product.

This symbol advises the user that the terminal(s) so marked must not be connected to a circuit point at which the voltage with respect to earth ground exceeds 600V.

This symbol adjacent to one or more terminals identifies them as being associated with ranges that may, in normal use, be subjected to particularly hazardous voltages. For maximum safety, the meter and its test leads should not be handled when these terminals are energized.

This symbol indicates that a device is protected throughout by double insulation or reinforced insulation.

## Safety Instructions

This meter has been designed for safe use, but must be operated with caution. The rules listed below must be carefully followed for safe operation.

1. **NEVER** apply voltage or current to the meter that exceeds the specified maximum:

Input Protection Limits	
Function	Maximum Input
V DC or V AC	600V AC and DC
mA AC/DC	200mA DC/AC
A AC/DC	10A DC/AC (for 30 seconds max. every 15 mins.)
Resistance, Diode Test, Continuity	250V DC/AC

2. **USE EXTREME CAUTION** when working with high voltages.
3. **DO NOT** measure voltage if the voltage on the "COM" input jack exceeds 600V above earth ground.
4. **NEVER** connect the meter leads across a voltage source while the function switch is in the current, resistance, or diode mode. Doing so can damage the meter.
5. **ALWAYS** discharge filter capacitors in power supplies and disconnect the power when making resistance or diode tests.
6. **ALWAYS** turn off power and disconnect test leads before opening the covers to replace the fuse or battery.
7. **NEVER** operate the meter unless the back cover and the battery and fuse covers are in place and fastened securely.
8. If the equipment is used in a manner not specified by the manufacturer, the protection provided by the equipment may be impaired.

## CAUTIONS

- Improper use of this meter can cause damage, shock, injury or death. Read and understand this user manual before operating the meter.
- Always remove the test leads before replacing the battery or fuses.
- Inspect the condition of the test leads and the meter itself for any damage before operating the meter. Repair or replace any damage before use.
- Use great care when making measurements if the voltages are greater than 25VAC rms or 35VDC. These voltages are considered a shock hazard.
- Warning! This is a class A equipment. This equipment can cause interference to devices in the home; in this case the operator can be required to carry out adequate measures to prevent interference.
- Always discharge capacitors and remove power from the device under test before performing Diode, Resistance or Continuity tests.
- Voltage checks on electrical outlets can be difficult and misleading because of the uncertainty of connection to the recessed electrical contacts. Other means should be used to ensure that the terminals are not "live".
- If the equipment is used in a manner not specified by the manufacturer, the protection provided by the equipment may be impaired.
- This device is not a toy and must not reach children's hands. It contains hazardous objects as well as small parts that children could swallow. In case a child swallows any of the parts, please contact a physician immediately.
- Do not leave batteries and packing material unattended; they can be dangerous for children.
- In case the device is going to be unused for an extended period of time, remove the batteries to prevent them from draining.
- Expired or damaged batteries can cause cauterization on contact with skin. Always use suitable hand protection.
- See that the batteries are not short-circuited. Do not throw batteries into fire.

## Description

1. AC Voltage Detector Sensor
2. AC Voltage Detector indicator light
3. Display (LCD)
4. Non-contact AC Voltage Detector test button
5. Rotary function dial
6. 10 ampere test lead jack
7. COM test lead jack
8. Test lead jack for voltage, milliamp, resistance/continuity, and diode functions
9. Protective rubber holster (must be removed to access the rear battery compartment)

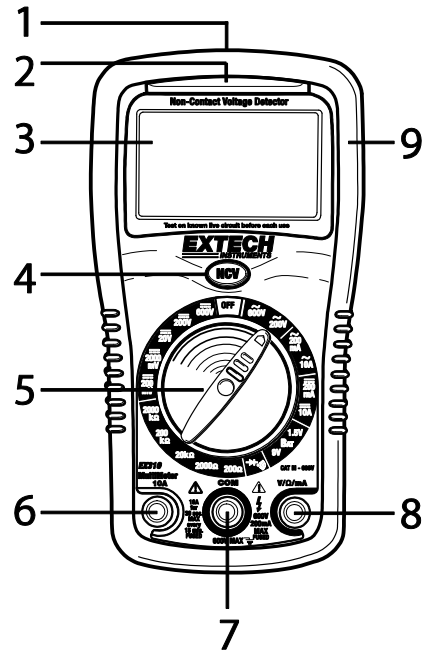

## Symbols

•)))	Continuity
▶	Diode
🔋	Battery status
~	AC
— — —	DC
m	milli ( $10^{-3}$ ) (volts, amps)
k	kilo ( $10^3$ ) (ohms)
V	Volts
A	Amps
$\Omega$	Ohms
AC	Alternating current
DC	Direct current

## Operating Instructions

**WARNING:** Risk of electrocution. High-voltage circuits, both AC and DC, are very dangerous and should be measured with great care.

**NOTE:** On some low AC and DC voltage ranges, with the test leads not connected to a device, the display may show a random, changing reading. This is normal and is caused by the high-input sensitivity. The reading will stabilize and give a proper measurement when connected to a circuit.

### NON-CONTACT AC VOLTAGE DETECTOR (NCV)

The EX310 can detect the presence of AC voltage (from 100 to 600VAC) simply by being held very near to a voltage source.

**WARNING:** Test the AC voltage detector on a known live circuit before each use.

**WARNING:** Before using the meter in the AC Voltage Detector mode, verify that the battery is fresh by confirming characters appear on the LCD when the function dial is turned to any position. Do not attempt to use the meter as an AC Voltage Detector if the battery is weak or bad.

The NCV function works on any rotary switch position.

1. Test the detector on a known live circuit before use.
2. Press and hold the NCV button for the duration of the test. The meter will beep once when the button is pushed and the battery icon will appear briefly before the display goes blank.
3. Hold the top of the meter very close to the voltage source as shown.
4. If voltage is present, the rim of the LCD display will flash a bright orange and an audible warning will sound.



## AC VOLTAGE MEASUREMENTS

**WARNING:** Risk of Electrocution. The probe tips may not be long enough to contact the live parts inside some 240V outlets for appliances because the contacts are recessed deep in the outlets. As a result, the reading may show 0 volts when the outlet actually has voltage on it. Make sure the probe tips are touching the metal contacts inside the outlet before assuming that no voltage is present.

**CAUTION:** Do not measure AC voltages if a motor on the circuit is being switched ON or OFF. Large voltage surges may occur that can damage the meter.

1. Set the function switch to the 600 VAC position.
2. Insert the black test lead banana plug into the negative **COM** jack. Insert red test lead banana plug into the positive **V** jack.
3. Touch the black test probe tip to the neutral side of the circuit.
4. Touch the red test probe tip to the "hot" side of circuit.
5. Read the voltage in the display.



## DC VOLTAGE MEASUREMENTS

**CAUTION:** Do not measure DC voltages if a motor on the circuit is being switched ON or OFF. Large voltage surges may occur that can damage the meter.

1. Set the function switch to the highest VDC position.
2. Insert the black test lead banana plug into the negative **COM** jack. Insert the red test lead banana plug into the positive **V** jack.
3. Touch the black test probe tip to the negative side of the circuit. Touch the red test probe tip to the positive side of the circuit.
4. Read the voltage in the display. Move the function switch to successively lower VDC positions to obtain a higher resolution reading.

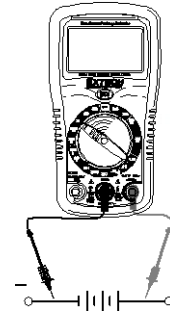

## BATTERY VOLTAGE TEST

**CAUTION:** Do not measure batteries while they are installed in the devices they are powering. The batteries must be removed from installations before tests can be made.

1. Set the function switch to the **1.5V** or **9V BAT** switch position. Use the 1.5V position for 'AAA', 'AA', 'C', 'D', and other 1.5V batteries. Use the 9V position for square 9V transistor batteries.
2. Insert the black test lead banana plug into the negative **COM** jack. Insert the red test lead banana plug into the positive **V** jack.
3. Touch the black test probe tip to the negative side of the battery. Touch the red test probe tip to the positive side of the battery.
4. Read the voltage in the display.



## AC / DC CURRENT MEASUREMENTS

**CAUTION:** Do not make current measurements at 10 Amps for longer than 30 seconds. Exceeding 30 seconds may cause damage to the meter and/or the test leads.

1. Insert the black test lead banana plug into the negative **COM** jack.
2. For current measurements up to 200mA AC or DC, set the function switch to the 200m AAC or ADC position and insert the red test lead banana plug into the **mA** jack.
3. For current measurements up to 10A AC or DC, set the function switch to the 10A AAC or 10A ADC position and insert the red test lead banana plug into the **10A** jack.
4. Remove power from the circuit under test, then open up the circuit at the point where you wish to measure current.
5. Touch the black test probe tip to the negative side of the circuit. Touch the red test probe tip to the positive side of the circuit.
6. Apply power to the circuit.
7. Read the current in the display.

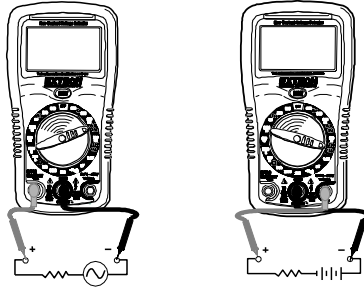

## RESISTANCE MEASUREMENTS

**WARNING:** To avoid electric shock, disconnect power to the unit under test and discharge all capacitors before taking any resistance measurements.

1. Set the function switch to the highest  $\Omega$  position.
2. Insert the black test lead banana plug into the negative **COM** jack.
3. Insert the red test lead banana plug into the positive  $\Omega$  jack.
4. Touch the test probe tips across the circuit or part under test. It is best to disconnect one side of the part under test so the rest of the circuit will not interfere with the resistance reading.
5. Read the resistance in the display. Move the function switch to successively lower  $\Omega$  positions to obtain a higher resolution reading.

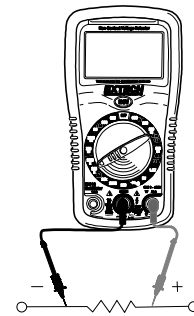



## CONTINUITY CHECK

**WARNING:** To avoid electric shock, never measure continuity on circuits that have a voltage potential.

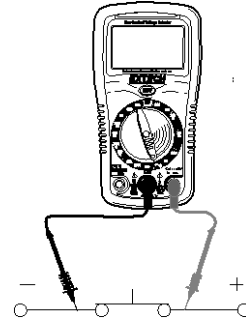
1. Set the function switch to the  position.
2. Insert the black lead banana plug into the negative **COM** jack.
3. Insert the red test lead banana plug into the positive  $\Omega$  jack.
4. Touch the test probe tips to the circuit or wire you wish to check.
5. If the resistance is less than approximately 100 $\Omega$  the audible signal will sound. If the circuit is open, the display will indicate "1\_\_\_".



## DIODE TEST

1. Set the function switch to the  position.
2. Insert the black test lead banana plug into the negative **COM** jack and the red test lead banana plug into the positive  jack.
3. Touch the test probes to the diode under test.
4. A good diode will indicate approx. 700 ohms for the forward test and "1\_\_\_" for the reverse test.
5. A shorted diode will indicate the same value of resistance in both the reverse and forward test directions. An open diode will indicate "1\_\_\_" in both test directions.

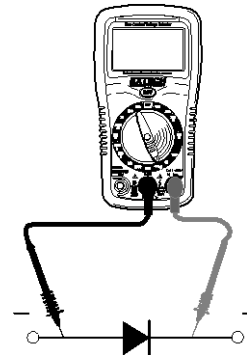

## ***Maintenance***

---

**WARNING:** To avoid electric shock, disconnect the test leads from any source of voltage before removing the back cover or the battery or fuse covers.

**WARNING:** To avoid electric shock, do not operate your meter until the battery and fuse covers are in place and fastened securely.

This MultiMeter is designed to provide years of dependable service, if the following care instructions are performed:

1. **KEEP THE METER DRY.** If it gets wet, wipe it off.
2. **USE AND STORE THE METER IN NORMAL TEMPERATURES.** Temperature extremes can shorten the life of the electronic parts and distort or melt plastic parts.
3. **HANDLE THE METER GENTLY AND CAREFULLY.** Dropping it can damage the electronic parts or the case.
4. **KEEP THE METER CLEAN.** Wipe the case occasionally with a damp cloth. DO NOT use chemicals, cleaning solvents, or detergents.
5. **USE ONLY FRESH BATTERIES OF THE RECOMMENDED SIZE AND TYPE.** Remove old or weak batteries so they do not leak and damage the unit.
6. **IF THE METER IS TO BE STORED FOR A LONG PERIOD OF TIME,** the battery should be removed to prevent damage to the unit.

## BATTERY INSTALLATION and LOW BATTERY INDICATION

**WARNING:** To avoid electric shock, disconnect the test leads from any source of voltage before removing the battery cover. Do not operate meter unless the battery cover is in place.

### LOW BATTERY INDICATION

The  icon will appear in the lower left-hand corner of the display when the battery voltage becomes low. Replace the batteries when this appears.

### BATTERY REPLACEMENT

1. Disconnect the test leads from the meter.
2. Remove the protective rubber holster. See diagram.
3. Remove the Phillips head screw located on the lower back of the instrument.
4. Remove the fuse/battery compartment cover to access the battery. See diagram.
5. Replace the 9V battery observing polarity.
6. Secure the fuse/battery compartment cover using the Phillips head screw.
7. Place the protective rubber holster on the meter.



Never dispose of used batteries or rechargeable batteries in household waste. As consumers, users are legally required to take used batteries to appropriate collection sites, the retail store where the batteries were purchased, or wherever batteries are sold.

**Disposal:** Do not dispose of this instrument in household waste. The user is obligated to take end-of-life devices to a designated collection point for the disposal of electrical and electronic equipment.

### Other Battery Safety Reminders

- Never dispose of batteries in a fire. Batteries may explode or leak.
- Never mix battery types. Always install new batteries of the same type.

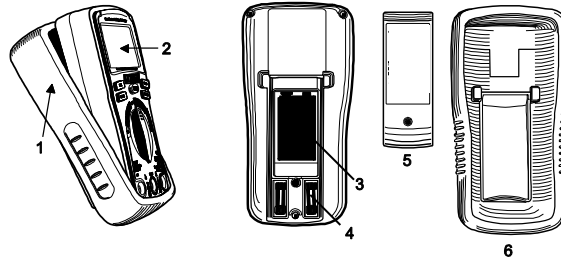

1. Removable Rubber Holster
2. Meter
3. Battery
4. Fuses
5. Compartment Cover
6. Rubber Holster

## REPLACING THE FUSES

**WARNING:** To avoid electric shock, disconnect the test leads from any source of voltage before removing the fuse cover.

1. Disconnect the test leads from the meter.
2. Remove the protective rubber holster.
3. Remove the Phillips head screw located on the lower back of the instrument.
4. Remove the fuse/battery compartment cover to access the fuses.
5. Gently remove the fuse(s) and install new fuse(s) into the holder(s).
6. Always use fuses of the proper size and value (200mA/600V fast blow for the mA /  $\mu$ A ranges, 10A/600V fast blow for the A range).
7. Secure the fuse/battery compartment cover.
8. Place the protective rubber holster on the meter.

**WARNING:** To avoid electric shock, do not operate your meter until the fuse cover is in place and fastened securely.

## Range Specifications

Function	Range	Resolution	Accuracy
Non-contact AC Voltage detector	100 to 600V	Resolution & accuracy do not apply since the meter does not display the voltage in this mode. The lamp at the top of the meter's display flashes when voltage is sensed and an audible warning will sound	
DC Voltage (V DC)	200mV	0.1mV	$\pm(0.5\%$ reading + 2 digits)
	2000mV	1mV	$\pm(1.0\%$ reading + 2 digits)
	20V	0.01V	
	200V	0.1V	
	600V	1V	$\pm(1.5\%$ reading + 2 digits)
AC Voltage (VAC) 50/60Hz	200V	0.1V	$\pm(1.5\%$ reading + 3 digits)
	600V	1V	$\pm(2.0\%$ reading + 4 digits)
DC Current (A DC)	200mA	0.1mA	$\pm(1.5\%$ reading + 2 digits)
	10A	0.01A	$\pm(2.5\%$ reading + 5 digits)
AC Current (AAC) 50/60Hz	200mA	0.1mA	$\pm(1.8\%$ reading + 5 digits)
	10A	0.01A	$\pm(3.0\%$ reading + 7 digits)
Resistance	200 $\Omega$	0.1 $\Omega$	$\pm(1.2\%$ reading + 4 digits)
	2000 $\Omega$	1 $\Omega$	$\pm(1.2\%$ reading + 2 digits)
	20k $\Omega$	0.01k $\Omega$	
	200k $\Omega$	0.1k $\Omega$	
	2000k $\Omega$	1k $\Omega$	

**Notes:** Accuracy specifications consist of two elements:

- (% reading) – This is the accuracy of the measurement circuit.
- (+ digits) – This is the accuracy of the analog to digital converter.

Accuracy is stated at 18°C to 28°C (65°F to 83°F) and less than 75% RH.

## General Specifications

---

<b>Diode Test</b>	Bias voltage: 2.3VDC
<b>Continuity Check</b>	Audible signal will sound if the resistance is less than 100Ω
<b>Input Impedance</b>	1MΩ (VDC & VAC)
<b>AC Bandwidth</b>	50 / 60Hz
<b>Display</b>	2000 count (0 to 1999) LCD
<b>Over-range indication</b>	"1____" is displayed
<b>Polarity</b>	Automatic (no indication for positive); Minus (-) sign for negative
<b>Measurement Rate</b>	2 times per second, nominal
<b>Low Battery Indication</b>	"  " is displayed if battery voltage drops below operating voltage
<b>Battery</b>	One (1) 9V battery
<b>Fuses</b>	mA range; 200mA/600V fast blow A range; 10A/600V fast blow, ceramic
<b>Operating Temperature</b>	0°C to 50°C (32°F to 122°F)
<b>Storage Temperature</b>	-20°C to 60°C (-4°F to 140°F)
<b>Operating Humidity</b>	Max 70% up to 31°C (87°F) decreasing linearly to 50% at 50°C (122°F)
<b>Storage Humidity</b>	< 80% RH
<b>Operating Altitude</b>	2000 meters (7000 ft) maximum.
<b>Weight</b>	260g (9.17 oz) includes holster
<b>Size</b>	147 x 76 x 42mm (5.8" x 2.9" x 1.6") includes holster
<b>Approvals</b>	CE
<b>Safety</b>	This meter is intended for indoor use and protected, against the users, by double insulation per EN61010-1 and IEC61010-1 3 <sup>rd</sup> Edition (2010) CAT III 600V; Pollution Degree 2.

### PER IEC1010 OVERVOLTAGE INSTALLATION CATEGORY

#### OVERVOLTAGE CATEGORY I

Equipment of OVERVOLTAGE CATEGORY I is equipment for connection to circuits in which measures are taken to limit the transient overvoltages to an appropriate low level. Note – Examples include protected electronic circuits.

#### OVERVOLTAGE CATEGORY II

Equipment of OVERVOLTAGE CATEGORY II is energy-consuming equipment to be supplied from the fixed installation.

Note – Examples include household, office, and laboratory appliances.

#### OVERVOLTAGE CATEGORY III

Equipment of OVERVOLTAGE CATEGORY III is equipment in fixed installations.

Note – Examples include switches in the fixed installation and some equipment for industrial use with permanent connection to the fixed installation.

#### OVERVOLTAGE CATEGORY IV

Equipment of OVERVOLTAGE CATEGORY IV is for use at the origin of the installation.

Note – Examples include electricity meters and primary over-current protection equipment