



Series DM-2000 Differential Pressure Transmitter

Specifications – Installation and Operating Instructions



The Dwyer Series DM-2000 Differential Pressure Transmitter senses the pressure of air and compatible gases and sends a standard 4-20 mA output signal. The DM-2000 housing is specifically designed to mount in the same diameter cutout as a standard Magnehelic® differential gage. A wide range of models are available factory calibrated to specific ranges.

Pressure connections are inherent to the glass filled plastic molded housing making installation quick and easy. Digital push-button zero simplifies calibration over typical turn-potentiometers. Single push button allows field selection of 5 engineering units (LCD models only). An optional 3.5 digit LCD shows process and engineering.

Accessories

Mounting Lugs
6-20 x 2" Screws - 3
6-19 x 1/2" Screws - 3

INSTALLATION

1. Location

Select a clean, dry mounting location free from excess vibration where the temperature will remain between 20 and 120°F (-6.7 and 48.9°C). Distance from the receiver is limited only by total loop resistance. See Electrical Connections on next page. The tubing supplying pressure to the instrument can be practically any length required, but long lengths will increase response time slightly.

2. Position

A vertical position required. That is the position in which all standard models are spanned and zeroed at the factory.

Pressure Connections

Two integral tubing connections are provided on the side of the gage. They are sized to fit 1/8" (3.12 mm) I.D. tubing. Be sure the pressure rating of the tubing exceeds that of the operating ranges.

Note: The tubing connections on the back of the gage are not to be used as process connections.

3. Mounting

Panel - Provide a 4-9/16" diameter opening in panel. Insert gage and secure in place with provided screws and adapters.

Surface - Provide three 3/16" diameter holes in panel on a 4-1/8" diameter bolt circle. Cut opening for terminal block as shown in diagram to right.

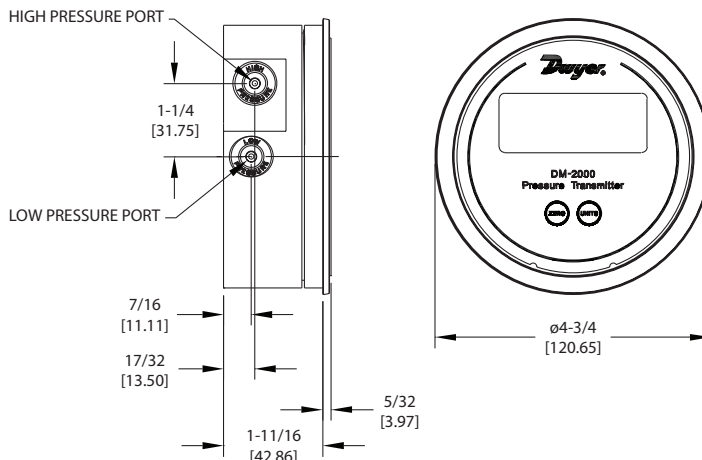

SPECIFICATIONS

Service: Air and non-combustible, compatible gases.

Wetted Materials: Consult Factory.

Accuracy: ±1% F.S. at 70°F.

Stability: ±1% F.S./yr.

Temperature Limits: 20 to 120°F (-6.67 to 48.9°C).

Pressure Limits: 10 psig (0.69 bar).

Thermal Effect: ±0.055% F.S./°F (0.0099% F.S./°C).

Power Requirements: 10-35 VDC (2 wire).

Output Signal: 4 to 20 mA.

Zero and Span Adjustments: Digital push-button zero and span.

Loop Resistance: DC: 0-1250 ohms maximum.

Current Consumption: DC: 38 mA maximum.

Electrical Connections: Screw-type terminal block.

Process Connections: 1/8" I.D. tubing.

Mounting Orientation: Vertical.

Weight: 4.8 oz (136 g).

Agency Approvals: CE.

Panel

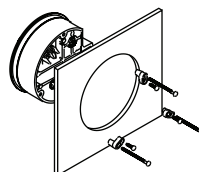

Surface

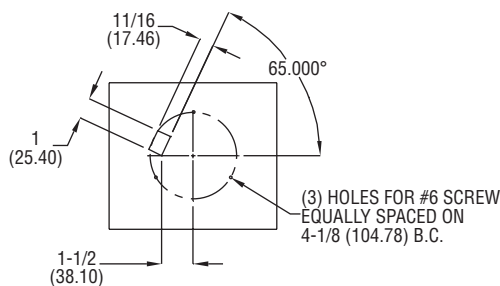

ELECTRICAL CONNECTIONS

CAUTION: Do not exceed specified supply voltage ratings. Permanent damage not covered by warranty will result. This unit is not designed for 120 or 240 volts AC line operation.

Electrical connections are made to the terminal block located in back of the transmitter. Terminals are marked + and - (see Fig. B below).

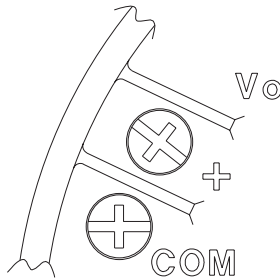

Figure B

Wire Length

The maximum length of wire connecting transmitter and receiver is a function of wire size and receiver resistance. Wiring should not contribute more than 10% of the receiver resistance to total loop resistance. For extremely long runs (over 1000 feet), choose receivers with higher resistance to minimize size and cost of connecting leads. Where wiring length is under 100 feet, hook-up wire as small as 22 AWG can be used.

2-Wire Operation

An external power supply delivering 10-35 VDC with minimum current capability of 40 mA DC (per transmitter) must be used to power the control loop. See Fig. C for connection of the power supply, transmitter and receiver. The range of appropriate receiver load resistance (R_L) for the DC power supply voltage available is expressed by the formula and graph in Fig. D. Shielded two wire cable is recommended for control loop wiring. If grounding is required, use the negative side of the control loop after the receiver.

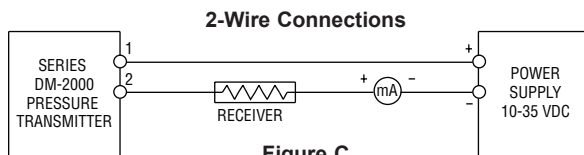

Figure C

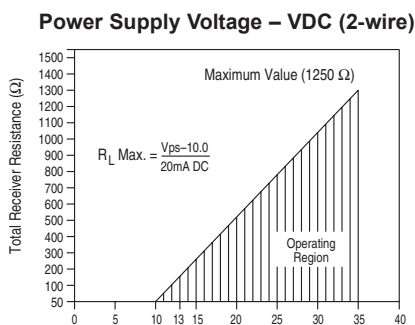

Figure D

USER CALIBRATION

The transmitter may be user calibrated with two buttons on the front. The standard models have buttons labeled “ZERO” and “SPAN”. LCD models have buttons labeled “ZERO” and “UNITS”. The “UNITS” button on the LCD models has 2 functions. If pushed for less than 2 seconds and released the pressure units that are displayed on the LCD will change when the button is released. If pushed and held for 4 - 5 seconds the “UNITS” button serves the same function as the “SPAN” button on the standard models.

To calibrate the transmitter you will need three pieces of equipment. You will need a calibrated pressure source capable of generating a stable pressure value for the maximum range of the unit under test, an instrument capable of validating the calibration pressure, and a milliammeter to measure the current output from the unit under test. The transmitter is calibrated using the following procedure.

Preparation – Connect the Milliammeter and power supply, being careful to observe polarities. The transmitter must be calibrated in a vertical position.

Calibrating Zero – Leaving the pressure connections vented, press and hold the “ZERO” button for 4 – 5 seconds. The zero point will now be set and the gage output will be 4 mA and if it is an LCD model the display will read zero. This zero calibration is done first as it can affect the span value.

Calibrating Span – Connect the pressure source and apply the high range rated pressure. When the pressure has stabilized, press and hold the “UNITS” button (for LCD models), or the “SPAN” button (on standard models), for 4 – 5 seconds. The span point will now be set and the gage output at full range will be 20 mA and if it is an LCD model will now read the full range calibration pressure. The zero and span setting are slightly interactive so recheck the zero calibration and repeat both zero and span calibration if necessary.

Restoring Factory Calibration Coefficients:

The user calibration coefficients are stored in non volatile memory, which retains its content indefinitely without external power or batteries. Factory calibration can be easily restored if the user calibration must be “erased”. To do this simultaneously press both buttons on the front and hold them for 4 – 5 seconds. The factory calibration will now be restored.

MAINTENANCE

Upon final installation of the Series DM2000 Differential Pressure Transmitter and the companion receiver no routine maintenance is required. A periodic check of the system calibration is recommended following the procedures explained under Calibration Check. The Series DM2000 Transmitter is not field serviceable and should be returned, freight prepaid, to the factory if repair is required. Please enclose a description of the problems encountered plus any available application information.