



Eagle Eye Power Solutions, LLC
Keeping an Eye on Your Critical Power!

BDS-Pro

Battery Monitoring System

Installation Manual V1.1



Contents

1. Introduction.....	3
1.1 Safety Information.....	3
2. Product Overview.....	4
2.1 Main Processing Unit (MPU).....	5
2.2 Technical Specifications.....	7
3. Parts List	8
4. Installation Tools.....	10
4.1 Required Tools	10
4.2 Recommended Tools	11
5. Hardware Installation	12
5.1 Overview of Workflow	12
5.2 MPU Installation	13
5.3: Clamp Installation	14
5.4 Sensing Cable Layout & Connection	17
5.5 Temperature Sensor Connection	22
5.6 DC Voltage Cables	23
5.7 Connect DC CT Clamp	25
5.8 Verify Connections.....	27
5.9 Connect Cables to BDS-Pro MPU	29
6. Initial Power Up.....	30
6.1 Status LEDs.....	30
6.2 Keypad Operation	31
7. Parameter Setup & Measurement Verification	32
8. Network Communication Setup	37
8.1 Configure MPU IP Address.....	37
8.2 Connect BDS-Pro to Network.....	39
9. Sample Connection Diagrams:	40
10. Sales & Support	44



1. Introduction

This manual provides guided steps on how to install the Eagle Eye BDS-Pro Battery Monitoring System safely and effectively. Please read this manual carefully to fully understand the functionality of the BDS-Pro.

1.1 Safety Information

Operation methods and safety measures described in this manual are only applicable to the defined purpose and functionality of the BDS-Pro. If the BDS-Pro is used in a way not specified in this manual, the safety of the equipment, personnel, and property cannot be assured.

- Please read this manual carefully to avoid accidental injury or misuse of product.
- Only qualified personnel with proper tools and equipment should work on batteries.
- To avoid damage and injury due to the short circuiting of battery terminals, wrap insulating tape around all metallic parts.
- Do not wear metallic items such as jewelry, watches, & rings. Wear insulated gloves and goggles when working around batteries.
- Ensure an installation supervisor is on hand when connecting the BDS-Pro and battery post to avoid fire or personal injury.
- Make sure all personnel are fully aware of safety guidelines.





2. Product Overview

The BDS-Pro is designed to monitor and analyze the state of health of up to (24) cells by measuring and recording:

String: Voltage & DC Float / Discharge Current

Jar/Cell: Voltage, Internal Resistance / Connection Resistance, & Temperature

All BDS-Pro solutions come complete with battery management software which allows all battery systems to be monitored 24 hours a day, 365 days a year via remote computer(s). This software offers comprehensive battery diagnosis and reporting capabilities to ensure the integrity of your critical backup power system.

Alternatively, systems can be configured for Modbus communication for integration to a third-party building management system or SCADA (supervisory control and data acquisition).

The BDS-Pro is composed of the MPU (main processing unit), Sensing Cables, Connection Clamps, & CT.

2.1 Main Processing Unit (MPU)

The MPU receives battery data and communicates with the Server.

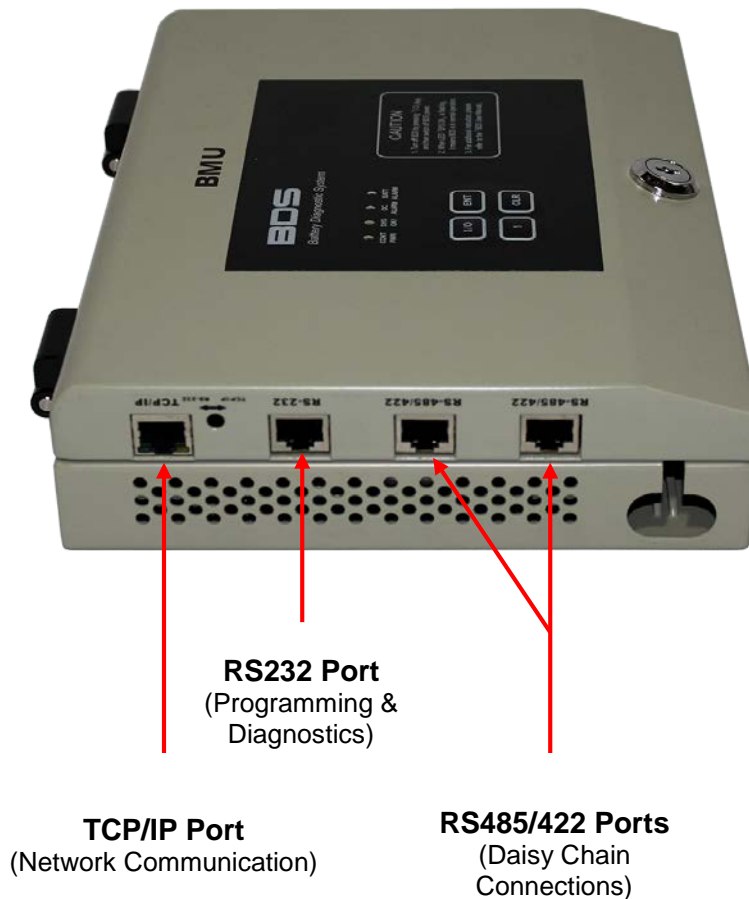

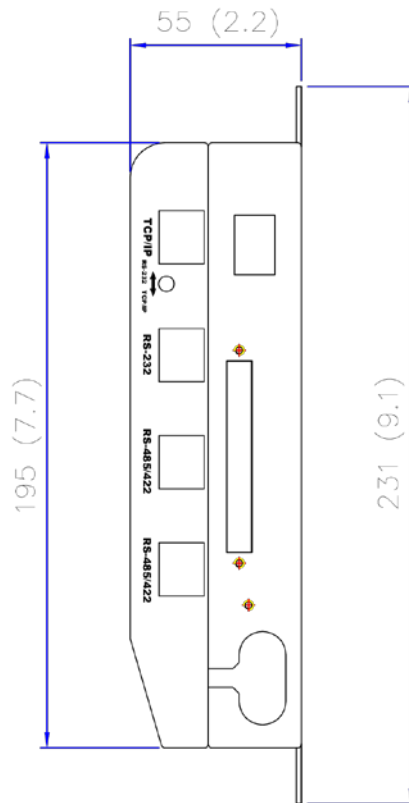
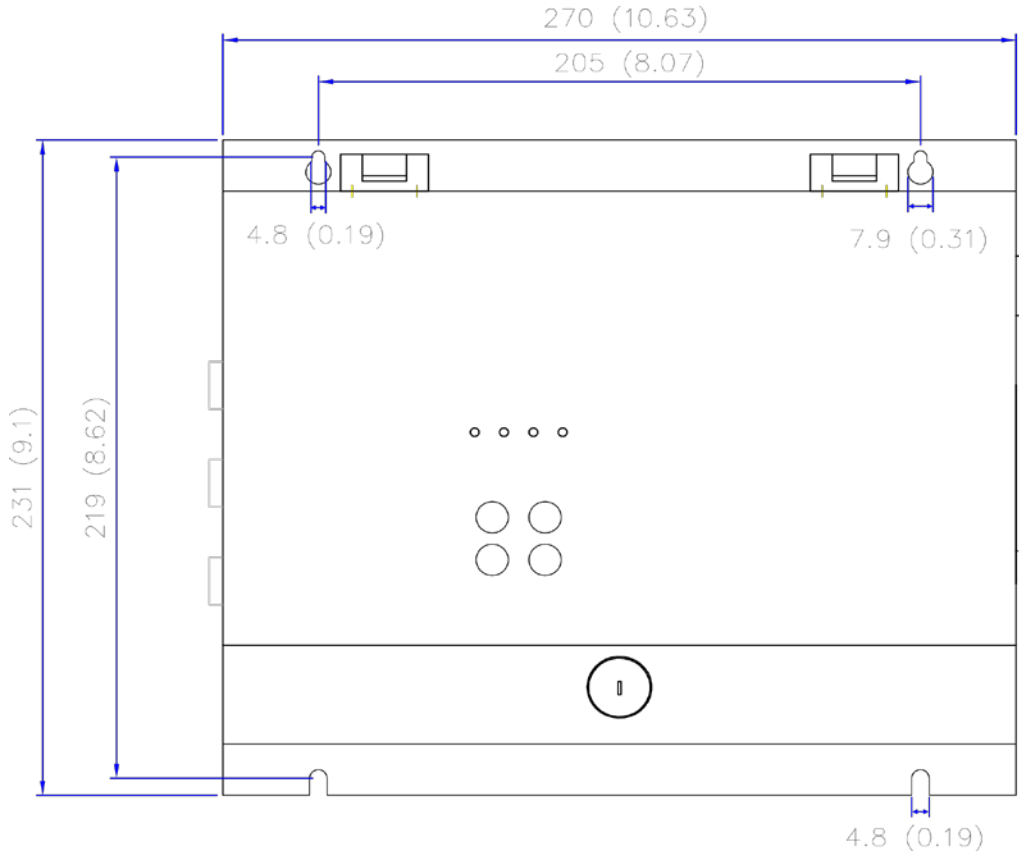













2.2 Technical Specifications

Applications:	Flooded, Sealed, & NiCad battery types Up to 24 jars / cells.
Battery Capacity Range:	Up to 6000 Ah
Cell Voltage:	1 – 16 VDC
Accuracy:	DC Voltage / Current: $\pm 0.5\%$ / $\pm 1\%$ Temperature: $\pm 2\%$ Internal Resistance: $\pm 2\%$ Cell Voltage: $\pm 1\%$
Resolution:	AC Voltage / Current: 0.1 V / 0.1 A DC Voltage / Current: 0.1 V / 0.1 A Cell Voltage: 10 mV Internal Resistance: 0.001 Ω Temperature: 0.5 $^{\circ}\text{C}$
Test Speed:	3 – 4 seconds per cell
Test Load:	< 2 A per cell
Display:	LED Indicator Lights
Internal Storage:	Limited On-board memory
Measuring Interval:	Adjustable from 10 min to 24 hours (voltage & resistance)
Data Transfer:	TCP/IP, Modbus Protocol
Bandwidth Use:	< 10 Kbps
Operating Environment:	Temperature: 0 – 50 $^{\circ}\text{C}$ (32 – 122 $^{\circ}\text{F}$) Relative Humidity: Under 80% RH
AC Power Requirements:	110 – 220 VAC, 50/60 Hz
DC Power Requirements:	48V: 43 – 72 VDC 125V: 100 – 150 VDC
Power Consumption:	15 W
Connections:	RJ45
Dimensions L x W x D:	MPU: 231 x 270 x 55 mm (9.1 x 10.6 x 2.2 in)

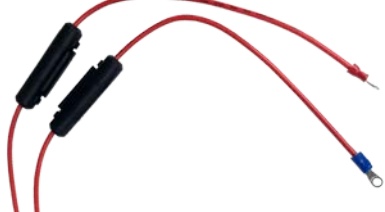
3. Parts List







The following parts come standard with each BDS-Pro package. The number and type of connector clamps will depend on the application.

Part Name & Purpose	Picture
<p>BDS-Pro MPU Main processing unit for BDS-Pro system</p>	
<p>C-Type Clamp Clamp used for connection between batteries with busbar inter-cell connections</p>	
<p>O-Type Clamp Clamp used for connection between batteries with cable inter-cell connections</p>	
<p>Clamp Covers: C-Type / O-Type Placed over clamp PCB</p>	
<p>CT Clamp Measures DC current</p>	

<p>AC / DC Power Cable Power cable for systems utilizing AC power</p>	
<p>Total Voltage / DC Power Fuses Fused lines between the Total Voltage & DC Power cables</p>	
<p>Total Voltage Jumpers Allows total voltage measurement from DC power terminations</p>	
<p>CT Cable Harness For connection between CT & BDS-Pro MPU</p>	
<p>Temperature Cable Harness (4-pin) Measures temperature of battery posts</p>	
<p>Voltage Sensing Cable Harness (6-pin) Measures DC voltage (Vs)</p>	
<p>Current Sensing Cable Harness (4-pin) Measures current (Is)</p>	

4. Installation Tools

4.1 Required Tools

Tool Name & Purpose	Picture
<p>Multi-meter Verification of connection voltage & resistance</p>	
<p>#1 Phillips Insulated Screwdriver Tightening of O-Type/C-Type clamp screws</p>	
<p>2/16" (2-3 mm) Flathead Screwdriver Tightening of sensing cable</p>	
<p>Wire Cutter Adjustment of cable length</p>	
<p>US or Metric Socket Set For mounting BDS-Pro</p>	
<p>Wire Stripper Adjustment of cable length</p>	

<p>Shop Snips Adjustment of duct length, cable length</p>	
<p>Zip Ties Cable management</p>	
<p>Cable Duct / Panduit Cable routing</p>	
<p>Electrical Tape (Scotch Super 33+ Recommended) Cable management</p>	
<p>Cable Wrap Bind multiple cables together</p>	

4.2 Recommended Tools

Tool Name & Purpose	Picture
<p><u>IBEX Battery Tester</u> Verification of BDS-Pro measurement readings</p>	

5. Hardware Installation

This section will provide the correct workflow for installing the BDS-Pro Battery Monitoring System and all of its components.

All necessary cables and clamps are provided at correct quantities and lengths based on information provided from the Site Survey. Please be sure to have all the necessary tools and parts listed in Section 3 and 4.

NOTE: This guide should be used as an outline for installation, however it does not cover every aspect of installation step-by-step. It is recommended that experienced personnel familiar with electrical work and battery-room environments perform this installation. If a section of this guide is unclear, please contact Eagle Eye Power Solutions directly for further support.

5.1 Overview of Workflow

The following is an overview of the complete workflow of what needs to be done on-site for the BDS-Pro Installation:

1. **Mount BDS-Pro MPU (Main Processing Unit) and Relaying Units**
2. **Install clamps to battery connections**
3. **Lay all sensing cables from the Relaying Unit to the clamps**
4. **Install temperature sensors**
5. **Connect total voltage cable and power connections**
6. **Install CT clamp**
7. **Verify all connections**
8. **Configure Parameters on the BDS-Pro menu screen**
9. **Configure BDS-Pro MPU IP address**
10. **Connect BDS-Pro to Network (if applicable)**

5.2 MPU Installation

Parts:	Main Processing Unit, Mounting Blocks
Tools:	Screwdriver, Socket Set, Drill

(1) Mount MPU Identify mounting locations (ex. battery rack, wall behind battery rack)

- The MPU should be mounted in the location which was determined during the Site Survey process. This location is typically indicated on the provided connection map



BDS-Pro Mounted to Wall

TIP: All sensing cables are factory cut to lengths based on the MPU location from the cable connection map.

5.3: Clamp Installation

Parts:	C-Type/O-Type Clamps
Tools:	Drill/Phillips Screwdriver

The BDS-Pro includes clamps for installation to the inter-cell connections of the battery system. There are two clamp types:





C-Clamp: Metal clamp which connects to the battery bus bars or terminal plate

O-Type: Plastic clamp which connects to cables (typically between rack tiers)

The purpose of the clamps is to provide a non-intrusive, fused connection to the battery system for measurement. The fuses are housed on a small PCB on each clamp. The placement of the clamps is based on the PCB type. There are two types of PCBs:

Voltage (Vs): Houses a 1A fuse only for voltage measurement

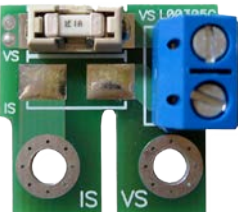
Current (Is): Houses a 1A fuse for voltage measurement in addition to a 3A fuse for current

Clamp Type		PCB Type	
			
C-Type for Busbar	O-Type for Cable	Voltage: (Vs) (1 fuse)	Current: (Is) (2 fuse)

(1) Prepare For Connection

1. Organize clamps based on type and verify all clamps are present
2. Reference the provided connection map to determine where each clamp is placed on the system

(2) Connection of Clamps (C-Type)

1. Connect clamps according to the provided connection map.
2. Determine how the clamp will be placed. Generally, the cable terminations should be facing the direction the sensing cable(s) will be ran from
3. Place the clamp in the center of the busbar and tighten down using the provided screws
4. If the busbar has a cover, cut out an area so the cover sits snugly against the clamp
5. Attach additional clamps, keep the direction and placement of all clamps consistent

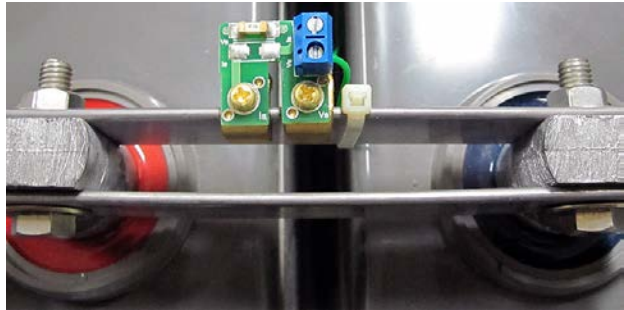

C-Type Clamps Installed to Busbars

(3) Connection of Clamps (O-Type)

1. Connect clamps according to the provided connection diagram.
2. Determine how the clamp will be placed. Generally, the cable terminations should be facing the direction the sensing cable(s) will come from
3. Place the clamp over the center of the cable and tighten the screws into the cable
NOTE: If the cable is too large for the clamp it can cut down to accommodate the size
4. Attach additional clamps, keep the direction and placement of all clamps consistent

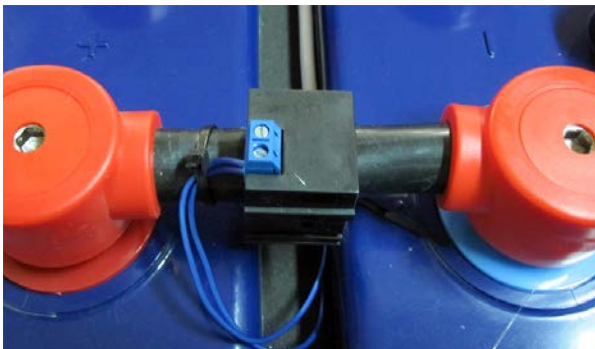
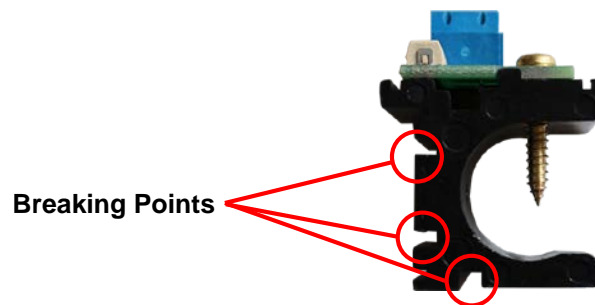

O-Type Clamp Connections

5.4 Sensing Cable Layout & Connection

Parts:	Voltage Sensing Harness, Current Sensing Harness, Connection Map
Tools:	2/16" (2-3mm) flathead, duct, cable ties/zip ties, wire cutter, wire stripper

The sensing cables must be laid out from the MPU to each individual connection (C-Clamp or O-Clamp) on the battery system. It is highly recommended to follow the cable connection map provided with the system while performing this step.

There are two labeled sensing cable harnesses which connect to the clamps: Voltage Sensing (**V**) & Current Sensing (**I**). Each cable harness is split into smaller color-coded wires.



6-Pin Voltage Sensing Cable



4-Pin Voltage Sensing Cable

(1) Sensing Cable Overview

Prior to installing the sensing cables it is important to understand the differences between the cable types and how they are installed.

Voltage sensing cable:

Voltage sensing cables measure cell voltage and connect to each clamp in the following order per harness from left to right:

Grey, Green, Blue, Orange, Brown

Example:

Clamp #1 = Grey

Clamp #2 = Green

Clamp #3 = Blue

Clamp #4 = Orange

Clamp #5 = Brown + Grey

Clamp #6 = Green

The last wire (brown) of the harness will always connect to the same (Vs) termination of the first wire (grey) of the next harness. Below is an illustration of the voltage sensing cable connection color sequence:

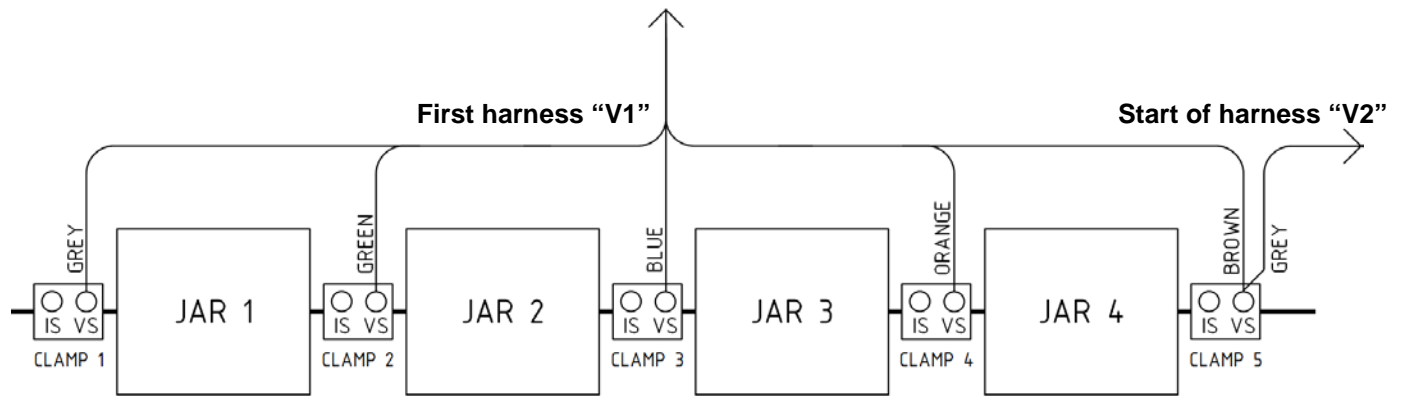

Current Sensing Cable:

Current sensing cables measure cell resistance and connect to specific clamps only (the placement of clamps varies depending on the system) in the following order from left to right:

Black, Red, White

Example: (for installation to 48V system with (24) 2V cells)

Clamp #1 = Black

Clamp #13 = Red

Clamp #25 = White

The last wire (white) of the harness will always connect to the same (IS) termination of the first wire (black) of the next harness if multiple harnesses are used. Below is an illustration of the current sensing cable connection color sequence:

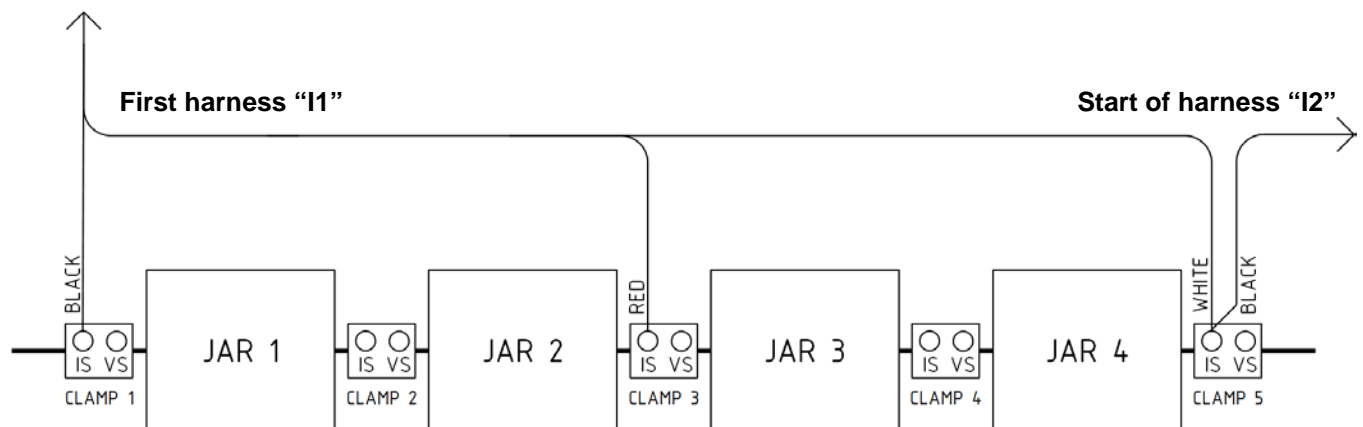

(2) Prepare Cable Routing

1. The first step to installing the sensing cabling is to plan the routing of the cabling. Sensing cables are provided in lengths based on information determined from the site survey process.
2. Start by securing the connector ends of the sensing cables to the BDS MPU by running the cable up into the MPU and fastening it using a zip-tie or tape as shown below:



WARNING: Do not connect any cables to clamps yet, wait until all cables are laid out and the steps to verify voltage have been completed.

(3) Install Cable Duct

1. For a clean installation it is recommended to route cables efficiently using cable ducts that are properly measured for the battery system
2. Mount cable ducts along all areas that sensing cables will be laid out
3. Be sure not to attach the cable ducts in a manner that will not prevent batteries from being removed during replacement (Ex. Laying cable ducts across front facing battery systems)



Duct Installation on (8) 6V Jars

NOTE: Cable ducts are included with Eagle Eye serviced installations. If performing the installation without Eagle Eye, ducts must be purchased separately.

(4) Lay Sensing Cables to Each Clamp

1. At this point the connector end of the cables should be secured at the MPU
2. Run the sensing cables from the MPU to the battery string
3. **Starting with the voltage (V) sensing cables**, lay each colored cable in the correct sequence 4 to 6 inches past each clamp so that there is some slack once the cable is connected (Ex. Grey→Clamp 1, Green→Clamp 2, Blue →Clamp 3, Orange→Clamp 4, Brown+Grey→Clamp 5)
4. **Next lay all current (I) sensing cables** in the correct sequence 4 to 6 inches past each clamp (I.e. Black→Clamp 1, Red→Clamp 13, White→Clamp 25)
5. For all clamps with multiple cables running to them, twist the cables together to minimize exposed cabling

(5) Connect Sensing Leads to Clamps

1. Observe carefully which slot to is used for each sensing cable

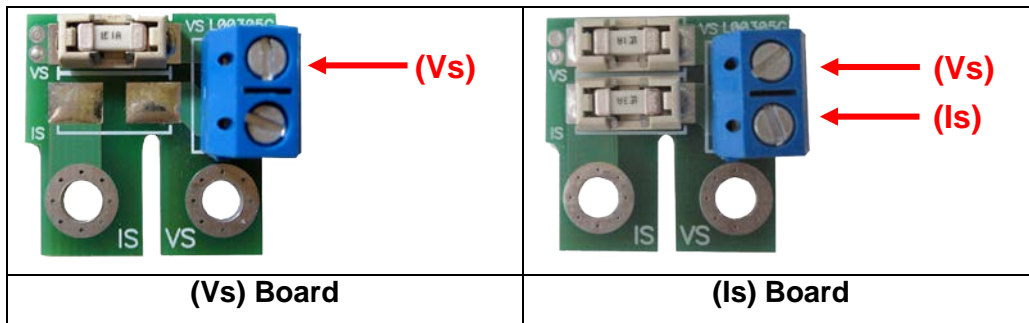

2. Using a wire stripper, cut ¼” (4mm) of shield away from the wire
3. Twist the exposed wire together, then fold in half and attach to appropriate termination on the clamp
4. Screw the cable tight using a 2/16” (2-3mm) flathead, firmly pull on the cable to ensure the connection is tight, ensure that none of the cable is exposed.

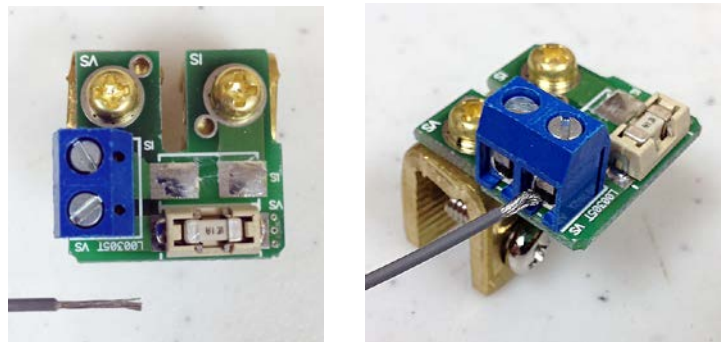

Connection of (Vs) Cable to C-Type Clamp

5.5 Temperature Sensor Connection

Parts:	Temperature (T) Cable Harness, Thermistor(s)
Tools:	Tape, Hot Glue Gun, or Silicone

(1) Connect Thermistor to Temperature Sensing Cable(s)

1. The temperature sensing cable harness has a red and black wire
2. Connect both the red and black wires to the (2) wires coming off the thermistor using the provided electrical splice connectors

(2) Adhere Temperature Leads

1. The temperature thermistor should be mounted close the negative post of the jar/cell according to the provided connection diagram. Generally, these leads can be placed on any jar/cell
2. Adhere the thermistor as close to the post as possible using tape to hold the lead in place, then use hot glue or silicone to fasten the lead

WARNING: Do not adhere the thermistor directly to the lead of any post or any surface that experiences high temperatures during charge / discharge cycles.

NOTE: It is recommended to contact the battery manufacturer prior to using silicone or other adhesive substances on the battery jar.

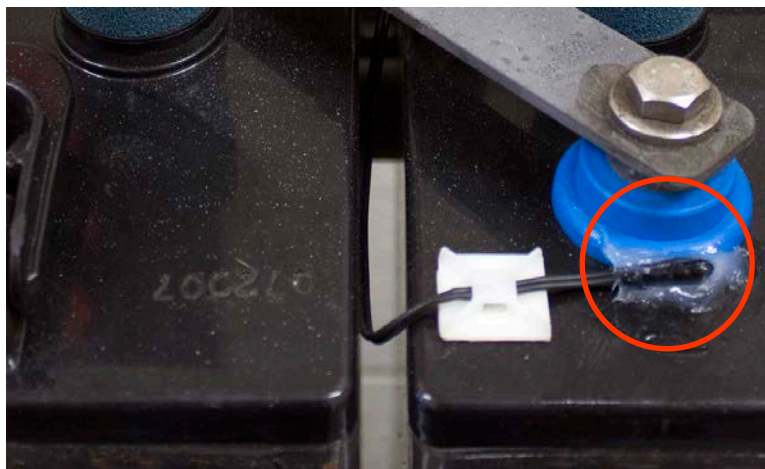

Secured Temperature Thermistor

5.6 DC Voltage Cables

Parts:	DC Voltage Cables, DC Voltage Fuses, Total Voltage Jumpers, Electrical Splice Connectors
Tools:	Phillips Screwdriver, Cable Crimper, Zip Ties

The DC Voltage Cables power the BDS-Pro as well as monitor string voltage in real-time. The cables connect to the main positive and negative bus of the battery system then back to the terminal block on the BDS-Pro MPU. Small jumpers on the terminal block are for string voltage measurement. Each voltage cable has a 250V/1A fuse for voltage protection. Be sure to check the fuse before installation.



1A Fuse Leads



Total Voltage Jumpers

(1) Splice Fuses to the DC Voltage Cable

1. Crimp the positive fuse to positive DC voltage cable
2. Crimp the negative fuse to the negative DC voltage cable



Crimp Fuse to Cable

(2) Connect to Battery System

1. Determine the best place to connect the DC voltage cables on the most positive and negative bus of the string
2. If using busbar connections, use the C-Clamp to connect to the busbar
3. If using cable connections, connect directly to the O-type clamp under the (Vs) screw that goes into the cable

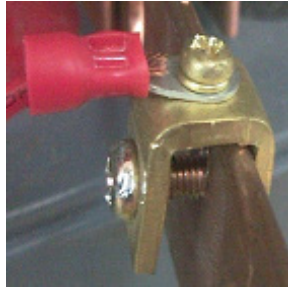

Total Volt. C-Clamp

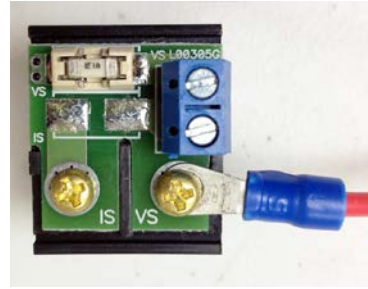

Total Voltage O-Clamp

(3) Connect DC Voltage Cables to BDS-Pro MPU

1. The DC voltage cables connect to the terminal block on the BDS-Pro
2. Connect the positive and negative DC voltage cable together with the total voltage jumper cables as shown below:

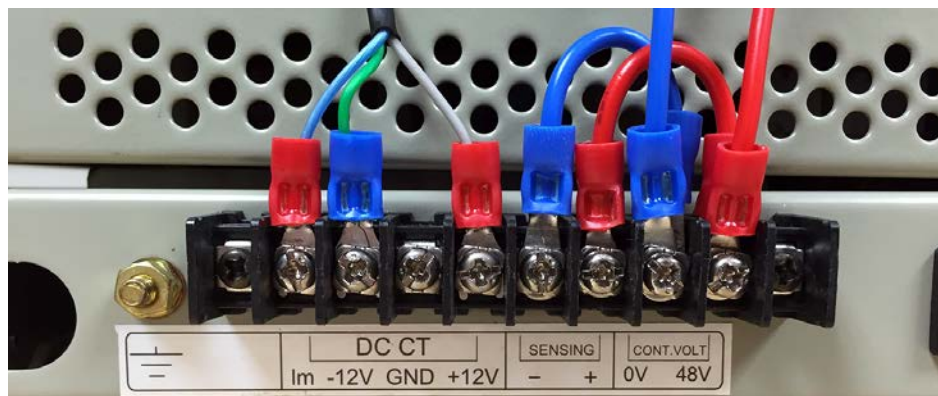
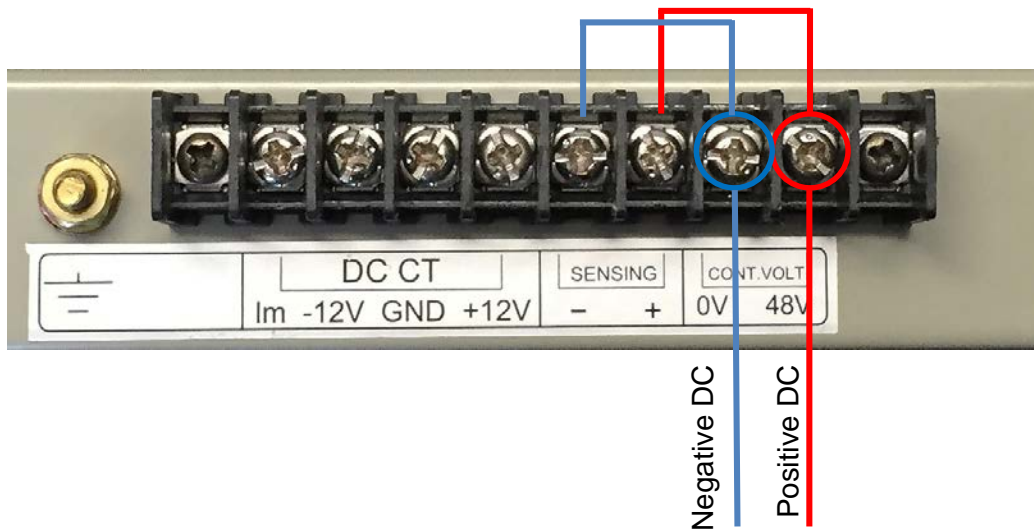

DC Voltage Cables Connected with Total Voltage Jumpers

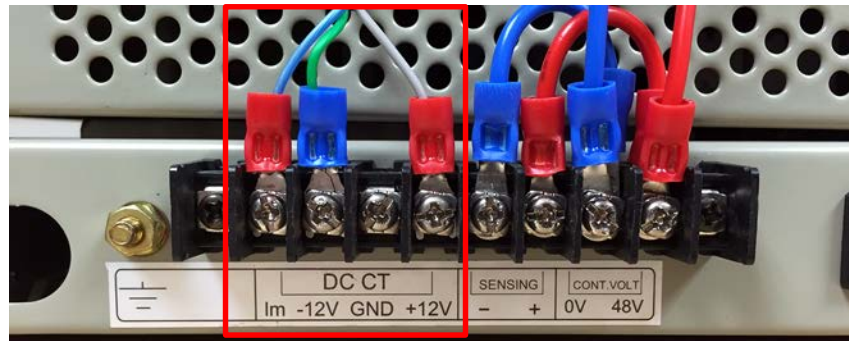

(3) Connect CT Cable Harness to CT Clamp

1. Cut excess length from the CT cable if needed
2. Remove shielding to expose roughly 2 inches of the colored wires
3. Cut about 3 mm of shielding from each individual wire
4. Connect the colored wires to each termination labeled [1], [2], and [3] as shown below. Be sure to connect the cables properly to avoid damaging the CT.

WARNING: Failure to connect the cables properly can damage the CT. If the CT is hot, making noise, or the current readings are irregular it is likely the CT was installed incorrectly.

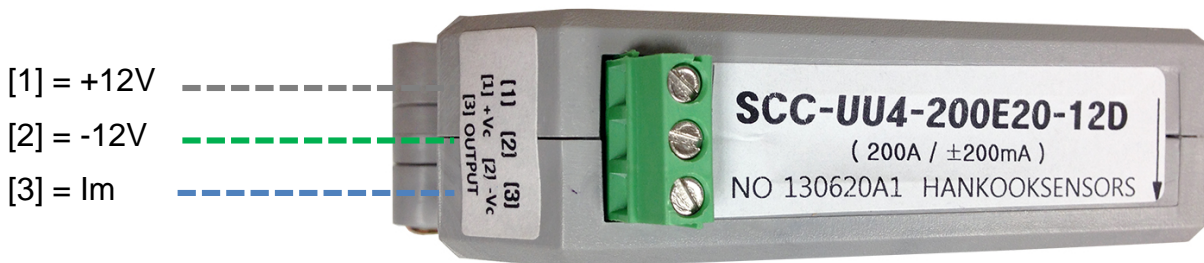

Labeled Cable Termination on CT

5.8 Verify Connections

Parts:	N/A
Tools:	Multimeter

Before plugging cable connectors into the MPU, be sure to check each connection using an accurate multimeter to verify the voltages. The purpose of this step is to ensure that the voltage of each connection is as expected. Higher or lower voltages signify that there is an improper connection on the battery system.

WARNING: Failure to perform the below steps may result in permanent damage to the battery monitoring system.

(1) Check Voltage & Current Sensing Connections

1. Always start with the first (Vs) connector cable that will plug into the MPU, this will always be cable "V1"
2. With the Molex connector end of the cable in hand, insert the positive lead from the multi-meter into the port with the grey cable
3. Insert the negative test lead into the green port
4. The multi-meter should display the same voltage as jar 1



Test Connection between Clamp 1 & Clamp 2 of 12V Cell

5. Move the negative test lead down the connector and verify each connection's voltage
6. The 5th connection should read the total voltage of the batteries it is connected to
7. Repeat the same steps for **all** (Vs) and (Is) connections



Test Connection between Clamp 1 & Clamp 5 of 12V Cells

(3) Troubleshooting Incorrect Voltage

1. If voltage is incorrect, connections will need to be checked
2. Set the multi-meter to measure resistance and test the connection between the sensing screw and the sensing cable
3. If the multi-meter displays zero resistance (0.00Ω) then the connection is good. If the connection has resistance, replace the fuse (1A)

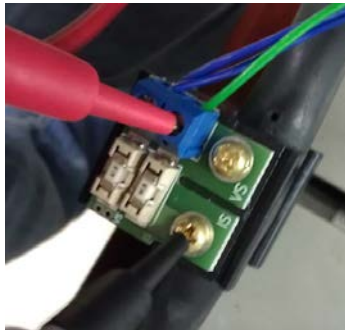

Check to Verify Fuse

(4) Check Temperature Sensor

1. Temperature sensors can be checked using resistance
2. Check connection resistance between each set of cables
3. The resistance should be around 10-11 mΩ

5.9 Connect Cables to BDS-Pro MPU

Parts:	N/A
Tools:	Zip/Cable Ties, Tape

The voltage, current, and temperature sensing cables connect the Relay Board located inside the BDS-Pro MPU.

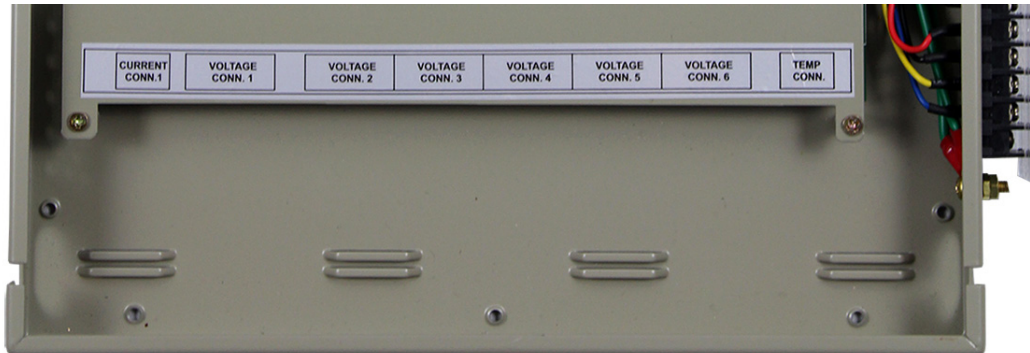

Relay Board Connections for Sensing Cables

(1) Connect all Sensing Cables to the MPU Relay Board

1. The MPU has (3) types of connections
 - a. "Current Conn." refers to connections for the (I) cabling (I1, I2, etc.)
 - b. "Voltage Conn." refers to connections for the (V) cabling (V1, V2, etc.)
 - c. "Temp Conn." refers to the connections for temp. sensing cable
2. Each numbered cable connects to a corresponding plug in MPU. For example cable "I1" connects to "Current Conn. 1" Inside the MPU, V1 connects to "Voltage Conn. 1" inside the MPU.
3. Connect all (Vs) and (Is) cables in ascending order (I1, then I2, then V1, V2, etc.)

6. Initial Power Up

After the installation of the BDS-Pro hardware is completed, the unit can be powered on. Prior to powering on the unit for the first time, double check the following items:

1. All clamps are connected in the correct order per the cable connection map
2. All cables are connected in the proper sequence per the cable connection map
3. The CT clamp is facing the correct direction
4. All voltages have been verified from the sensing cables, including current, voltage, and total voltage

WARNING: Failure to check the voltages of each sensing cable can result in permanent damage to the MPU. Ensure that all voltages are correct before powering on.

To power on the BDS-Pro, flip the power switch to the on position, the LED's on the front of the unit should illuminate.

6.1 Status LEDs

The BDS-Pro MPU has (4) status LEDs:



CONT PWR:

- Solid green LED indicates MPU is powered on

SYS OK!:

- Blinking green LED indicates normal operation
- Solid green LED indicates abnormal operation - contact EEPS
- Solid red LED indicates communication error – check Ethernet cable

DC ALARM:

- Blinking red LED indicates alarm for string measurement – see Section 7
- Blinking green indicates string measurements are OK

BATT ALARM:

- Blinking red LED indicates alarm for jar/cell measurement – see Section 7
- Blinking green indicates jar/cell measurements are OK

NOTE: It is likely that for the initial power up the DC and BATT alarms will be blinking. The steps in Section 7 should resolve this.

6.2 Keypad Operation

The BDS-Pro has a keypad for basic operation:

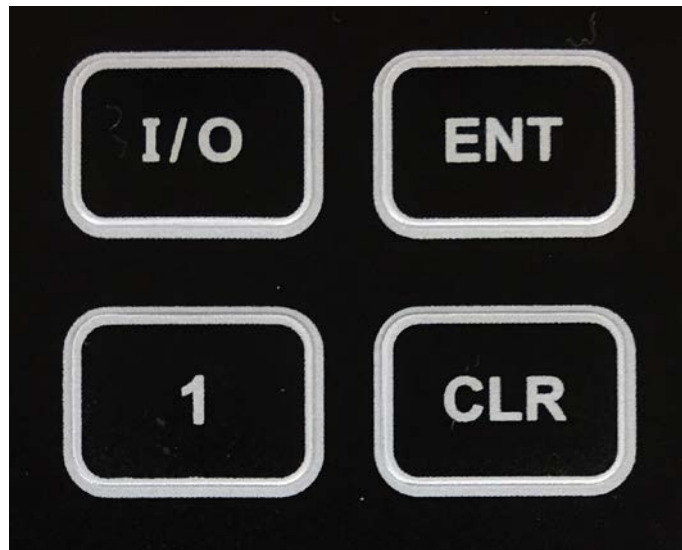
**I/O:**

- Hold with ENT to START measurement (unit will start clicking)
- Hold with ENT to STOP measurement (unit will click once)

ENT:

- Hold with I/O for the above operations

1:

- Factory diagnostic use only

CLR:

- Release alarm if not done automatically after adjusting parameters

7. Parameter Setup & Measurement Verification

Parts:	N/A
Tools:	Laptop, RJ45-USB adapter, EEPS USB drive

After the hardware installation of the BDS-Pro is complete the unit should be programmed and tested on-site. During this step, the program BDS-Serial Com will be used to set parameters on the BDS as well as view measurement data to ensure the unit is operating properly.

(1) Install BDS-Serial Com

1. Install *BDS_SerialCom_Setup.msi* from the provided USB drive

NOTE: You may need to run *setup.exe* from the BDS-Pro Serial Com folder if .NET Framework 4.0 or higher is not installed on the PC.

(2) Connect the Laptop to the BDS-Pro

The BDS-Pro connects to the PC/laptop using an RJ45-RS232-USB adapter cable.



1. Connect the cables together at the RS232 ends
2. Connect the RJ45 end to the port labeled "RS232" on the BDS-Pro
3. Connect the USB port to the computer
4. Power on the BDS-Pro

5. Check that the adapter shows up properly under the device manager in Windows and take note of the COM port shown

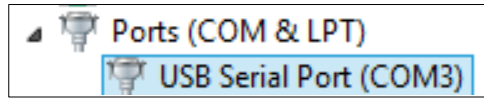

(3) Configure BDS-Pro using Serial Com

1. Launch BDS-Pro Serial Com, ensure the port is correct and the baud rate is 19200
2. The program has three main areas of functionality:
 - A. Displays string and jar measurement data and information
 - B. Used to Start or Stop measurement cycles
 - C. Used to check and configure all parameters

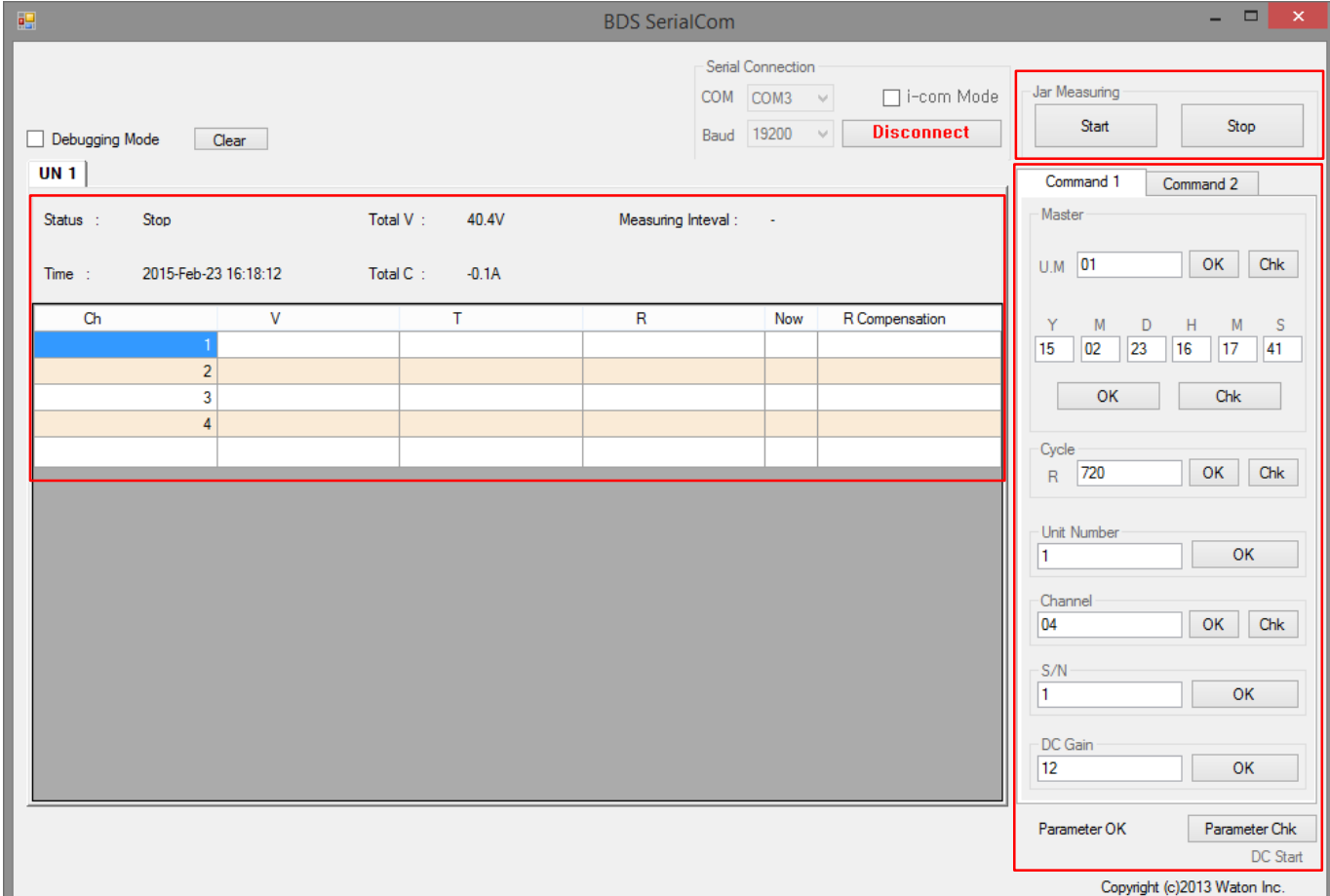

A.

Ch	V	T	R	Now	R Compensation
1					
2					
3					
4					

B.

C.

Copyright (c)2013 Waton Inc.

3. Set Basic Parameters on the BDS:

- A. **U.M:** Sets to the number of master units, always set to “01” for the BDS-Pro.
- B. **YY-MM-DD-HH-MM-SS:** Set the date & time
- C. **Cycle:** Set the measurement cycle in minutes
- D. **Unit Number:** Set the unit number, will always be “1” for the BDS-Pro.
- E. **Channel:** Set the channel number, this is equal to the number of jars being monitored
- F. **S/N:** Set the serial number (optional)
- G. **DC Gain:** Set the DC Gain, refer to the table below

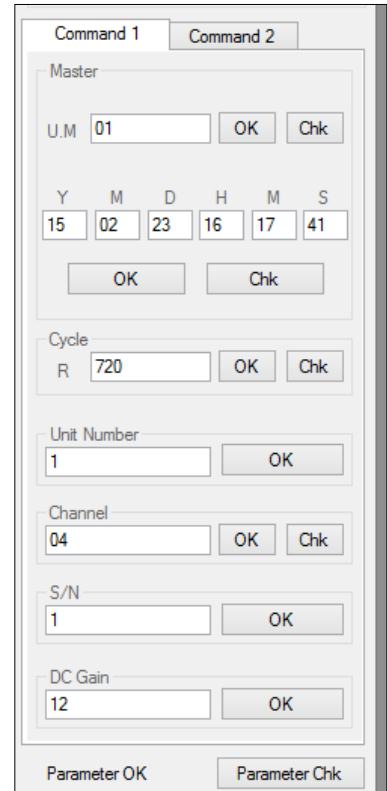

The screenshot shows the configuration interface for Command 1. The parameters are as follows:

- Master:** U.M: 01
- Date & Time:** Y: 15, M: 02, D: 23, H: 16, M: 17, S: 41
- Cycle:** R: 720
- Unit Number:** 1
- Channel:** 04
- S/N:** 1
- DC Gain:** 12

The DC Gain value needs to be programmed correctly based on the CT rating for the system. First check the rating on the CT clamp as shown below in red:



Then enter the value in BDS-Pro Serial Com based on the chart below.

DC-CT Gain Chart					
DC CT	100A	200A	300A	400A	500A
Gain Value	11	12	13	14	15
DC CT	600A	700A	800A	900A	1000A
Gain Value	16	17	18	19	20

NOTE: Battery parameters vary based on battery type and recommendation from the manufacture. If in doubt contact the battery manufacturer for alarm recommendations.

4. Set String Alarm Parameters

Select the Command 2 tab

- A. **Over V:** Set the over string voltage value
- B. **Under V:** Set the under string voltage value
- C. **Over C:** Set the over current value
- D. **Under C:** Set the under current value

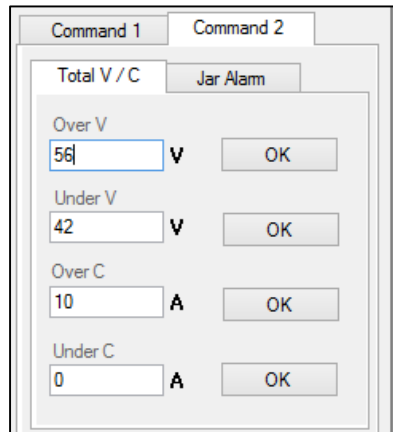

5. Set Jar Alarm Parameters

Select the Jar Alarm sub-tab

- A. **Warning:** Set the jar resistance warning value in milliohms
- B. **Fail:** Set the jar resistance fail value in milliohms
- C. **Over V:** Set the jar over voltage value
- D. **Under V:** Set the jar under voltage value
- E. **Temp:** Set the jar temperature alarm value

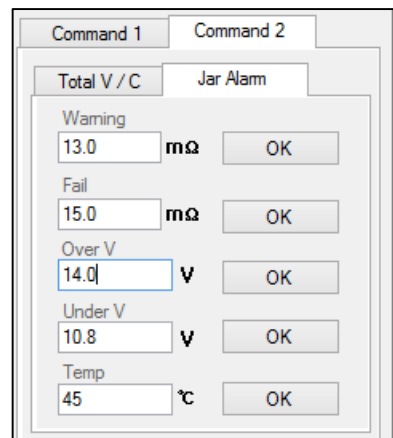

6. Start Measurement

Start measurement to view measured data and ensure the BDS is working properly.

- A. Click the Start button, the BDS should start making a clicking sound for every jar measured, after each click the measured values should populate as shown below
- B. When the measurement cycle is complete, the **Status** will change to *Wait*
- C. Check that the values look correct, verify with a multi-meter if necessary

Status :	Wait	Total V :	50.5V	Measuring Interval :	720
Time :	2015-Feb-23 16:20:22	Total C :	-0.1A		
Ch	V	T	R	Now	R Compensation
1	12.21	61	6.069		
2	12.63	62	6.275		
3	12.65	62	6.097		
4	12.96	63	6.356	*	

7. Set Jar Resistance Compensation

Some jars might display a higher resistance if they are connected to a jumper (such as between racks or splits in the bank). This can be corrected using the **R Compensation** feature.

A. Determine the compensation value

NOTE: Internal resistance measurements are not an exact measurement. The I.R. value can vary slightly for each jar each time it is tested. It is important to first establish a baseline I.R. value before calculating the compensation factor.

B. Enter the Channel Number **Ch** for the value which needs to be changed

C. Enter the compensation **Value** in milliohms

D. For each jar entered, the measured resistance value will be subtracted by the entered compensation value

R Compensation		
Ch	<input type="text" value="03"/>	<input type="button" value="OK"/>
Value	<input type="text" value="3.50"/>	<input type="button" value="Chk"/>

8. Network Communication Setup

The BDS-Pro Battery Monitoring System comes standard with Centroid 2 battery management software. This software is used to manage all of the battery monitoring systems on the network. Alternatively, the BDS-Pro can be ordered with Modbus protocol for communication to a third party BMS or SCADA system.

NOTE: The BDS-Pro is shipped to communicate either TCP/IP with Centroid 2 or TCP/IP Modbus. The unit can only communicate via the protocol it was configured to work with, not both.

8.1 Configure MPU IP Address

Parts:	BDS-Pro Installed, Ethernet Cable, Laptop Computer with WIZ100SR Config Tool
Tools:	IBwatch Installation Document, Laptop Computer with WIZ100SR Config Tool

Refer to the steps below to configure the BDS-Pro.

1. Connect the computer (with the WIZ100SR tool installed) directly to the Ethernet port on the BDS-Pro using an Ethernet or Crossover cable and power on the BDS-Pro
2. On the computer, open "WIZ1x0SR_105SR_CFG.exe"
3. Click the "Search" button and the MAC address of the BDS should appear
4. Edit only the fields listed below and outlined in red
5. **Board List:** The MAC address of the BDS-Pro will appear on the left column "Board List". Record the MAC address under the MAC Address column in the IBwatch Installation Document

6. **Local IP:** The Local IP field represents the IP of the BDS-Pro. Edit only the last quartet of the IP address. Record the set IP under the IP Address column of the IBwatch Installation Doc
7. **Gateway:** Enter the network/router IP in this field
8. **Server IP:** Enter the IP address of the Server PC in this field, this is the computer that Centroid Snet is installed on. (Note, this field can be modified later if the Server IP is not yet determined)
9. Make sure the port is set to 4917
10. Make sure IP Configuration Method is set to “Static” and that Operation Mode is set to “Client”
11. Click “Setting” to save all changes

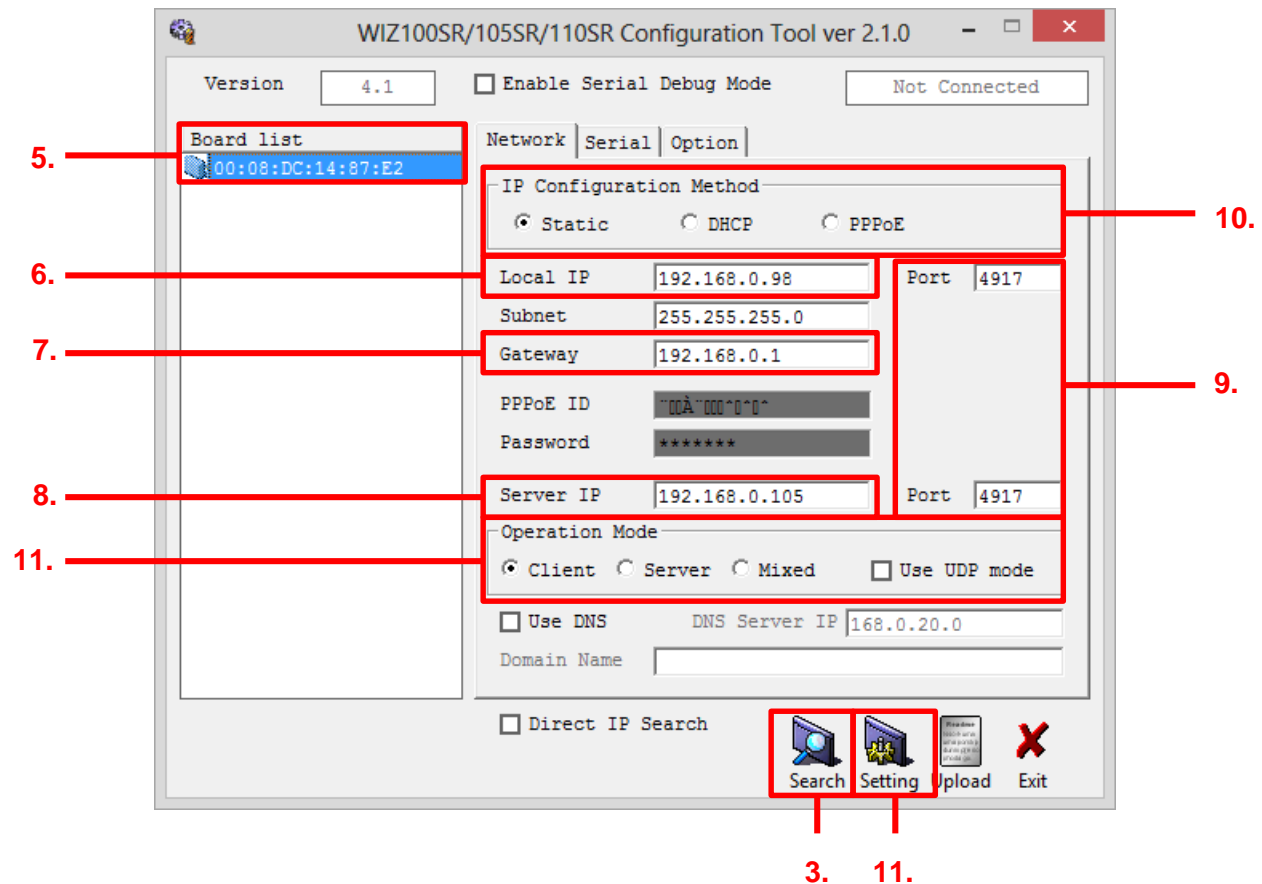



8.2 Connect BDS-Pro to Network

Parts:	BDS-Pro Installed, Ethernet Cable
Tools:	N/A

With the BDS-Pro installed and the IP configured, it can be connected to the company network.

1. Run the Ethernet directly into the TCP/IP port on the side of the BDS-Pro
2. Check that both lights (green & orange) are blinking

9. Sample Connection Diagrams:

The following diagrams are examples of typical BDS-Pro applications.

48V System – (4) 12V Jars

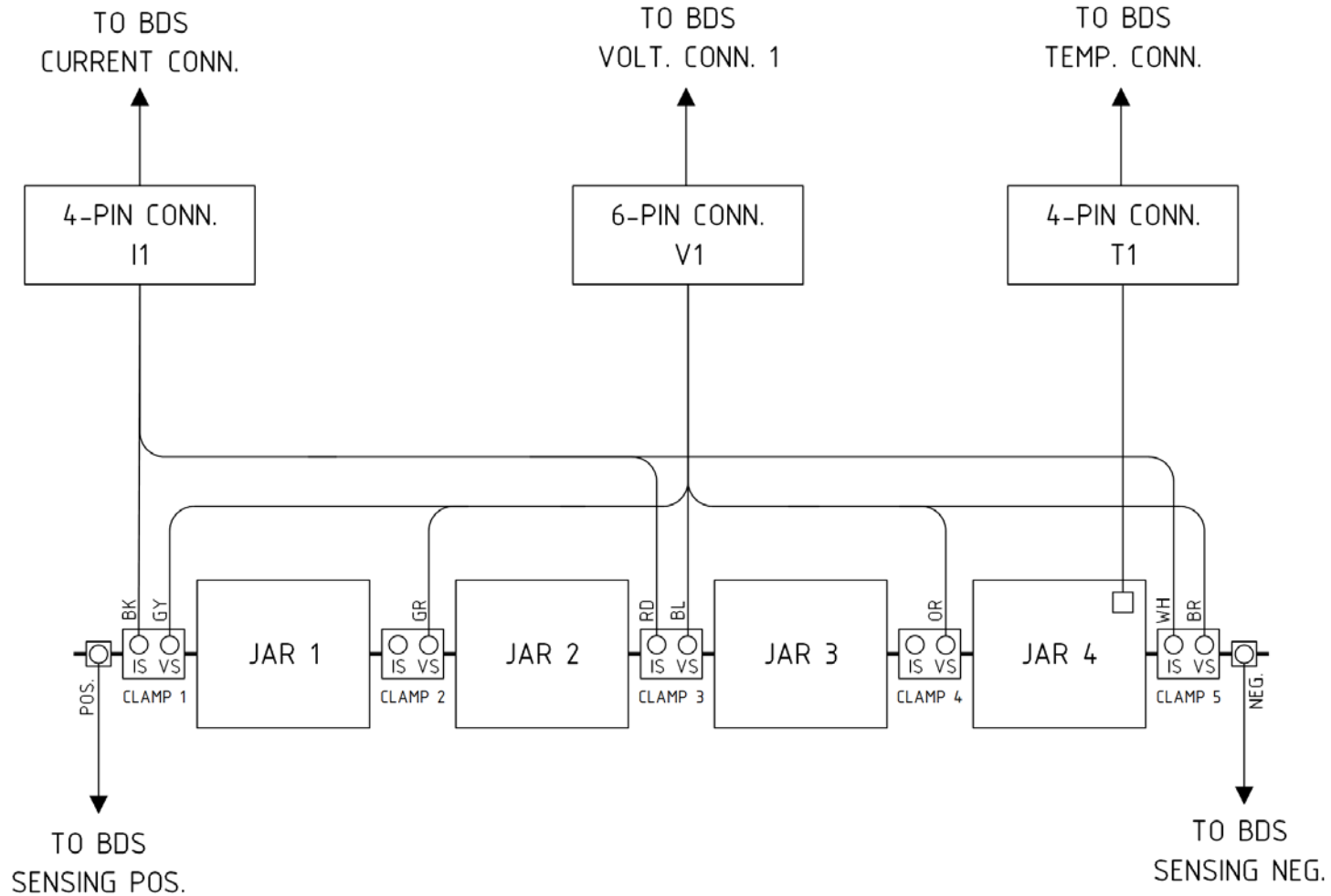

48V System - (6) 8V Jars

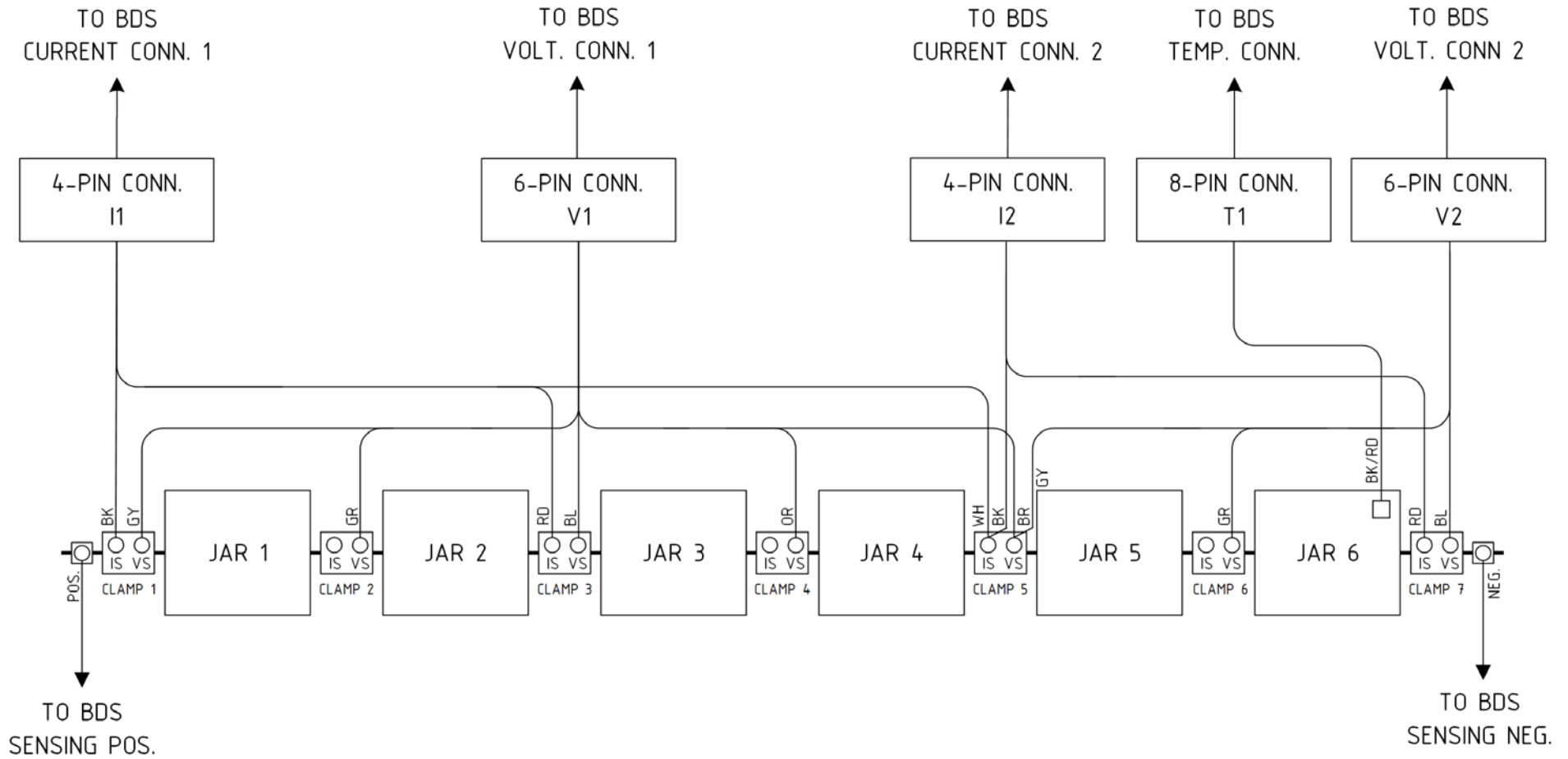

48V System - (8) 6V Jars

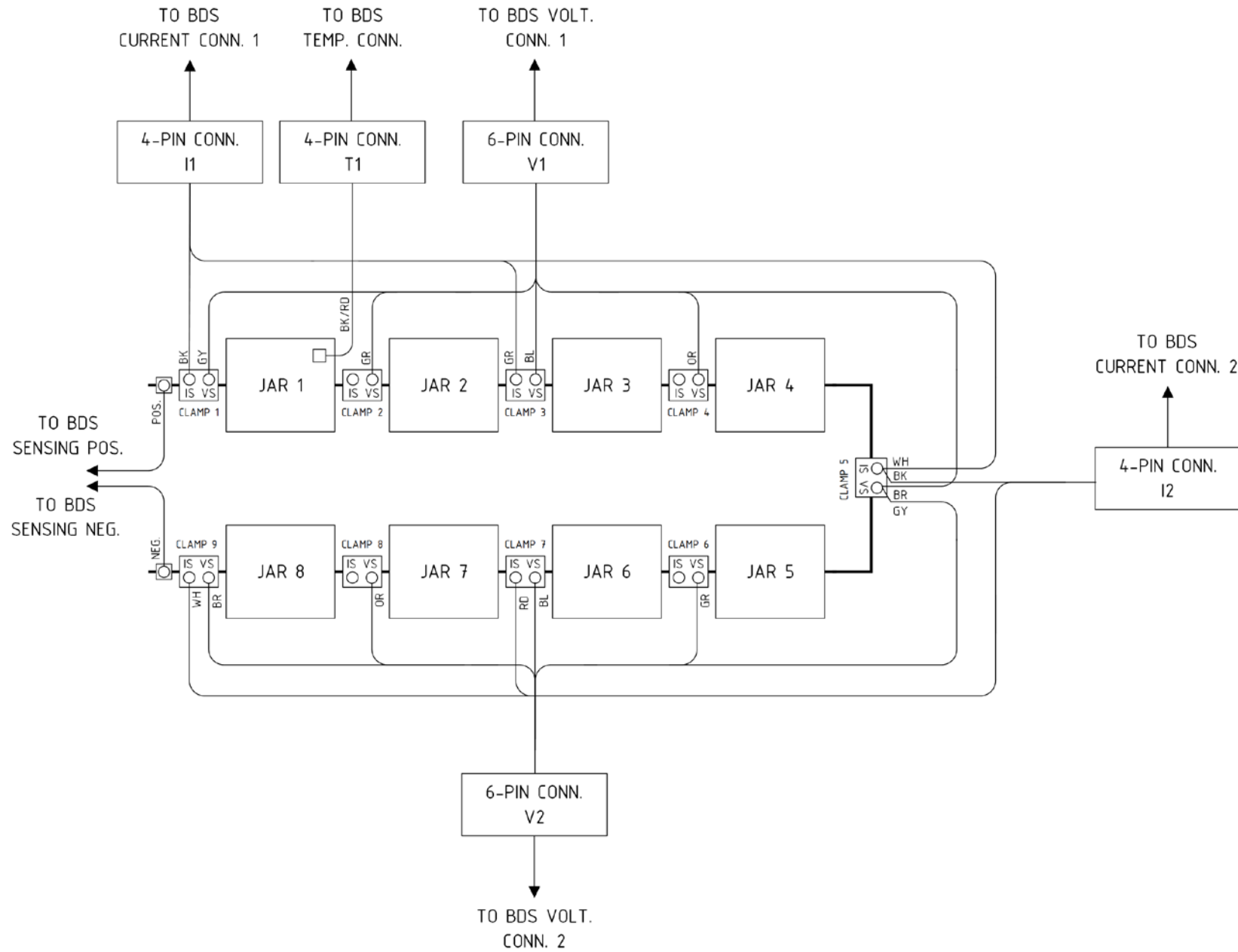

125V System – (10) 12V Jars

