

# AcuPRE™ PM Series

Panel Mount Differential Pressure Sensor  
Installation Guide



1.888.610.7664



[www.calcert.com](http://www.calcert.com)

**ACCUENERGY**

[sales@calcert.com](mailto:sales@calcert.com)

Copyright © 2025 V: 1.0.1



All Accuenergy brands and trademarks in this document are the property of Accuenergy Inc. All other brands and trademarks may be the property of the respective owners of these rights.

This instruction may not be altered, copied or reproduced in whole or in part by any means without the expressed written consent of Accuenergy.

Please read this manual carefully before installation, operation, and maintenance of the AcuPRE PM Panel Mount Differential Pressure Sensor.

The information contained in this document is believed to be accurate at the time of publication, however, Accuenergy assumes no responsibility for any errors which may appear here and reserves the right to make changes without prior notice as part of continuing improvements. Please ask the local representative for the latest product specifications before ordering.

The following symbols in this manual appear throughout this documentation, in addition to the electrical warning of danger or safety risk during the installation and operation of the sensors.

	<p><b>Electrical Shock Hazard:</b> Contains information about procedures which must be followed to prevent the risk of electric shock and danger that can result in personal injury or death.</p>
	<p><b>Safety Warning:</b> Contains information about circumstances which, if not considered, may result in personal injury or death.</p>
<p><b>NOTE</b></p>	<p><b>NOTE:</b> An advance notice to provide additional information before an action is taken by the user.</p>
<p><b>ALERT</b></p>	<p><b>ALERT:</b> Indicating the operation may lead to device malfunction or potential data loss.</p>

Installation and maintenance of the AcuPRE PM Differential Pressure Sensor shall only be performed by qualified, competent professionals who have received training and have experience with high voltage and current devices.

Accuenergy shall not be responsible or liable for any damage caused by improper sensor installation and/or operation.

# Table of Contents

<b>Introduction.....</b>	<b>5</b>
Overview .....	5
Dimensions.....	5
<b>Installation .....</b>	<b>6</b>
Step 1: Preparations .....	6
Step 2: Pressure Tip Mounting Locations for Common Applications.....	7
Duct Static Pressure Monitoring .....	7
Filter Status Monitoring .....	7
Controlling Room Pressure .....	8
Step 3: Prepare PVC Tubing .....	8
Step 4: Mounting the Sensor .....	9
Step 5: Electrical Wiring.....	9
Step 6: Selecting Response Rate .....	11
Step 7: Zero Reset and Calibration .....	12
<b>Technical Specifications .....</b>	<b>13</b>



# Introduction

## Overview

The AcuPRE PM differential pressure sensor features a compact design and DIN rail mount support, making it an ideal fit for panel builds used in OEM applications. The DP sensor utilizes advanced MEMS technology and digital processing for  $\pm 1.00$  full-scale accuracy, delivering the most reliable real-time pressure data.

The DP sensor offers user-configurable response time and easy zero calibration, enabling the ultimate flexibility to meet diverse monitoring needs. The sensor provides an analog output proportional to the measured difference in pressure and the selected pressure range. It can be used to monitor pressure in any application that has non-combustible and non-corrosive air.

The AcuPRE PM series features various base model numbers with different analog output options, including 0-5 VDC or 4-20 mA, with either unidirectional (up to 0 to 40 inWC) or bidirectional (up to -5.0 to 5.0 inWC) pressure range, depending on the model selection. The slim form factor and various output options make it a versatile solution for easy installation in panel builds that require precise pressure control.

**ALERT:** When using 24VAC to power the AcuPRE PM, it is strongly recommended to power the unit with an independent, dedicated, UL-listed class 2 transformer.

**ALERT:** If any DIP switch or jumper settings are changed, make sure to power off the unit first prior to making changes. Set the DIP switches to the correct position, then reapply power.

## Dimensions

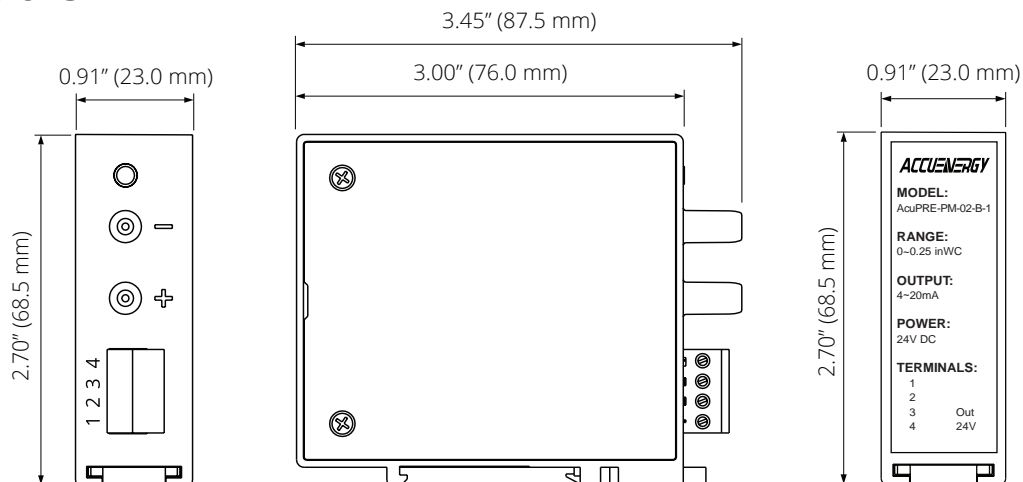

Figure 1 AcuPRE PM Front and Side Views

# Installation

## Step 1: Preparations

Make sure to prepare all necessary components and accessories before installing the AcuPRE PM sensor. Different accessories may be required depending on the application.

**Table 1 Required Components and Accessories for AcuPRE PM**

Items	Description	Type
AcuPRE PM Series	Panel Mount Differential Pressure Sensor	Sensor
PVC Tubing	Clear PVC tubing. Available in two different sizes.	Accessories*
Pressure Tip	Six different pressure tip models, available in ABS plastic or 304 stainless steel in various lengths and shapes.	Accessories*
Pickup Ports	Two models available.	Accessories*

\* Accessories are sold separately.

The following diagram shows the internal schematics of the AcuPRE PM differential pressure sensor. The output ports, measurement unit selection DIP switches, response rate selection DIP switches, and pressure range selection jumpers are highlighted.

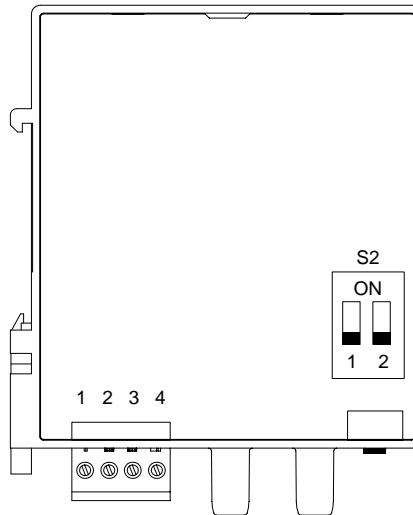

Figure 2 Internal Schematics of AcuPRE PM

## Step 2: Pressure Tip Mounting Locations for Common Applications

### Duct Static Pressure Monitoring

The AcuPRE PM requires one static pressure tip for duct static pressure monitoring.

Accuenergy offers static pressure tip models AcuPRE-XX-003, AcuPRE-XX-005, AcuPRE-XX-006, AcuPRE-XX-007, and AcuPRE-XX-008 for duct static pressure monitoring. Available in ABS plastic or 304 stainless steel in various lengths and shapes. Refer to the [AcuPRE PM datasheet](#) for full description.

When placing the AcuPRE PM DP sensor, the pressure ports and the static pressure tip should not be in close proximity to the bends, fans, or dampers to avoid turbulent air. The tapping point must not be located where it will be affected by obstructions to the flow.

The HIGH-pressure port of the PM will be connected to the duct static pressure tip. The LOW-pressure port will monitor ambient pressure.

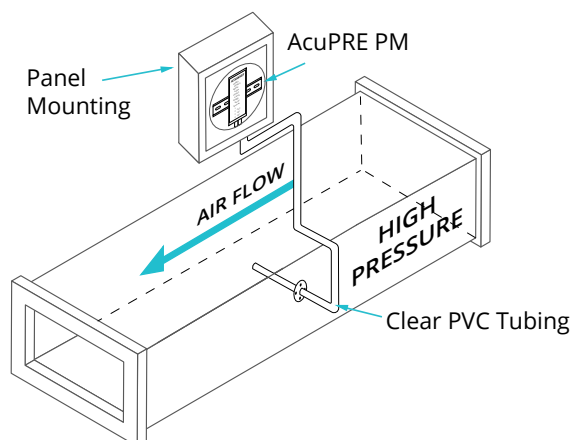

Figure 3 AcuPRE PM Duct Static Pressure Connection

### Filter Status Monitoring

The AcuPRE PM requires two static pressure tips for filter status monitoring.

Accuenergy offers static pressure tip models AcuPRE-XX-003, AcuPRE-XX-005, AcuPRE-XX-006, AcuPRE-XX-007, and AcuPRE-XX-008. Available in ABS plastic or 304 stainless steel in various lengths and shapes. Refer to the [AcuPRE PM datasheet](#) for full description.

When the filter is clean and not obstructed by any debris, the pressure difference (differential pressure) is low. As the filter clogs with dust and debris, the pressure drop across the filter increases and the differential pressure increases.

The HIGH-pressure port will be mounted in front of the filter and the LOW-pressure port should be installed after the filter. Refer to the following figure.

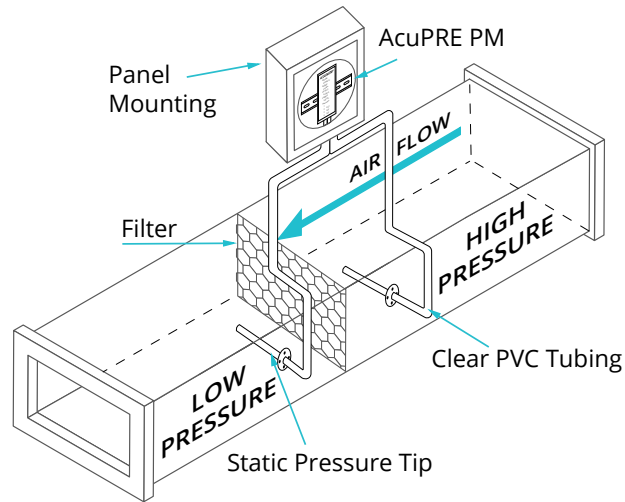

**Figure 4 AcuPRE WM Filter Status Detection**

### Controlling Room Pressure

Utilize the AcuPRE-XX-009 room or AcuPRE-XX-010 pressure pickup port for space or room pressure reference. Refer to the AcuPRE PM datasheet for additional details.

When attempting to maintain positive pressure in the room, connect the HIGH-pressure port to the pickup port reference in the space requiring positive pressure. The LOW-pressure port should be connected outside of the space in the common hallway.

In a negative room pressure application, the LOW-pressure port would be connected to the pickup port mounted in the room, and the HIGH-pressure port would reference pressure outside of the room.

### Step 3: Prepare PVC Tubing

The AcuPRE PM accepts 3/16" (5mm) inner diameter (ID) tubing on both the High/Low pressure ports. Simply cut the PVC tubing into the desired length and push onto the port connections.

The HIGH-pressure and LOW-pressure ports of the AcuPRE PM require a 3/16" (5mm) ID PVC tubing for the process connection. Accuenergy recommends sourcing accessory AcuPRE-XX-001 or AcuPRE-XX-002 clear PVC tubing.

For best results, 3/16" (5mm) ID tubing lengths should be limited to a maximum length of 50' (15.24m). Larger ID tubing may be required for runs longer than 50'.

Inspect tubing after installation to ensure no kinks or punctures are present, which will affect pressure accuracy.

#### Step 4: Mounting the Sensor

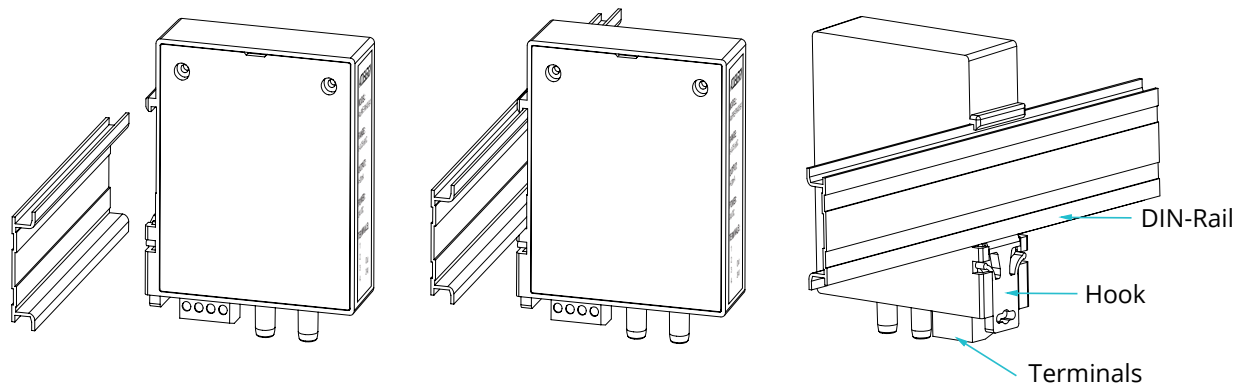

Figure 5 AcuPRE PM DIN Rail Mounting

Install the AcuPRE PM sensor on standard 35mm DIN rail. The DP sensor should be installed so that the pressure ports are pointing downwards vertically, as shown in the figure above. Insert the DP sensor's upper hook into the DIN rail, then buckle the lower white plastic hook into the DIN rail as shown above. The plastic hook can be pulled down to assist with the mounting process.

**NOTE:** Avoid mounting the AcuPRE PM in close proximity to vibrating equipment or surfaces. Excessive vibration may cause issues with pressure readings.

#### Step 5: Electrical Wiring



The DP sensor must be powered OFF during installation and wiring. Failure to do so may result in damage to the DP sensor.

Unplug the wiring terminal block of the AcuPRE PM, as shown below.

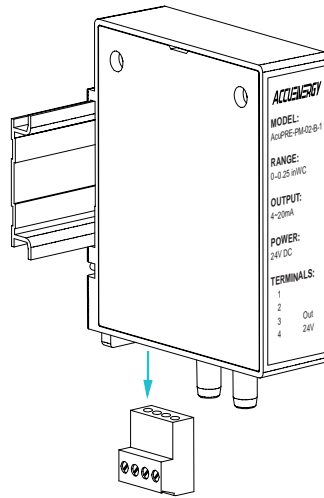

Figure 6 AcuPRE PM Remove Terminal Block

**ALERT:** When using 24VAC to power the AcuPRE PM, it is strongly recommended to power the unit with an independent dedicated UL-Listed class 2 transformer.

**ALERT:** If sharing a 24VAC transformer with other equipment such as controllers, transmitters or actuators, improper polarity will cause damage to the sensor.

**ALERT:** Do not mix half and full-wave rectified devices when powering with AC voltage. The AcuPRE WM is half-wave rectified.

Locate the wiring terminals and connect the AcuPRE PM DP sensor as shown in the following figure. AcuPRE PM series is available in 0-10V or 4-20mA output ratings, depending on the model selection.

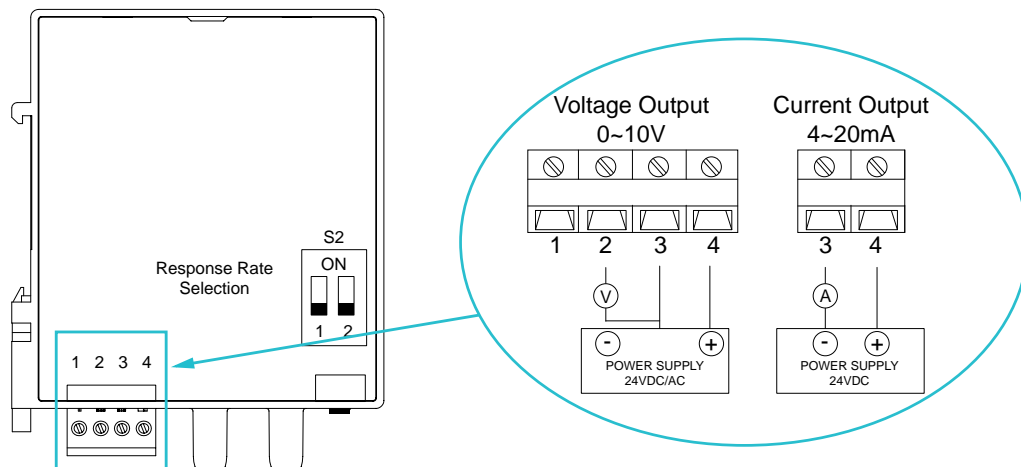

Figure 7 AcuPRE PM Wiring Terminals

Different models have different electrical wiring terminals based on the selected analog output. Wire the sensor according to the wiring diagram on the front cover. See the figure above.

After the power supply, ground terminal (if applicable), and signal output wiring are connected, reinsert the wiring terminal block back into the AcuPRE PM DP sensor. The wiring terminal block must be inserted all the way for proper connection.

**Table 2 AcuPRE PM Wiring Terminals**

AcuPRE PM Wiring Termination			
Analog Output Signal	24V Power Terminal	GND Terminal	OUT Terminal
4 to 20 mA (2-Wire)	18.5~35VDC	Not Applicable for This Model	Milliamp Signal To Controller Analog Input
0 to 10 VDC (3-Wire)	16~28VAC/ 16~35VDC	To Controller Ground	VDC Signal To Controller Analog Input

**NOTE:** Accuenergy recommends 16 to 24 AWG twisted pair wires or shielded cables for all DP sensors. This applies to both supply power and analog output wiring.

**ALERT:** When using a shielded cable, ground the shield only at the controller end. Grounding both ends can cause a ground loop.

**NOTE:** Not observing these recommendations may damage the product and void the warranty.

### Step 6: Selecting Response Rate

The DP sensor has field-selectable response times of 0.5 (Default), 1, 2, and 5 seconds. Remove the cover for the AcuPRE PM sensor to locate the response rate selection DIP switches. Refer to the following figure for DIP switch location and settings.

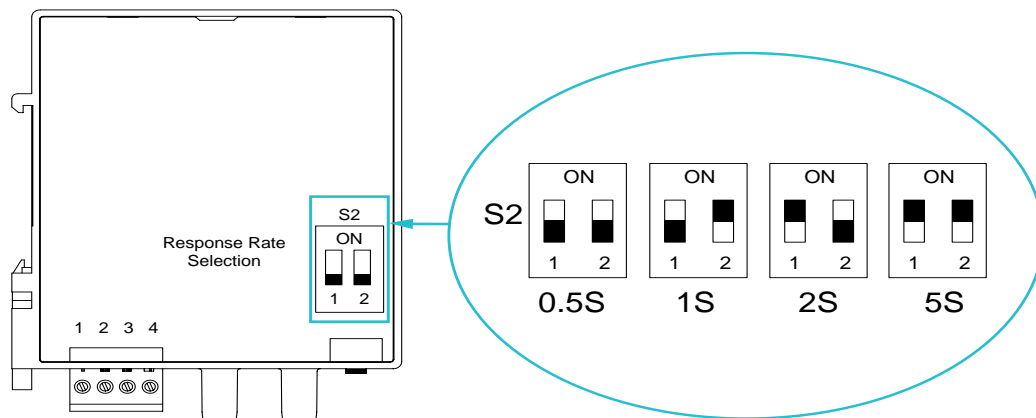

Figure 8 AcuPRE PM Response Time Selection DIP Switches

### Step 7: Zero Reset and Calibration

Performing a zero reset calibration after the AcuPRE PM is installed is recommended.

Different environments, shipping, and DP sensor characteristics may cause a sensor drift. Perform the initial zero reset with power applied. Wait 15 to 20 minutes to allow the circuitry to initialize and stabilize before performing the zero reset calibration.

During the zero reset calibration, keep the HIGH (+) and LOW (-) pressure ports unconnected from the PVC tube in stable air. The zero reset process must be performed with NO pressure applied to the sensor.

Press the **ZERO** button for 5 seconds to perform the reset, release the button and monitor the analog output until it stabilizes.

The DP sensor should be periodically reset to zero every 6 to 12 months to offset any drifting that may have occurred.

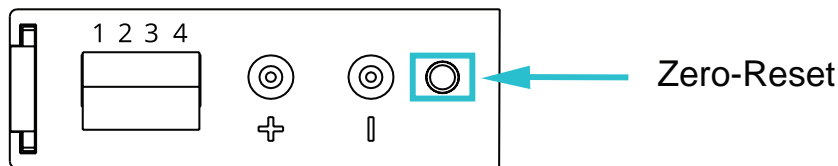

Figure 9 AcuPRE PM Zero Calibration Button

# Technical Specifications

## Electrical

Voltage Power	16~28VAC / 16~35VDC
Current Power	18.5~35VDC (RL=500Ω), 8.5~35VDC (RL=0Ω)
Output (Based on Select Models)	0~10VDC, 4~20mA (2 Wires)
Output Load	≤500Ω (Current), ≥2kΩ (Voltage)

## Environmental

Medium	Non-Combustible, Non-Corrosive Air
Medium Temperature Range	0 to 60°C (32 to 140°F)
Operating Temperature Range	-20 to 70°C (-4 to 158°F)
Temperature Compensation	0 to 50°C (32 to 122°F)
Working Pressure	Overload 10xFS, Burst 15xFS

## Mechanical

Mounting	35mm DIN Rail
Connection	5mm ID Tubing (0.19") High/Low Pressure Ports
Weight	110g (0.24 lbs)

## Performance

Accuracy	±1.0% FS
Stability	±0.5% FS/Year
Thermal Effect % FS/°C (Zero/FS)	±0.05/0.08
Response Time	0.5/1/2/5s, Can be Set by DIP Switches

## Certification/Warranty

Enclosure Material	Fire-Proof ABS+PC, Fire Retardant UL94V-0
Protection	IP30
Agency Approvals	CE
Warranty	5 Years

# ACCUEENERGY

MAKE ENERGY USAGE SMARTER

For additional help please reach out to:

**Accuenergy Sales**

**Accuenergy Technical Support**



ISO 9001, 14001  
& 45001 Certified



Revision Date: November 2025 Version: 1.0.1  
Specs Subject To Change Without Notice.