

FLUKE®

Calibration

9102S
Dry-Well Calibrator
Users Guide

9102S__ugeng0000

Limited Warranty & Limitation of Liability

Each product from Fluke Corporation ("Fluke") is warranted to be free from defects in material and workmanship under normal use and service. The warranty period is one year for Dry-Well Calibrators. The warranty period begins on the date of the shipment. Parts, product repairs, and services are warranted for 90 days. The warranty extends only to the original buyer or end-user customer of a Fluke authorized reseller, and does not apply to fuses, disposable batteries or to any other product, which in Fluke's opinion, has been misused, altered, neglected, or damaged by accident or abnormal conditions of operation or handling. Fluke warrants that software will operate substantially in accordance with its functional specifications for 90 days and that it has been properly recorded on non-defective media. Fluke does not warrant that software will be error free or operate without interruption. Fluke does not warrant calibrations on the Field Metrology Well.

Fluke authorized resellers shall extend this warranty on new and unused products to end-user customers only but have no authority to extend a greater or different warranty on behalf of Fluke. Warranty support is available if product is purchased through a Fluke authorized sales outlet or Buyer has paid the applicable international price. Fluke reserves the right to invoice Buyer for importation costs of repairs/replacement parts when product purchased in one country is submitted for repair in another country.

Fluke's warranty obligation is limited, at Fluke's option, to refund of the purchase price, free of charge repair, or replacement of a defective product which is returned to a Fluke authorized service center within the warranty period.

To obtain warranty service, contact your nearest Fluke authorized service center or send the product, with a description of the difficulty, postage, and insurance prepaid (FOB Destination), to the nearest Fluke authorized service center. Fluke assumes no risk for damage in transit. Following warranty repair, the product will be returned to Buyer, transportation prepaid (FOB Destination). If Fluke determines that the failure was caused by misuse, alteration, accident or abnormal condition or operation or handling, Fluke will provide an estimate or repair costs and obtain authorization before commencing the work. Following repair, the product will be returned to the Buyer transportation prepaid and the Buyer will be billed for the repair and return transportation charges (FOB Shipping Point).

THIS WARRANTY IS BUYER'S SOLE AND EXCLUSIVE REMEDY AND IS IN LIEU OF ALL OTHER WARRANTIES, EXPRESS OR IMPLIED, INCLUDING BUT NOT LIMITED TO ANY IMPLIED WARRANTY OF MERCHANTABILITY OR FITNESS FOR A PARTICULAR PURPOSE. FLUKE SHALL NOT BE LIABLE FOR ANY SPECIAL, INDIRECT, INCIDENTAL, OR CONSEQUENTIAL DAMAGES OR LOSSES, INCLUDING LOSS OF DATA, WHETHER ARISING FROM BREACH OF WARRANTY OR BASED ON CONTRACT, TORT, RELIANCE OR ANY OTHER THEORY.

Since some countries or states do not allow limitation of the term of an implied warranty, or exclusion or limitation of incidental or consequential damages, the limitations and exclusions of this warranty may not apply to every buyer. If any provision of this Warranty is held invalid or unenforceable by a court of competent jurisdiction, such holding will not affect the validity or enforceability of any other provision.

Specifications subject to change without notice. • Copyright © 2005 • Printed in USA

Table of Contents

1	Before You Start	1
1.1	Introduction.....	1
1.2	Symbols	2
1.3	Safety Information.....	3
1.3.1	⚠ WARNINGS	3
1.3.2	⚠ CAUTIONS	5
1.4	Authorized Service Centers.....	6
2	Specifications and Environmental Conditions.....	9
2.1	Specifications	9
2.2	Environmental Conditions	9
3	Quick Start.....	11
3.1	Unpacking	11
3.2	Set-up	11
3.3	AC Power Operation.....	11
3.4	DC Power Operation.....	12
3.5	Setting the Temperature.....	12
4	Parts and Controls.....	13
4.1	Rear Panel	13
4.2	Front Panel.....	14
4.3	Accessories	15
5	General Operation.....	17
5.1	Setting the Temperature.....	17
5.2	Changing Display Units.....	17
6	Controller Operation.....	19
6.1	Well Temperature	19
6.2	Temperature Set-point	19
6.2.1	Programmable Set-points	19
6.2.2	Set-point Value	21
6.2.3	Temperature Scale Units.....	21
6.3	Scan.....	22

9102S Dry-Well Calibrator

6.3.1	Scan Control.....	22
6.3.2	Scan Rate.....	22
6.4	Set-point Resistance.....	22
6.5	Secondary Menu.....	23
6.6	Heater Power	23
6.7	Proportional Band	24
6.8	Controller Configuration.....	25
6.9	Operating Parameters	25
6.10	High Limit.....	25
6.11	Serial Interface Parameters	25
6.11.1	Baud Rate	26
6.11.2	Sample Period.....	26
6.11.3	Duplex Mode.....	26
6.11.4	Linefeed	27
6.12	Calibration Parameters	27
6.12.1	R0.....	28
6.12.2	ALPHA.....	28
6.12.3	DELTA.....	29
7	Digital Communication Interface.....	31
7.1	RS-232 Connection.....	31
7.2	Interface Commands	32
8	Test Probe Calibration	35
8.1	Calibrating a Single Probe.....	35
8.2	Dry-well Characteristics.....	35
8.2.1	Stabilization and Accuracy	35
9	Calibration Procedure.....	37
9.1	Calibration Points.....	37
9.2	Calibration Procedure	37
9.2.1	Compute DELTA	37
9.2.2	Compute R0 and ALPHA	38
9.2.3	Accuracy and Repeatability.....	39
10	Maintenance	41
11	Troubleshooting.....	43

11.1 Troubleshooting Problems, Possible Causes, and Solutions.....	43
11.2 CE Comments.....	44
11.2.1 EMC Directive	44
11.2.2 Low Voltage Directive (Safety)	44

Tables

Table 1 International Electrical Symbols used on products.....	2
Table 2 Specifications.....	9
Table 3 Accessories.....	15
Table 4 Controller communications commands	32



Figures

Figure 1 12 V DC Power Source Polarity 12

Figure 2 Back Panel..... 13

Figure 3 Front Panel..... 14

Figure 4 Controller operation flowchart 20

Figure 5 Serial Cable Wiring 31

1 Before You Start

1.1 Introduction

The Fluke Calibration 9102S Mid-Range Field Calibrator is a small portable instrument designed for quick on-site checks and calibration of thermocouple and RTD temperature probes. This instrument is small enough to use in the field, and accurate enough to use in the lab. Calibrations may be done over a range of -10°C to 122°C (14°F to 252°F). Temperature display and setpoint resolution are 0.1 degrees.

The instrument features:

- A controlled temperature block with two calibration insert sleeves
- Rapid heating and cooling
- Prop stand
- Handle strap
- RS-232 interface capability
- +12 Volt DC battery option

Built in programmable features include:

- Temperature scan rate control
- Eight set-point memory
- Adjustable readout in $^{\circ}\text{C}$ or $^{\circ}\text{F}$

The temperature is accurately controlled by Fluke's digital controller. The controller uses a precision platinum RTD as a sensor and controls the well temperature with transistor driven thermoelectric devices.

The LED front panel shows the current well temperature. The temperature may be set, using the control buttons, to any desired temperature within the instrument's range. Multiple fault protection devices insure user and instrument safety and protection.

This dry-well calibrator was designed for portability, low cost, and ease of operation. Through proper use and maintenance, the instrument will provide continued accurate calibration of temperature sensors and devices. The user should be familiar with the safety guidelines and operating procedures of the calibrator as described in the instruction manual.















9102S Dry-Well Calibrator



Symbols

1.2 Symbols

Table 1 lists the International Electrical Symbols. Some or all of these symbols may be used on the instrument or in this manual.

Table 1 International Electrical Symbols used on products

Symbol	Description
	AC (Alternating Current)
	AC-DC
	Battery
	Complies with European Union directives
	DC
	Double Insulated
	Electric Shock
	Fuse
	PE Ground
	Hot Surface (Burn Hazard)
	Read the User's Guide (Important Information)
	Off
	On
	Canadian Standards Association

Symbol	Description
	C-TICK Australian EMC mark
	The European Waste Electrical and Electronic Equipment (WEEE) Directive (2002/96/EC) mark.

1.3 Safety Information

Use this instrument only as specified in this manual. Otherwise, the protection provided by the instrument may be impaired. Refer to the safety information in the Warnings and Cautions sections below.

The following definitions apply to the terms “Warning” and “Caution”.

- “Warning” identifies conditions and actions that may pose hazards to the user.
- “Caution” identifies conditions and actions that may damage the instrument being used.

1.3.1 WARNINGS

To avoid personal injury, follow these guidelines.

GENERAL

- **DO NOT** use this instrument in environments other than those listed in the User’s Guide.
- Inspect the instrument for damage before each use. **DO NOT** use the instrument if it appears damaged or operates abnormally.
- Follow all safety guidelines listed in the user’s manual.
- Calibration Equipment should only be used by Trained Personnel.
- If this equipment is used in a manner not specified by the manufacturer, the protection provided by the equipment may be impaired.
- Before initial use, or after transport, or after storage in humid or semi-humid environments, or anytime the dry-well has not been energized for more than 10 days, the instrument needs to be energized for a “dry-out” period of 2 hours before it can be assumed to meet all of the safety requirements of the IEC 1010-1. If the product is wet or has been in a wet environment, take necessary measures to remove moisture prior to applying power such as storage in a low humidity temperature chamber operating at 50 degree centigrade for 4 hours or more.
- **DO NOT** use this instrument for any application other than calibration work. The instrument was designed for temperature calibration. Any other use of the instrument may cause unknown hazards to the user.
- Completely **unattended operation is not recommended.**

9102S Dry-Well Calibrator

Safety Information

- Overhead clearance is required. **DO NOT** place the instrument under a cabinet or other structure. Always leave enough clearance to allow for safe and easy insertion and removal of probes.
- If the instrument is used in a manner not in accordance with the equipment design, the operation of the dry-well may be impaired or safety hazards may arise.
- This instrument is intended for indoor use only.

BURN HAZARDS

- **DO NOT** turn the instrument upside down with the inserts in place; the inserts will fall out.
- **DO NOT** operate near flammable materials.
- Use of this instrument at **HIGH TEMPERATURES** for extended periods of time requires caution.
- **DO NOT** touch the well access surface of the instrument.
- The block vent may be very hot due to the fan blowing across the heater block of the dry-well.
- The temperature of the well access is the same as the actual display temperature, e.g. if the instrument is set to 375°C and the display reads 375°C, the well is at 375°C.
- For top loading dry-wells, the top sheet metal of the dry-well may exhibit extreme temperatures for areas close to the well access.
- The air over the well can reach temperatures greater than 200°C for high temperature (400°C and higher) dry-wells. **Note:** Probes and inserts may be hot and should only be inserted and removed from the instrument when the instrument is set at temperatures less than 50°C. Use extreme care when removing hot inserts.
- **DO NOT** turn off the instrument at temperatures higher than 100°C. This could create a hazardous situation. Select a set-point less than 100°C and allow the instrument to cool before turning it off.
- The high temperatures present in dry-wells designed for operation at 300°C and higher may result in fires and severe burns if safety precautions are not observed.
- A fire may occur if a short circuit occurs along the input cord and no protective devices are on the DC input source. For short circuit protection using a battery, a fuse is required at the battery terminals.
- ELECTRICAL SHOCK
- **DO NOT** operate this instrument without a properly grounded, properly polarized power cord. Electric shock may result.
- **DO NOT** connect this instrument to a non-grounded, non-polarized outlet. Ensure the earth ground to the outlet is properly connected. Electrical shock may result if the outlet is not installed correctly.
- Always replace the power cord with an approved cord of the correct rating and type.

- **HIGH VOLTAGE** is used in the operation of this equipment. **SEVERE INJURY** or **DEATH** may result if personnel fail to observe safety precautions. Before working inside the equipment, turn power off and disconnect power cord.
- If supplied with user accessible fuses, always replace the fuse with one of the same rating, voltage and type.

BATTERY PACK

- To avoid the risk of electric shock or fire, do not use the charger outdoors or in a dusty, dirty, or wet environment.
- If the cord, case, or plug of the charger is damaged in any way, discontinue its use immediately and have it replaced. Never disassemble the charger.
- The battery may contain chemicals that are hazardous. To avoid the risk of exposure to dangerous substances or explosion, immediately discontinue use of the battery if it leaks or becomes damaged. Never allow the battery to be shorted, heated, punctured, dropped, or crushed.
- Store the battery where it will not come into contact with metal or fluids that might short circuit the battery and where it will be safe from excessive temperatures.
- When no longer usable, the battery must be recycled. The battery may be returned to the seller for recycling. Do not dispose of the battery in a landfill.
- Never dispose of the battery in fire as there is danger of explosion which may cause injury or property damage.

1.3.2 ⚠ CAUTIONS

- Always operate this instrument at room temperature between 41°F and 122°F (5°C to 50°C). Allow sufficient air circulation by leaving at least 6 inches (15 cm) of clearance around the instrument.
- Component lifetime can be shortened by continuous high temperature operation.
- **DO NOT** use fluids to clean out the well.
- **Never introduce any foreign material** into the probe hole of the insert. Fluids, etc. can leak into the instrument causing damage.
- **DO NOT** change the values of the calibration constants from the factory set values. The correct setting of these parameters is important to the safety and proper operation of the calibrator.
- **DO NOT** drop the probe sheath in to the well. This type of action can cause a shock to the sensor and affect the calibration.
- The instrument and any thermometer probes used with it are sensitive instruments that can be easily damaged. Always handle these devices with care. **DO NOT** allow them to be dropped, struck, stressed, or overheated.
- The Factory Reset Sequence (see Section , Troubleshooting) should be performed only by authorized personnel if no other action is successful in

9102S Dry-Well Calibrator

Authorized Service Centers

correcting a malfunction. You must have a copy of the most recent Report of Calibration to restore the calibration parameters.

- **DO NOT** operate this instrument in an excessively wet, oily, dusty, or dirty environment. Always keep the well and inserts clean and clear of foreign material.
- The dry-well is a precision instrument. Although it has been designed for optimum durability and trouble free operation, it must be handled with care. Always carry the instrument in an upright position to prevent the probe sleeves from falling out. The convenient handle strap allows for one hand carrying.
- If a mains supply power fluctuation occurs, immediately turn off the instrument. Power bumps from brown-outs could damage the instrument. Wait until the power has stabilized before re-energizing the instrument.
- The prop stand was not designed to be used as a handle for carrying the instrument. To avoid damage, do not force the prop stand beyond the incline positions of the instrument.
- Allow for probe expansion inside the well as the block heats.
- Most probes have handle temperature limits. Be sure that the probe handle temperature limit is not exceeded in the air above the instrument.

1.4 Authorized Service Centers

Please contact one of the following authorized Service Centers to coordinate service on your Fluke product:

When contacting these Service Centers for support, please have the following information available:

- Model Number
- Serial Number
- Voltage
- Complete description of the problem

2 Specifications and Environmental Conditions

2.1 Specifications

Table 2 Specifications

Range	-10°C to 122°C (14°F to 252°F) at an ambient of 23°C
Accuracy	±0.25°C
Stability	±0.05°C
Resolution	0.1°C or °F
Well-to-Well Uniformity	±0.2°C with sensors of similar size at equal depths within wells
Heating Times	ambient to 100°C: 10 minutes
Stabilization	7 minutes
Cooling Times	ambient to 0°C: 10 minutes
Well Depth	4 inches (102 mm)
Removable Inserts	refer to Section , Accessories
Power	94–234 VAC (±10%), 50/60 Hz, 50 W; or 12 VDC
Size	4" H x 6" W x 6.9"D (100 mm x 152 mm x 175 mm)
Weight	4 lb. (1.8 Kg)
Safety	Conforms to EN61010-1 Conforms to CAN/CSA C22.2 No.1010.1 UL3111 and ANSI/ISA-S82.01
Fault Protection	Sensor burnout protection, over-temperature cutout, and electrical fuses
Fuse Rating	250 V, 3 A FF (very fast acting) NO USER SERVICEABLE PARTS

2.2 Environmental Conditions

Although the instrument has been designed for optimum durability and trouble-free operation, it must be handled with care. The instrument should not be operated in an excessively dusty or dirty environment. Maintenance and cleaning recommendations can be found in the Maintenance Section of this manual.

The instrument operates safely under the following conditions:

- temperature range: 5–50°C (41–122°F)
- ambient relative humidity: 15–50%
- pressure: 75kPa–106kPa
- mains voltage within ±10% of nominal
- vibrations in the calibration environment should be minimized
- altitudes less than 2000 meters
- indoor use only

3 Quick Start

3.1 Unpacking

Unpack the dry-well carefully and inspect it for any damage that may have occurred during shipment. If there is shipping damage, notify the carrier immediately.

Verify that the following components are present:

- 9102S Dry-well
- Power Cord
- User's Guide with Report of Calibration
- RS-232 Cable
- 9930 Interface-it Software
- 3102-3 Insert, 3/16"
- 3102-4 Insert, 1/4"
- Insert Removal Tool

3.2 Set-up

Place the calibrator on a flat surface with at least 6 inches of free space around the instrument. Always leave enough clearance in front of the instrument to allow for safe and easy insertion and removal of probes. The prop stand may be swung down to raise the front of the instrument from a horizontal position. Plug the power cord into a grounded mains outlet. Observe that the nominal voltage corresponds to that indicated on the calibrator.

Turn on the power to the calibrator by toggling the power switch on. The fan should begin quietly blowing air through the instrument and the controller display should illuminate after 3 seconds. After a brief self-test the controller should begin normal operation. If the unit fails to operate, check the power connection.

The display should show the well temperature and the well heater will bring the temperature of the well to the set-point temperature.

After using the calibrator, allow the well to cool by setting the temperature to 25°C and waiting 1/2 hour before turning the instrument off.

3.3 AC Power Operation

Plug the dry-well power cord into a mains outlet of the proper voltage, frequency, and current capability. Refer to Section 3.1, Specifications, for the power details. Turn the dry-well on using the switch on the rear panel. The dry-well will turn on and begin to heat to the previously programmed temperature set-point. The front panel LED display will indicate the actual dry-well temperature.

3.4 DC Power Operation

This instrument is equipped with a DC power option. The DC option requires a power source that delivers 12 VDC at 3 amps.



WARNING: A fire may occur if a short circuit occurs along the input cord and no protective devices are on the DC input source. For short circuit protection using a battery, a fuse is required at the battery terminals.

The DC power socket is located on the rear panel of the instrument near the AC power jack. The instrument accepts a 7/32 inch diameter, two-conductor DC power plug such as Switchcraft® PN. 760. Observe the correct polarity as shown in Figure . The outside conductor is positive and the inside is negative. The AC power switch on the rear panel does not switch the DC power.

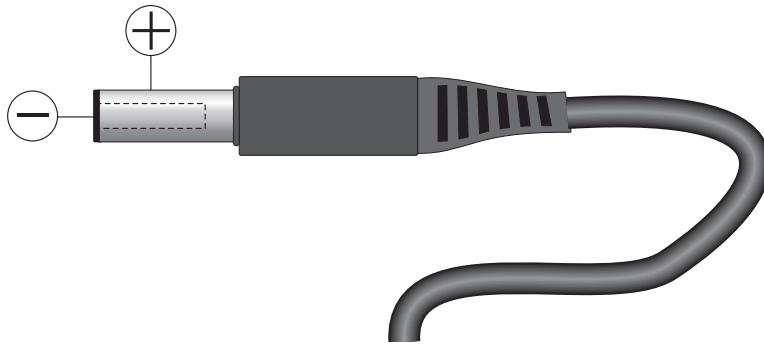

Figure 1 12 V DC Power Source Polarity

The optional Model 9320A Battery Pack, available from Fluke, can be used as a portable power source.

3.5 Setting the Temperature

Section 6.2, Temperature Set-point, on page 19 explains in detail how to set the temperature set-point on the calibrator using the front panel keys. The procedure is summarized here.

1. Press “SET” twice to access the set-point value.
2. Press ▲ or ▼ arrow to change the set-point value.
3. Press “SET” to program in the new set-point.
4. Press and hold “EXIT” to return to the temperature display.

When the set-point temperature is changed the controller switches the well heater on or off to raise or lower the temperature. The displayed well temperature gradually changes until it reaches the set-point temperature. The well may require 5 to 10 minutes to reach the set-point depending on the span. Another 5 to 10 minutes is required to stabilize within $\pm 0.1^{\circ}\text{C}$ of the set-point. Ultimate stability may take 15 to 20 minutes more of stabilization time.

4 Parts and Controls

The user should become familiar with the dry-well calibrator and its parts: (See Figure 2 on this page and Figure 3 on next page).

4.1 Rear Panel

Power Cord - The removable power cord, (Figure) attaches to the back side of the instrument. It plugs into a standard 115 VAC (optional 230 VAC) grounded socket.

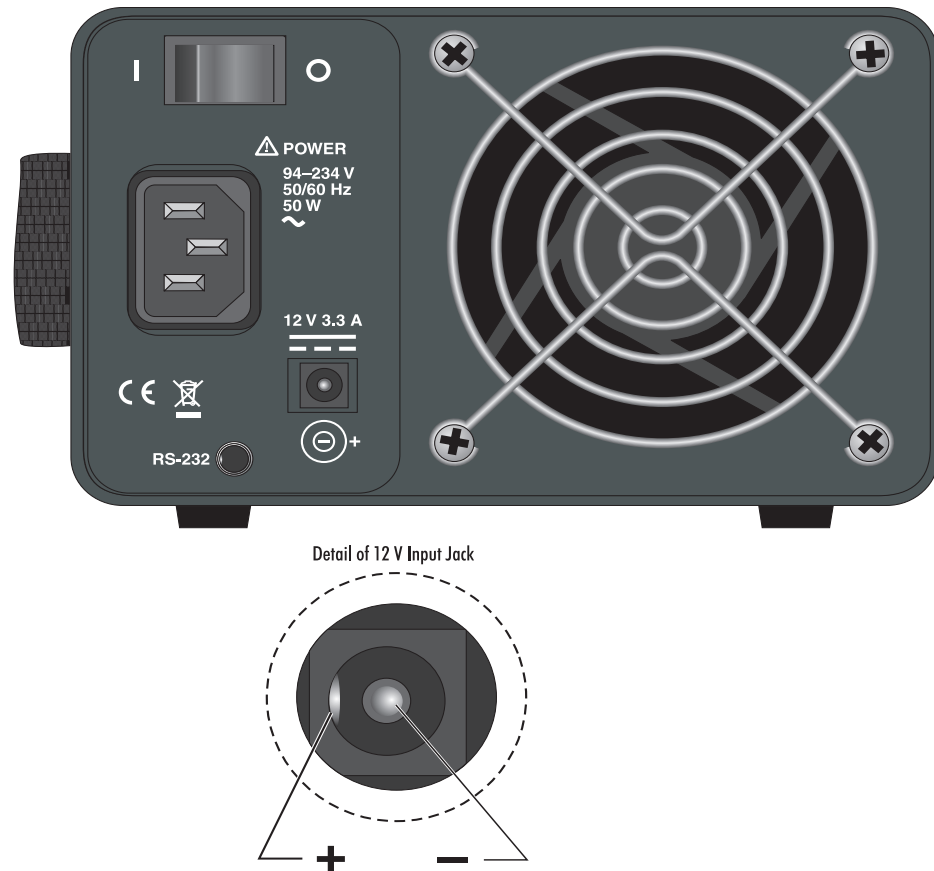

Figure 2 Back Panel

DC Power Jack - The calibrator can be used with a DC power source. The DC input jack requires 12V and 3.3 amps. See Figure and the inset of Figure for pinout.

Power Switch - The power switch is located on the back panel of the instrument. The switch is either on or off. The on position is for normal operation. The off position disconnects power to the entire unit.

Fan - The instrument utilizes a variable speed fan. Under certain circumstances, the fan may turn off. The fan shuts off at 100°C and above. Slots at the top and around the

9102S Dry-Well Calibrator

Front Panel

corners of the instrument are provided for airflow. The area around the calibrator must be kept clear to allow for adequate ventilation. The air is directed from the front to the back. Allow 6 inches of open space around the calibrator to allow adequate ventilation.

RS-232 - The RS-232 serial port provides a means for connecting the instrument to a computer or a printer using the included serial cable.



WARNING: Always leave enough clearance in front of the calibrator to allow for safe and easy installation and removal of probes.

4.2 Front Panel



Figure 3 Front Panel

Strap - A strap is provided to aid the user in carrying the instrument in one hand. Slide your hand into position and secure using the Velcro for a tight fit. Be careful when carrying the instrument while using the strap as inserts can fall out of the wells when tipped forward. Inspect the strap periodically for wear.

Well Block - Located on the middle of the front panel are the well openings where probes may be inserted into the well. The block is designed to accept temperature sensors up to 1/2" (12.7 mm) in diameter. The wells can be made to accept probes of smaller than 1/2" (12.7 mm) diameter by using optional inserts. Probes should fit snugly into the wells for best results.

Controller Display - The digital display is an important part of the temperature controller because it not only displays set and actual temperatures but also indicates various calibrator functions, settings, and constants. The display shows temperatures in units according to the selected scale °C or °F.

Controller Keypad - The four button keypad allows easy setting of the set-point temperature. The control buttons (SET, ▼, ▲, and EXIT) are used to set the calibrator temperature set-point, access and set other operating parameters, and access and set calibration parameters.

Setting the control temperature is done directly in degrees of the current scale. It can be set to one-tenth of a degree Celsius or Fahrenheit.

The functions of the buttons are as follows:

SET – Used to display the next parameter in the menu and to store parameters to the displayed value.

▼ (down arrow) – Used to decrement the displayed value of parameters.

▲ (up arrow) – Used to increment the displayed value.

EXIT – Used to exit a function and to skip to the next function. Any changes made to the displayed value are ignored.

4.3 Accessories

The table below lists optional inserts, carrying case, and battery packs by model number.

Table 3 Accessories

Model	Description
3102-0	Blank Insert
3102-1	1/16 (1.6 mm) Insert
3102-2	1/8 (3.2 mm) Insert
3102-8	5/32 (4.0 mm) Insert
3102-3	3/16 (4.8 mm) Insert
3102-4	1/4 (6.4 mm) Insert
3102-5	5/16 (7.9 mm) Insert
3102-6	3/8 (9.5 mm) Insert
3102-7	7/16 (11.1 mm) Insert
9308	Rugged Carrying Case
9320A	Battery Pack

Call your local Fluke representative for current pricing.

5 General Operation

5.1 Setting the Temperature

Section 6.2, Temperature Set-point, on page 19 explains in detail how to set the temperature set-point on the calibrator using the front panel keys. The procedure is summarized here.

1. Press “SET” twice to access the set-point value.
2. Press ▲ or ▼ to change the set-point value.
3. Press “SET” to program in the new set-point.
4. Press and hold “EXIT” to return to the temperature display.

When the set-point temperature is changed the controller switches the well heater on or off to raise or lower the temperature. The displayed well temperature gradually changes until it reaches the set-point temperature. The well may require 5 to 10 minutes to reach the set-point depending on the span. Another 5 to 10 minutes is required to stabilize within $\pm 0.05^{\circ}\text{C}$ of the set-point. Ultimate stability may take 15 to 20 minutes more of stabilization time.

5.2 Changing Display Units

This instrument can display temperature in Celsius or Fahrenheit. The temperature units are shipped from the factory set to Celsius. There are two ways to change to Fahrenheit or back to Celsius.

1 - Press the “SET” and ▲ simultaneously. The temperature display changes units.

or

1 - Press the “SET” key three times from the temperature display to show

$U n = \text{C}$

2 - Press the ▲ or ▼ key to change units.

3 - Press “SET” to save the setting or “EXIT” to continue without changing the setting.

6 Controller Operation

This chapter discusses in detail how to operate the dry-well temperature controller using the front control panel. Using the front panel key-switches and LED display the user may monitor the well temperature, set the temperature set-point in degrees C or F, monitor the heater output power, adjust the controller proportional band, and program the calibration parameters, operating parameters, and serial interface configuration. Operation of the functions and parameters are shown in the flowchart in Figure 4 on next page. This chart may be copied for reference.

In the following discussion a button with the word SET or EXIT inside, a ▲, or ▼, indicates the panel button while the dotted box indicates the display reading. Explanations of the button or display reading are to the right of each button or display value.

6.1 Well Temperature

The digital LED display on the front panel allows direct viewing of the actual well temperature. This temperature value is normally shown on the display. The units, C or F, of the temperature value are displayed at the right. For example,

100.0 C Well temperature in degrees Celsius

The temperature display function may be accessed from any other function by holding and releasing the “EXIT” button.

6.2 Temperature Set-point

The temperature set-point can be set to any value within the range and with resolution as given in the specifications. Be careful not to exceed the safe upper temperature limit of any device inserted into the well.

Setting the temperature involves selecting the set-point memory and adjusting the set-point value.

6.2.1 Programmable Set-points

The controller stores 8 set-point temperatures in memory. The set-points can be quickly recalled to conveniently set the calibrator to a previously programmed temperature set-point.

To set the temperature, first select the set-point memory. This function is accessed from the temperature display function by pressing “SET”. The number of the set-point memory currently being used is shown at the left on the display followed by the current set-point value.

100.0 C Well temperature in degrees Celsius



Access set-point memory

1 100. Set-point memory 1 location, 100°C currently used

9102S Dry-Well Calibrator
 Temperature Set-point

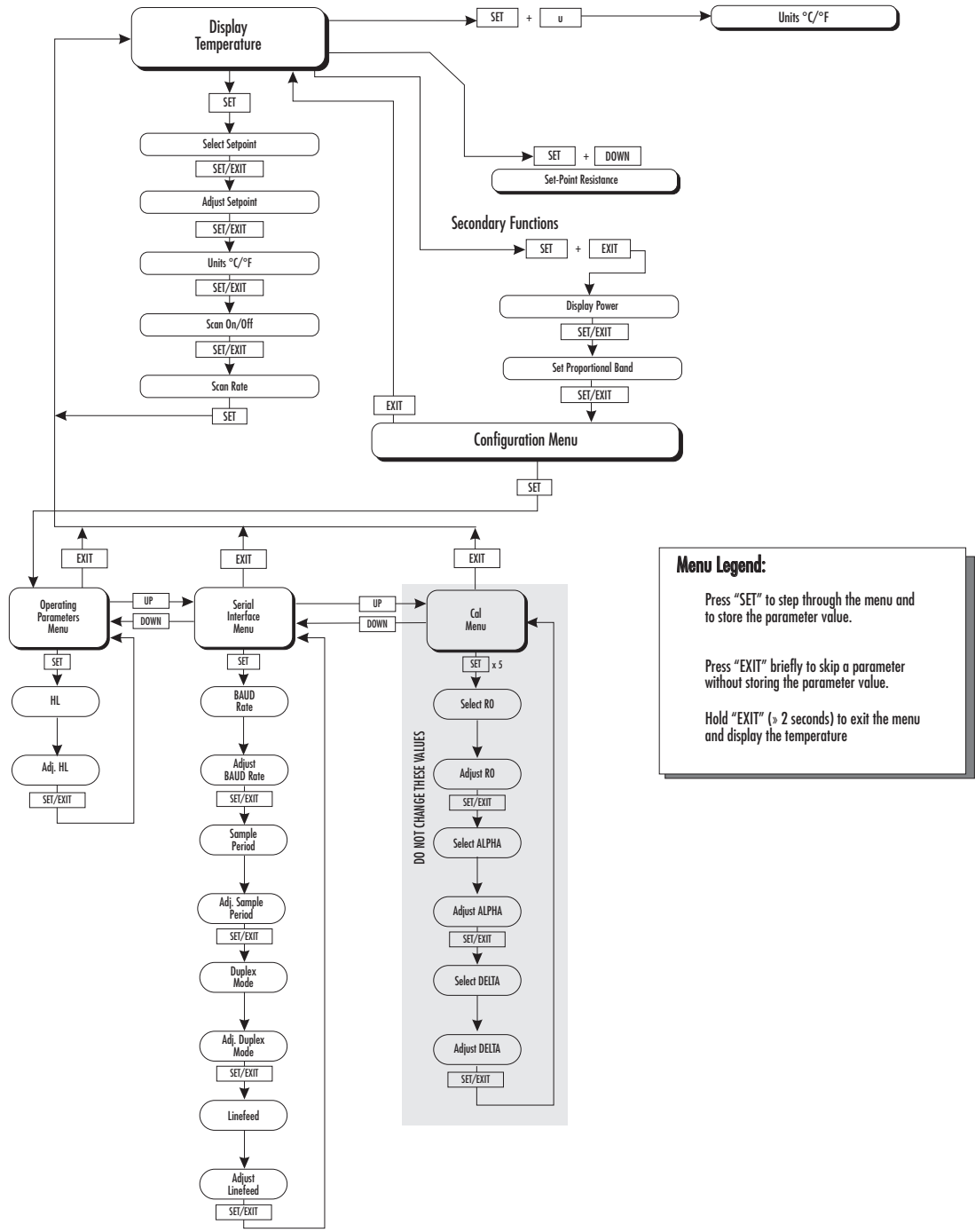

Figure 4 Controller operation flowchart

To change to another set-point memory press the up or down arrow.

4 50. *New set-point memory 4 location, 50°C*

Press “SET” to accept the new selection and access the set-point value. Press “EXIT” to continue and to ignore any changes.



Accept selected set-point memory

6.2.2 Set-point Value

The set-point value may be adjusted after selecting the set-point memory and pressing “SET”.

4 50. *Set-point 4 value in °C*

If the set-point value does not need to be changed, press and hold “EXIT” to resume displaying the well temperature. To change the set-point value, press “SET” and then press the up or down arrow.

50. *New set-point value*

When the desired set-point value is reached, press “SET” to accept the new value and access the temperature scale units selection. If “EXIT” is pressed, any changes made to the set-point are ignored.



Accept new set-point value

6.2.3 Temperature Scale Units

The temperature scale units of the controller maybe set by the user to degrees Celsius (°C) or Fahrenheit (°F). The units are used in displaying the well temperature, set-point, proportional band, and high limit.

Press “SET” after adjusting the set-point value to change display units.

U n = C *Scale units currently selected*

Press the up or down arrow to change the units.

U n = F *New units selected*

Press “SET” to accept the new units or “EXIT” to cancel.

Note: The temperature scale units may also be changed by pressing “SET” and ▲ when the temperature is displayed.

6.3 Scan

The scan rate can be set and enabled so that when the set-point is changed the dry-well heats or cools at a specified rate (degrees per minute) until it reaches the new set-point. With the scan disabled the dry-well heats or cools at the maximum possible rate.

6.3.1 Scan Control

The scan is controlled with the scan on/off function that appears in the main menu after the temperature scale units.

S c *Sc flashes for one second and then the current scan setting is displayed*

0 F F *Scan function off*

Press the up or down arrow to toggle the scan on or off.

0 n *Scan function on*

Press “SET” to accept the present setting and continue. Press “EXIT” to cancel.

 *Accept scan setting*

6.3.2 Scan Rate

The scan rate can be set from 0.1 to 99.9°C/min. The maximum scan rate, however, is actually limited by the natural heating or cooling rate of the instrument. This rate is often less than 100°C/min, especially when cooling.

The scan rate function appears in the main menu after the scan control function. The scan rate units are in degrees Celsius per minute, regardless of the selected units.

S r *Sr flashes for one second and then the current scan rate setting is displayed*

0 . 1 *Scan rate in°C/min*

Press the up or down arrow to change the scan rate.

2 . 0 *New scan rate*

Press “SET” to accept the new scan rate and continue. Press “EXIT” to cancel.

 *Accept scan rate*

6.4 Set-point Resistance

The set-point resistance is the resistance the instrument is trying to make the control sensor achieve and is calculated in the firmware using the set-point temperature. This value is not directly adjustable but is recalculated when the set-point temperature is

changed. The set-point resistance is used to perform a calibration adjustment using the Callendar-Van Dusen R versus T curve fit (see Section , Calibration Procedure). The instrument must be at temperature and stable prior to taking the set-point resistance reading. The set-point resistance can be displayed by pressing the “SET” and ▼ simultaneously. The set-point resistance is displayed as follows.

5 r E 5 5 r E 5 flashes for two seconds and then the whole number of the current set-point resistance setting is displayed

9 9 . Whole number portion of the set-point resistance flashes for two seconds and then the fraction portion of the current set-point resistance setting is displayed

. 2 2 2 Fraction portion of the current set-point resistance setting

The set-point resistance is 99.222.

6.5 Secondary Menu

Functions which are used less often are accessed within the secondary menu. The secondary menu is accessed by pressing “SET” and “EXIT” simultaneously and then releasing. The first function in the secondary menu is the heater power display. (See Figure .)

6.6 Heater Power

The temperature controller controls the temperature of the well by pulsing the heater on and off. The total power being applied to the heater is determined by the duty cycle or the ratio of heater on time to the pulse cycle time. By knowing the amount of heating, the user can tell if the calibrator is heating up to the set-point, cooling down, or controlling at a constant temperature. Monitoring the percent heater power, allows the user to know the stability of the well temperature. With good control stability the percent heating power should not fluctuate more than ±5% within one minute.

The heater power display is accessed in the secondary menu. Press “SET” and “EXIT” simultaneously and release. The heater power is displayed as a percentage of full power.

1 0 0 . 0 C Well temperature

 +  Access heater power in secondary menu

5 E C Flashes SEC for secondary menu and then displays the heater power

1 2 . 0 P Heater power in percent

To exit out of the secondary menu press “EXIT”. To continue on to the proportional band setting function press “SET”.

6.7 Proportional Band

In a proportional controller such as this, the heater output power is proportional to the well temperature over a limited range of temperatures around the set-point. This range of temperature is called the proportional band. At the bottom of the proportional band, the heater output is 100%. At the top of the proportional band, the heater output is 0. Thus, as the temperature rises the heater power is reduced, which consequently tends to lower the temperature back down. In this way the temperature is maintained at a constant level.

The temperature stability of the well and response time depend on the width of the proportional band. If the band is too wide, the well temperature deviates excessively from the set-point due to varying external conditions. This is because the power output changes very little with temperature and the controller cannot respond very well to changing conditions or noise in the system. If the proportional band is too narrow, the temperature may swing back and forth because the controller overreacts to temperature variations. For best control stability, the proportional band must be set for the optimum width.

The proportional band width is set at the factory as printed on the Report of Calibration. The proportional band width may be altered by the user if desired to optimize the control characteristics for a particular application.

The proportional band width is easily adjusted from the front panel. The width may be set to discrete values in degrees C or F depending on the selected units. The proportional band adjustment is accessed within the secondary menu. Press “SET” and “EXIT” to enter the secondary menu and show the heater power. Then press “SET” to access the proportional band.



Access heater power in secondary menu

SEC

Flashes SEC for secondary menu and then displays the heater power

12.0P

Heater power in percent



Access proportional band

PROP

Flashes prop and then displays the setting

4.1

Proportional band setting

To change the proportional band press ▲ or ▼.

10.0

New proportional band setting

To accept the new setting press “SET”. Press “EXIT” to continue without storing the new value.



Accept the new proportional band setting

6.8 Controller Configuration

The controller has a number of configuration and operating options and calibration parameters which are programmable via the front panel. These are accessed from the secondary menu after the proportional band function by pressing “SET”. Pressing “SET” again enters the first of three sets of configuration parameters — operating parameters, serial interface parameters, and calibration parameters. The menus are selected using the up and down arrows and then pressing “SET”.

6.9 Operating Parameters

The operating parameters menu is indicated by,

P A r Operating parameters menu

The operating parameters menu contains the High Limit parameter.

6.10 High Limit

The High Limit parameter adjusts the upper set-point temperature. The factory default and maximum are set to 125°C (257°F). The minimum setting is 50°C (122°F). For safety, a user can adjust the High Limit down so the maximum temperature set-point is restricted.

H L Flashes HL and then displays the setting

125 Flashes the current value and then displays the value for adjustment

125 Current High Limit setting

Press the ▲ or ▼ to adjust the setting.

100 New High Limit setting

To accept the new setting, press “SET”. Press “EXIT” to continue without storing the new value.



Accept the new High Limit setting

6.11 Serial Interface Parameters

The serial RS-232 interface parameters menu is indicated by,

S E r L Serial RS-232 interface parameters menu

Press “SET” to enter the menu. The serial interface parameters menu contains parameters which determine the operation of the serial interface. The parameters in the menu are — baud rate, sample period, duplex mode, and linefeed.

9102S Dry-Well Calibrator

Serial Interface Parameters

6.11.1 Baud Rate

The baud rate is the first parameter in the menu. The baud rate setting determines the serial communications transmission rate.

The baud rate parameter is indicated by,

BAUD *Flashes BAUD for one second and then displays the setting*

2400b *Current baud rate*

The BAUD rate of the serial communications may be programmed to 300, 600, 1200, **2400** (default), 4800, or 9600 BAUD. Use the up or down arrows to change the BAUD rate value.

4800 b *New baud rate*

Press “SET” to accept the new setting or “EXIT” to abort the operation and skip to the next parameter in the menu.

6.11.2 Sample Period

The sample period is the next parameter in the serial interface parameter menu. The sample period is the time period in seconds between temperature measurements transmitted from the serial interface. If the sample rate is set to 5, the instrument transmits the current measurement over the serial interface approximately every five seconds. The automatic sampling is disabled with a sample period of 0. The sample period is indicated by,

SPEr *Flashes for one second and then the serial sample period setting is displayed*

1 *Current sample period (seconds)*

Adjust the value by using the up or down arrows (▲ ▼).

50 *New sample period*

Press “SET” to accept the new setting or “EXIT” to abort the operation and skip to the next parameter in the menu.

6.11.3 Duplex Mode

The next parameter is the duplex mode. The duplex mode may be set to full duplex or half duplex. With full duplex any commands received by the calibrator via the serial interface are immediately echoed or transmitted back to the device of origin. With half duplex the commands are executed but not echoed. The duplex mode parameter is indicated by,

DUP L *Flashes for one second and then the serial duplex mode setting is displayed*

FULL *Current duplex mode setting*

The mode may be changed using the up or down arrows (▲ ▼).

HRLF *New duplex mode setting*

Press “SET” to accept the new setting or “EXIT” to abort the operation and skip to the next parameter in the menu.

6.11.4 Linefeed

The final parameter in the serial interface menu is the linefeed mode. This parameter enables (on) or disables (off) transmission of a linefeed character (LF, ASCII 10) after transmission of any carriage-return. The linefeed parameter is indicated by,

LF *Flashes for one second and then the serial linefeed setting is displayed*

On *Current linefeed setting*

The mode may be changed using the up or down arrows (▲ ▼).

Off *New linefeed setting*

Press “SET” to accept the new setting or “EXIT” to abort the operation and skip to the next parameter in the menu.

6.12 Calibration Parameters

The operator of the instrument controller has access to a number of the calibration constants: R0, ALPHA, and DELTA. These values are set at the factory and must not be altered. The correct values are important to the accuracy and proper and safe operation of the instrument. Access to these parameters is available to the user so that in the event that the controller memory fails the user may restore these values to the factory settings. The user should have a list of these constants and their settings with the instrument manual.



CAUTION: *DO NOT change the values of the instrument calibration constants from the factory set values. The correct setting of these parameters is important to the safety, proper operation, and performance of the instrument.*

The calibration parameters menu is indicated by,

CR L *Calibration parameters menu*

Press “SET” five times to enter the menu. The calibration parameters menu contains the parameters, Hard Cutout, R0, ALPHA, and DELTA, which characterize the resistance-temperature relationship of the platinum control sensor. These parameters may be adjusted to improve the accuracy of the calibrator.

The calibration parameters are accessed by pressing “SET” after the name of the parameter is displayed. The value of the parameter may be changed using the up or down arrow. After the desired value is reached, press “SET” to set the parameter to the new value. Pressing “EXIT” causes the parameter to be skipped ignoring any changes that may have been made.

6.12.1 R0

This probe parameter refers to the resistance of the control probe at 0°C. The value of this parameter is set at the factory for best instrument accuracy. The value ranges from 95 to 105. For values greater than 100.000, the display does not show the hundreds placement. For values less than 100.000, the display shows the entire value. The R0 parameter is indicated by,

R 0 *Flashes for one second and then the R0 setting is displayed*

00.014 *Current R0 setting (100.014)*

To change the R0 setting, press the up or down arrows.

99.999 *New R0 setting*

To accept the new setting, press “SET”. Press “EXIT” to continue without storing the new value.

 *Accept the new R0 setting*

6.12.2 ALPHA

This probe parameter refers to the average sensitivity of the probe between 0 and 100°C. The value of this parameter is set at the factory for best instrument accuracy.

ALPHA *Flashes for one second and then the ALPHA setting is displayed*

38530 *Current ALPHA setting*

To change the ALPHA setting, press the up or down arrows.

38600 *New ALPHA setting*

To accept the new setting, press “SET”. Press “EXIT” to continue without storing the new value.

 *Accept the new ALPHA setting*

6.12.3 DELTA

This probe parameter characterizes the curvature of the resistance-temperature relationship of the sensor. The value of this parameter is set at the factory for best instrument accuracy.

DELTA *Flashes for one second and then the DELTA setting is displayed*

0.0000 *Current DELTA setting*

To change the DELTA setting, press the up or down arrows.

0.1000 *New DELTA setting*

To accept the new setting, press “SET”. Press “EXIT” to continue without storing the new value.



Accept the new DELTA setting

7 Digital Communication Interface

This instrument is capable of communicating with and being controlled by other equipment through the digital serial interface.

With a digital interface, the instrument may be connected to a computer or other equipment. This allows the user to set the set-point temperature, monitor the temperature, and access any of the other controller functions, all using remote communications equipment. Communications commands are summarized in Table 4 on next page.

7.1 RS-232 Connection

The three-conductor jack for the serial port is located on the back of the instrument. One serial cable is included. Additional or longer cables, of three meters or less, can be constructed by following the wiring diagram shown in Figure 5 on this page. **Note:** The Tx/D line on one side connects to the Rx/D line on the other and vice-versa. To reduce the possibility of electrical interference, the serial cable should be shielded with low resistance between the connector and the shield and should not be much longer than is necessary. The protocol for serial communications is 8 data bits, 1 stop bit, and no parity. Use no flow control. Set the linefeed to ON (all carriage returns are followed by a linefeed (LF, ASCII 10)), and the duplex to HALF, disabling echo.

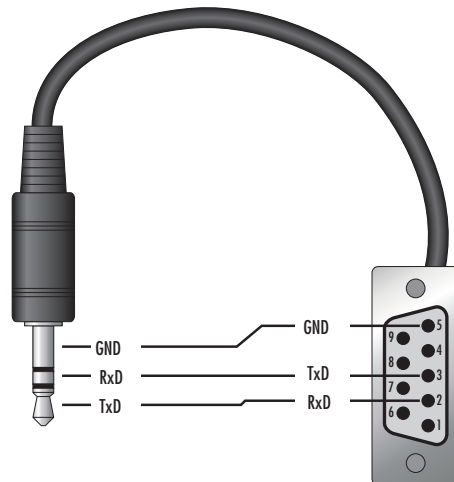

Figure 5 Serial Cable Wiring

The serial port can be used to transmit measurements to a computer or printer or to change settings of the instrument from a computer. A full list of commands follows in Section 7.2, Interface Commands, on page 32.

Commands sent to the instrument must end with an EOS character which is a carriage return (CR, ASCII 13) or linefeed character (LF, ASCII 10). Commands can be sent with upper or lower case letters. Data returned from the instrument end with a carriage return. If the linefeed setting is on, a linefeed is also sent after the carriage return.

9102S Dry-Well Calibrator

Interface Commands

7.2 Interface Commands

The various commands for accessing the calibrator functions via the digital interface are listed in this section (see Table 4 on this page). These commands are used with the RS-232 serial interface. The commands are terminated with a carriage-return character (CR, ASCII 13). The interface makes no distinction between upper and lower case letters, hence either may be used. Commands may be abbreviated to the minimum number of letters which determines a unique command. A command may be used to either set a parameter or display a parameter depending on whether or not a value is sent with the command following a “=” character. For example “s” returns the current set-point and “s=120.0” sets the set-point to 120.0 degrees.

In the following list of commands, characters or data within brackets, “[” and “]”, are optional for the command. A slash, “/”, denotes alternate characters or data. Numeric data, denoted by “n”, may be entered in decimal or exponential notation. Characters are shown in lower case although upper case may be used. Spaces may be added within command strings and will simply be ignored. Backspace (BS, ASCII 8) may be used to erase the previous character. A terminating carriage return (CR, ASCII 13) is implied with all commands.

Table 4 Controller communications commands

Command Description	Command Format	Command Example	Returned	Returned Example	Acceptable Values
Display Temperature					
Read current set-point	s[etpoint]	s	set: 999.99 {C or F}	set: 75.00 C	
Set current set-point to n	s[etpoint]=n t[emperature]=n	s=100 t=100			-10 to 122°C 14 to 252°F
Read temperature	t[emperature]	t	t: 999.9 {C or F}	t: 55.6 C	
Read temperature units	u[nits]	u	u: x	u: C	
Set temperature units:	u[nits]=c/f				C or F
Set temperature units to Celsius	u[nits]=c	u=c			
Set temperature units to Fahrenheit	u[nits]=f	u=f			
Read scan mode	sc[an]	sc	sc: {ON or OFF}	sc: ON	
Set scan mode	sc[an]=on/off	sc=on			ON or OFF
Read scan rate	sr[ate]	sr	srat: 99.9 {C or F}/min	srat:12.4 C/min	
Set scan rate	sr[ate]=n	sr=1.1			0.1 to 99.9°C 0.2 to 179.8°F
Secondary Menu					
Read proportional band setting	pr[op-band]	pr	pb: 999.99999	pb: 15.9	
Set proportional band to n	pr[op-band]=n	pr=8.83			0.1 to 30°C 0.2 to 54°F
Read heater power (duty cycle)	po[wer]	po	po: 999.9	po: 6.5	
Configuration Menu					
Operating Parameters Menu					
Read High Limit	hl[imit]	hl	hl: 9999	hl: 125	
Set High Limit	hl[imit]=n	hl=100			50 to 125°C 122 to 257°F

Digital Communication Interface
Interface Commands

Command Description	Command Format	Command Example	Returned	Returned Example	Acceptable Values
Serial Interface Menu					
Read serial sample setting	sa[mple]	sa	sa: 99999	sa: 1	
Set serial sampling setting to <i>n</i> seconds	sa[mple]= <i>n</i>	sa=0			0 to 10,000
Set serial duplex mode:	du[plex]=f[ull]/h[alf]				FULL or HALF
Set serial duplex mode to full	du[plex]=f[ull]	du=f			
Set serial duplex mode to half	du[plex]=h[alf]	du=h			
Set serial linefeed mode:	lf[eed]=on/off[f]				ON or OFF
Set serial linefeed mode to on	lf[eed]=on	lf=on			
Set serial linefeed mode to off	lf[eed]=off[f]	lf=of			
Calibration Menu					
Read R0 calibration parameter	r[0]	r	r0: 999.999	r0: 100.7	
Set R0 calibration parameter to <i>n</i>	r[0]= <i>n</i>	r=100.7			95.0 to 105.0
Read ALPHA calibration parameter	al[pha]	al	al: 9.99999999	al: 0.003865	
Set ALPHA calibration parameter to <i>n</i>	al[pha]= <i>n</i>	al=0.003865			0.002 to 0.006
Read DELTA calibration parameter	de[lta]	de		de: 1.50	
Set DELTA calibration parameter	de[lta]= <i>n</i>	de=1.37	de: 9.99999		0.0–3.0
Miscellaneous Other Commands					
Read firmware version number	*ver[sion]	*ver	ver.9999x,9.99	ver.9102S,1.10	
Read structure of all commands	h[elp]	h	list of commands		
Read ALL operating parameters	all	all	list of parameters		
Read set-point	*sr	*sr	999.999 ohms	100.123 ohms	

Legend: [] Optional command data
 {} Returns either information
n Numeric data supplied by user
 9 Numeric data returned to user
 x Character data returned to user

Note: When DUPLEX is set to FULL and a command is sent to READ, the command is returned followed by a carriage return and linefeed. Then the value is returned as indicated in the RETURNED column.

8 Test Probe Calibration

For optimum accuracy and stability, allow the calibrator to warm up for 10 minutes after power-up and then allow adequate stabilization time after reaching the set-point temperature. After completing operation of the calibrator, allow the well to cool by setting the temperature to 25°C for one-half hour before switching the power off.

8.1 Calibrating a Single Probe

Insert the probe to be calibrated into the well of the instrument. The probe should fit snugly into the calibrator probe sleeve yet should not be so tight that it cannot be easily removed. Avoid any dirt or grit that may cause the probe to jam into the sleeve. Best results are obtained with the probe inserted to the full depth of the well. Once the probe is inserted into the well, allow adequate stabilization time to allow the test probe temperature to settle as described above. Once the probe has settled to the temperature of the well, it may be compared to the calibrator display temperature. The display temperature should be stable to within $\pm 0.05^\circ\text{C}$ degree for best results.



CAUTION: *Never allow foreign material into the wells of the block. Fluids and other materials can damage the instrument causing binding and damage to your probe.*

8.2 Dry-well Characteristics

There is a temperature gradient vertically in the test well. The heater has been applied to the block in such a way as to compensate for nominal heat losses out of the top of the dry-well. However, actual heat losses vary with design of the thermometer probes inserted into the calibrator and the temperature. For best results, insert probe to full depth of well.

8.2.1 Stabilization and Accuracy

The stabilization time of the instrument depends on the conditions and temperatures involved. Typically, the test well stabilizes to $\pm 0.05^\circ\text{C}$ within 7 minutes of reaching the set-point temperature as indicated by the display. Ultimate stability is achieved 10 to 20 minutes after reaching the set temperature.

Depending on the magnitude of the disturbance and the required accuracy, inserting a cold probe into a warm well will require another stabilization period. For example, inserting a 0.25 inch diameter room temperature probe into a sleeve at 120°C takes 7 minutes to be within $\pm 0.05^\circ\text{C}$ of its settled point and might take 15 minutes to achieve maximum stability.

Speeding up the calibration process can be accomplished by knowing how soon to make the measurement. It is recommended that typical measurements be made at the desired temperatures with the desired test probes to establish these times.

9 Calibration Procedure



Note: This procedure is to be considered a general guideline. Each laboratory should write their own procedure based on their equipment and their quality program. Each procedure should be accompanied by an uncertainty analysis also based on the laboratory's equipment and environment.

Sometimes the user may want to calibrate the dry-well to improve the temperature set-point accuracy. Calibration is done by adjusting the controller probe calibration constants **R0**, **ALPHA**, and **DELTA** so that the temperature of the dry-well as measured with a standard thermometer agrees more closely with the set-point. The thermometer used must be able to measure the well temperature with higher accuracy than the desired accuracy of the dry-well. By using a good thermometer and following this procedure the dry-well can be calibrated to an accuracy of better than 0.25°C over its full range.

9.1 Calibration Points

In calibrating the dry-well, **R0**, **ALPHA**, and **DELTA** are adjusted to minimize the set-point error at each of three different dry-well temperatures. Any three reasonably separated temperatures may be used for the calibration. Improved results can be obtained for shorter ranges when using temperatures that are just within the most useful operating range of the dry-well. The farther apart the calibration temperatures, the greater the calibrated temperature range. However, the calibration error is also greater over the range. For instance, if 10°C to 100°C is chosen as the calibration range, the calibrator may achieve an accuracy of ±0.25°C over the range 10°C to 100°C. Choosing a range of 50°C to 100°C may allow the calibrator to have a better accuracy of maybe ±0.2°C over the range 75°C to 105°C but outside that range the accuracy may be only ±0.25°C.

9.2 Calibration Procedure

1. Choose three set-points to use in the calibration of the R0, ALPHA, and DELTA parameters. These set points are generally 2°C, 50°C, and 100°C but other set points may be used if desired or necessary.
2. Set the dry-well to the lowest set-point. When the dry-well reaches the set-point and the display is stable, wait 15 minutes or so and then take a reading from the thermometer. Sample the set-point resistance by holding down “SET” and pressing the ▼. Write these values down as T₁ and R₁ respectively.
3. Repeat step 2 for the other two set-points recording them as T₂ and R₂ and T₃ and R₃ respectively.
4. Using the recorded data, calculate new values for the R0, ALPHA, and DELTA.

9.2.1 Compute DELTA

$$A = T_3 - T_2$$

9102S Dry-Well Calibrator

Calibration Procedure

$$B = T_2 - T_1$$

$$C = \left[\frac{T_3}{100} \right] \left[1 - \frac{T_3}{100} \right] - \left[\frac{T_2}{100} \right] \left[1 - \frac{T_2}{100} \right]$$

$$D = \left[\frac{T_2}{100} \right] \left[1 - \frac{T_2}{100} \right] - \left[\frac{T_1}{100} \right] \left[1 - \frac{T_1}{100} \right]$$

$$E = R_3 - T_2$$

$$F = R_2 - T_1$$

$$\text{delta} = \frac{AF - BE}{DE - CF}$$

$T_{1,3}$ - Measured temperature using thermometer.

$R_{1,3}$ - Value of set-point resistance from the instrument display. (Press “SET” and ▼ at the same time.)

where

T_1 and R_1 are the measured temperature and set-point resistance at 2.0 °C

T_2 and R_2 are the measured temperature and set-point resistance at 50.0 °C

T_3 and R_3 are the measured temperature and set-point resistance at 100.0 °C

9.2.2 Compute R0 and ALPHA

$$a_1 = T_1 + \text{delta} \left[\frac{T_1}{100} \right] \left[1 - \frac{T_1}{100} \right]$$

$$a_3 = T_3 + \text{delta} \left[\frac{T_3}{100} \right] \left[1 - \frac{T_3}{100} \right]$$

$$rzero = \frac{R_3 a_1 - R_1 a_3}{a_1 - a_3}$$

$$\text{alpha} = \frac{R_1 - R_3}{R_3 a_1 - R_1 a_3}$$

delta is the new value of DELTA computed above

Program the new values for DELTA (delta), R0 (rzero), and ALPHA (alpha) into the dry-well using the following steps.

5. Press “SET” and “EXIT” at the same time. Press “SET” until *P R R* is displayed. and then press ▲ until *CLL* is displayed.
6. Press “SET” five times to enter the menu.
7. Press “SET” and ▲ or ▼ until the correct numerical setting is displayed. Press “SET” to accept the new value.
8. Repeat step 3. for ALPHA and DELTA.
9. Press “EXIT” to show the displayed temperature.

9.2.3 Accuracy and Repeatability

Check the accuracy of the dry-well at various points over the calibration range. If dry-well does not pass specification at all set-points, repeat the Calibration Procedure.

10 Maintenance

- This instrument has been designed with the utmost care. Ease of operation and simplicity of maintenance have been a central theme in the product development. Therefore, with proper care the instrument should require very little maintenance. Avoid operating the instrument in an oily, wet, dirty, or dusty environment.
- If the outside of the instrument becomes soiled, it may be wiped clean with a damp cloth and mild detergent. Do not use harsh chemicals on the surface which may damage the paint.
- It is important to keep the well of the calibrator clean and clear of any foreign matter. Do not use fluid to clean out the well.
- Use a commercially available plastic or felt brush, of appropriate diameter for a tight fit without any fluid, to clean the well. Complete the cleaning process by using cotton swabs and air to remove any debris.
- Inserts should be cleaned periodically. For cold dry-wells operating below 0°C, you should always clean the inserts after operating the unit at or below 0°C. Use emery cloth or other similar material to clean the outside of the inserts. Ensure that the inserts are wiped clean of any debris loosened in the buffing process. Periodic cleaning of the outside of the inserts ensures easy insertion and removal of the inserts from the well.
- The dry-well calibrator should be handled with care. Avoid knocking or dropping the calibrator.
- Do not drop the probe stems into the well. This type of action can cause a shock to the sensor.
- If a hazardous material is spilt on or inside the equipment, the user is responsible for taking the appropriate decontamination steps as outlined by the national safety council with respect to the material.
- If the mains supply cord becomes damaged, replace it with a cord with the appropriate gauge wire for the current of the instrument. If there are any questions, call an Authorized Service Center (see Section 1.4, Authorized Service Centers, on page 6) for more information.
- Before using any cleaning or decontamination method except those recommended by Fluke, users should check with an Authorized Service Center to be sure that the proposed method will not damage the equipment.
- If the instrument is used in a manner not in accordance with the equipment design, the operation of the dry-well may be impaired or safety hazards may arise.

11 Troubleshooting

This section contains information on troubleshooting, CE Comments, and a wiring diagram.

11.1 Troubleshooting Problems, Possible Causes, and Solutions

In the event that the instrument appears to function abnormally, this section may help to find and solve the problem. Several possible problem conditions are described along with likely causes and solutions. If a problem arises, please read this section carefully and attempt to understand and solve the problem. If the problem cannot otherwise be solved, contact an Authorized Service Center (see Section 1.4, Authorized Service Centers, on page 6) for assistance. Be sure to have the model number, serial number, voltage, and problem description available.

Problem	Possible Causes and Solutions
Incorrect temperature reading	<p>Incorrect R0, ALPHA, and DELTA parameters. Find the value for R0, ALPHA, and DELTA on the Report of Calibration. Reprogram the parameters into the instrument (see Section , Calibration Parameters). Allow the instrument to stabilize and verify the accuracy of the temperature reading.</p> <p>Controller locked up. The controller may have locked up due to a power surge or other aberration. Initialize the system by performing the Factory Reset Sequence.</p> <p>Factory Reset Sequence. Hold the SET and EXIT buttons down at the same time while powering up the instrument. The instrument displays shows '-init-'; the model number, and the firmware version. Each of the controller parameters and calibration constants must be reprogrammed. The values can be found on the Report of Calibration (see Section 6.12, Calibration Parameters, on page 27).</p>
The instrument heats or cools too quickly or too slowly	<p>Incorrect scan and scan rate settings. The scan and scan rate settings may be set to unwanted values. Check the Scan and Scan Rate settings. The scan may be off (if the unit seems to be responding too quickly). The scan may be on with the Scan Rate set low (if unit seems to be responding too slowly).</p> <p>Improper line voltage. Verify that the voltage reading in the bottom of the unit matches the source voltage.</p>
Unstable display	<p>Wait. Allow the instrument to stabilize for a few minutes.</p> <p>Proportional band may be incorrect. Refer to the proportional band on the Report of Calibration.</p>
The display shows an error code	<p>Controller problem. The error messages signify the following problems with the controller.</p> <p><i>Err 1</i> - a RAM error <i>Err 2</i> - a NVRAM error <i>Err 3</i> - a Structure error <i>Err 4</i> - an ADC setup error <i>Err 5</i> - an ADC ready error <i>Err 6</i> - a defective control sensor <i>Err 7</i> - a heater error</p> <p>Initialize the system by performing the Factory Reset Sequence describe above.</p>
Temperature cannot be set above a certain point	<p>Incorrect High Limit parameter. The High Limit parameter may be set below 125°C. Check this value as described in Section 6.9, Operating Parameters, on page 25.</p>
Display is reading incorrectly	<p>The instrument was turned off at high temperatures and reenergized too quickly. Turn the instrument off until the display is completely off and then reenergize.</p>
Display flickers when the instrument is turned off	<p>This is normal operation and is more prevalent at high temperatures due to Seebeck Coefficient of the thermoelectric cooling devices. Some time is required to fully discharge the switching power supply and to complete the power off cycle.</p>

9102S Dry-Well Calibrator

CE Comments

Problem	Possible Causes and Solutions
The instrument does not reach temperature	The specifications for the instrument include an ambient temperature of 23°C. If the ambient temperature is above 23°C, the instrument may not be able to reach the lowest specified temperature. Check the ambient temperature if the instrument does not reach maximum temperature.

11.2 CE Comments

11.2.1 EMC Directive

Fluke's equipment has been tested to meet the European Electromagnetic Compatibility Directive (EMC Directive, 89/336/EEC). The Declaration of Conformity for your instrument lists the specific standards to which the unit was tested.

11.2.2 Low Voltage Directive (Safety)

In order to comply with the European Low Voltage Directive (73/23/EEC), Fluke equipment has been designed to meet the IEC 1010-1 (EN 61010-1) and the IEC 1010-2-010 (EN 61010-2-010) standards.

FLUKE®

725

Multifunction Process Calibrator

Users Manual

October, 1998 Rev.3, 5/04

© 1998-2004 Fluke Corporation, All rights reserved.

All product names are trademarks of their respective companies.

LIMITED WARRANTY AND LIMITATION OF LIABILITY

Each Fluke product is warranted to be free from defects in material and workmanship under normal use and service. The warranty period is three years and begins on the date of shipment. Parts, product repairs, and services are warranted for 90 days. This warranty extends only to the original buyer or end-user customer of a Fluke authorized reseller, and does not apply to fuses, disposable batteries, or to any product which, in Fluke's opinion, has been misused, altered, neglected, contaminated, or damaged by accident or abnormal conditions of operation or handling. Fluke warrants that software will operate substantially in accordance with its functional specifications for 90 days and that it has been properly recorded on non-defective media. Fluke does not warrant that software will be error free or operate without interruption.

Fluke authorized resellers shall extend this warranty on new and unused products to end-user customers only but have no authority to extend a greater or different warranty on behalf of Fluke. Warranty support is available only if product is purchased through a Fluke authorized sales outlet or Buyer has paid the applicable international price. Fluke reserves the right to invoice Buyer for importation costs of repair/replacement parts when product purchased in one country is submitted for repair in another country.

Fluke's warranty obligation is limited, at Fluke's option, to refund of the purchase price, free of charge repair, or replacement of a defective product which is returned to a Fluke authorized service center within the warranty period.

To obtain warranty service, contact your nearest Fluke authorized service center to obtain return authorization information, then send the product to that service center, with a description of the difficulty, postage and insurance prepaid (FOB Destination). Fluke assumes no risk for damage in transit. Following warranty repair, the product will be returned to Buyer, transportation prepaid (FOB Destination). If Fluke determines that failure was caused by neglect, misuse, contamination, alteration, accident, or abnormal condition of operation or handling, including overvoltage failures caused by use outside the product's specified rating, or normal wear and tear of mechanical components, Fluke will provide an estimate of repair costs and obtain authorization before commencing the work. Following repair, the product will be returned to the Buyer transportation prepaid and the Buyer will be billed for the repair and return transportation charges (FOB Shipping Point).

THIS WARRANTY IS BUYER'S SOLE AND EXCLUSIVE REMEDY AND IS IN LIEU OF ALL OTHER WARRANTIES, EXPRESS OR IMPLIED, INCLUDING BUT NOT LIMITED TO ANY IMPLIED WARRANTY OF MERCHANTABILITY OR FITNESS FOR A PARTICULAR PURPOSE. FLUKE SHALL NOT BE LIABLE FOR ANY SPECIAL, INDIRECT, INCIDENTAL OR CONSEQUENTIAL DAMAGES OR LOSSES, INCLUDING LOSS OF DATA, ARISING FROM ANY CAUSE OR THEORY.

Since some countries or states do not allow limitation of the term of an implied warranty, or exclusion or limitation of incidental or consequential damages, the limitations and exclusions of this warranty may not apply to every buyer. If any provision of this Warranty is held invalid or unenforceable by a court or other decision-maker of competent jurisdiction, such holding will not affect the validity or enforceability of any other provision.

Fluke Corporation
P.O. Box 9090
Everett, WA 98206-9090
U.S.A.

Fluke Europe B.V.
P.O. Box 1186
5602 BD Eindhoven
The Netherlands

11/99

Table of Contents

Title	Page
Introduction.....	1
Contacting Fluke.....	1
Standard Equipment.....	3
Safety Information.....	3
Getting Acquainted with the Calibrator	8
Input and Output Terminals	8
Keys.....	10
Display	13
Getting Started	14
Shut Down Mode	14
Contrast Adjustment	16
Using Measure Mode.....	17
Measuring Electrical Parameters (Upper Display)	17
Current Measurement with Loop Power.....	17
Measuring Electrical Parameters (Lower Display)	19
Measuring Temperature.....	20

Using Thermocouples	20
Using Resistance-Temperature Detectors (RTDs)	23
Measuring Pressure	26
Zeroing with Absolute Pressure Modules	27
Using Source Mode	29
Sourcing 4 to 20 mA	29
Simulating a 4- to 20-mA Transmitter	29
Sourcing Other Electrical Parameters	29
Simulating Thermocouples	32
Simulating RTDs.....	32
Sourcing Pressure	35
Setting 0 % and 100 % Output Parameters	37
Stepping and Ramping the Output	37
Manually Stepping the mA Output.....	37
Auto Ramping the Output.....	38
Storing and Recalling Setups.....	38
Calibrating a Transmitter	39
Calibrating a Pressure Transmitter.....	41
Calibrating an I/P Device.....	43
Testing an Output Device.....	45
Remote Control Commands.....	46
Replacing the Batteries	49
Replacing the Fuses	49
Maintenance.....	50
Cleaning the Calibrator.....	50
Service Center Calibration or Repair.....	50
Replacement Parts	51
Accessories.....	53

Contents (continued)

External Fluke Pressure Module Compatibility	53
Specifications.....	56
DC Voltage Measurement.....	56
DC Voltage Source	56
Millivolt Measurement and Source*.....	56
DC mA Measurement and Source	57
Ohms Measurement.....	57
Ohms Source	57
Frequency Measurement	57
Frequency Source.....	58
Temperature, Thermocouples.....	58
Loop Power Supply.....	59
RTD Excitation (simulation)	59
Temperature, RTD Ranges, and Accuracies (ITS-90)	59
Pressure Measurement.....	60
General Specifications.....	60

725

Users Manual



List of Tables

Table	Title	Page
1.	Summary of Source and Measure Functions.....	2
2.	International Symbols	7
3.	Input/Output Terminals and Connectors.....	9
4.	Key Functions	11
5.	Thermocouple Types Accepted	21
6.	RTD Types Accepted.....	24
7.	mA Step Values	38
8A.	Remote Control Upper Display	46
8B.	Remote Control Lower Display	46
8C.	"S" Commands Select Sensor Type	48
9.	Replacement Parts	51
10.	Fluke Pressure Module Compatibility	53
11.	Pressure Modules.....	54



List of Figures

Figure	Title	Page
1.	Standard Equipment	6
2.	Input/Output Terminals and Connectors	8
3.	Keys	10
4.	Elements of a Typical Display	13
5.	Voltage-to-Voltage Test	15
6.	Adjusting the Contrast	16
7.	Measuring Voltage and Current Output	17
8.	Connections for Supplying Loop Power	18
9.	Measuring Electrical Parameters	19
10.	Measuring Temperature with a Thermocouple	22
11.	Measuring Temperature with an RTD, Measuring 2-, 3-, and 4-Wire Resistance	25
12.	Gage and Differential Pressure Modules	26
13.	Connections for Measuring Pressure	28
14.	Connections for Simulating a 4- to 20-mA Transmitter	30
15.	Electrical Sourcing Connections	31
16.	Connections for Simulating a Thermocouple	33
17.	Connection for Simulating a 3-Wire RTD	34

18.	Connections for Sourcing Pressure.....	36
19.	Calibrating a Thermocouple Transmitter.....	40
20.	Calibrating a Pressure-to-Current (P/I) Transmitter.....	42
21.	Calibrating a Current-to-Pressure (I/P) Transmitter.....	44
22.	Calibrating a Chart Recorder.....	45
23.	Replacing the Batteries.....	50
24.	Replacement Parts.....	52

Multifunction Process Calibrator

Introduction

Your Fluke 725 Multifunction Process Calibrator (referred to as “the calibrator”) is a handheld, battery-operated instrument that measures and sources electrical and physical parameters. See Table 1.

In addition to the functions in Table 1, the calibrator has the following features and functions:

- A split-screen display. The upper display allows you to measure volts, current, and pressure only. The lower display allows you to measure and source volts, current, pressure, resistance temperature detectors, thermocouples, frequency, and ohms.
 - Calibrates a transmitter using the split-screen.
 - A thermocouple (TC) input/output terminal and internal isothermal block with automatic reference-junction temperature compensation.
 - Stores and recalls setups.
- Manual stepping and automatic stepping and ramping.
 - Controls the calibrator remotely from a PC running a terminal emulator program.

Table 1. Summary of Source and Measure Functions

Function	Measure	Source
dc V	0 V to 30 V	0 V to 10 V
dc mA	0 to 24 mA	0 to 24 mA
Frequency	1 CPM to 10 kHz	1 CPM to 10 kHz
Resistance	0 Ω to 3200 Ω	15 Ω to 3200 Ω
Thermocouple	Types E, J, K, T, B, R, S, L, U, N, mV	
RTD (Resistance- Temperature Detector)	Pt100 Ω (385) Pt100 Ω (3926) Pt100 Ω (3916) Pt200 Ω (385) Pt500 Ω (385) Pt1000 Ω (385) Ni120	
Pressure	27 modules ranging from 10 in. H ₂ O to 10,000 psi	27 modules ranging from 10 in. H ₂ O to 10,000 psi using an external pressure source (hand pump)
Other functions	Loop supply, Step, Ramp, Memory, Dual display	

Standard Equipment

The items listed below and shown in Figure 1 are included with your calibrator. If the calibrator is damaged or something is missing, contact the place of purchase immediately. To order replacement parts or spares, see the user-replaceable parts list in Table 9.

- TL75 test leads (one set)
- AC70A alligator clips (one set)
- Stackable alligator clip test leads (one set)
- *725 Product Overview Manual*
- *725 CD-ROM* (contains Users Manual)
- Spare fuse

Safety Information

The calibrator is designed in accordance with IEC1010-1, ANSI/ISA S82.01-1994 and CAN/CSA C22.2 No. 1010.1-92. Use the calibrator only as specified in this manual, otherwise the protection provided by the calibrator may be impaired.

A **Warning** identifies conditions and actions that pose hazard(s) to the user; a **Caution** identifies conditions and actions that may damage the calibrator or the equipment under test.

International symbols used on the calibrator and in this manual are explained in Table 2.

⚠ Warning

To avoid possible electric shock or personal injury:

- Do not apply more than the rated voltage, as marked on the calibrator, between the terminals, or between any terminal and earth ground (30 V 24 mA max all terminals).
- Before each use, verify the calibrator's operation by measuring a known voltage.
- Follow all equipment safety procedures.
- Never touch the probe to a voltage source when the test leads are plugged into the current terminals.
- Do not use the calibrator if it is damaged. Before you use the calibrator, inspect the case. Look for cracks or missing plastic. Pay particular attention to the insulation surrounding the connectors.
- Select the proper function and range for your measurement.
- Make sure the battery door is closed and latched before you operate the calibrator.
- Remove test leads from the calibrator before you open the battery door.
- Inspect the test leads for damaged insulation or exposed metal. Check test leads continuity. Replace damaged test leads before you use the calibrator.
- When using the probes, keep your fingers away from the probe contacts. Keep your fingers behind the finger guards on the probes.
- Connect the common test lead before you connect the live test lead. When you disconnect test leads, disconnect the live test lead first.
- Do not use the calibrator if it operates abnormally. Protection may be impaired. When in doubt, have the calibrator serviced.
- Do not operate the calibrator around explosive gas, vapor, or dust.

⚠ Warning

- When using a pressure module, make sure the process pressure line is shut off and depressurized before you connect it or disconnect it from the pressure module.
- Use only 4 AA batteries, properly installed in the calibrator case, to power the calibrator.
- Disconnect test leads before changing to another measure or source function.
- When servicing the calibrator, use only specified replacement parts.
- To avoid false readings, which could lead to possible electric shock or personal injury, replace the battery as soon as the battery indicator (➕) appears.

Caution

To avoid possible damage to calibrator or to equipment under test:

- Disconnect the power and discharge all high-voltage capacitors before testing resistance or continuity.
- Use the proper jacks, function, and range for your measurement or sourcing application.

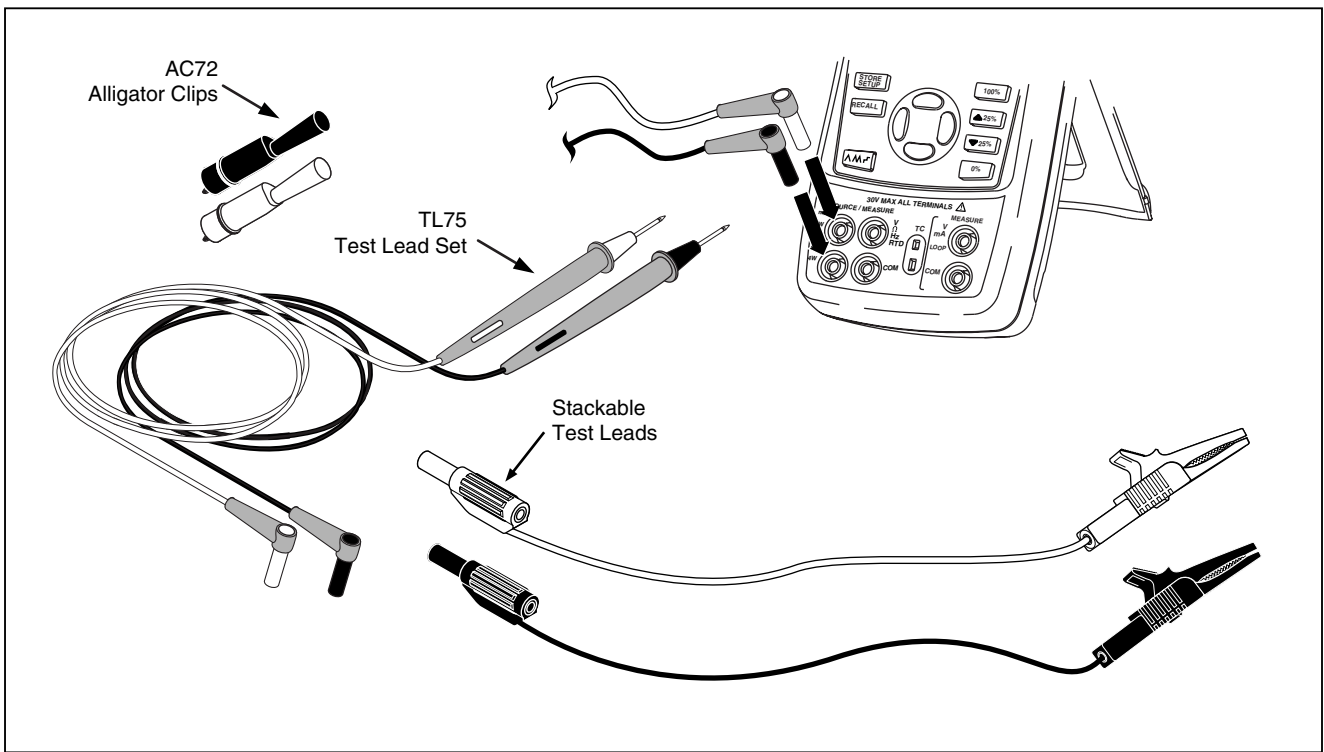











Figure 1. Standard Equipment

sh01f.eps

Table 2. International Symbols

	AC - Alternating current		Double insulated
	DC - Direct current		Battery
	Earth ground		Refer to the manual for information about this feature.
	Pressure		ON/OFF
	Conforms to Canadian Standards Association directives		Conforms to European Union directives

Getting Acquainted with the Calibrator

Input and Output Terminals

Figure 2 shows the calibrator input and output terminals. Table 3 explains their use.

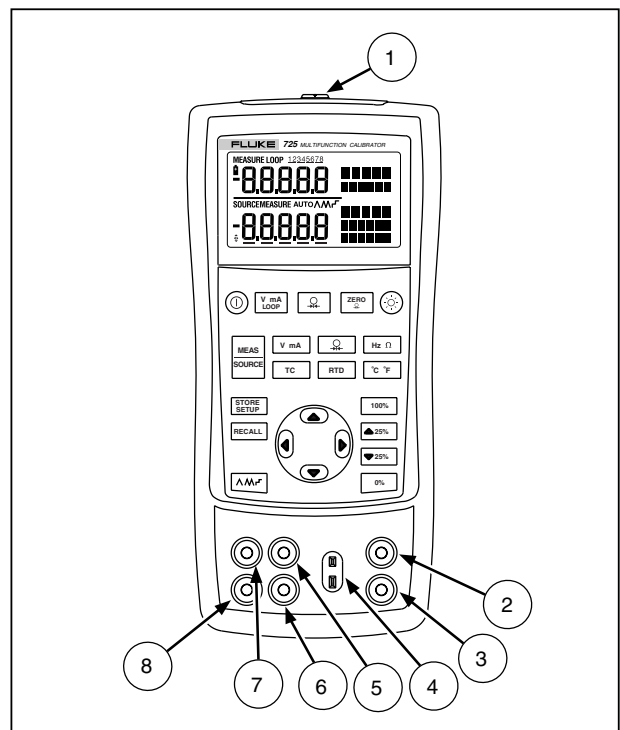

sh05f.eps
Figure 2. Input/Output Terminals and Connectors

Table 3. Input/Output Terminals and Connectors

No	Name	Description
①	Pressure module connector	Connects the calibrator to a pressure module or the calibrator to a PC for a remote control connection.
②, ③	MEASURE V, mA terminals	Input terminals for measuring voltage, current, and supplying loop power.
④	TC input/output	Terminal for measuring or simulating thermocouples. This terminal accepts a miniature polarized thermocouple plug with flat, in-line blades spaced 7.9 mm (0.312 in) center to center.
⑤, ⑥	SOURCE/ MEASURE V, RTD, Hz, Ω terminals	Terminals for sourcing or measuring voltage, resistance, frequency, and RTDs.
⑦, ⑧	SOURCE/ MEASURE mA terminals, 3W, 4W	Terminals for sourcing and measuring current, and performing 3W and 4W RTD measurements.

Keys

Figure 3 shows the calibrator keys and Table 4 explains their use.

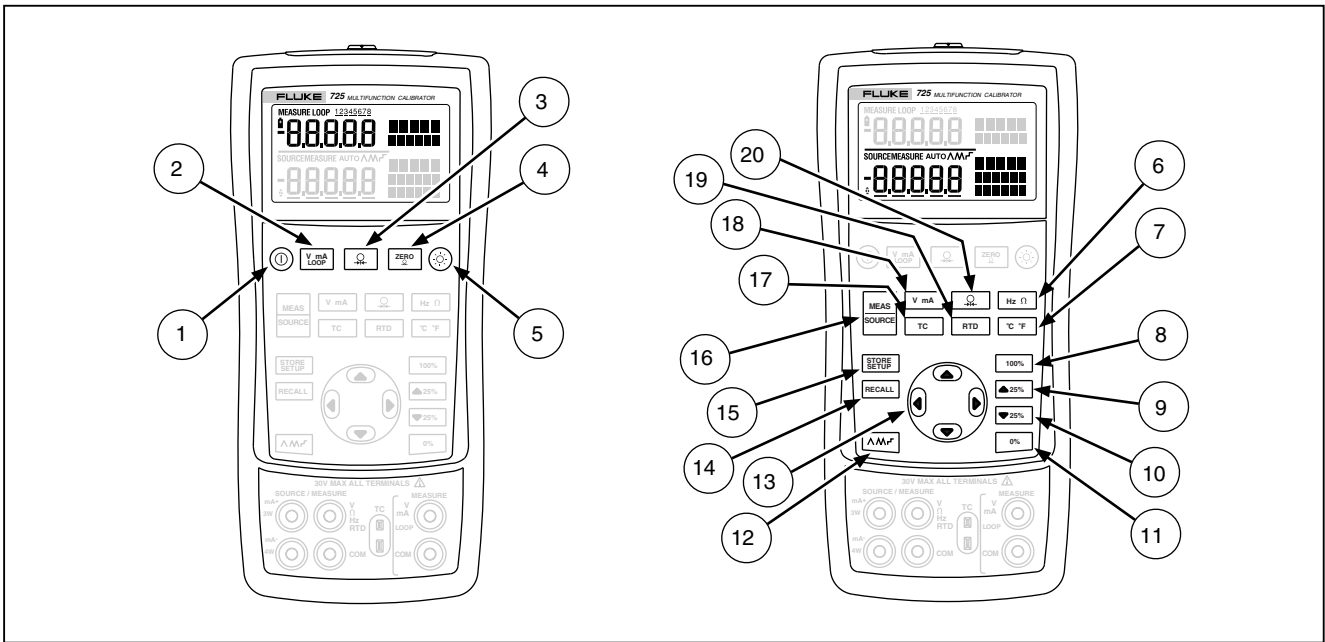

Figure 3. Keys

sh41f.eps

Table 4. Key Functions

























No	Name	Description
①		Turns the power on or off.
②		Selects voltage, mA or Loop Power measurement function in the upper display.
③		Selects the pressure measurement function in the upper display. Repeated pushes cycle through the different pressure units.
④		Zeros the pressure module reading. This applies to both upper and lower displays.
⑤		Turns backlight on or off. Turns Contrast Adjust mode on when powering up.
⑥		Toggles frequency and ohms measurement and sourcing functions.
⑦		Toggles between Centigrade or Fahrenheit when in TC or RTD functions.
⑧		Recalls from memory a source value corresponding to 100 % of span and sets it as the source value. Press and hold to store the source value as the 100 % value.
⑨		Increments output by 25 % of span.
⑩		Decrements output by 25 % of span.
⑪		Recalls from memory a source value corresponding to 0 % of span and sets it as the source value. Press and hold to store the source value as the 0 % value. Identifies Firmware version. Press and hold  when powering up.

Table 4. Key Functions (cont.)

No	Name	Description
⑫		Cycles through : \wedge Slow repeating 0 % - 100 % - 0 % ramp λ Fast repeating 0 % - 100 % - 0 % ramp \square Repeating 0 % - 100 % - 0 % ramp in 25 % steps
① ⑬		Disables Shut Down Mode
① ⑬		Enables Shut Down Mode
⑬	 	Increases or decreases the source level. Cycles through the 2-, 3-, and 4-wire selections. Moves through the memory locations of calibrator setups. In Contrast Adjustment mode; up-darkens contrast, down-lightens contrast.
⑭		Retrieves a previous calibrator setup from a memory location.
⑮		Saves the calibrator setup. Saves Contrast Adjust setup.
⑯		Cycles the calibrator through MEASURE and SOURCE modes in the lower display.
⑰		Selects TC (thermocouple) measurement and sourcing function in the lower display. Repeated pushes cycle through the thermocouple types.
⑱		Toggles between voltage, mA sourcing, or mA simulate functions in the lower display.
⑲		Selects RTD (resistance temperature detector) measurement and sourcing function in lower display. Repeated pushes cycle through the RTD types.
⑳		Selects the pressure measurement and sourcing function. Repeated pushes cycle through the different pressure units.

Display

Figure 4 shows the elements of a typical display.

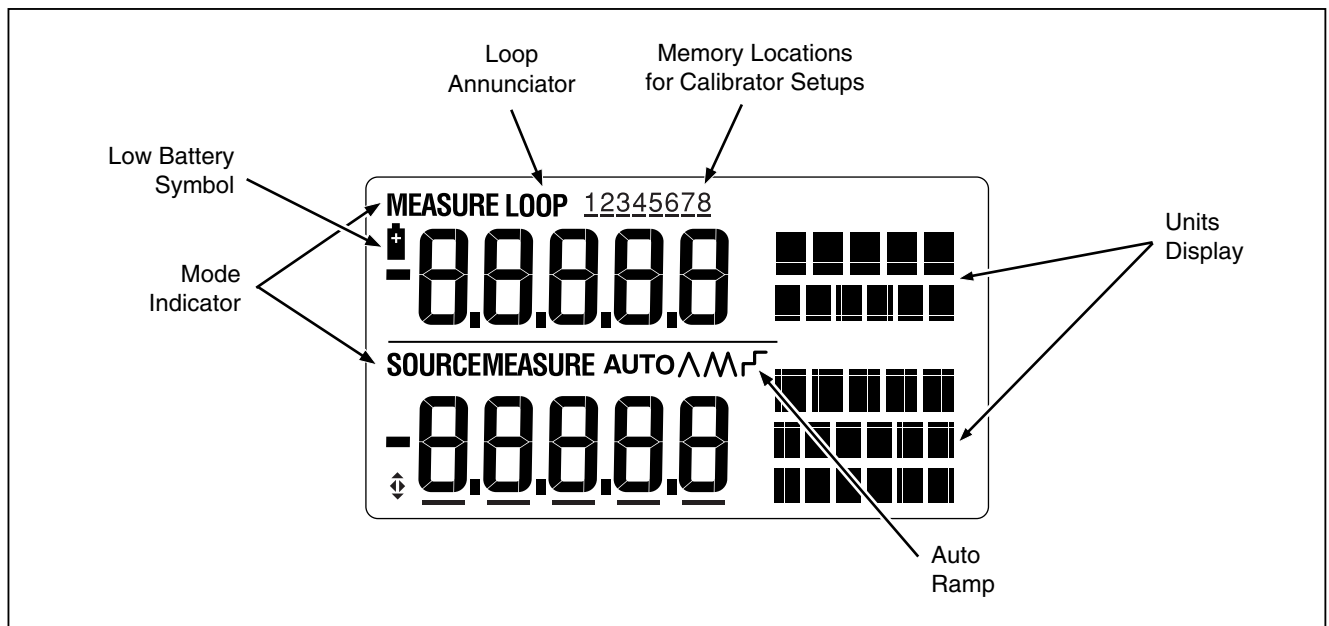









Figure 4. Elements of a Typical Display





sh07f.eps

Getting Started









This section acquaints you with some basic operations of the calibrator.

Proceed as follows to perform a voltage-to-voltage test:

1. Connect the calibrator's voltage output to its voltage input as shown in Figure 5.
2. Press  to turn on the calibrator. Press  to select dc voltage (upper display).
3. If necessary, press  for SOURCE mode (lower display). The calibrator is still measuring dc voltage, and you can see the active measurements in the upper display.
4. Press  to select dc voltage sourcing.
5. Press  and  to select a digit to change. Press  to select 1 V for the output value. Press and hold  to enter 1 V as the 0 % value.

6. Press  to increase the output to 5 V. Press and hold  to enter 5 V as the 100 % value.
7. Press  and  to step between 0 and 100 % in 25 % step increments.

Shut Down Mode

The calibrator comes with the Shut Down mode enabled for a time duration set to 30 minutes (displayed for about 1 second when the calibrator is initially turned on). When the Shut Down mode is enabled, the calibrator will automatically shut down after the time duration has elapsed from the time the last key was pressed. To disable the Shut Down mode, press  and  simultaneously. To enable the mode, press  and  simultaneously. To adjust the time duration, press  and  simultaneously, then press  and/or  to adjust the time between 1 and 30 minutes.

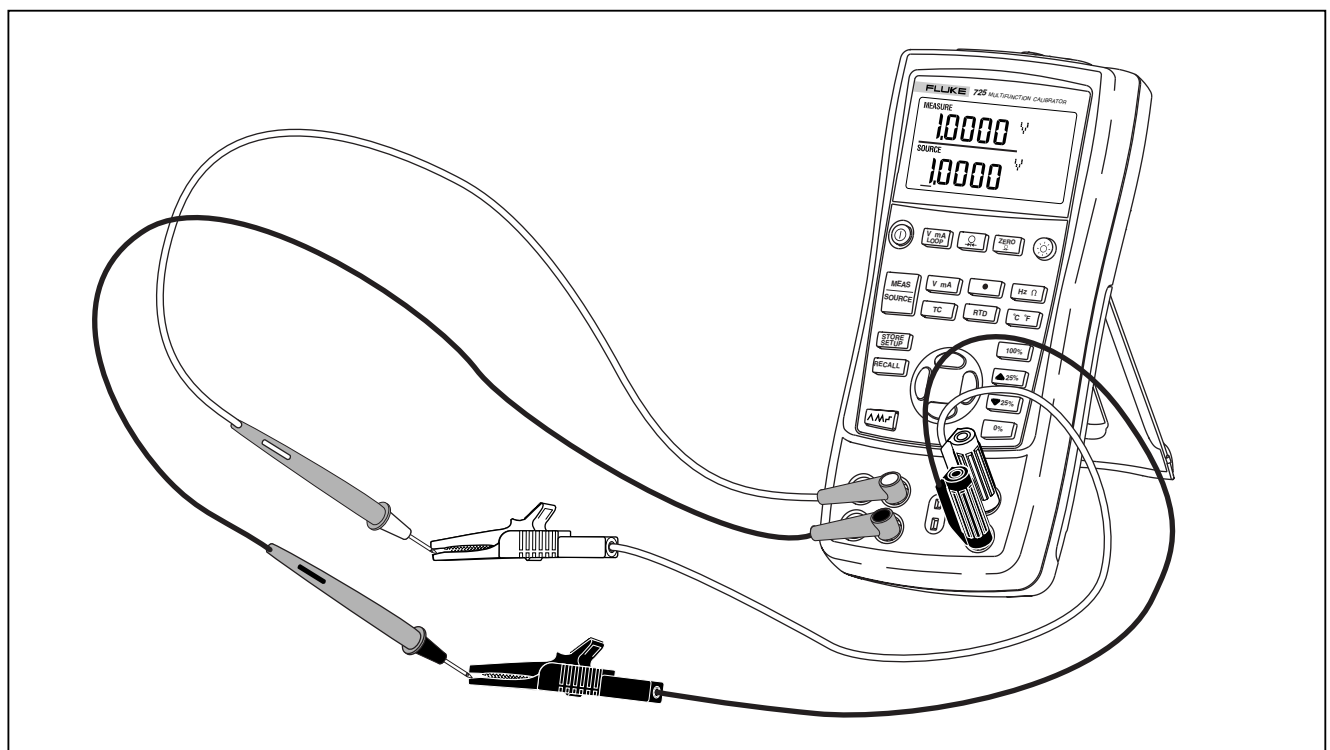

sh39f.eps





Figure 5. Voltage-to-Voltage Test

Contrast Adjustment

Note

Available with V2.1 Firmware or greater. To identify firmware version, press and hold  when powering up. The firmware version will be shown in the upper units display for about 1 second after initialization.

To adjust the contrast, proceed as follows:

1. Press  and  until Contst Adjust is displayed as shown in Figure 6.
2. Press and hold  to darken contrast.
3. Press and hold  to lighten contrast.
4. Press  to save the contrast level.

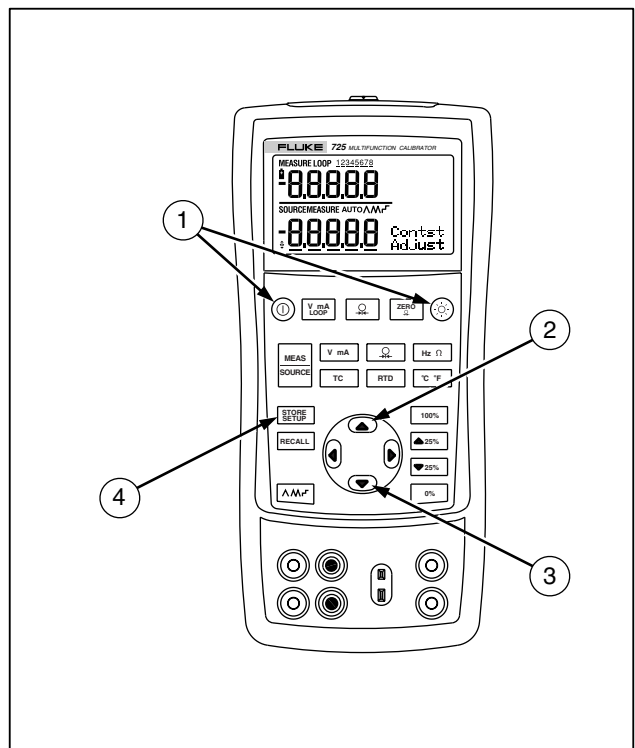

Figure 6. Adjusting the Contrast

sh06f.eps

Using Measure Mode

Measuring Electrical Parameters (Upper Display)

To measure the current or voltage output of a transmitter, or to measure the output of a pressure instrument, use the upper display and proceed as follows:

1. Press $\left[\begin{array}{c} \text{V mA} \\ \text{LOOP} \end{array} \right]$ to select volts or current. LOOP should not be on.
2. Connect the leads as shown in Figure 7.

Current Measurement with Loop Power

The loop power function activates a 24 V supply in series with the current measuring circuit, allowing you to test a transmitter when it is disconnected from plant wiring. To measure current with loop power, proceed as follows:

1. Connect the calibrator to the transmitter current loop terminals as shown in Figure 8.
2. Press $\left[\begin{array}{c} \text{V mA} \\ \text{LOOP} \end{array} \right]$ while the calibrator is in current measurement mode. LOOP appears and an internal 24 V loop supply turns on.

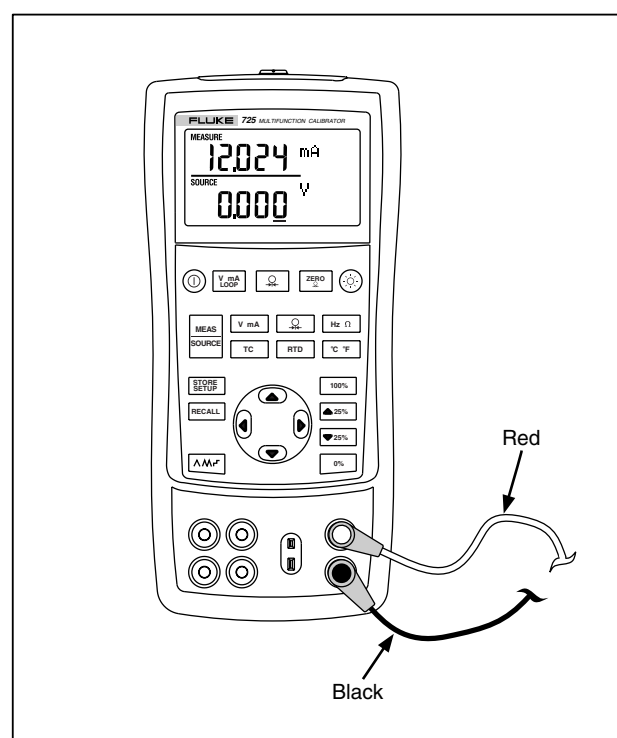

Figure 7. Measuring Voltage and Current Output

sh42f.eps

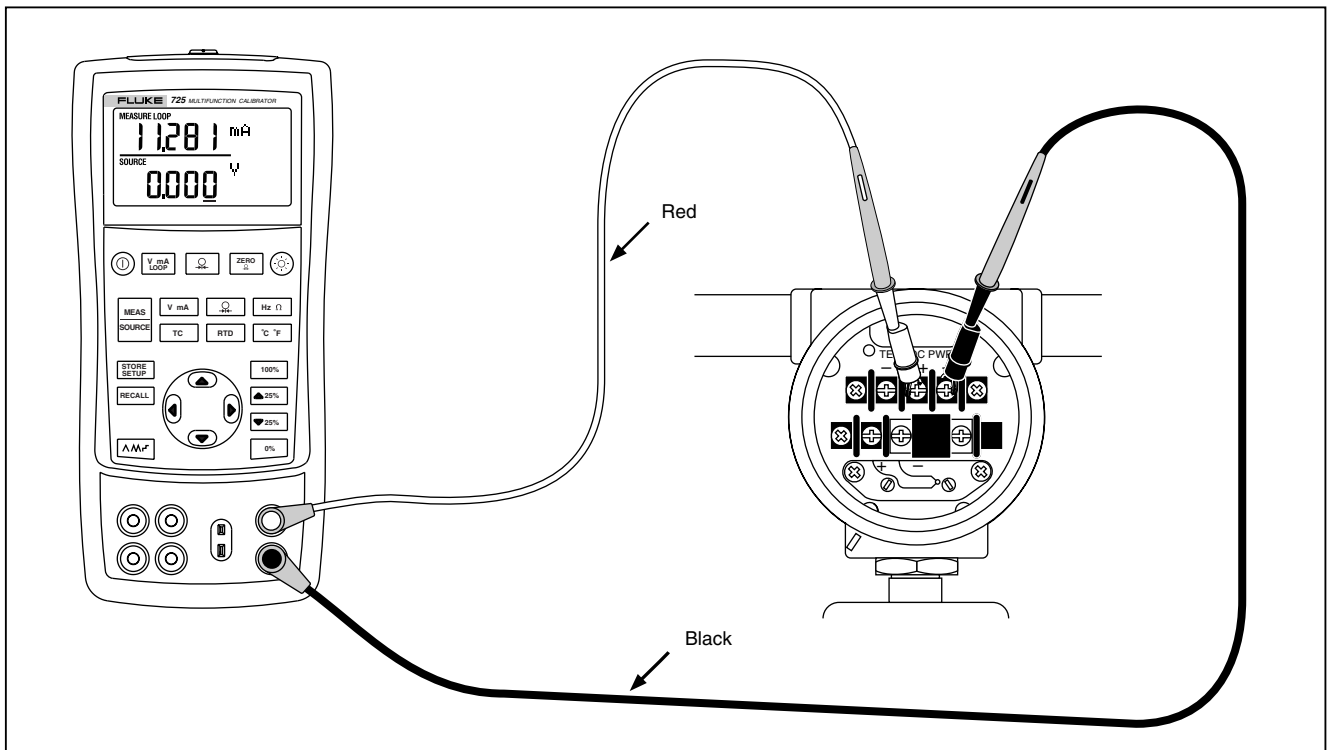





Figure 8. Connections for Supplying Loop Power

sh18f.eps

Measuring Electrical Parameters (Lower Display)

To measure the electrical parameters using the lower display, proceed as follows:

1. Connect the calibrator as shown in Figure 9.
2. If necessary, press  for MEASURE mode (lower display)
3. Press  for dc voltage or current, or  for frequency or resistance.

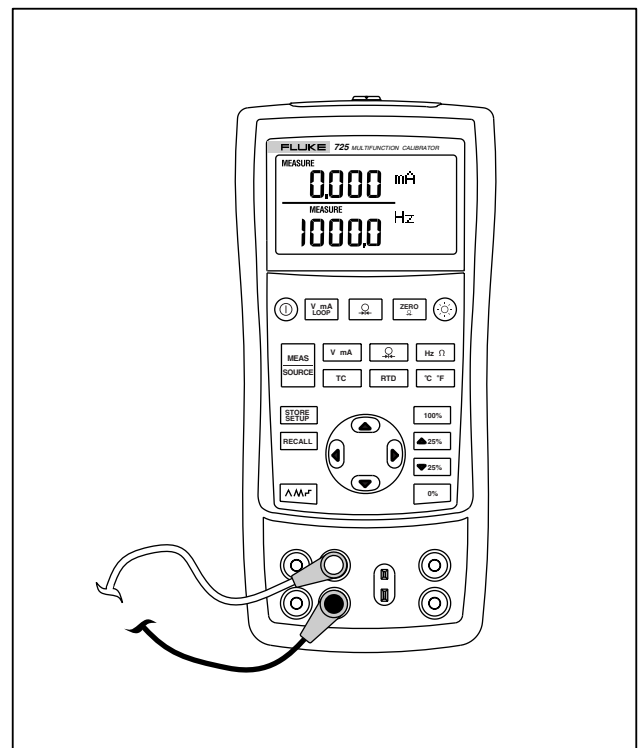

sh43f.eps

Figure 9. Measuring Electrical Parameters

Measuring Temperature

Using Thermocouples



The calibrator supports ten standard thermocouples, including type E, N, J, K, T, B, R, S, L, or U. Table 5 summarizes the ranges and characteristics of the supported thermocouples.

To measure temperature using a thermocouple, proceed as follows:

1. Attach the thermocouple leads to the appropriate TC miniplug, then to the TC input/output as shown in Figure 10. *One pin is wider than the other. Do not try to force a miniplug in the wrong polarization.*

Note

If the calibrator and the thermocouple plug are at different temperatures, wait one minute or more for the connector temperature to stabilize after you plug the miniplug into the TC input/output.

2. If necessary, press  for MEASURE mode.
3. Press  for the TC display. If desired, continue pressing this key to select the desired thermocouple type.

If necessary, you can toggle between °C or °F temperature units by pressing .

Table 5. Thermocouple Types Accepted

Type	Positive Lead Material	Positive Lead (H) Color		Negative Lead Material	Specified Range (°C)
		ANSI*	IEC**		
E	Chromel	Purple	Violet	Constantan	-200 to 950
N	Ni-Cr-Si	Orange	Pink	Ni-Si-Mg	-200 to 1300
J	Iron	White	Black	Constantan	-200 to 1200
K	Chromel	Yellow	Green	Alumel	-200 to 1370
T	Copper	Blue	Brown	Constantan	-200 to 400
B	Platinum (30 % Rhodium)	Gray		Platinum (6 % Rhodium)	600 to 1800
R	Platinum (13 % Rhodium)	Black	Orange	Platinum	-20 to 1750
S	Platinum (10 % Rhodium)	Black	Orange	Platinum	-20 to 1750
L	Iron			Constantan	-200 to 900
U	Copper			Constantan	-200 to 400
*American National Standards Institute (ANSI) device negative lead (L) is always red.					
**International Electrotechnical Commission (IEC) device negative lead (L) is always white.					

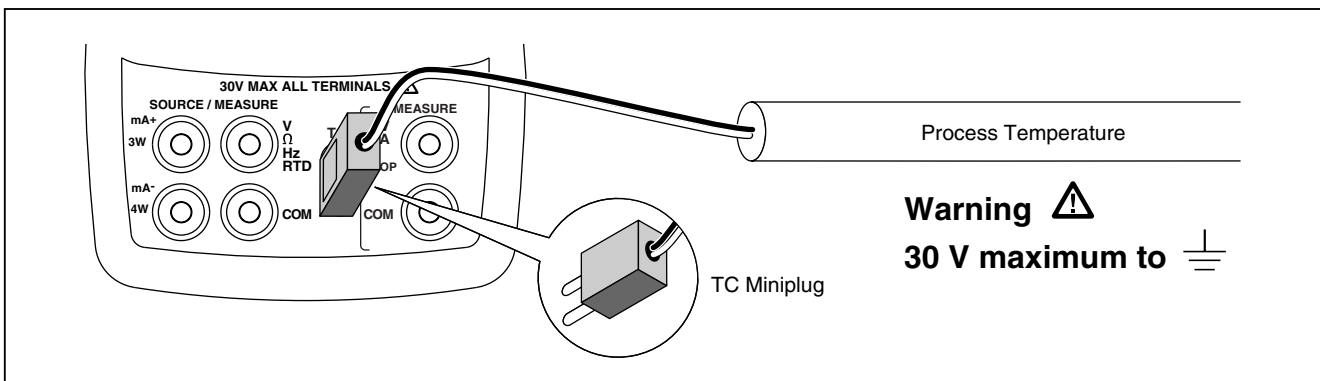

Figure 10. Measuring Temperature with a Thermocouple

sh12f.eps

Using Resistance-Temperature Detectors (RTDs)

The calibrator accepts RTD types shown in Table 6. RTDs are characterized by their resistance at 0 °C (32 °F), which is called the “ice point” or R_0 . The most common R_0 is 100 Ω . The calibrator accepts RTD measurement inputs in two-, three-, or four-wire connections, with the three-wire connection the most common. A four-wire configuration provides the highest measurement precision, and two-wire provides the lowest measurement precision.

To measure temperature using an RTD input, proceed as follows:





1. If necessary, press  for MEASURE mode.
2. Press  for the RTD display. If desired, continue pressing this key to select the desired RTD type.
3. Press  or  to select a 2-, 3-, or 4- wire connection.
4. Attach the RTD to input terminals as shown in Figure 11.
5. If necessary, you can toggle between °C or °F temperature units by pressing .

Table 6. RTD Types Accepted

RTD Type	Ice Point (R_0)	Material	α	Range ($^{\circ}\text{C}$)
Pt100 (3926)	100 Ω	Platinum	0.003926 $\Omega/^{\circ}\text{C}$	-200 to 630
Pt100 (385)	100 Ω	Platinum	0.00385 $\Omega/^{\circ}\text{C}$	-200 to 800
Ni120 (672)	120 Ω	Nickel	0.00672 $\Omega/^{\circ}\text{C}$	-80 to 260
Pt200 (385)	200 Ω	Platinum	0.00385 $\Omega/^{\circ}\text{C}$	-200 to 630
Pt500 (385)	500 Ω	Platinum	0.00385 $\Omega/^{\circ}\text{C}$	-200 to 630
Pt1000 (385)	1000 Ω	Platinum	0.00385 $\Omega/^{\circ}\text{C}$	-200 to 630
Pt100 (3916)	100 Ω	Platinum	0.003916 $\Omega/^{\circ}\text{C}$	-200 to 630

The Pt100 commonly used in U.S. industrial applications is Pt100 (3916), $\alpha = 0.003916 \Omega/^{\circ}\text{C}$. (Also designated as JIS curve.) The IEC standard RTD is the Pt100 (385), $\alpha = 0.00385 \Omega/^{\circ}\text{C}$.

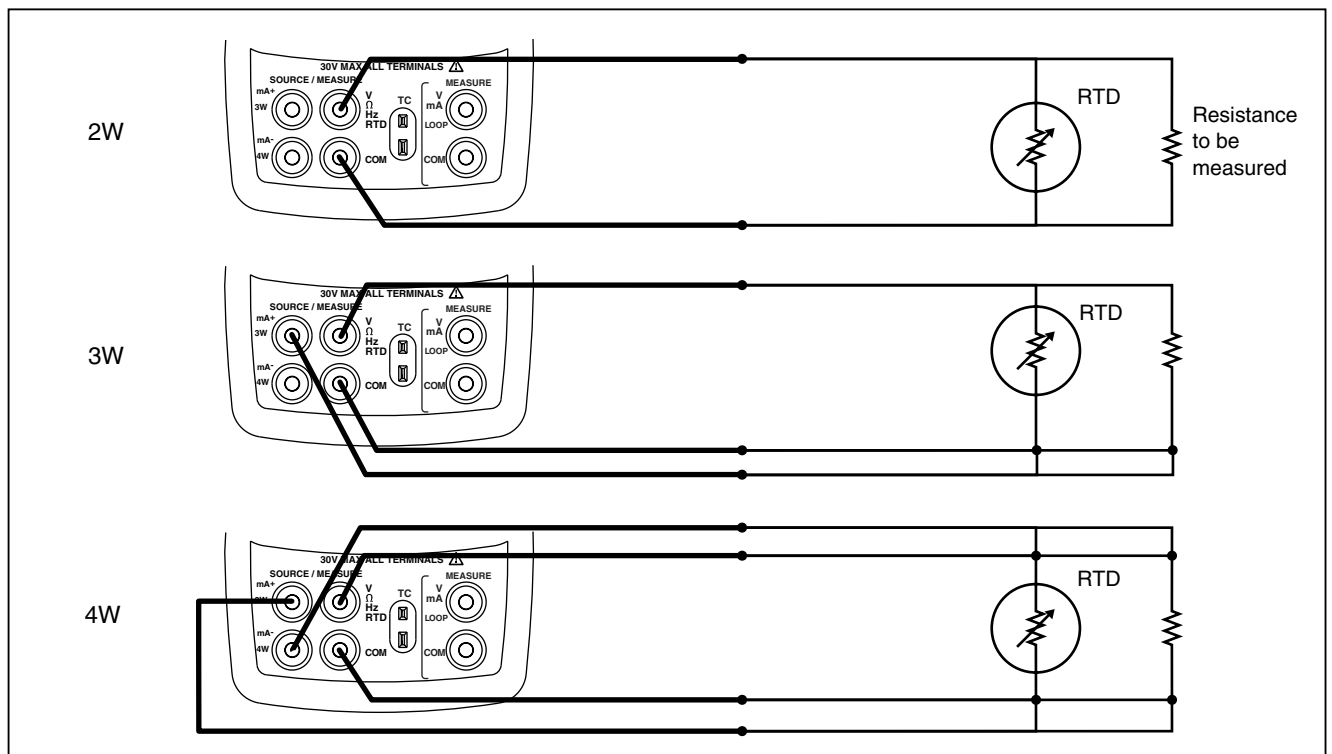

Figure 11. Measuring Temperature with an RTD, Measuring 2-, 3-, and 4-Wire Resistance

sh15f.eps

Measuring Pressure

Many ranges and types of pressure modules are available from Fluke. See “Accessories” near the back of this manual. Before you use a pressure module, read its instruction sheet. The modules vary in use, media, and accuracy.

Figure 12 shows the gage and differential modules. Differential modules also work in gage mode by leaving the low fitting open to atmosphere.

To measure pressure, attach the appropriate pressure module for the process pressure to be tested

Proceed as follows to measure pressure:

⚠ Warning

To avoid a violent release of pressure in a pressurized system, shut off the valve and slowly bleed off the pressure before you attach the pressure module to the pressure line.

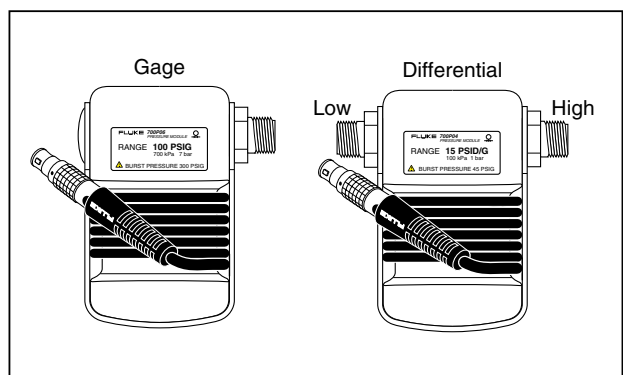

gj11f.eps



Figure 12. Gage and Differential Pressure Modules

Caution

To avoid mechanically damaging the pressure module, never apply more than 10 ft.-lb. (13.5 Nm) of torque between the pressure module fittings, or between the fittings and the body of the module. Always apply appropriate torque between the pressure module fitting and connecting fittings or adapters.

To avoid damaging the pressure module from overpressure, never apply pressure above the rated maximum printed on the pressure module.

To avoid damaging the pressure module from corrosion, use it only with specified materials. Refer to the printing on the pressure module or the pressure module instruction sheet for the acceptable material compatibility.





1. Connect a pressure module to the calibrator as shown in Figure 13. The threads on the pressure modules accept standard ¼ NPT pipe fittings. Use the supplied ¼ NPT to ¼ ISO adapter if necessary.
2. Press . The calibrator automatically senses which pressure module is attached and sets its range accordingly.
3. Zero the pressure module as described in the module's Instruction Sheet. Modules vary in zeroing procedures depending on module type, but all require pressing .

If desired, continue pressing  to change pressure display units to psi, mmHg, inHg, cmH₂O@4 °C,

cmH₂O@20 °C, inH₂O@4 °C, inH₂O@20 °C, mbar, bar, kg/cm², or kPa.

Zeroing with Absolute Pressure Modules

To zero, adjust the calibrator to read a known pressure. This can be barometric pressure, if it is accurately known, for all but the 700PA3 module. The maximum range of 700PA3 is 5 psi; therefore the reference pressure must be applied with a vacuum pump. An accurate pressure standard can also apply a pressure within range for any absolute pressure module. To adjust the calibrator reading, proceed as follows:

1. Press , REF Adjust will appear to the right of the pressure reading.
2. Use  to increase or  to decrease the calibrator reading to equal the reference pressure.
3. Press  again to exit zeroing procedure.

The calibrator stores and automatically reuses the zero offset correction for one absolute pressure module so that the module is not rezeroed every time you use it.

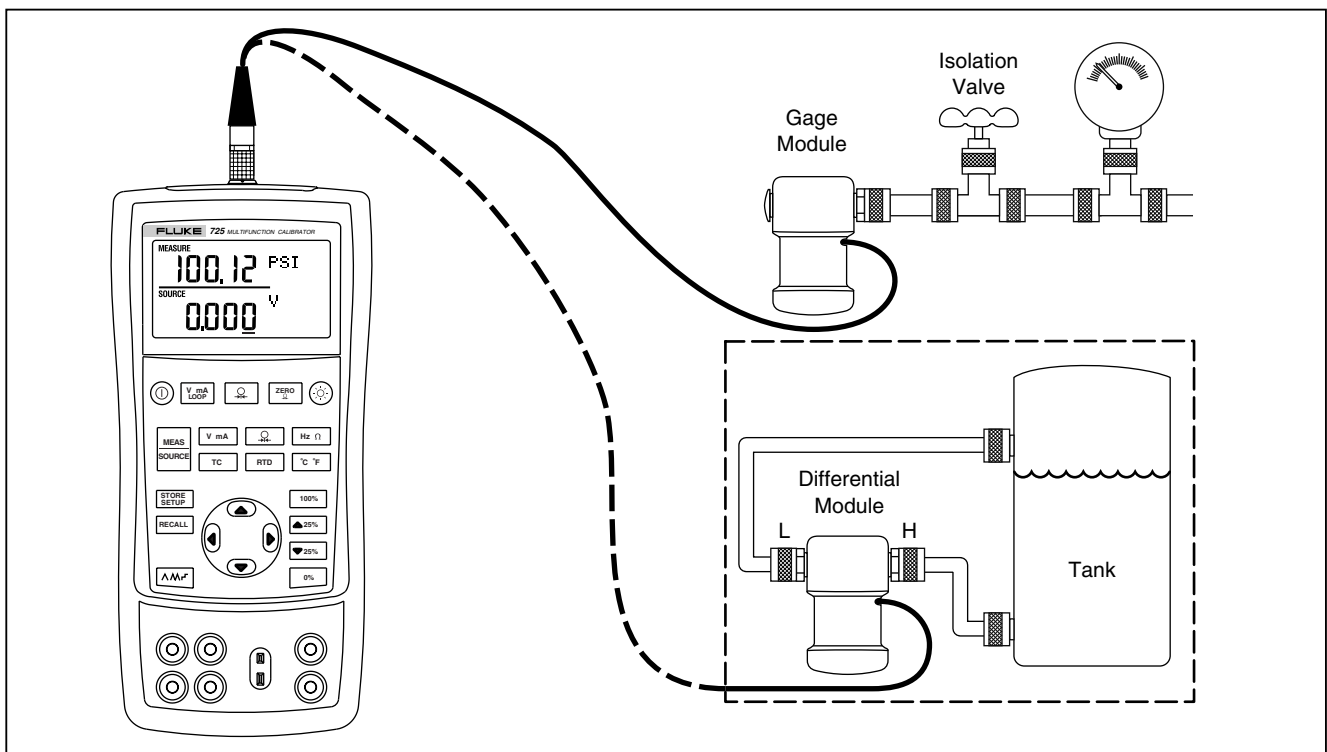

Figure 13. Connections for Measuring Pressure





sh371.eps

Using Source Mode

In SOURCE mode, the calibrator generates calibrated signals for testing and calibrating process instruments; supplies voltages, currents, frequencies, and resistances; simulates the electrical output of RTD and thermocouple temperature sensors; and measures gas pressure from an external source, creating a calibrated pressure source.

Sourcing 4 to 20 mA





To select the current sourcing mode, proceed as follows:

1. Connect the test leads in the mA terminals (left column).
2. If necessary, press  for SOURCE mode.
3. Press  for current and enter the desired current you want by pressing  and  keys.

Simulating a 4- to 20-mA Transmitter

Simulate is a special mode of operation in which the calibrator is connected into a loop in place of a transmitter and supplies a known, settable test current. Proceed as follows:







1. Connect the 24 V loop power source as shown in Figure 14.

2. If necessary, press  for SOURCE mode.
3. Press  until both mA and SIM display.
4. Enter the desired current by pressing  and  keys.

Sourcing Other Electrical Parameters

Volts, ohms, and frequency are also sourced and shown in the lower display.

To select an electrical sourcing function, proceed as follows:

1. Connect the test leads as shown in Figure 15, depending on the source function.
2. If necessary, press  for SOURCE mode.
3. Press  for dc voltage, or  for frequency or resistance.
4. Enter the desired output value by pressing  and  keys. Press  and  to select a different digit to change.

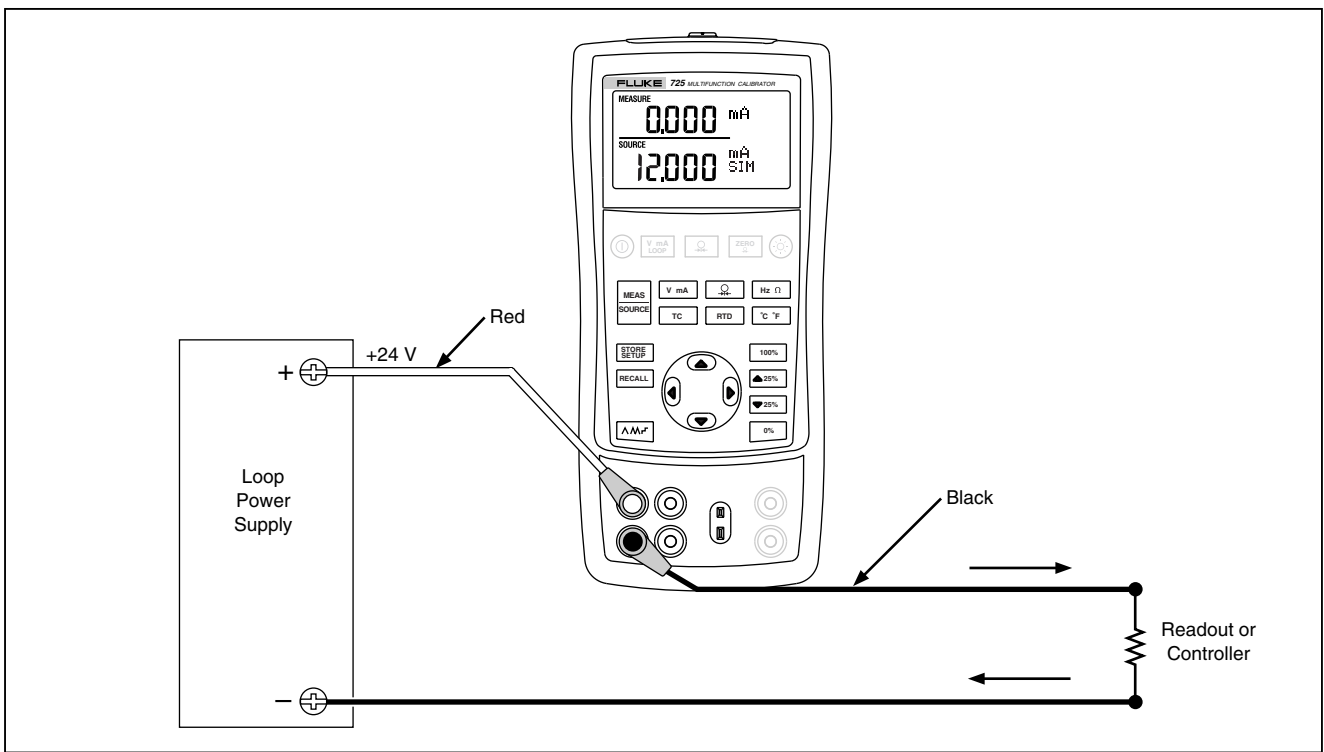

Figure 14. Connections for Simulating a 4- to 20-mA Transmitter

sh17f.eps

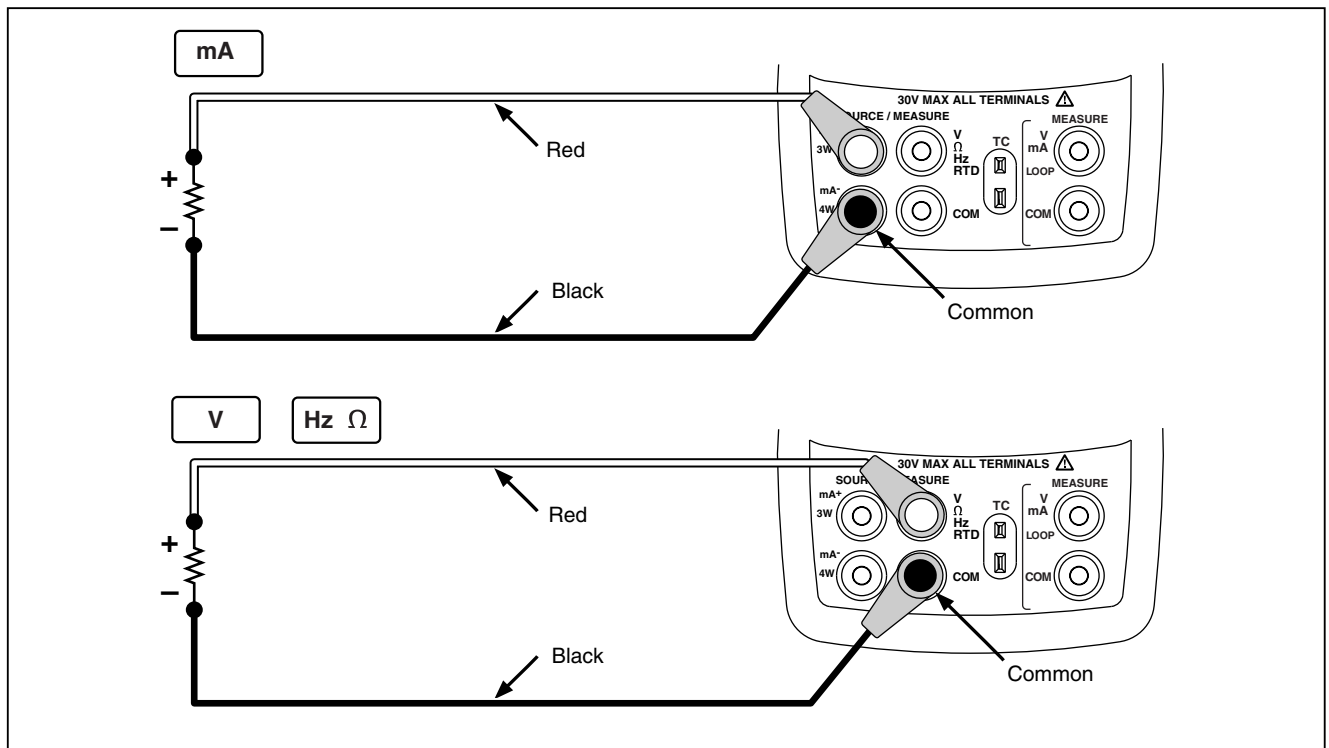







Figure 15. Electrical Sourcing Connections

sh16f.eps

Simulating Thermocouples

Connect the calibrator TC input/output to the instrument under test with thermocouple wire and the appropriate thermocouple mini-connector (polarized thermocouple plug with flat, in-line blades spaced 7.9 mm [0.312 in] center to center). *One pin is wider than the other. Do not try to force a miniplug in the wrong polarization.* Figure 16 shows this connection. Proceed as follows to simulate a thermocouple:

1. Attach the thermocouple leads to the appropriate TC miniplug, then to the TC input/output as shown in Figure 16.
2. If necessary, press  for SOURCE mode.
3. Press  for the TC display. If desired, continue pressing this key to select the desired thermocouple type.
4. Enter the temperature you want by pressing  and  keys. Press  and  to select a different digit to edit.





Simulating RTDs

Connect the calibrator to the instrument under test as shown in Figure 17. Proceed as follows to simulate an RTD:

1. If necessary, press  for SOURCE mode.
2. Press  for the RTD display.

Note

Use the 3W and 4W terminals for measurement only, not for simulation. The calibrator simulates a 2-wire RTD at its front panel. To connect to a 3-wire or 4-wire transmitter, use the stacking cables to provide the extra wires. See Figure 17.

3. Enter the temperature you want by pressing  and  keys. Press  and  to select a different digit to edit.
4. If the 725 display indicates ExI HI, the excitation current from your device under test exceeds the limits of the 725.

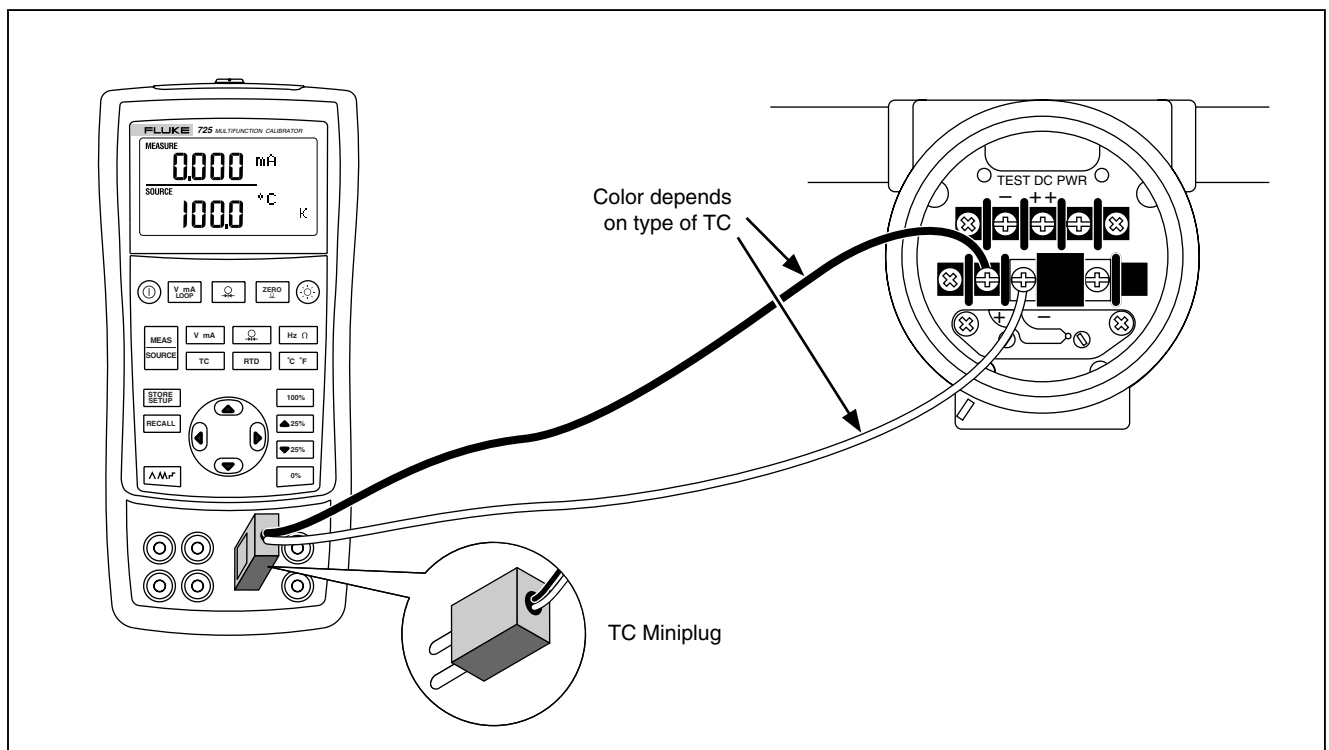

Figure 16. Connections for Simulating a Thermocouple

sh20f.eps

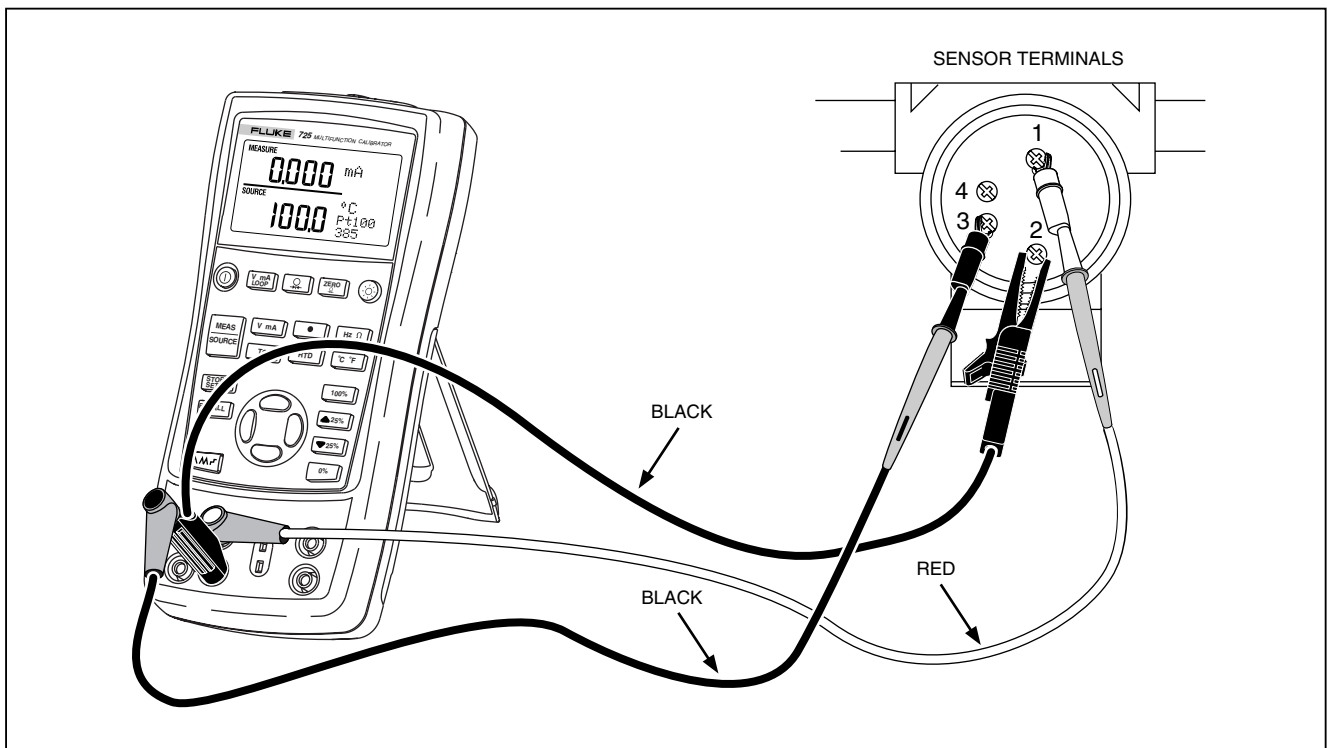

Figure 17. Connections for Simulating 3-Wire RTD

sh40f.eps

Sourcing Pressure

The calibrator sources pressure by measuring pressure supplied by a pump or other sources, and displaying the pressure in the SOURCE field. Figure 20 shows how to connect a pump to a Fluke pressure module which makes it a calibrated source.

Many ranges and types of pressure modules are available from Fluke. See “Accessories” near the back of this manual. Before you use a pressure module, read its Instruction Sheet. The modules vary in use, media, and accuracy.

Attach the appropriate pressure module for the process pressure to be tested.

Proceed as follows to source pressure:

⚠ Warning

To avoid a violent release of pressure in a pressurized system, shut off the valve and slowly bleed off the pressure before you attach the pressure module to the pressure line.

Caution

To avoid mechanically damaging the pressure module, never apply more than 10 ft.-lb. (13.5 Nm) of torque between the pressure module fittings, or between the fittings and the body of the module. Always apply appropriate torque between the pressure module fitting and connecting fittings or adapters.

To avoid damaging the pressure module from overpressure, never apply pressure above the rated maximum printed on the pressure module.

To avoid damaging the pressure module from corrosion, use it only with specified materials. Refer to the printing on the pressure module or the pressure module instruction sheet for the acceptable material compatibility.

725

Users Manual

1. Connect a pressure module to the calibrator as shown in Figure 18. The threads on the pressure modules accept standard ¼ NPT pipe fittings. Use the supplied ¼ NPT to ¼ ISO adapter if necessary.
2. Press  (lower display). The calibrator automatically senses which pressure module is attached and sets its range accordingly.
3. Zero the pressure module as described in the module's Instruction Sheet. Modules vary in zeroing procedures depending on module type.
4. Pressurize the pressure line with the pressure source to the desired level as shown on the display.

If desired, continue pressing  to change pressure display units to psi, mmHg, inHg, cmH₂O@4 °C, cmH₂O@20 °C, inH₂O@4 °C, inH₂O@20 °C, mbar, bar, kg/cm², or kPa.

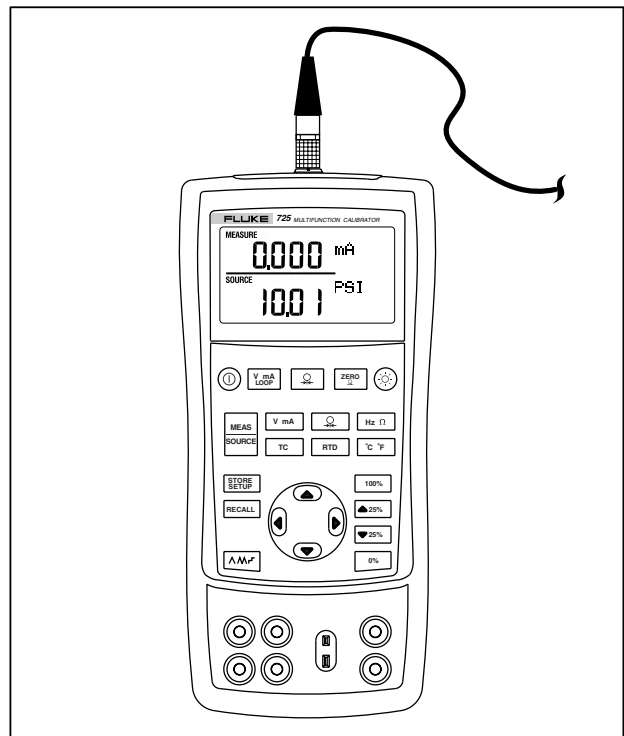



sh19f.eps



Figure 18. Connections for Sourcing Pressure

Setting 0 % and 100 % Output Parameters

For current output, the calibrator assumes that 0 % corresponds to 4 mA and 100 % corresponds to 20 mA. For other output parameters, you must set the 0 % and 100 % points before you can use the step and ramp functions. Proceed as follows:



1. If necessary, press  for SOURCE mode.
2. Select the desired source function and use the arrow keys to enter the value. Our example is temperature source using 100 °C and 300 °C values for source.
3. Enter 100 °C and press and hold  to store the value.
4. Enter in 300 °C and press and hold  to store the value.

You can now use this setting for the following:

- Manually stepping an output with 25 % increments.
- Jump between the 0 and 100 % span points by momentarily pushing  or .

Stepping and Ramping the Output





Two features are available for adjusting the value of source functions.

- Stepping the output manually with the  and  keys, or in automatic mode.
- Ramping the output.

Stepping and ramping apply to all functions except pressure, which requires that you use an external pressure source.

Manually Stepping the mA Output



To manually step current output you can do the following:

- Use  or  to step the current up or down in 25 % steps.
- Touch momentarily either  to go to 0 %, or  to go to 100 %.

Auto Ramping the Output

Auto ramping gives you the ability to continuously apply a varying stimulus from the calibrator to a transmitter, while your hands remain free to test the response of the transmitter.

When you press , the calibrator produces a continuously repeating 0 % - 100 % - 0 % ramp in your choice of three ramp waveforms:

-  0 % - 100 % - 0 % 40-second smooth ramp
-  0 % - 100 % - 0 % 15-second smooth ramp
-  0 % - 100 % - 0 % Stair-step ramp in 25 % steps, pausing 5 seconds at each step. Steps are listed in Table 7.





To exit ramping, press any button.

Table 7. mA Step Values





Step	4 to 20 mA
0 %	4.000
25 %	8.000
50 %	12.000
75 %	16.000
100 %	20.000

Storing and Recalling Setups

You can store up to eight of your settings in a nonvolatile memory and recall the settings for later use. A low battery condition or a battery change does not jeopardize the stored settings. Proceed as follows:

1. After you create a calibrator setup, press . In the display, the memory locations appear.
2. Press  or  to select locations one through eight. An underscore appears below the selected memory location.
3. Press , only the stored memory location will be displayed. The setup is stored.











To recall setups, proceed as follows.

1. Press . The memory locations appear on the display.
2. Press  or  to select the appropriate location and press .

Calibrating a Transmitter

Use the measurement (upper display) and source (lower display) modes to calibrate a transmitter. This section applies to all but pressure transmitters. The following example shows how to calibrate a temperature transmitter.

Connect the calibrator to the instrument under test as shown in Figure 19. Proceed as follows to calibrate a transmitter

1. Press  for current (upper display). If required, press  again to activate loop power.
2. Press  (lower display). If desired, continue pressing this key to select the desired thermocouple type.
3. If necessary, press  for SOURCE mode.
4. Set your zero and span parameters by pressing  and  keys. Enter these parameters by pressing and holding  and . For more information on setting parameters, see “Setting 0 % and 100 %” earlier in this manual.
5. Perform test checks at 0-25-50-75-100 % points by pressing  or . Adjust the transmitter as necessary.

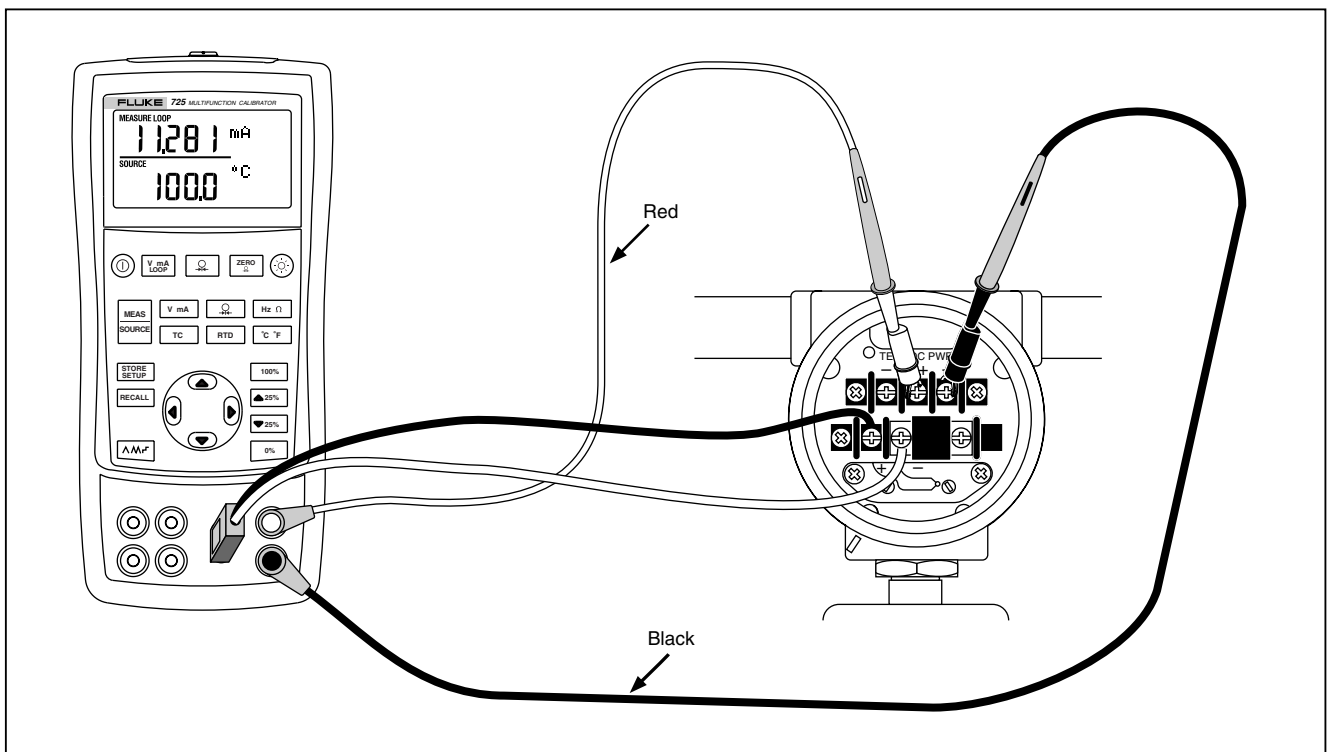





sh44f.eps

Figure 19. Calibrating a Thermocouple Transmitter

Calibrating a Pressure Transmitter

The following example shows how to calibrate a pressure transmitter.

Connect the calibrator to the instrument under test as shown in Figure 20. Proceed as follows:

1. Press  for current (upper display). If required, press  again to activate loop power.
2. Press  (lower display).
3. If necessary, press  for SOURCE mode.
4. Zero the pressure module.
5. Perform checks at 0 % and 100 % of span and adjust the transmitter as necessary.

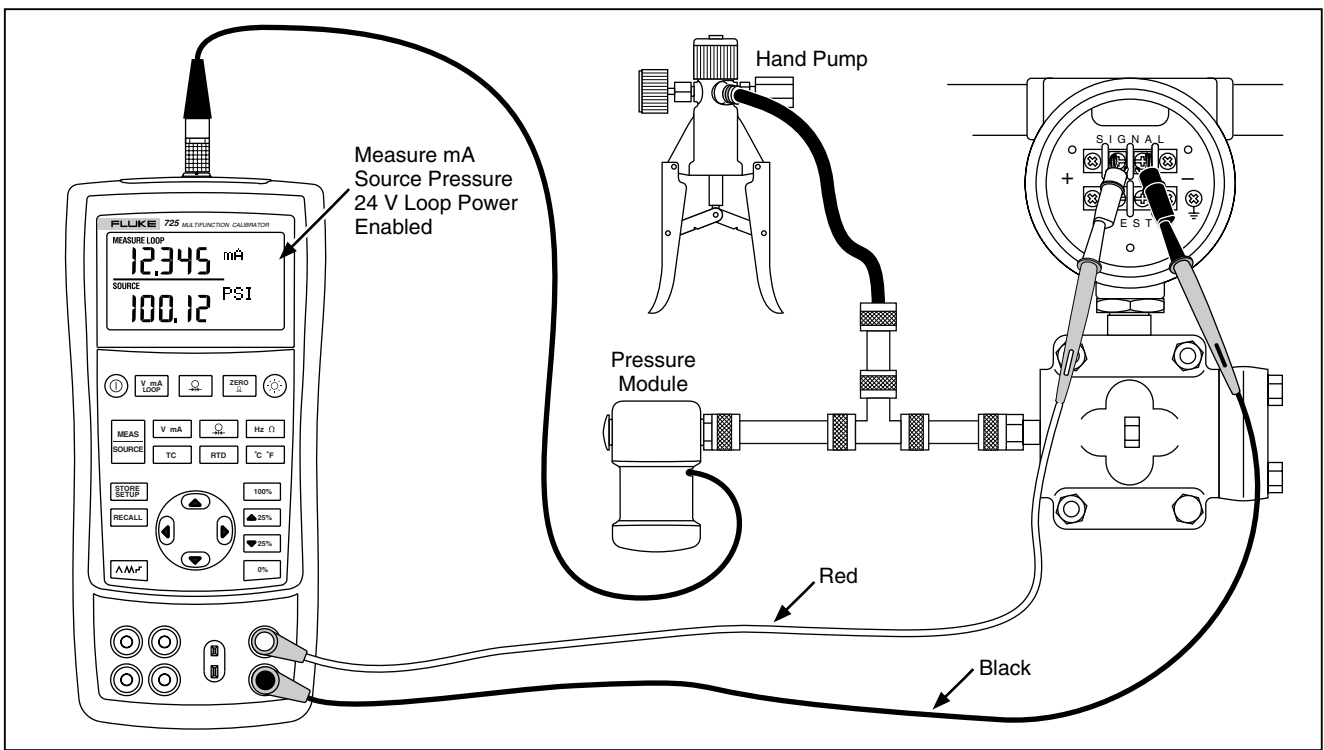









Figure 20. Calibrating a Pressure-to-Current (P/I) Transmitter

sh34f.eps

Calibrating an I/P Device

The following test allows you to calibrate a device that controls pressure. Proceed as follows:

1. Connect the test leads to the instrument under test as shown in Figure 21. The connections simulate a current-to-pressure transmitter and measures the corresponding output pressure.
2. Press  (upper display).
3. Press  for sourcing current (lower display).
4. If necessary, press  for SOURCE mode.
5. Enter the desired current by pressing  and  keys. Press  and  to select different digits.

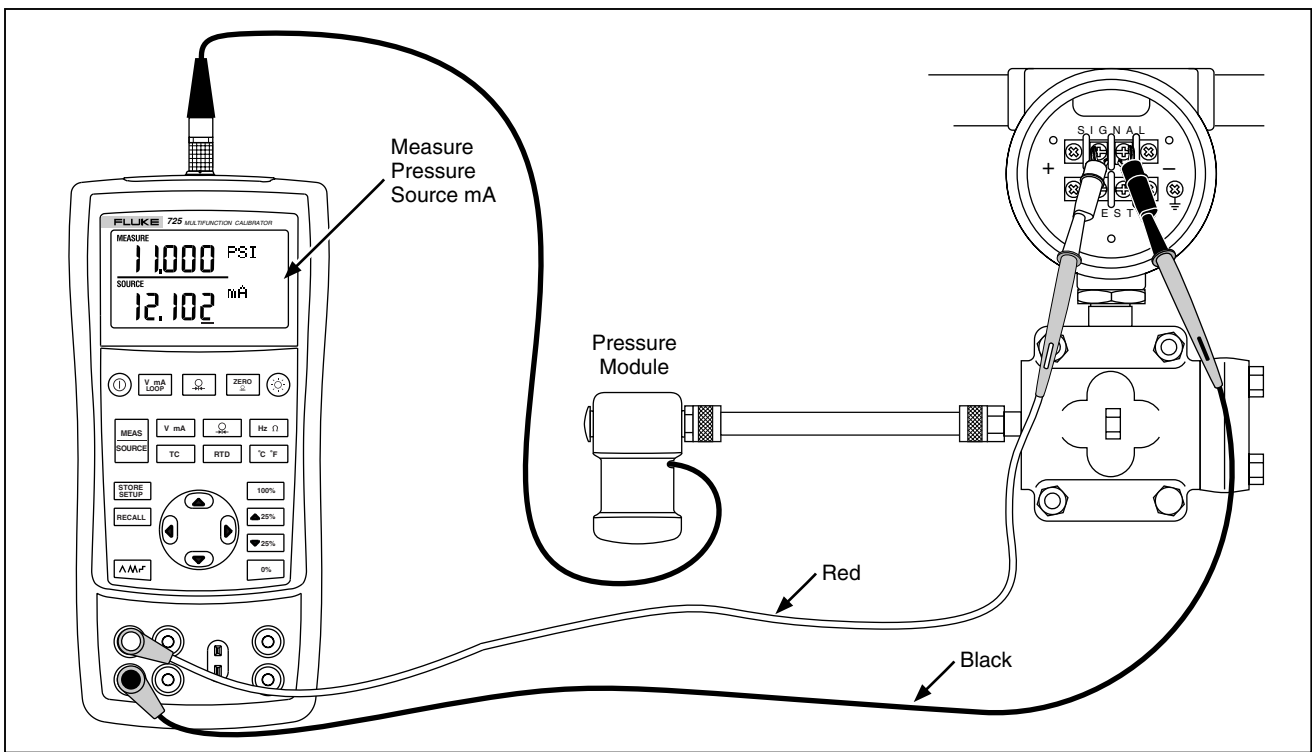

Figure 21. Calibrating a Current-to-Pressure (I/P) Transmitter

sh28f.eps

Testing an Output Device

Use the source functions to test and calibrate actuators, recording, and indicating devices. Proceed as follows:

1. Connect the test leads to the instrument under test as shown in Figure 22.
2. Press V mA for current or dc voltage, or $\text{Hz } \Omega$ for frequency or resistance (lower display).
3. If necessary, press MEAS SOURCE for SOURCE mode.

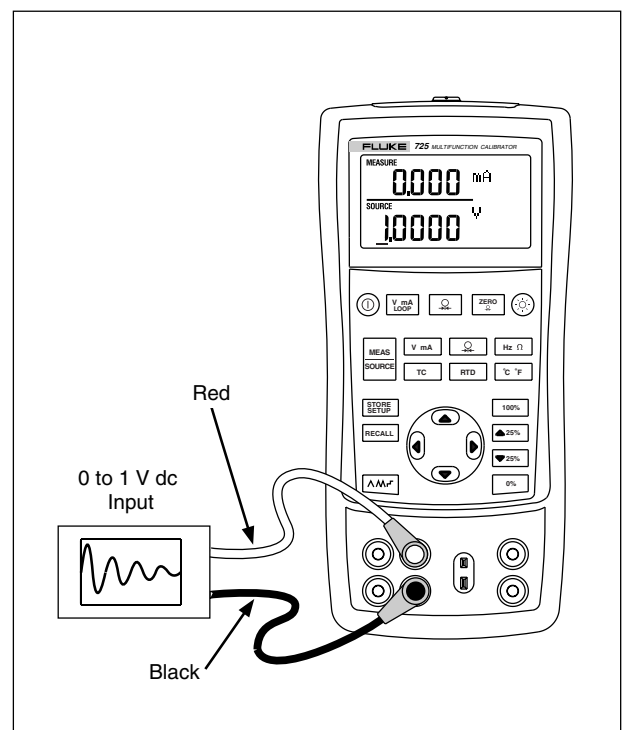

Figure 22. Calibrating a Chart Recorder

sh25f.eps

Remote Control Commands

You can control the calibrator remotely from a PC running a terminal emulator program. The remote control commands give access to all capabilities of the calibrator with the exception of pressure measurement. See Table 8A-8C for the remote commands and explanations.

The Fluke 700SC Serial Interface Cable Assembly (PN 667425) plugs into the pressure module connector and

terminates in a DB-9 connector which plugs directly into a PC serial port. A DB-9 to DB-25 adapter is required to connect to a PC.

The remote control interface on the 725 is activated by turning the calibrator off, then turning it on again while depressing the  key. The calibrator will initialize with its remote port enabled. The terminal emulator connected to the calibrator should be set up for: 9600 baud, no parity, 8 data bits, and 1 stop bit.

Table 8A. Remote Control Upper Display

Serial Input	Description
j	mA measurement
L	mA Loop Power
E	Volts measurement
B	Single broadcast of most recent upper display value and units

Table 8B. Remote Control Lower Display

Serial Input	Description
A	mA measurement
a	mA source
l	mA 2W Sim
V	Volts measurement
v	Volts source
M	mV measurement
m	mV source
K	KHz measurement

Table 8B. Remote Control Lower Display (cont)

Serial Input	Description
k	KHz source
H	Hz measurement
h	Hz source
P	CPM measurement
p	CPM source
O	Ohms measurement (default 2W)
o	Select Ohms source
W	2-wire measurement (Ohms and RTDs)
X	3-wire measurement (Ohms and RTDs)
Y	4-wire measurement (Ohms and RTDs)
T	Thermocouple measurement (default Type J) use "S" command to select sensor type
t	Thermocouple source (default Type J) use "S" command to select sensor type
C	Selects Centigrade (T/C-RTD)
F	Selects Fahrenheit (T/C-RTD)
R	RTD measurement mode (default Pt100 385) use "S" command to select sensor type
r	RTD measurement mode (default Pt100 385) use "S" command to select sensor type
u	Increment display source value
d	Decrement display source value
<	The < arrow key PC keyboard selects left arrow on 725
>	The > arrow key PC keyboard selects right arrow on 725

Table 8B. Remote Control Lower Display (cont)

Serial Input	Description
0-9 - , . <CR>	Enter a source value using ascii characters 0,1,2,...9,-,.,terminated by <CR> (carriage return)
b	Single Broadcast of most recent lower display value and units

Table 8C. "S" Commands Select Sensor Type

Serial Input	Selection Entry		RTD Type
	No.	Thermocouple Type	
S	1	J	Pt100 (3926)
	2	K	Pt100 (385)
	3	T	Pt100 (3916)
	4	E	Pt200 (385)
	5	R	Pt500 (385)
	6	S	Pt1000 (385)
	7	B	Ni120
	8	L	
	9	U	
	A	N	
	B	mV	

Replacing the Batteries

Warning

To avoid false readings, which could lead to possible electric shock or personal injury, replace the batteries as soon as the battery indicator () appears.

Figure 23 shows you how to replace the battery.

Replacing the Fuses

The calibrator comes equipped with two 0.05A, 250V, socketed fuses to protect the calibrator.

Warning

To avoid electrical shock, remove the test leads from the calibrator before opening the battery door. Close and latch the battery door before using the calibrator.

The fuses can be removed and checked for resistance. A value of $< 10 \Omega$ is good. Problems while measuring using the right jacks indicate that F3 may have opened. If you can't measure or source current with the left jacks, F4 may have opened. To replace the fuses, refer to Figure 23 and perform the following steps:

1. Turn the calibrator off, remove the test leads from the terminals, and hold the calibrator face down.
2. Using a flat-blade screwdriver, turn the battery door screws 1/4-turn counterclockwise and remove the battery door.
3. Remove and replace the damaged fuse.
4. Replace the battery door and secure it by turning the screws 1/4-turn clockwise.

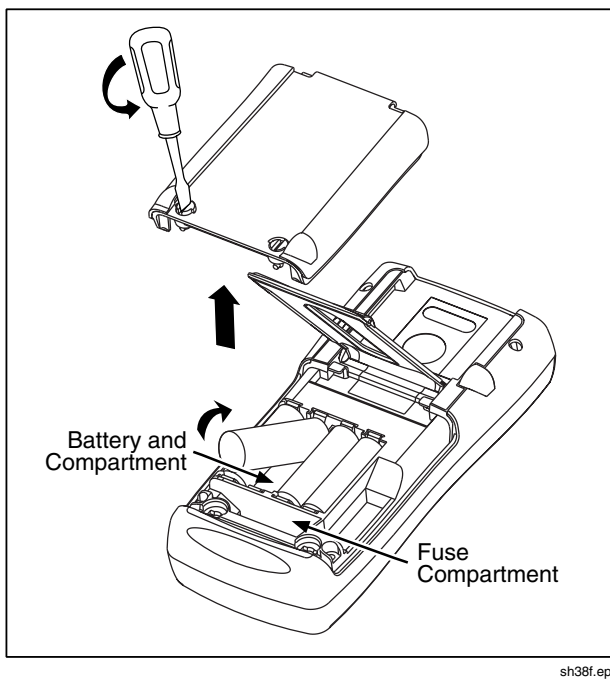

Figure 23. Replacing the Batteries

Maintenance

Cleaning the Calibrator

⚠ Warning

To avoid personal injury or damage to the calibrator, use only the specified replacement parts and do not allow water into the case.

Caution

To avoid damaging the plastic lens and case, do not use solvents or abrasive cleansers.

Clean the calibrator and pressure modules with a soft cloth dampened with water or water and mild soap.

Service Center Calibration or Repair

Calibration, repairs, or servicing not covered in this manual should be performed only by qualified service personnel. If the calibrator fails, check the batteries first, and replace them if needed.

Verify that the calibrator is being operated in accordance with the instructions in this manual. If the calibrator is faulty, send a description of the failure with the calibrator. Pressure modules do not need to accompany the calibrator unless the module is faulty also. Be sure to

pack the calibrator securely, using the original shipping container if it is available. Send the equipment postage paid and insured, to the nearest Service Center. Fluke assumes no responsibility for damage in transit.

The Fluke 725 calibrator covered by the warranty will be promptly repaired or replaced (at Fluke's option) and returned to you at no charge. See the back of the title page for warranty terms. If the warranty period has expired, the calibrator will be repaired and returned for a fixed fee. If the calibrator or pressure module is not covered under the warranty terms, contact an authorized service center for a price quote for repair.

To locate an authorized service center, refer to "Contacting Fluke" at the beginning of the manual.

Replacement Parts

Table 9 lists the part number of each replaceable part. Refer to Figure 24.

Table 9. Replacement Parts

Item	Description	PN	Qty.
1	Case top	664232	1
2	LCD mask	664273	1
3	Elastomeric strips	802063	2
4	Input/output bracket	691391	1
5	LCD bracket	667287	1

6	Mounting screws	494641	11
7	Backlight	690336	1
8	LCD	690963	1
9	Keypad	690955	1
10	Case bottom	664235	1
11	AA alkaline batteries	376756	4
12	Case screws	832246	4
13	Battery door	664250	1
14	Accessory mount	658424	1
15	Tilt stand	659026	1
16	Battery door 1/4-turn fasteners	948609	2
17	TL75 series test leads	855742	1
18	Test lead, red	688051	1
	Test lead, black	688066	1
19	<i>725 Product Overview Manual</i>	1549644	1
20	AC72 alligator clip, red	1670641	1
	AC72 alligator clip, black	1670652	1
21	CD ROM, contains User Manual	1549615	1
22	Input Decal	690948	1
23	Fuse 0.05A/250V	2002234	2

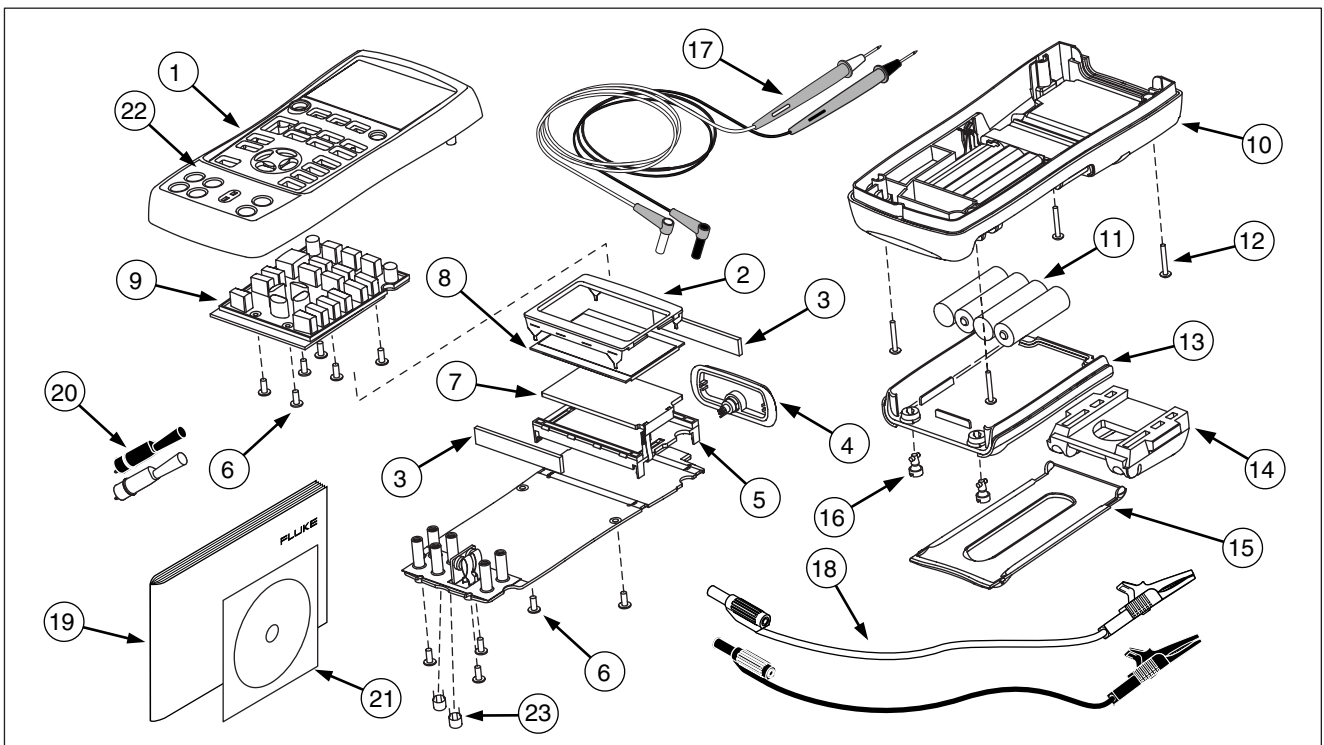

Figure 24. Replacement Parts

zi45f.eps

Accessories

For more information about these accessories and their prices, contact your Fluke representative. Pressure Modules and Fluke model numbers (see Table 10) are listed below. (Differential models also operate in gage mode.) Contact your Fluke representative about new pressure modules not listed here.

- 700HTP 0 to 10,000 PSI Pump
- 700PTP -11.6 to 360 PSI Pump
- 700TC1 and 700TC2 Thermocouple Mini-plug Kits

External Fluke Pressure Module Compatibility

The output of Fluke 700P pressure modules can cause the 725's 5 digit display to overflow, or else produce values that are too low to be read if inappropriate units are selected. This is prevented by displaying OL on the display per the following table.

Table 10. Fluke Pressure Module Compatibility

Pressure Unit	Module Compatibility
Psi	Available on all pressure ranges
In. H ₂ O	All ranges through 3000 psi
cm. H ₂ O	All ranges through 1000 psi
Bar	15 psi and above
Mbar	All ranges through 1000 psi
KPa	Available on all pressure ranges
In.Hg.	Available on all pressure ranges
mm. Hg	All ranges through 1000 psi
Kg/cm ²	15 psi and above

Table 11. Pressure Modules

Fluke Model Number	Range	Type and Media
Fluke-700P00	0 to 1" H ₂ O	differential, dry
Fluke-700P01	0 to 10" H ₂ O	differential, dry
Fluke-700P02	0 to 1 psi	differential, dry
Fluke-700P22	0 to 1 psi	differential, wet
Fluke-700P03	0 to 5 psi	differential, dry
Fluke-700P23	0 to 5 psi	differential, wet
Fluke-700P04	0 to 15 psi	differential, dry
Fluke-700P24	0 to 15 psi	differential, wet
Fluke-700P05	0 to 30 psi	gage, wet
Fluke-700P06	0 to 100 psi	gage, wet
Fluke-700P27	0 to 300 psi	gage, wet
Fluke-700P07	0 to 500 psi	gage, wet
Fluke-700P08	0 to 1,000 psi	gage, wet
Fluke-700P09	0 to 1,500 psi	gage, wet

Table 11. Pressure Modules (cont.)

Fluke Model Number	Range	Type and Media
Fluke-700P29	0 to 3,000 psi	gage, wet
Fluke-700P30	0 to 5,000 psi	gage, wet
Fluke-700P31	0 to 10,000 psi	gage, wet
Fluke-700PA3	0 to 5 psi	absolute, wet
Fluke-700PA4	0 to 15 psi	absolute, wet
Fluke-700PA5	0 to 30 psi	absolute, wet
Fluke-700PA6	0 to 100 psi	absolute, wet
Fluke-700PV3	0 to -5 psi	vacuum, dry
Fluke-700PV4	0 to -15 psi	vacuum, dry
Fluke-700PD2	±1 psi	dual range, dry
Fluke-700PD3	±5 psi	dual range, dry
Fluke-700PD4	±15 psi	dual range, dry
Fluke-700PD5	-15/+30 psi	dual range, wet
Fluke-700PD6	-15/+100 psi	dual range, wet
Fluke-700PD7	-15/+200 psi	dual range, wet

Specifications

Specifications are based on a one year calibration cycle and apply from +18 °C to +28 °C unless stated otherwise. All specifications assume a 5 minute warmup period.

DC Voltage Measurement

Range	Resolution	Accuracy, (% of Reading + Counts)
30 V (upper display)	0.001 V	0.02 % + 2
20 V (lower display)	0.001 V	0.02 % + 2
90 mV	0.01 mV	0.02 % + 2
Temperature coefficient -10 °C to 18 °C, +28 °C to 55 °C: ±0.005 % of range per °C		

DC Voltage Source

Range	Resolution	Accuracy, (% of Reading + Counts)
100 mV	0.01 mV	0.02 % + 2
10 V	0.001 V	0.02 % + 2
Temperature coefficient -10 °C to 18 °C, +28 °C to 55 °C: ±0.005 % of range per °C		
Maximum load: 1 mA		

Millivolt Measurement and Source*

Range	Resolution	Accuracy
-10 mV to 75 mV	0.01 mV	±(0.025 % + 1 count)
Maximum input voltage: 30 V		
Temperature coefficient -10 °C to 18 °C, +28 °C to 55 °C: ±0.005 % of range per °C		
*Select this function by pressing <input type="checkbox"/> TC. The signal is available at the thermocouple miniplug connector.		

DC mA Measurement and Source

Range	Resolution	Accuracy, (% of Reading + Counts)
24 mA	0.001 mA	0.02 % + 2
Temperature coefficient -10 °C to 18 °C, +28 °C to 55 °C: ±0.005 % of range per °C Drive capability: 1000 Ω at 20 mA		

Ohms Measurement

Ohms Range	Accuracy ± Ω*	
	4-Wire	2- and 3-Wire
0 to 400 Ω	0.1	0.15
400 to 1.5 kΩ	0.5	1.0
1.5 to 3.2 kΩ	1	1.5
Temperature coefficient -10 °C to 18 °C, +28 °C to 55 °C: ±0.005 % of range per °C Excitation Current: 0.2 mA Maximum input voltage: 30 V * 2-wire: Does not include lead resistance. 3-wire: Assumes matched leads with a total resistance not exceeding 100 Ω.		

Ohms Source

Ohms Range	Excitation Current from Measurement Device	Accuracy ± Ω
15 to 400 Ω	0.15 to 0.5 mA	0.15
15 to 400 Ω	0.5 to 2 mA	0.1
400 to 1.5 kΩ	0.05 to 0.8 mA	0.5
1.5 to 3.2 kΩ	0.05 to 0.4 mA	1
Temperature coefficient -10 °C to 18 °C, +28 °C to 55 °C: ± 0.005 % of resistance range per °C		
Resolution		
15 to 400 Ω	0.1 Ω	
400 to 3.2 kΩ	1 Ω	

Frequency Measurement

Range	Resolution	Accuracy
2.0 to 1000.0 CPM	0.1 CPM	± (0.05 % + 1 count)
1 to 1000 Hz	0.1 Hz	± (0.05 % + 1 count)
1.0 to 10.0 kHz	0.01 kHz	± (0.05 % + 1 count)
Sensitivity: 1V peak-to-peak minimum Waveform: squarewave		

Frequency Source

Range	Resolution	Accuracy (% of output frequency)
2.0 to 1000.0 CPM	0.1 CPM	± 0.05 %
1 to 1000 Hz	1 Hz	± 0.05 %
1.0 to 10.0 kHz	0.1 kHz	± 0.25 %
Waveform: 5 V p-p squarewave, -0.1 V offset		

Temperature, Thermocouples

Type	Range	Measure and Source Accuracies (ITS-90)
J	-200 to 0 °C	1.0 °C
	0 to 1200 °C	0.7 °C
K	-200 to 0 °C	1.2 °C
	0 to 1370 °C	0.8 °C
T	-200 to 0 °C	1.2 °C
	0 to 400 °C	0.8 °C
E	-200 to 0 °C	0.9 °C
	0 to 950 °C	0.7 °C
R	-20 to 0 °C	2.5 °C
	0 to 500 °C	1.8 °C
	500 to 1750 °C	1.4 °C
S	-20 to 0 °C	2.5 °C
	0 to 500 °C	1.8 °C
	500 to 1750 °C	1.5 °C

B	600 to 800 °C	2.2 °C
	800 to 1000 °C	1.8 °C
	1000 to 1800 °C	1.4 °C
L	-200 to 0 °C	0.85 °C
	0 to 900 °C	0.7 °C
U	-200 to 0 °C	1.1 °C
	0 to 400 °C	0.75 °C
N	-200 to 0 °C	1.5 °C
	0 to 1300 °C	0.9 °C
XK	-200 to -100 °C	0.5 °C
	-100 to 800 °C	0.6 °C
BP	0 to 800 °C	1.2 °C
	800 to 2500 °C	2.5 °C
Resolution:		
J, K, T, E, L, N, U, XK, BP:		0.1 °C, 0.1 °F
B, R, S:		1 °C, 1 °F

Loop Power Supply

Voltage: 24 V

Maximum current: 22 mA

Short circuit protected

RTD Excitation (simulation)

Allowable Excitation by RTD type	
Ni 120	0.15 to 3.0 mA
Pt 100-385	0.15 to 3.0 mA
Pt 100-392	0.15 to 3.0 mA
Pt 100-JIS	0.15 to 3.0 mA
Pt 200-385	0.15 to 3.0 mA
Pt 500-385	0.05 to 0.80 mA
Pt 1000-385	0.05 to 0.40 mA

Temperature, RTD Ranges, and Accuracies (ITS-90)

Type	Range °C	Accuracy		
		Measure 4-Wire °C	Measure 2- and 3-Wire* °C	Source °C
Ni120	-80 to 260	0.2	0.3	0.2
Pt100-385	-200 to 800	0.33	0.5	0.33
Pt100-392	-200 to 630	0.3	0.5	0.3
Pt100-JIS	-200 to 630	0.3	0.5	0.3
Pt200-385	-200 to 250	0.2	0.3	0.2
	250 to 630	0.8	1.6	0.8
Pt500-385	-200 to 500	0.3	0.6	0.3
	500 to 630	0.4	0.9	0.4
Pt1000-385	-200 to 100	0.2	0.4	0.2
	100 to 630	0.2	0.5	0.2

Resolution: 0.1 °C, 0.1 °F**Allowable excitation current (source):** Ni120, Pt100-385, Pt100-392, Pt100-JIS, Pt200-385: 0.15 to 3.0 mA

Pt500-385: 0.05 to 0.80 mA; Pt1000-385: 0.05 to 0.40 mA

RTD Source: Addresses pulsed transmitters and PLCs with pulses as short as 5 ms.

* 2-wire: Does not include lead resistance.

3-wire: Assumes matched leads with a total resistance not exceeding 100 Ω.

Pressure Measurement

Range	Resolution	Accuracy	Units
Determined by pressure module	5 digits	Determined by pressure module	psi, inH ₂ O@4 °C, inH ₂ O@20 °C, kPa, cmH ₂ O@4 °C, cmH ₂ O@20 °C, bar, mbar, kg/cm ₂ , mmHg, inHg

General Specifications

Operating temperature	-10 °C to 55 °C
Storage temperature	- 20 °C to 71 °C
Operating altitude	3000 meters above mean sea level
Relative Humidity (% RH operating without condensation)	90 % (10 to 30 °C) 75 % (30 to 40 °C) 45 % (40 to 50 °C) 35 % (50 to 55 °C) uncontrolled < 10 °C
Vibration	Random, 2 g, 5 to 500 Hz
Safety	EN 61010-1:1993, ANSI/ISA S82.01-1994; CAN/CSA C22.2 No 1010.1:1992
Power requirements	4 AA alkaline batteries
Size	96 x 200 x 47 mm. (3.75 x 7.9 x 1.86 in)
Weight	650 gm (1 lb, 7 oz)

Index

—0—

0% output parameter, setting, 36

—1—

100% output parameter, setting, 36

—4—

4 to 20 mA transmitter
simulating, 28

—A—

Accessories, 52
Auto ramping output, 37

—B—

Battery, replacing, 48

—C—

Calibration, 49
Cleaning calibrator, 49
Connections
 for pressure measurement, 25
 for pressure sourcing, 35

—D—

Display, 13

—E—

Electrical parameters
 measurement, 18
 sourcing, 28

—G—

Getting started, 14

—I—

I/P device, calibrating, 42
Input terminals, 8
Input/output terminals and connectors
 (table), 9

—K—

Key functions (table), 11
Keys, 10

—L—

Loop power
 simulating, 28
 supplying, 16

—M—

Measure functions, summary (table), 2
Measure mode, 16
Measuring
 pressure, 25
 temperature with RTDs, 22
 temperature with thermocouples, 19

—O—

Output device, testing, 44
Output terminals, 8

—P—

Parts list, 50

Pressure modules available, 52
Pressure modules, zeroing, 26
Pressure transmitter, calibrating, 40

—R—

Recalling setups, 37
Remote control commands, 45
Repair, 49
RTD
 simulating, 31
RTD
 measuring, 22
 types, 22

—S—

Safety information, 3
Servicing, 49
Setup
 recalling, 37
 storing, 37
Thermocouple, 31
Simulating
 loop power, 28
 RTD, 31
 thermocouples, 31
Source functions, summary (table), 2

Source mode, 28
Sourcing
 4 to 20 mA, 28
 electrical parameters, 28
 pressure, 34
 thermocouples, 31
Specifications, 55
Standard equipment, 3
Stepping output, 36
Storing setups, 37

—T—

Temperature
 measuring with RTD, 22
 measuring with thermocouple, 19
Terminals
 input, 8
 output, 8
Thermocouple
 measuring, 19
 measuring temperature, 19
 sourcing, 31
 types, 19
Transmitter
 4 to 20 mA, simulating, 28
 Transmitter, calibrating, 38

—Z—

Zeroing pressure modules, 26



9100S
Dry-Well Calibrator
Users Guide

9100S__ugeng0000

Limited Warranty & Limitation of Liability

Each product from Fluke Corporation, (“Fluke”) is warranted to be free from defects in material and workmanship under normal use and service. The warranty period is one year for Dry-Well Calibrators. The warranty period begins on the date of the shipment. Parts, product repairs, and services are warranted for 90 days. The warranty extends only to the original buyer or end-user customer of a Fluke authorized reseller, and does not apply to fuses, disposable batteries or to any other product, which in Fluke’s opinion, has been misused, altered, neglected, or damaged by accident or abnormal conditions of operation or handling. Fluke warrants that software will operate substantially in accordance with its functional specifications for 90 days and that it has been properly recorded on non-defective media. Fluke does not warrant that software will be error free or operate without interruption. Fluke does not warrant calibrations on the Field Metrology Well.

Fluke authorized resellers shall extend this warranty on new and unused products to end-user customers only but have no authority to extend a greater or different warranty on behalf of Fluke. Warranty support is available if product is purchased through a Fluke authorized sales outlet or Buyer has paid the applicable international price. Fluke reserves the right to invoice Buyer for importation costs of repairs/replacement parts when product purchased in one country is submitted for repair in another country.

Fluke’s warranty obligation is limited, at Fluke’s option, to refund of the purchase price, free of charge repair, or replacement of a defective product which is returned to a Fluke authorized service center within the warranty period.

To obtain warranty service, contact your nearest Fluke authorized service center or send the product, with a description of the difficulty, postage, and insurance prepaid (FOB Destination), to the nearest Fluke authorized service center. Fluke assumes no risk for damage in transit. Following warranty repair, the product will be returned to Buyer, transportation prepaid (FOB Destination). If Fluke determines that the failure was caused by misuse, alteration, accident or abnormal condition or operation or handling, Fluke will provide an estimate or repair costs and obtain authorization before commencing the work. Following repair, the product will be returned to the Buyer transportation prepaid and the Buyer will be billed for the repair and return transportation charges (FOB Shipping Point).

THIS WARRANTY IS BUYER’S SOLE AND EXCLUSIVE REMEDY AND IS IN LIEU OF ALL OTHER WARRANTIES, EXPRESS OR IMPLIED, INCLUDING BUT NOT LIMITED TO ANY IMPLIED WARRANTY OF MERCHANTABILITY OR FITNESS FOR A PARTICULAR PURPOSE. FLUKE SHALL NOT BE LIABLE FOR ANY SPECIAL, INDIRECT, INCIDENTAL, OR CONSEQUENTIAL DAMAGES OR LOSSES, INCLUDING LOSS OF DATA, WHETHER ARISING FROM BREACH OF WARRANTY OR BASED ON CONTRACT, TORT, RELIANCE OR ANY OTHER THEORY.

Since some countries or states do not allow limitation of the term of an implied warranty, or exclusion or limitation of incidental or consequential damages, the limitations and exclusions of this warranty may not apply to every buyer. If any provision of this Warranty is held invalid or unenforceable by a court of competent jurisdiction, such holding will not affect the validity or enforceability of any other provision.

Specifications subject to change without notice. • Copyright © 2005 • Printed in USA

Table of Contents

1	Before You Start	1
1.1	Introduction.....	1
1.2	Symbols Used.....	1
1.3	Safety Information.....	3
1.3.1	Warnings	3
1.3.2	Cautions	4
1.4	Authorized Service Centers.....	5
2	Specifications and Environmental Conditions.....	9
2.1	Specifications	9
2.2	Environmental Conditions	9
3	Quick Start.....	11
3.1	Unpacking	11
3.2	Set-up	11
3.3	Power.....	11
3.4	Setting the Temperature.....	11
4	Parts and Controls.....	13
4.1	Rear Panel	13
4.2	Side View	14
4.3	Front Panel.....	15
4.4	Constant Temperature Block Assembly.....	15
5	General Operation.....	17
5.1	Setting the Temperature.....	17
5.2	Changing Display Units	17
6	Controller Operation.....	19
6.1	Well Temperature	19
6.2	Temperature Set-point	19
6.2.1	Programmable Set-points	19
6.2.2	Set-point Value	20
6.2.3	Temperature Scale Units	20
6.3	Scan.....	20

9100S Dry-Well Calibrator

6.3.1	Scan Control.....	22
6.3.2	Scan Rate.....	22
6.4	Set-point Resistance.....	22
6.5	Secondary Menu.....	23
6.6	Heater Power	23
6.7	Proportional Band	23
6.8	Controller Configuration.....	24
6.9	Operating Parameters	25
6.10	High Limit.....	25
6.11	Serial Interface Parameters	25
6.11.1	Baud Rate	25
6.11.2	Sample Period.....	26
6.11.3	Duplex Mode.....	26
6.11.4	Linefeed	27
6.12	Calibration Parameters	27
6.12.1	Hard Cutout.....	28
6.12.2	R0.....	28
6.12.3	ALPHA.....	28
6.12.4	DELTA.....	29
7	Digital Communication Interface.....	31
7.1	RS-232 Connection.....	31
7.2	Interface Commands.....	32
8	Test Probe Calibration.....	35
8.1	Calibrating a Single Probe.....	35
8.2	Dry-well Characteristics.....	35
8.2.1	Stabilization and Accuracy	35
9	Calibration Procedure.....	37
9.1	Calibration Points.....	37
9.2	Calibration Procedure.....	37
9.2.1	Compute DELTA.....	38
9.2.2	Compute R0 and ALPHA	38
9.2.3	Accuracy and Repeatability.....	39
10	Maintenance	41



11 Troubleshooting43

- 11.1 Troubleshooting Problems, Possible Causes, and Solutions..... 43
- 11.2 CE Comments..... 44
 - 11.2.1 EMC Directive 44
 - 11.2.2 Low Voltage Directive (Safety) 44



Tables

Table 1 International Electrical Symbols 1
Table 2 Controller communications commands 32



Figures

Figure 1 Back Panel..... 13
Figure 2 Side view of the 9100S showing the prop stand 14
Figure 3 Front panel..... 15
Figure 4 Fixed block options 16
Figure 5 Controller operation flow chart 21
Figure 6 Serial cable wiring 31

1 Before You Start

1.1 Introduction

The Fluke 9100S Mid-Range Field Calibrator may be used as a portable instrument or bench top temperature calibrator for calibrating thermocouple and RTD temperature probes. This instrument is small enough to use in the field, and accurate enough to use in the lab. Calibrations may be done over a range of 35°C to 375°C (95°F to 707°F). Temperature display and setability resolution is 0.1 degrees.

The instrument features:

- Rapid heating and cooling
- Prop stand
- RS-232 interface capability

Built in programmable features include:

- Temperature scan rate control
- Eight set-point memory
- Adjustable readout in °C or °F

The temperature is accurately controlled by Fluke's digital controller. The controller uses a precision platinum RTD as a sensor and controls the well temperature with a triac driven heater.

The LED front panel continuously shows the current well temperature. The temperature may be set, using the control buttons, to any desired temperature within the instrument's range. Multiple fault protection devices insure user and instrument safety and protection.

This dry-well calibrator was designed for portability, low cost, and ease of operation. Through proper use, the instrument will provide continuous accurate calibration of temperature sensors and devices. The user should be familiar with the safety guidelines and operating procedures of the calibrator as described in the instruction manual.

1.2 Symbols Used















Table 1 lists the International Electrical Symbols. Some or all of these symbols may be used on the instrument or in this manual.

Table 1 International Electrical Symbols

Symbol	Description
	AC (Alternating Current)

9100S Dry-Well Calibrator

Symbols Used

Symbol	Description
	AC-DC
	Battery
	Complies with European Union directives
	DC
	Double Insulated
	Electric Shock
	Fuse
	PE Ground
	Hot Surface (Burn Hazard)
	Read the User's Guide (Important Information)
	Off
	On
	Canadian Standards Association
CAT II	CAT II OVERVOLTAGE (Installation) CATEGORY II, Pollution Degree 2 per IEC1010-1 refers to the level of Impulsive Withstand Voltage protection provided. Equipment of OVERVOLTAGE CATEGORY II is energy-consuming equipment to be supplied from the fixed installation. Examples include household, office, and laboratory appliances.
	C-TICK Australian EMC mark
	The European Waste Electrical and Electronic Equipment (WEEE) Directive (2002/96/EC) mark.

1.3 Safety Information

Use this instrument only as specified in this manual. Otherwise, the protection provided by the instrument may be impaired. Refer to the safety information in the Warnings and Cautions sections below.

The following definitions apply to the terms “Warning” and “Caution”.

- “Warning” identifies conditions and actions that may pose hazards to the user.
- “Caution” identifies conditions and actions that may damage the instrument being used.

1.3.1 Warnings

To avoid personal injury, follow these guidelines.

GENERAL

- **DO NOT** use this instrument in environments other than those listed in the User’s Guide.
- Inspect the instrument for damage before each use. **DO NOT** use the instrument if it appears damaged or operates abnormally.
- Follow all safety guidelines listed in the user’s manual.
- Calibration Equipment should only be used by Trained Personnel.
- If this equipment is used in a manner not specified by the manufacturer, the protection provided by the equipment may be impaired.
- Before initial use, or after transport, or after storage in humid or semi-humid environments, or anytime the dry-well has not been energized for more than 10 days, the instrument needs to be energized for a “dry-out” period of 2 hours before it can be assumed to meet all of the safety requirements of the IEC 1010-1. If the product is wet or has been in a wet environment, take necessary measures to remove moisture prior to applying power such as storage in a low humidity temperature chamber operating at 50 degree centigrade for 4 hours or more.
- **DO NOT** use this instrument for any application other than calibration work. The instrument was designed for temperature calibration. Any other use of the instrument may cause unknown hazards to the user.
- Completely unattended operation is not recommended.
- Overhead clearance is required. **DO NOT** place the instrument under a cabinet or other structure. Always leave enough clearance to allow for safe and easy insertion and removal of probes.
- If the instrument is used in a manner not in accordance with the equipment design, the operation of the dry-well may be impaired or safety hazards may arise.
- This instrument is intended for indoor use only.

9100S Dry-Well Calibrator

Safety Information

BURN HAZARDS

- **DO NOT** turn the instrument upside down with the inserts in place; the inserts will fall out.
- **DO NOT** operate near flammable materials.
- Use of this instrument at **HIGH TEMPERATURES** for extended periods of time requires caution.
- **DO NOT** touch the well access surface of the instrument.
- The block vent may be very hot due to the fan blowing across the heater block of the dry-well.
- The temperature of the well access is the same as the actual display temperature, e.g. if the instrument is set to 375°C and the display reads 375°C, the well is at 375°C.
- For top loading dry-wells, the top sheet metal of the dry-well may exhibit extreme temperatures for areas close to the well access.
- The air over the well can reach temperatures greater than 200°C for high temperature (400°C and higher) dry-wells. Note: Probes and inserts may be hot and should only be inserted and removed from the instrument when the instrument is set at temperatures less than 50°C. Use extreme care when removing hot inserts.
- **DO NOT** turn off the instrument at temperatures higher than 100°C. This could create a hazardous situation. Select a set-point less than 100°C and allow the instrument to cool before turning it off.
- The high temperatures present in dry-wells designed for operation at 300°C and higher may result in fires and severe burns if safety precautions are not observed.

ELECTRICAL SHOCK

- **DO NOT** operate this instrument without a properly grounded, properly polarized power cord. Electric shock may result.
- **DO NOT** connect this instrument to a non-grounded, non-polarized outlet. Ensure the earth ground to the outlet is properly connected. Electrical shock may result if the outlet is not installed correctly.
- Always replace the power cord with an approved cord of the correct rating and type.
- **HIGH VOLTAGE** is used in the operation of this equipment. **SEVERE INJURY** or **DEATH** may result if personnel fail to observe safety precautions. Before working inside the equipment, turn power off and disconnect power cord.
- If supplied with user accessible fuses, always replace the fuse with one of the same rating, voltage and type.

1.3.2 Cautions

- Always operate this instrument at room temperature between 41°F and 122°F (5°C to 50°C). Allow sufficient air circulation by leaving at least 6 inches (15

cm) of clearance around the instrument.

- Component lifetime can be shortened by continuous high temperature operation.
- **DO NOT** use fluids to clean out the well.
- Never introduce any foreign material into the probe hole of the insert. Fluids, etc. can leak into the instrument causing damage.
- **DO NOT** change the values of the calibration constants from the factory set values. The correct setting of these parameters is important to the safety and proper operation of the calibrator.
- **DO NOT** drop the probe sheath in to the well. This type of action can cause a shock to the sensor and affect the calibration.
- The instrument and any thermometer probes used with it are sensitive instruments that can be easily damaged. Always handle these devices with care. **DO NOT** allow them to be dropped, struck, stressed, or overheated.
- The Factory Reset Sequence (see Section 11, Troubleshooting, on page 43) should be performed only by authorized personnel if no other action is successful in correcting a malfunction. You must have a copy of the most recent Report of Calibration to restore the calibration parameters.
- **DO NOT** operate this instrument in an excessively wet, oily, dusty, or dirty environment. Always keep the well and inserts clean and clear of foreign material.
- The dry-well is a precision instrument. Although it has been designed for optimum durability and trouble free operation, it must be handled with care. Always carry the instrument in an upright position to prevent the probe sleeves from dropping out.
- If a mains supply power fluctuation occurs, immediately turn off the instrument. Power bumps from brown-outs could damage the instrument. Wait until the power has stabilized before re-energizing the instrument.
- The prop stand was not designed to be used as a handle for carrying the instrument. To avoid damage, do not force the prop stand beyond the incline positions of the instrument.
- Allow for probe expansion inside the well as the block heats.
- Most probes have handle temperature limits. Be sure that the probe handle temperature limit is not exceeded in the air above the instrument.

1.4 Authorized Service Centers

Please contact one of the following authorized Service Centers to coordinate service on your Fluke product:

2 Specifications and Environmental Conditions

2.1 Specifications

Range	35°C to 375°C (95°F to 707°F)
Accuracy	±0.25°C at 50°C ±0.25°C at 100°C ±0.5°C at 375°C
Stability	±0.07°C at 50°C ±0.1°C at 100°C ±0.3°C at 375°C
Resolution	0.1°C or °F
Well-to-Well Uniformity	±0.2°C with sensors of similar size at equal depths within wells
Heating Times	35 to 375°C: 9.5 minutes
Stabilization	5 minutes
Cooling Times	375 to 100°C: 14 minutes
Well Depth	4 inches (102 mm) 1/16 inch (1.6 mm) hole is 3.5 inches (89 mm) deep
Fixed Block Options	See Section , Constant Temperature Block Assembly, on page and Figure on page
Power	115 VAC (±10%), 55–65 Hz, 1.5 A or 230 VAC (±10%), 0.8 A, 45–55 Hz, 175 W
Size	2.25" H x 4.9" W x 6.1"D (57 mm x 125 mm x 150 mm)
Weight	2 lb. 3 oz. (1.08 Kg)
Safety	Conforms to EN61010-1 Conforms to CAN/CSA C22.2 No.1010.1 UL3111 and ANSI/ISA-S82.01 OVERVOLTAGE (Installation) CATEGORY II, Pollution Degree 2 per IEC1010-1
Fault Protection	Sensor burnout protection, over-temperature cutout, and electrical fuses
Fuse Rating	250 V 3 A FF (very fast acting) NO USER SERVICEABLE PARTS

2.2 Environmental Conditions

Although the instrument has been designed for optimum durability and trouble-free operation, it must be handled with care. The instrument should not be operated in an excessively dusty or dirty environment. Maintenance and cleaning recommendations can be found in the Maintenance Section of this manual.

The instrument operates safely under the following conditions:

- temperature range: 5–50°C (41–122°F)
- ambient relative humidity: 15–50%
- pressure: 75kPa–106kPa
- mains voltage within ±10% of nominal
- vibrations in the calibration environment should be minimized
- altitudes less than 2000 meters
- indoor use only

3 Quick Start

3.1 Unpacking

Unpack the dry-well carefully and inspect it for any damage that may have occurred during shipment. If there is shipping damage, notify the carrier immediately.

Verify that the following components are present:

- 9100S Dry-well
- Power Cord
- User's Guide with Report of Calibration
- RS-232 Cable
- 9930 Interface-it Software and User's Guide

3.2 Set-up

Place the calibrator on a flat surface with at least 6 inches of free space around the instrument. Always leave enough clearance in front of the instrument to allow for safe and easy insertion and removal of probes. The prop stand may be swung down to raise the front of the instrument from a horizontal position. Plug the power cord into a grounded mains outlet. Observe that the nominal voltage corresponds to that indicated on the calibrator.

Turn on the power to the calibrator by toggling the power switch on. The fan should begin quietly blowing air through the instrument and the controller display should illuminate after 3 seconds. After a brief self-test the controller should begin normal operation. If the unit fails to operate please check the power connection.

The display should show the well temperature and the well heater will bring the temperature of the well to the set-point temperature.

After using the calibrator, allow the well to cool by setting the temperature to 25°C and waiting 1/2 hour before turning the instrument off.

3.3 Power

Plug the instrument power cord into a mains outlet of the proper voltage, frequency, and current capability. Refer to Section 3.1, Specifications, for the power details. Turn the instrument on using the switch on the rear panel. The instrument will turn on and begin to heat to the previously programmed temperature set-point. The front panel LED display will indicate the actual instrument temperature.

3.4 Setting the Temperature

Section explains in detail how to set the temperature set-point on the calibrator using the front panel keys. The procedure is summarized here.

1. Press "SET" twice to access the set-point value.
2. Press ▲ or ▼ arrow to change the set-point value.

3. Press “SET” to program in the new set-point.
4. Press and hold “EXIT” to return to the temperature display.

When the set-point temperature is changed the controller switches the well heater on or off to raise or lower the temperature. The displayed well temperature gradually changes until it reaches the set-point temperature. The well may require 5 to 10 minutes to reach the set-point depending on the span. Another 5 to 10 minutes is required to stabilize within $\pm 0.1^{\circ}\text{C}$ of the set-point. Ultimate stability may take 15 to 20 minutes more of stabilization time.

4 Parts and Controls

The user should become familiar with the dry-well calibrator and its parts: (See Figures 1, 2, and 3).

4.1 Rear Panel

Power Cord - The removable power cord, (Figure 1 on this page) attaches to the back side of the instrument. It plugs into a standard 115 VAC (optional 230 VAC) grounded socket.

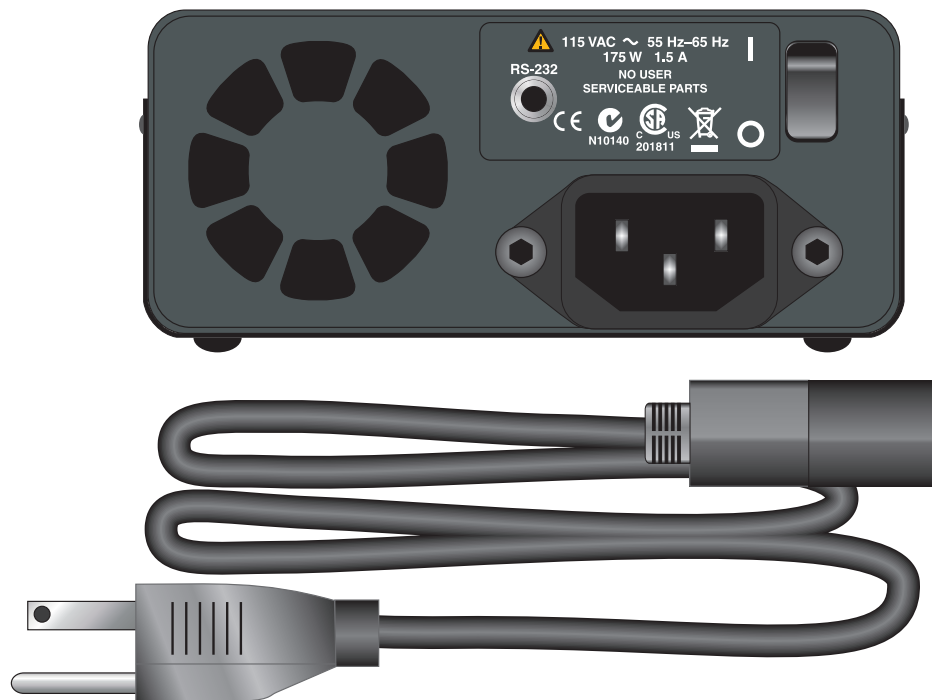

Figure 1 Back Panel

Power Switch - The power switch is located on the back panel of the instrument. The switch is either on or off. The on position is for normal operation. The off position disconnects power to the entire unit.

Fan - The fan inside the instrument runs continuously when the unit is being operated to provide cooling to the instrument. The fan has two speeds, a slow speed for control operation and a faster speed for rapid cooling. Slots at the top and around the corners of the instrument are provided for airflow. The area around the calibrator must be kept clear to allow adequate ventilation. The air is directed from the back to the front and may be hot. Allow 6 inches of open space around the calibrator to allow adequate ventilation.

9100S Dry-Well Calibrator

Side View

RS-232 - The RS-232 serial port provides a means for connecting the instrument to a computer or a printer using the included serial cable.



WARNING: Always leave enough clearance in front of the calibrator to allow for safe and easy installation and removal of probes.

4.2 Side View

Prop Stand - The prop stand (Figure 2 on this page) is located on the bottom side of the instrument and lays flat against the bottom of the instrument when not in use. The prop stand can be swung down into a standing position when using the instrument at an inclined position.

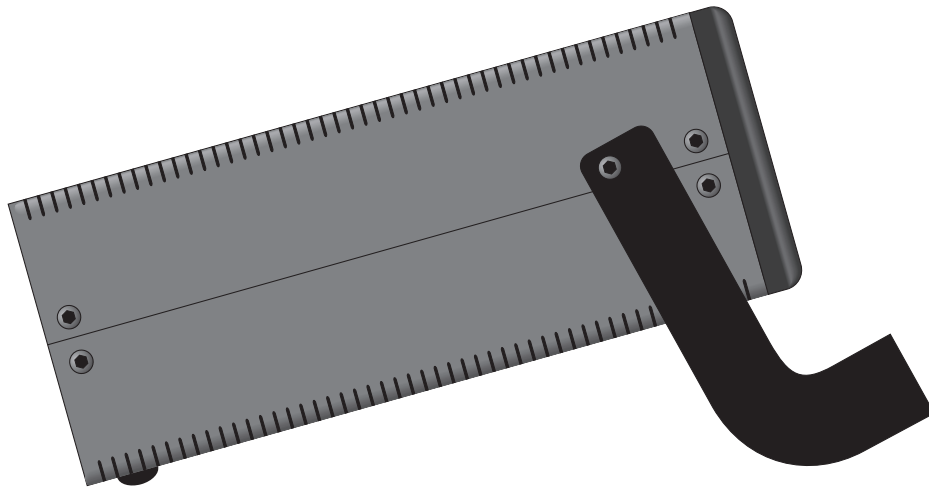
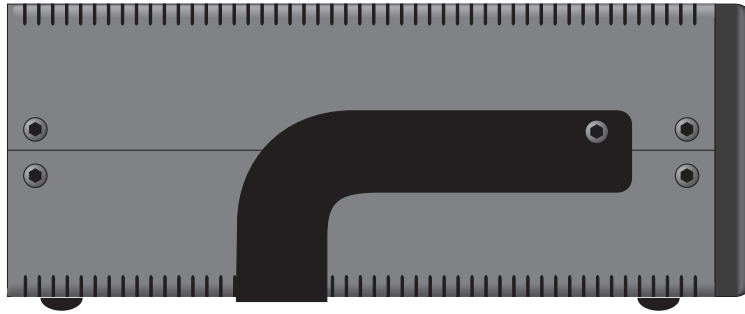

Figure 2 Side view of the 9100S showing the prop stand



CAUTION: The prop stand was not designed to be used as a handle for carrying the instrument. To avoid damage, do not force the prop stand beyond the inclined position of the instrument.

4.3 Front Panel

Well Block - Located on the right side of the front panel is the well opening where a block (Figure) designed to accept different probe sizes is installed. Each block is designed to accept different diameter temperature sensors. Four different blocks are available. See Section , Constant Temperature Block Assembly for details.

Controller Display - The digital display is an important part of the temperature controller because it not only displays set and actual temperatures but also various calibrator functions, settings, and constants. The display shows temperatures in units according to the selected scale °C or °F.

Controller Keypad - The four button keypad allows easy setting of the set-point temperature. The control buttons (**SET**, ▼, ▲, and **EXIT**) are used to set the calibrator temperature set-point, access and set other operating parameters, and access and set calibration parameters.



Figure 3 Front panel

Setting the control temperature is done directly in degrees of the current scale. It can be set to one-tenth of a degree Celsius or Fahrenheit.

The functions of the buttons are as follows:

SET – Used to display the next parameter in the menu and to store parameters to the displayed value.

▼ (down arrow) – Used to decrement the displayed value of parameters.

▲ (up arrow) – Used to increment the displayed value.

EXIT – Used to exit a function and to skip to the next function. Any changes made to the displayed value are ignored.

4.4 Constant Temperature Block Assembly

The “Block” is made of aluminum and provides a relatively constant and accurate temperature environment in which the sensor that is to be calibrated is inserted. A high-temperature platinum RTD imbedded in the block assembly senses and controls

9100S Dry-Well Calibrator

Constant Temperature Block Assembly

the temperature of the block. The entire assembly is suspended in an air cooled chamber thermally isolated from the chassis and electronics.



WARNING: *The opening in front of the block may be very hot due to air blowing forward.*

The constant temperature block is available in the following configurations.

Block “A” has six holes, four that accept probe diameters of 1/4”, 5/32”, 1/8”, and 1/16”, and two that accept probes of 3/16” diameter to allow comparison calibrations.

Block “B” has four holes that accept probe diameters of 3/8”, 1/4”, 3/16” and 1/8”.

Block “C” has two holes that accept probe diameters of 3/16” and 1/2”.

Block “D” has six holes, two that accept probe diameter of 3 mm, two that accept probes of 4 mm diameter, and two that accept probes of 6 mm diameter.

Surrounding the well opening are small ventilation holes which provide cooling to the instrument.

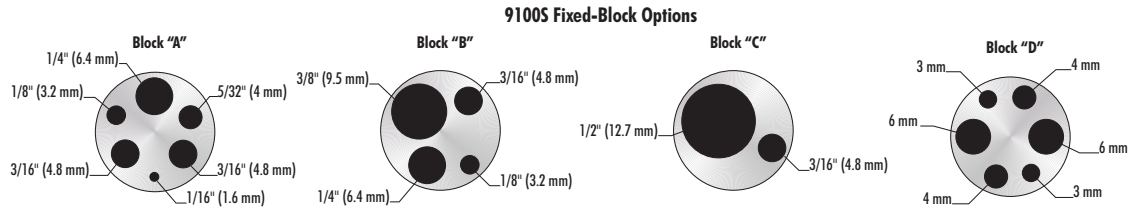

Figure 4 Fixed block options

5 General Operation

5.1 Setting the Temperature

Section explains in detail how to set the temperature set-point on the calibrator using the front panel keys. The procedure is summarized here.

1. Press “SET” twice to access the set-point value.
2. Press ▲ or ▼ to change the set-point value.
3. Press “SET” to program in the new set-point.
4. Press and hold “EXIT” to return to the temperature display.

When the set-point temperature is changed the controller switches the well heater on or off to raise or lower the temperature. The displayed well temperature gradually changes until it reaches the set-point temperature. The well may require 5 to 10 minutes to reach the set-point depending on the span. Another 5 to 10 minutes is required to stabilize within $\pm 0.1^{\circ}\text{C}$ of the set-point. Ultimate stability may take 15 to 20 minutes more of stabilization time.

5.2 Changing Display Units

This instrument can display temperature in Celsius or Fahrenheit. The temperature units are shipped from the factory set to Celsius. There are two ways to change to Fahrenheit or back to Celsius:

5. Press the “SET” and ▲ simultaneously. The temperature display changes units.
or

6. Press the “SET” key three times from the temperature display to show

$U n = \text{C}$

7. Press the ▲ or ▼ key to change units.
8. Press “SET” to save the setting or “EXIT” to continue without changing the setting.

6 Controller Operation

This chapter discusses in detail how to operate the dry-well temperature controller using the front control panel. Using the front panel key-switches and LED display the user may monitor the well temperature, set the temperature set-point in degrees C or F, monitor the heater output power, adjust the controller proportional band, and program the calibration parameters, operating parameters, and serial interface configuration. Operation of the functions and parameters are shown in the flowchart in Figure 5 on page 21. This chart may be copied for reference.

In the following discussion a button with the word SET or EXIT inside or ▲, and ▼, indicates the panel button while the dotted box indicates the display reading. Explanations of the button or display reading are to the right of each button or display value.

6.1 Well Temperature

The digital LED display on the front panel allows direct viewing of the actual well temperature. This temperature value is normally shown on the display. The units, C or F, of the temperature value are displayed at the right. For example,

100.0 C *Well temperature in degrees Celsius*

The temperature display function may be accessed from any other function by pressing and holding the “EXIT” button.

6.2 Temperature Set-point

The temperature set-point can be set to any value within the range and with resolution as given in the specifications. Be careful not to exceed the safe upper temperature limit of any device inserted into the well.

Setting the temperature involves selecting the set-point memory and adjusting the set-point value.

6.2.1 Programmable Set-points

The controller stores 8 set-point temperatures in memory. The set-points can be quickly recalled to conveniently set the calibrator to a previously programmed temperature set-point.

To set the temperature, first select the set-point memory. This function is accessed from the temperature display function by pressing “SET”. The number of the set-point memory currently being used is shown at the left on the display followed by the current set-point value.

100.0 C *Well temperature in degrees Celsius*



Access set-point memory

1 100. *Set-point memory 1 location, 100°C currently used*

To change to another set-point memory press the up or down arrow.

4 300. *New set-point memory 4 location, 300°C*

Press “SET” to accept the new selection and access the set-point value. Press “EXIT” to continue and to ignore any changes.



Accept selected set-point memory

6.2.2 Set-point Value

The set-point value may be adjusted after selecting the set-point memory and pressing “SET”.

4 200. *Set-point 4 value in°C*

If the set-point value does not need to be changed, press and hold “EXIT” to resume displaying the well temperature. To change the set-point value, press “SET” and then press the up or down arrow.

220.0 *New set-point value*

When the desired set-point value is reached, press “SET” to accept the new value and access the temperature scale units selection. If “EXIT” is pressed, any changes made to the set-point are ignored.



Accept new set-point value

6.2.3 Temperature Scale Units

The temperature scale units of the controller maybe set by the user to degrees Celsius (°C) or Fahrenheit (°F). The units are used in displaying the well temperature, set-point, proportional band, and high limit.

Press “SET” after adjusting the set-point value to change display units.

U n = C *Scale units currently selected*

Press the up or down arrow to change the units.

U n = F *New units selected*

Press “SET” to accept the new units or “EXIT” to cancel.

Note: The temperature scale units may also be changed by pressing “SET” and ▲ when the temperature is displayed. This action toggles the units between °F and °C.

6.3 Scan

The scan rate can be set and enabled so that when the set-point is changed the dry-well heats or cools at a specified rate (degrees per minute) until it reaches the new set-point. With the scan disabled the dry-well heats or cools at the maximum possible rate.

9100S Dry-Well Calibrator

Set-point Resistance

6.3.1 Scan Control

The scan is controlled with the scan on/off function that appears in the main menu after the temperature scale units.

5 c *5 c flashes for one second and then the current scan setting is displayed*

0 F F *Scan function off*

Press the up or down arrow to toggle the scan on or off.

0 n *Scan function on*

Press “SET” to accept the present setting and continue.



Accept scan setting

6.3.2 Scan Rate

The scan rate can be set from 0.1 to 99.9°C/min. The maximum scan rate, however, is actually limited by the natural heating or cooling rate of the instrument. This rate is often less than 100°C/min, especially when cooling.

The scan rate function appears in the main menu after the scan control function. The scan rate units are in degrees Celsius per minute, regardless of the selected units.

5 r *5 r flashes for one second and then the current scan rate setting is displayed*

0 . 1 *Scan rate in °C/min*

Press the up or down arrow to change the scan rate.

2 . 0 *New scan rate*

Press “SET” to accept the new scan rate and continue.



Accept scan rate

6.4 Set-point Resistance

This set-point resistance is used in the calibration calculation of the instrument and is not adjustable. Once the desired temperature has been reached and the controller is stable, the set-point resistance can be displayed by pressing “SET” and d simultaneously. The set-point resistance is displayed as follows.

5 r E 5 *5 r E 5 flashes for two seconds and then the whole number of the current set-point resistance setting is displayed*

99. Whole number portion of the set-point resistance flashes for two seconds and then the fraction portion of the current set-point resistance setting is displayed

.222 Fraction portion of the current set-point resistance setting

The set-point resistance is 99.222.

6.5 Secondary Menu

Functions which are used less often are accessed within the secondary menu. The secondary menu is accessed by pressing “SET” and “EXIT” simultaneously and then releasing. The first function in the secondary menu is the heater power display. (See Figure .)

6.6 Heater Power

The temperature controller controls the temperature of the well by pulsing the heater on and off. The total power being applied to the heater is determined by the duty cycle or the ratio of heater on time to the pulse cycle time. By knowing the amount of heating, the user can tell if the calibrator is heating up to the set-point, cooling down, or controlling at a constant temperature. Monitoring the percent heater power, allows the user to know the stability of the well temperature. With good control stability the percent heating power should not fluctuate more than $\pm 1\%$ within one minute.

The heater power display is accessed in the secondary menu. Press “SET” and “EXIT” simultaneously and release. The heater power is displayed as a percentage of full power.

100.0 C Well temperature

 +  Access heater power in secondary menu

SEC Flashes SEC for secondary menu and then displays the heater power

12.0P Heater power in percent

To exit out of the secondary menu press “EXIT”. To continue on to the proportional band setting function press “SET”.

6.7 Proportional Band

In a proportional controller such as this, the heater output power is proportional to the well temperature over a limited range of temperatures around the set-point. This range of temperature is called the proportional band. At the bottom of the proportional band, the heater output is 100%. At the top of the proportional band, the heater output is 0. Thus, as the temperature rises the heater power is reduced, which consequently tends

9100S Dry-Well Calibrator

Controller Configuration

to lower the temperature back down. In this way the temperature is maintained at a fairly constant level.

The temperature stability of the well and response time depend on the width of the proportional band. If the band is too wide, the well temperature deviates excessively from the set-point due to varying external conditions. This is because the power output changes very little with temperature and the controller cannot respond very well to changing conditions or noise in the system. If the proportional band is too narrow, the temperature may swing back and forth because the controller overreacts to temperature variations. For best control stability, the proportional band must be set for the optimum width.

The proportional band width is set at the factory and printed on the Report of Calibration. The proportional band width may be altered by the user if desired to optimize the control characteristics for a particular application.

The proportional band width is easily adjusted from the front panel. The width may be set to discrete values in degrees C or F depending on the selected units. The proportional band adjustment is accessed within the secondary menu. Press “SET” and “EXIT” to enter the secondary menu and show the heater power. Then press “SET” to access the proportional band.



Access heater power in secondary menu

5 E C

Flashes 5 E C for secondary menu and then displays the heater power

12.0 P

Heater power in percent



Access proportional band

P r o P

Flashes P r o P and then displays the setting

4.1

Proportional band setting

To change the proportional band press ▲ or ▼.

10.0

New proportional band setting

To accept the new setting press “SET”. Press “EXIT” to continue without storing the new value.



Accept the new proportional band setting

6.8 Controller Configuration

The controller has a number of configuration and operating options and calibration parameters which are programmable via the front panel. These are accessed from the secondary menu after the proportional band function by pressing “SET”. Pressing “SET” again enters the first of three sets of configuration parameters — operating

parameters, serial interface parameters, and calibration parameters. The menus are selected using the up and down arrows and then pressing “SET”.

6.9 Operating Parameters

The operating parameters menu is indicated by,

P A r *Operating parameters menu*

The operating parameters menu contains the High Limit parameter.

6.10 High Limit

The High Limit parameter adjusts the upper set-point temperature. The factory default and maximum are set to 375°C (707°F). The minimum setting is 125°C (257°F). For safety, a user can adjust the High Limit down so the maximum temperature set-point is restricted.

H L *Flashes H L and then displays the setting*

3 7 5 *Flashes the current value and then displays the value for adjustment*

3 7 5 *Current High Limit setting*

Press the ▲ or ▼ to adjust the setting.

3 0 0 *New High Limit setting*

To accept the new setting, press “SET”. Press “EXIT” to continue without storing the new value.



Accept the new High Limit setting

6.11 Serial Interface Parameters

The serial RS-232 interface parameters menu is indicated by,

S E r L *Serial RS-232 interface parameters menu*

Press “SET” to enter the menu. The serial interface parameters menu contains parameters which determine the operation of the serial interface. The parameters in the menu are — baud rate, sample period, duplex mode, and linefeed.

6.11.1 Baud Rate

The baud rate is the first parameter in the menu. The baud rate setting determines the serial communications transmission rate.

The baud rate parameter is indicated by,

9100S Dry-Well Calibrator

Serial Interface Parameters

b R U d *Flashes b R U d for one second and then displays the setting*

2 4 0 0 b *Current baud rate*

The baud rate of the serial communications may be programmed to 300, 600, 1200, 2400 (default), 4800, or 9600 baud. Use the up or down arrows to change the baud rate value.

4 8 0 0 b *New baud rate*

Press “SET” to accept the new setting or “EXIT” to abort the operation and skip to the next parameter in the menu.

6.11.2 Sample Period

The sample period is the next parameter in the serial interface parameter menu. The sample period is the time period in seconds between temperature measurements transmitted from the serial interface. If the sample rate is set to 5, the instrument transmits the current measurement over the serial interface approximately every five seconds. The automatic sampling is disabled with a sample period of 0. The sample period is indicated by,

S P E r *Flashes for one second and then the serial sample period setting is displayed*

l *Current sample period (seconds)*

Adjust the value by using the up or down arrows (▲ ▼).

5 0 *New sample period*

Press “SET” to accept the new setting or “EXIT” to abort the operation and skip to the next parameter in the menu.

6.11.3 Duplex Mode

The next parameter is the duplex mode. The duplex mode may be set to full duplex or half duplex. With full duplex any commands received by the calibrator via the serial interface are immediately echoed or transmitted back to the device of origin. With half duplex the commands are executed but not echoed. The duplex mode parameter is indicated by,

d U P L *Flashes for one second and then the serial duplex mode setting is displayed*

F U L L *Current duplex mode setting*

The mode may be changed using the up or down arrows (▲ ▼).

H R L F *New duplex mode setting*

Press “SET” to accept the new setting or “EXIT” to abort the operation and skip to the next parameter in the menu.

6.11.4 Linefeed

The final parameter in the serial interface menu is the linefeed mode. This parameter enables (on) or disables (off) transmission of a linefeed character (LF, ASCII 10) after transmission of any carriage-return. The linefeed parameter is indicated by,

L F *Flashes for one second and then the serial linefeed setting is displayed*

U n *Current linefeed setting*

The mode may be changed using the up or down arrows (u d).

O F F *New linefeed setting*

Press “SET” to accept the new setting or “EXIT” to abort the operation and skip to the next parameter in the menu.

6.12 Calibration Parameters

The operator of the instrument controller has access to a number of the calibration constants namely the Hard Cutout, R0, ALPHA, and DELTA. These values are set at the factory and must not be altered. The correct values are important to the accuracy and proper and safe operation of the instrument. Access to these parameters is available to the user so in the event the controller memory fails the user may restore these values to the factory settings. The user should have a list of these constants and their settings with the instrument manual.



CAUTION: *DO NOT change the values of the instrument calibration constants from the factory set values. The correct setting of these parameters is important to the safety, proper operation, and performance of the instrument.*

The calibration parameters menu is indicated by,

C R L *Calibration parameters menu*

Press “SET” five times to enter the menu. The calibration parameters menu contains the parameters, Hard Cutout, R0, ALPHA, and DELTA, which characterize the resistance-temperature relationship of the platinum control sensor. These parameters may be adjusted to improve the accuracy of the calibrator.

The calibration parameters are accessed by pressing “SET” after the name of the parameter is displayed. The value of the parameter may be changed using the up or down arrow. After the desired value is reached, press “SET” to set the parameter to the

9100S Dry-Well Calibrator

Calibration Parameters

new value. Pressing “EXIT” causes the parameter to be skipped ignoring any changes that may have been made.

7.12.1

6.12.1 Hard Cutout

This parameter is the temperature above which the unit shuts down automatically. The value of this parameter is set at the factory to approximately 400°C and cannot be changed by the user.

The hard cutout parameter is indicated by,

ⒻⒻⒻⒻⒻ *Flashes for one second and then the hard cutout setting is displayed*

400.0 *Current hard cutout setting*

Press “EXIT” to continue to the next parameter.

6.12.2 R0

This probe parameter refers to the resistance of the control probe at 0°C. The value of this parameter is set at the factory for best instrument accuracy. The value ranges from 95 to 105. For values greater than 100.000, the display does not show the hundreds placement. For values less than 100.000, the display shows the entire value. The R0 parameter is indicated by,

ⒻⒻ *Flashes for one second and then the R0 setting is displayed*

00.014 *Current R0 setting (100.014)*

To change the R0 setting, press the up or down arrows.

99.999 *New R0 setting*

To accept the new setting, press “SET”. Press “EXIT” to continue without storing the new value.

 *Accept the new R0 setting*

6.12.3 ALPHA

This probe parameter refers to the average sensitivity of the probe between 0 and 100°C. The value of this parameter is set at the factory for best instrument accuracy.

ⒶⒻⒻⒶ *Flashes for one second and then the ALPHA setting is displayed*

38530 *Current ALPHA setting*

To change the ALPHA setting, press the up or down arrows.

38600 *New ALPHA setting*

To accept the new setting, press “SET”. Press “EXIT” to continue without storing the new value.



Accept the new ALPHA setting

6.12.4 DELTA

This probe parameter characterizes the curvature of the resistance-temperature relationship of the sensor. The value of this parameter is set at the factory for best instrument accuracy.

DELTA *Flashes for one second and then the DELTA setting is displayed*

0.0000 *Current DELTA setting*

To change the DELTA setting, press the up or down arrows.

0.1000 *New DELTA setting*

To accept the new setting, press “SET”. Press “EXIT” to continue without storing the new value.



Accept the new DELTA setting

7 Digital Communication Interface

This instrument is capable of communicating with and being controlled by other equipment through the digital serial interface.

With a digital interface, the instrument may be connected to a computer or other equipment. This allows the user to set the set-point temperature, monitor the temperature, and access any of the other controller functions, all using remote communications equipment. Communications commands are summarized in Table 2 on next page.

7.1 RS-232 Connection

The three-conductor jack for the serial port is located on the back of the instrument. One serial cable is included. Additional or longer cables, of three meters or less, can be constructed by following the wiring diagram shown in Figure . Note: The Tx/D line on one side connects to the Rx/D line on the other and vice-versa. To reduce the possibility of electrical interference, the serial cable should be shielded with low resistance between the connector and the shield and should not be much longer than is necessary. The protocol for serial communications is 8 data bits, 1 stop bit, and no parity. Use no flow control. Set the linefeed to ON (all carriage returns are followed by a linefeed (ASCII decimal 10)), and the duplex to HALF, disabling echo.

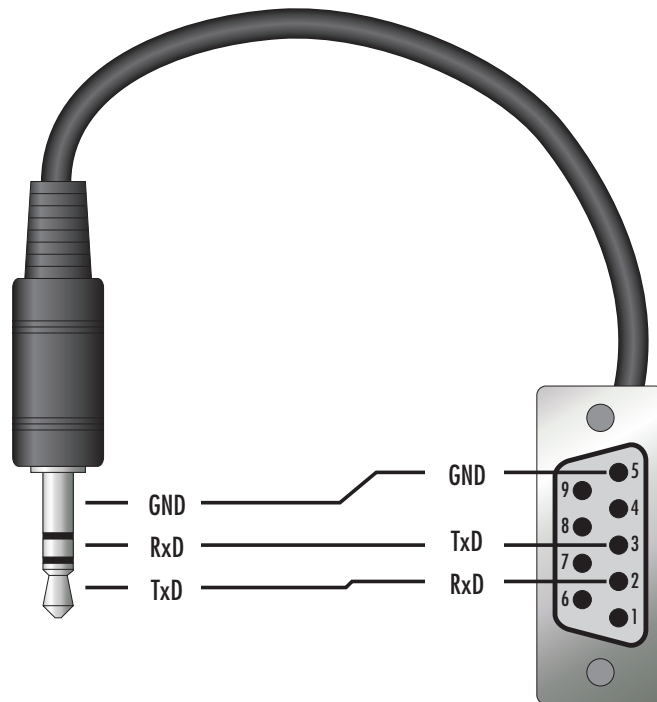

Figure 6 Serial cable wiring

9100S Dry-Well Calibrator

Interface Commands

The serial port can be used to transmit measurements to a computer or printer or to change settings of the instrument from a computer. A full list of commands follows in Section .

Commands sent to the instrument must end with an EOS character which is a carriage return (CR, ASCII 13) or linefeed character (LF, ASCII 10). Commands can be sent with upper or lower case letters. Data returned from the instrument ends with a carriage return. If the linefeed setting is on, a linefeed character is also sent after the carriage return.

7.2 Interface Commands

The various commands for accessing the calibrator functions via the digital interface are listed in this section (see Table). These commands are used with the RS-232 serial interface. The commands are terminated with a carriage-return character (CR, ASCII 13). The interface makes no distinction between upper and lower case letters, hence either may be used. Commands may be abbreviated to the minimum number of letters which determines a unique command. A command may be used to either set a parameter or display a parameter depending on whether or not a value is sent with the command following a “=” character. For example “s” returns the current set-point and “s=150.0” sets the set-point to 150.0 degrees.

In the following list of commands, characters or data within brackets, “[” and “]”, are optional for the command. A slash, “/”, denotes alternate characters or data. Numeric data, denoted by “n”, may be entered in decimal or exponential notation. Characters are shown in lower case although upper case may be used. Spaces may be added within command strings and will simply be ignored. Backspace (BS, ASCII 8) may be used to erase the previous character. A terminating (CR, ASCII 13) is implied with all commands.

Table 2 Controller communications commands

Command Description	Command Format	Command Example	Returned	Returned Example	Acceptable Values
Display Temperature					
Read current set-point	s[etpoint]	s	set: 9999.99 {C or F}	set: 150.00 C	
Set current set-point to <i>n</i>	s[etpoint]= <i>n</i> or t[emperature]= <i>n</i>	s=350 t=350			Instrument Range
Read temperature	t[emperature]	t	t: 9999.9 {C or F}	t: 55.6 C	
Read temperature units	u[nits]	u	u: x	u: C	
Set temperature units:	u[nits]=c/f				C or F
Set temperature units to Celsius	u[nits]=c	u=c			
Set temperature units to Fahrenheit	u[nits]=f	u=f			
Read scan mode	sc[an]	sc	sc: {ON or OFF}	sc: ON	
Set scan mode	sc[an]=on/off	sc=on			ON or OFF
Read scan rate	sr[ate]	sr	srat: 99.9 {C or F}/min	srat:12.4 C/min	
Set scan rate	sr[ate]= <i>n</i>	sr=1.1			0.1 to 99.9°C 0.2 to 179.8°F

Digital Communication Interface

Interface Commands

Command Description	Command Format	Command Example	Returned	Returned Example	Acceptable Values
Secondary Menu					
Read proportional band setting	pr[op-band]	pr	pb: 999.9	pb: 15.9	
Set proportional band to <i>n</i>	pr[op-band]= <i>n</i>	pr=8.83			0.1 to 30°C 0.2 to 54°F
Read heater power (duty cycle)	po[wer]	po	po: 999.9	po: 6.5	
Configuration Menu					
Operating Parameters Menu					
Read High Limit	hl[imit]	hl	hl: 9999.9	hl: 375.0	
Set High Limit	hl[imit]= <i>n</i>	hl=300			125.0 to 375.0°C 257.0 to 707°F
Serial Interface Menu					
Read serial sample setting	sa[mple]	sa	sa: 99999	sa: 1	
Set serial sampling setting to <i>n</i> seconds	sa[mple]= <i>n</i>	sa=0			0 to 10,000
Set serial duplex mode:	du[plex]=f[ull]/h[alf]				FULL or HALF
Set serial duplex mode to full	du[plex]=f[ull]	du=f			
Set serial duplex mode to half	du[plex]=h[alf]	du=h			
Set serial linefeed mode:	lf[eed]=on/of[f]				ON or OFF
Set serial linefeed mode to on	lf[eed]=on	lf=on			
Set serial linefeed mode to off	lf[eed]=of[f]	lf=of			
Calibration Menu					
Read R0 calibration parameter	r[0]	r	r0: 999.999	r0: 100.7	
Set R0 calibration parameter to <i>n</i>	r[0]= <i>n</i>	r=100.7			95.0 to 105.0
Read ALPHA calibration parameter	al[pha]	al	al: 9.99999999	al: 0.003865	
Set ALPHA calibration parameter to <i>n</i>	al[pha]= <i>n</i>	al=0.003865			0.002 to 0.006
Read DELTA calibration parameter	de[lta]	de		de: 1.50	
Set DELTA calibration parameter	de[lta]= <i>n</i>	de=1.37	de: 9.99999		0–3.0
Miscellaneous Other Commands					
Read firmware version number	*ver[sion]	*ver	ver.9999x,9.99	ver.9100S,1.01	
Read structure of all commands	h[elp]	h	list of commands		
Read ALL operating parameters	all	all	list of parameters		
Read setpoint resistance	*sr	*sr	999.999 ohms	110.023 ohms	

Legend: [] Optional command data
 {} Returns either information
 n Numeric data supplied by user
 9 Numeric data returned by user
 x Character data returned to user

Note: When DUPLEX is set to FULL and a command is sent to READ, the command is returned followed by a carriage return and linefeed. Then the value is returned as indicated in the RETURNED column.

8 Test Probe Calibration

For optimum accuracy and stability, allow the calibrator to warm up for 10 minutes after power-up and then allow adequate stabilization time after reaching the set-point temperature. After completing operation of the calibrator, allow the well to cool by setting the temperature to 25°C for one-half hour before switching the power off.

8.1 Calibrating a Single Probe

Insert the probe to be calibrated into the well of the instrument. The probe should fit snugly into the calibrator probe sleeve yet should not be so tight that it cannot be easily removed. Avoid any dirt or grit that may cause the probe to bind in the sleeve. Best results are obtained with the probe inserted to the full depth of the well. Once the probe is inserted into the well, allow adequate stabilization time to allow the test probe temperature to settle as described above. Once the probe has settled to the temperature of the well, it may be compared to the calibrator display temperature. The display temperature should be stable to within 0.1°C degree for best results.



CAUTION: *Never allow foreign material into the probe holes of the block. Fluids and other materials can damage the instrument causing binding and damage to your probe.*

8.2 Dry-well Characteristics

There is a temperature gradient vertically in the test well. The heater has been applied to the block in such a way as to compensate for nominal heat losses out of the top of the dry-well. However, actual heat losses vary with design of the thermometer probes inserted into the calibrator and the temperature. For best results, insert probe to full depth of well.

8.2.1 Stabilization and Accuracy

The stabilization time of the instrument depends on the conditions and temperatures involved. Typically, the test well stabilizes to 0.1°C within 5 minutes of reaching the set-point temperature as indicated by the display. Ultimate stability is achieved 10 to 20 minutes after reaching the set temperature.

Inserting a cold probe into a warm well requires another period of stabilizing depending on the magnitude of the disturbance and the required accuracy. For example, inserting a 0.25 inch diameter room temperature probe into a sleeve at 300°C takes 5 minutes to be within 0.3°C of its settled point and might take 10 minutes to achieve maximum stability.

Speeding up the calibration process can be accomplished by knowing how soon to make the measurement. It is recommended that typical measurements be made at the desired temperatures with the desired test probes to establish these times.

9 Calibration Procedure



Note: This procedure is to be considered a general guideline. Each laboratory should write their own procedure based on their equipment and their quality program. Each procedure should be accompanied by an uncertainty analysis also based on the laboratory's equipment and environment.

Sometimes the user may want to calibrate the dry-well to improve the temperature set-point accuracy. Calibration is done by adjusting the controller probe calibration constants R0, ALPHA, and DELTA so that the temperature of the dry-well as measured with a standard thermometer agrees more closely with the set-point. The thermometer used must be able to measure the well temperature with higher accuracy than the desired accuracy of the dry-well. By using a good thermometer and following this procedure the dry-well can be calibrated to an accuracy of better than 0.5°C over its full range.

9.1 Calibration Points

In calibrating the dry-well, R0, ALPHA, and DELTA are adjusted to minimize the set-point error at each of three different dry-well temperatures. Any three reasonably separated temperatures may be used for the calibration. Improved results can be obtained for shorter ranges when using temperatures that are just within the most useful operating range of the dry-well. The farther apart the calibration temperatures, the greater the calibrated temperature range. However, the calibration error is also greater over the range. For instance, if 150°C to 350°C is chosen as the calibration range, the calibrator may achieve an accuracy of say $\pm 0.3^\circ\text{C}$ over the range 150°C to 350°C. Choosing a range of 200°C to 300°C may allow the calibrator to have a better accuracy of maybe $\pm 0.2^\circ\text{C}$ over the range 175°C to 325°C but outside that range the accuracy may be only $\pm 0.5^\circ\text{C}$.

9.2 Calibration Procedure

1. Choose three set points to use in the calibration of the R0, ALPHA, and DELTA parameters. These set points are generally 50.0°C, 200°C, and 350.0°C but other set points may be used if desired or necessary.
2. Set the dry-well to the lowest set-point. When the dry-well reaches the set-point and the display is stable, wait 15 minutes or so and then take a reading from the thermometer (T_1). Sample the set-point resistance of the dry-well (R_1) by holding down "SET" and pressing d. Write these values down as T_1 and R_1 respectively.
3. Repeat step 2 for the other two set-points recording them as T_2 and R_2 and T_3 and R_3 respectively.
4. Using this recorded data, calculate new values for R0, ALPHA, and DELTA using the following formula:

9100S Dry-Well Calibrator

Calibration Procedure

9.2.1 Compute DELTA

$$A = T_3 - T_2$$

$$B = T_2 - T_1$$

$$C = \left[\frac{T_3}{100} \right] \left[1 - \frac{T_3}{100} \right] - \left[\frac{T_2}{100} \right] \left[1 - \frac{T_2}{100} \right]$$

$$D = \left[\frac{T_2}{100} \right] \left[1 - \frac{T_2}{100} \right] - \left[\frac{T_1}{100} \right] \left[1 - \frac{T_1}{100} \right]$$

$$E = R_3 - T_2$$

$$F = R_2 - T_1$$

$$\text{delta} = \frac{AF - BE}{DE - CF}$$

where:

T_1 and R_1 are the measured temperature and set-point resistance at 50.0 °C

T_2 and R_2 are the measured temperature and set-point resistance at 200.0 °C

T_3 and R_3 are the measured temperature and set-point resistance at 350.0 °C

9.2.2 Compute R0 and ALPHA

$$a_1 = T_1 + \text{delta} \left[\frac{T_1}{100} \right] \left[1 - \frac{T_1}{100} \right]$$

$$a_3 = T_3 + \text{delta} \left[\frac{T_3}{100} \right] \left[1 - \frac{T_3}{100} \right]$$

$$\text{rzero} = \frac{R_3 a_1 - R_1 a_3}{a_1 - a_3}$$

$$\text{alpha} = \frac{R_1 - R_3}{R_3 a_1 - R_1 a_3}$$

delta is the new value of DELTA computed above (Section)

Program the new values for DELTA (delta), R0 (rzero), and ALPHA (alpha) into the instrument (see Section 6.12, Calibration Parameters on page 27 and Figure 5 on page 21).

9.2.3 Accuracy and Repeatability

Check the accuracy of the dry-well at various points over the calibration range. If dry-well does not pass specification at all set-points, repeat the Calibration Procedure.

10 Maintenance

- This instrument has been designed with the utmost care. Ease of operation and simplicity of maintenance have been a central theme in the product development. Therefore, with proper care the instrument should require very little maintenance. Avoid operating the instrument in an oily, wet, dirty, or dusty environment.
- If the outside of the instrument becomes soiled, it may be wiped clean with a damp cloth and mild detergent. Do not use harsh chemicals on the surface which may damage the paint.
- It is important to keep the well of the calibrator clean and clear of any foreign matter. Do not use fluid to clean out the well.
- Use a commercially available plastic or felt brush, of appropriate diameter for a tight fit without any fluid, to clean the well. Complete the cleaning process by using cotton swabs and air to remove any debris.
- The dry-well calibrator should be handled with care. Avoid knocking or dropping the calibrator.
- Do not slam the probe stems into the well. This type of action can cause a shock to the sensor.
- If a hazardous material is spilt on or inside the equipment, the user is responsible for taking the appropriate decontamination steps as outlined by the national safety council with respect to the material.
- If the mains supply cord becomes damaged, replace it with a cord with the appropriate gauge wire for the current of the instrument. If there are any questions, call a Fluke Authorized Service Center for more information.
- Before using any cleaning or decontamination method except those recommended by Fluke, users should check with an Authorized Service Center (see Section 1.4, Authorized Service Centers on page 5) to be sure that the proposed method will not damage the equipment.
- If the instrument is used in a manner not in accordance with the equipment design, the operation of the dry-well may be impaired or safety hazards may arise, and the warranty may be voided.

11 Troubleshooting

This section contains information on troubleshooting, CE Comments, and a wiring diagram.

11.1 Troubleshooting Problems, Possible Causes, and Solutions

In the event that the instrument appears to function abnormally, this section may help to find and solve the problem. Several possible problem conditions are described along with likely causes and solutions. If a problem arises, please read this section carefully and attempt to understand and solve the problem. If the problem cannot otherwise be solved, contact an Authorized Service Center (see Section 1.4, Authorized Service Centers on page 5) for assistance. Be sure to have the instrument's model number, serial number, voltage, and problem description available.

Problem	Possible Causes and Solutions
Incorrect temperature reading	<p>Incorrect R0, ALPHA, and DELTA parameters. Find the value for R0, ALPHA, and DELTA on the Report of Calibration. Reprogram the parameters into the instrument (see Section , Calibration Parameters). Allow the instrument to stabilize and verify the accuracy of the temperature reading.</p> <p>Controller locked up. The controller may have locked up due to a power surge or other aberration. Initialize the system by performing the Factory Reset Sequence.</p> <p>Factory Reset Sequence. Hold the SET and EXIT buttons down at the same time while powering up the instrument. The instrument displays shows '-init-'; the model number, and the firmware version. Each of the controller parameters and calibration constants must be reprogrammed. The values can be found on the Report of Calibration.</p>
The instrument heats or cools too quickly or too slowly	<p>Incorrect scan and scan rate settings. The scan and scan rate settings may be set to unwanted values. Check the Scan and Scan Rate settings. The scan may be off (if the unit seems to be responding too quickly). The scan may be on with the Scan Rate set low (if unit seems to be responding too slowly).</p> <p>Improper line voltage. Verify that the voltage reading in the bottom of the unit matches the source voltage.</p>
Unstable display	<p>Wait. Allow the instrument to stabilize for a few minutes.</p> <p>Proportional band may be incorrect. Refer to the proportional band on the Report of Calibration.</p>
The display shows any of the following: Err 1 . Err 2 . Err 3 . Err 4 . Err 5. Err 6. or Err 7	<p>Controller problem. The error messages signify the following problems with the controller.</p> <p>Err 1 - a RAM error Err 2 - a NVRAM error Err 3 - a Structure error Err 4 - an ADC setup error Err 5 - an ADC ready error Err 6 - a defective control sensor Err 7 - a heater error</p> <p>Initialize the system by performing the Factory Reset Sequence describe above.</p>
Temperature cannot be set above a certain point	<p>Incorrect High Limit parameter. The High Limit parameter may be set below 375°C. Check this value as described in Section 6.9, Operating Parameters on page 25.</p>

11.2 CE Comments

11.2.1 EMC Directive

Fluke's equipment has been tested to meet the European Electromagnetic Compatibility Directive (EMC Directive, 89/336/EEC). The Declaration of Conformity for your instrument lists the specific standards to which the unit was tested.

11.2.2 Low Voltage Directive (Safety)

In order to comply with the European Low Voltage Directive (73/23/EEC), Fluke equipment has been designed to meet the IEC 1010-1 (EN 61010-1) and the IEC 1010-2-010 (EN 61010-2-010) standards.