



INSTRUMENTS

T2A Operator's Manual

Part Number: 71-0529

Revision: P9

Released: 3/25/21



WARNING

Read and understand this instruction manual before operating detector. Improper use of the detector could result in bodily harm or death.

Periodic calibration and maintenance of the detector is essential for proper operation and correct readings. Please calibrate and maintain this detector regularly! Frequency of calibration depends upon the type of use you have and the sensor types. Typical calibration frequencies for most applications are between 1 and 3 months, but can be required more often or less often based on your usage.

Product Warranty

RKI Instruments, Inc. warrants gas alarm equipment sold by us to be free from defects in materials, workmanship, and performance for a period of one year from date of shipment from RKI Instruments, Inc. Any parts found defective within that period will be repaired or replaced, at our option, free of charge. This warranty does not apply to those items which by their nature are subject to deterioration or consumption in normal service, and which must be cleaned, repaired, or replaced on a routine basis. Examples of such items are:

- a) Absorbent cartridges
- b) Pump diaphragms and valves
- c) Fuses
- d) Batteries
- e) Filter elements

Warranty is voided by abuse including mechanical damage, alteration, rough handling, or repair procedures not in accordance with the operator's manual. This warranty indicates the full extent of our liability, and we are not responsible for removal or replacement costs, local repair costs, transportation costs, or contingent expenses incurred without our prior approval.

THIS WARRANTY IS EXPRESSLY IN LIEU OF ANY AND ALL OTHER WARRANTIES AND REPRESENTATIONS, EXPRESSED OR IMPLIED, AND ALL OTHER OBLIGATIONS OR LIABILITIES ON THE PART OF RKI INSTRUMENTS, INC. INCLUDING BUT NOT LIMITED TO, THE WARRANTY OF MERCHANTABILITY OR FITNESS FOR A PARTICULAR PURPOSE. IN NO EVENT SHALL RKI INSTRUMENTS, INC. BE LIABLE FOR INDIRECT, INCIDENTAL, OR CONSEQUENTIAL LOSS OR DAMAGE OF ANY KIND CONNECTED WITH THE USE OF ITS PRODUCTS OR FAILURE OF ITS PRODUCTS TO FUNCTION OR OPERATE PROPERLY.

This warranty covers instruments and parts sold to users by authorized distributors, dealers, and representatives as appointed by RKI Instruments, Inc.

We do not assume indemnification for any accident or damage caused by the operation of this gas monitor, and our warranty is limited to the replacement of parts or our complete goods.

Warning Statements

The RKI Instruments, Inc. T2A Toxic Gas Monitor is Class I Division 1 Certified. The assembly is able to maintain its certification at all times while in the field, simply by using the non-intrusive calibration method which requires the use of an RKI-distributed magnet. However, if the Moore lid is removed, for whatever reason, the T2A's certification is no longer valid.

To avoid invalidating the certification, complete all wiring configurations *BEFORE* putting the T2A in the field. Once in the field, always use the RKI-distributed magnet to ensure non-intrusive calibration.

Strong magnetic fields may interfere with the non-intrusive magnetic switches. A strong magnetic field may momentarily active a switch, or permanently disable the switch to the "on" or "off" position.

Do not cover the hole in the calibration cup, as this will cause the calibration to be inaccurate.

Danger Statements

DANGER: The RKI Instruments Inc. T2A is an ambient air Hazardous gas sensor assembly and only monitors in the immediate vicinity of the sensor housing. A site survey is required in order to determine the best placement and quantity of sensor assemblies. Improper installation can lead to an undetectable gas leak which could result in personal injury or loss of life.

Table of Contents

Overview	7
Specifications	8
External Description	10
Internal Description	11
Exploded Drawing	12
Remote-Mounted Kit	13
Installation	13
Mounting the T2A	13
Remote-Mounted Kit Wiring	16
Wiring Power and 4-20 mA Output	17
Closing the Enclosure	18
Start Up	19
Operation	21
Normal Operating Mode	21
Magnetic Buttons	22
Powering the Device	22
Faults	23
Accessing Menus	23
Product Settings and Configuration	24
Entering the Product Settings and Configuration Menu	24
Alarm Test	24
System Information	25
Zero/Calibration Timer Information	26
Calibration Method	26
4-20 mA Offset Settings	27
Display Screen Contrast Setting	28
Return to Factory Default Settings	29
Reset Zero & Calibration Values	30
Maintenance	31
Troubleshooting	32
Desiccant Replacement	32
Sensor Replacement	33

Calibration	35
Calibration Frequency	35
Materials.....	35
Zeroing the Sensor.....	36
Calibrating the Sensor (Manual Cal)	37
Calibrating the Sensor (Auto Cal)	39
Parts List	42
Appendix A: 4-20 mA Signal	44



Overview

The RKI Instruments, Inc. T2A Explosion-Proof Ambient Air Hazardous Gas Detector is designed to detect a wide range of toxic gases in potentially hazardous environments. This product's enclosure is QPS certified as Class I, Division 1, Groups B, C, and D and rated for Class I, Zone 1, Group IIB. The T2A features non-intrusive magnetic switches that allow for complete system configuration, regular calibration, and product maintenance to be performed in the field, without opening the enclosure and breaking the seal of the enclosure, thereby compromising the explosion-proof rating of the device. Non-intrusive interface with the T2A is made possible by use of the magnetic tool included in the purchase of the device. The T2A display screen will always show the present concentration of gas being detected by the sensor assembly.

This document is an operation manual containing diagrams and step-by-step instructions for the proper and safe installation, start-up, configuration and settings, normal operation, and product maintenance of the T2A.

In this manual, the instructions reference the use of push-buttons, located on the front panel of the device. In certain environments, the activation of the non-intrusive magnetic switches, through the use of the magnetic tool, will replace the directive of the button-press actions. To apply the magnetic tool, hold the tool to the side of the device enclosure adjacent to the push-button that you wish to activate. When the magnetic switch is toggled, an on-screen indicator will appear on the display screen, signifying that a connection was made.

NOTE: This document should be read in its entirety before the initial operation of the product.

Specifications

Table 1 lists specifications for the T2A.

Table 1: Specifications



Target Gas	Detection Range	Increments	Haz. Loc.
Ammonia	0-100 ppm	1 ppm	Cl. 1 Div. 2
	0-200 ppm		
	0-400 ppm		
Carbon Monoxide	0-300 ppm		Cl. 1 Div. 1
Chlorine	0-3.0 ppm	0.1 ppm	Cl. 1 Div. 2
	0-10.0 ppm		
	0-20.0 ppm		
Chlorine Dioxide	0-1.00 ppm	0.01 ppm	
	0-5.0 ppm	0.1 ppm	
Hydrogen Chloride	0-15 ppm	1 ppm	Cl. 1 Div. 1
Hydrogen Cyanide	0-30 ppm		
Hydrogen Fluoride	0-10.0 ppm	0.1 ppm	Cl. 1 Div. 2
Hydrogen Sulfide	0-100 ppm	1 ppm	Cl. 1 Div. 1
Nitric Oxide	0-250 ppm		Cl. 1 Div. 2
Nitrogen Dioxide	0-20.0 ppm	0.1 ppm	
Oxygen	0-25.0%	0.1% volume	
Ozone	0-100 ppm	1 ppm	
Phosphine	0-5.0 ppm	0.1 ppm	Cl. 1 Div. 1
Sulfur Dioxide	0-20 ppm	1 ppm	
Sampling Method			
		Diffusion	
Enclosure Ratings			
		Explosion/Flame-Proof	
Junction Box Hazardous Location Certification			
		Class I, Division 1, Groups B, C, D Ex db IIB Gb Class I, Zone 1, AEx db IIB Gb	
			
Sensor Housing Hazardous Location Certification			
		Class I, Division 1 (or Division 2), Groups B, C, D Ex db IIB Gb <i>NOTE: Certification only applies to some gases. Toxic gases not certified for Div. 1 locations are suitable for Div. 2 applications but have no third party approval.</i>	
			
Operating Voltage			
		12 - 35 VDC	

Table 1: Specifications

Maximum Current Draw	35 mA
Operating Temperature Range	-40°C to +60°C (-40°F to +140°F)
Humidity Range	0 - 98% relative humidity, non-condensing
Signal Output	4 to 20 mA (2-wire)
Enclosure Material	Aluminum
Sensor Housing Material	303 Stainless steel
Max Cable Length for Remote-Mounted Kit	250 feet
Dimensions	5.5" D x 6" W x 7" H
Weight	6 lbs.

WARNING: When using the T2A, you must follow the instructions and warnings in this manual to assure proper and safe operation of the T2A and to minimize the risk of personal injury. Be sure to maintain and periodically calibrate the T2A as described in this manual.

External Description

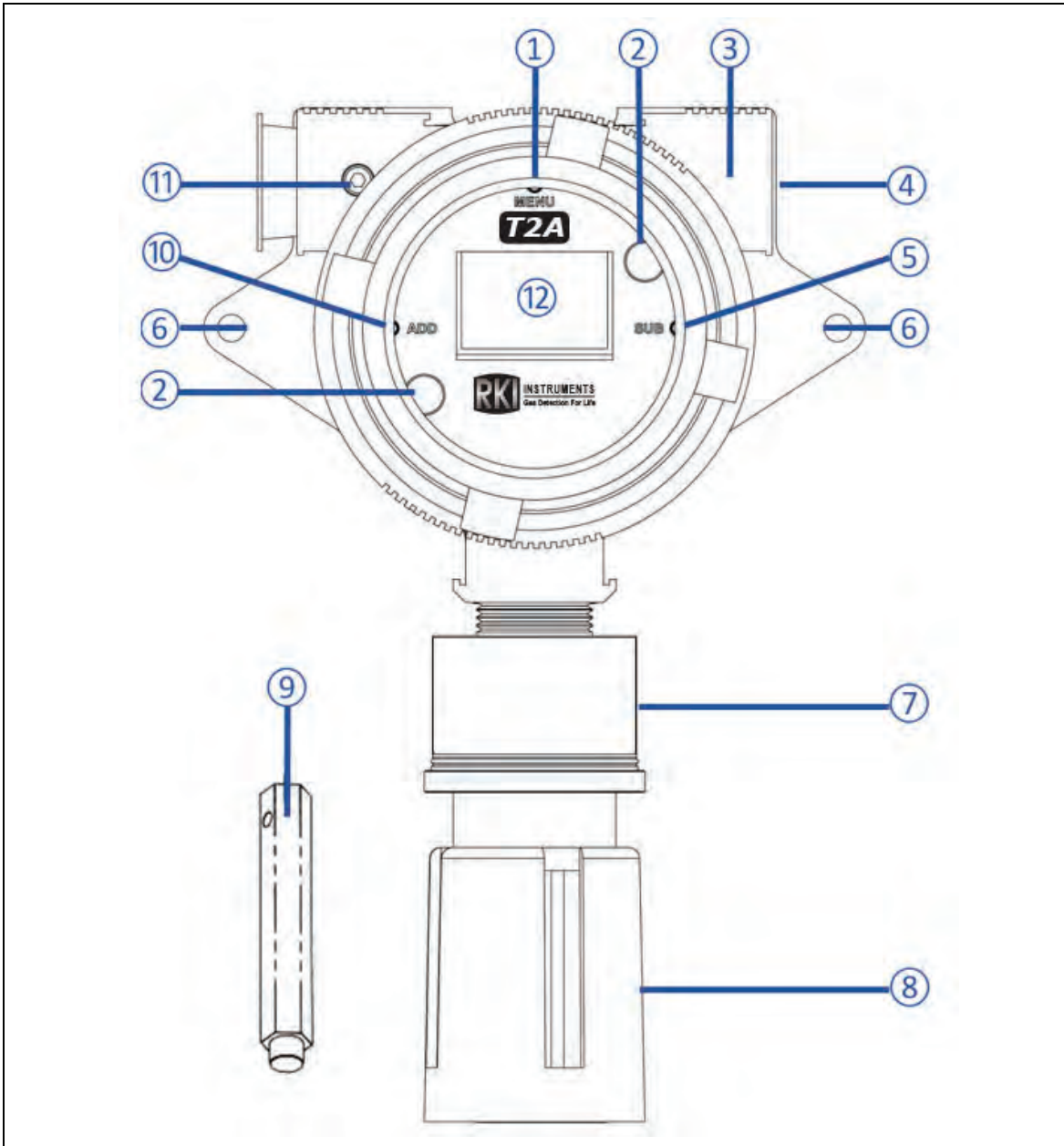

Figure 1: T2A External Component Location

1	MENU button
2	Front panel thumbscrew
3	Enclosure
4	Explosion proof plug
5	SUB button
6	Mounting hole

7	Sensor housing assembly
8	Rain guard
9	Magnetic tool
10	ADD button
11	Enclosure lid locking screw
12	Display screen

Internal Description

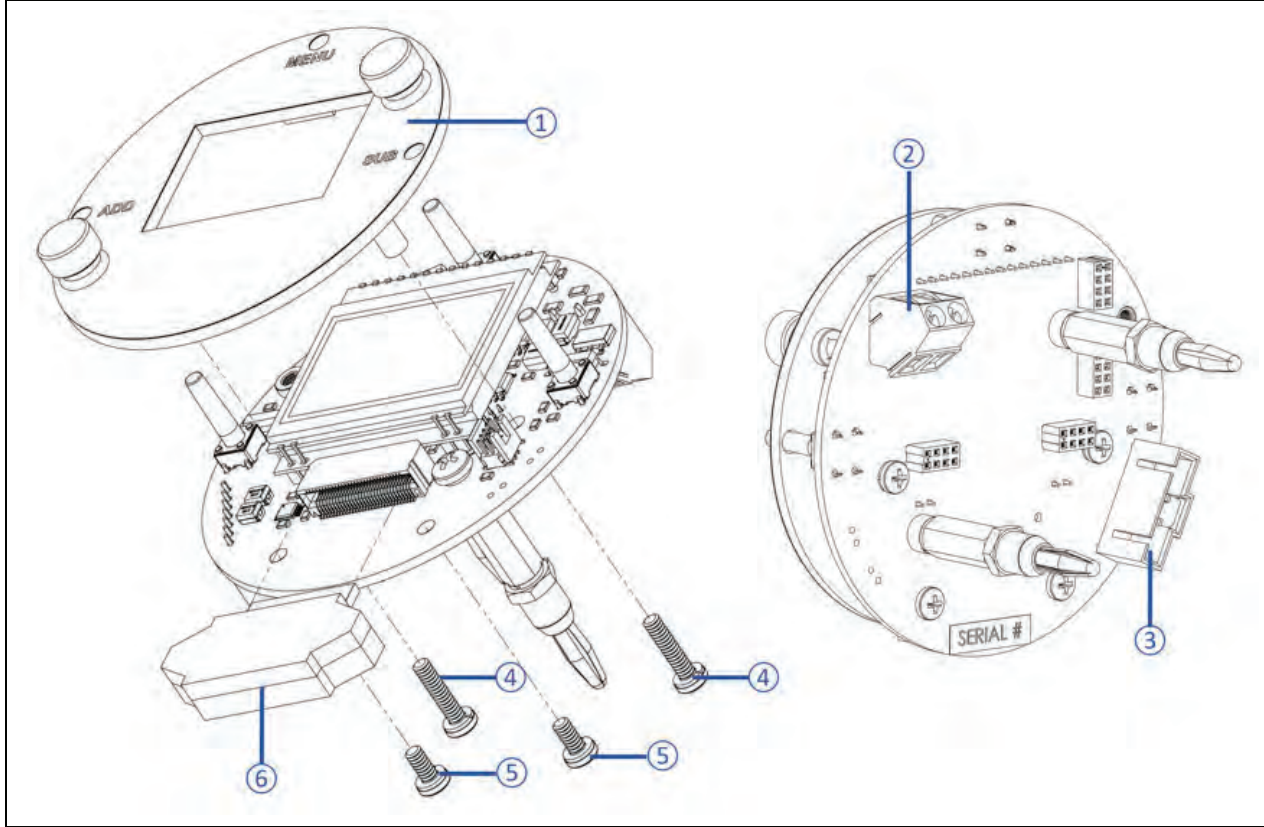

Figure 2: Internal Component Location

1	Faceplate assembly
2	Power input/4-20 mA output terminal block
3	Sensor housing socket

4	Faceplate mounting screws
5	Microcontroller module mounting screws
6	Microcontroller module

Exploded Drawing

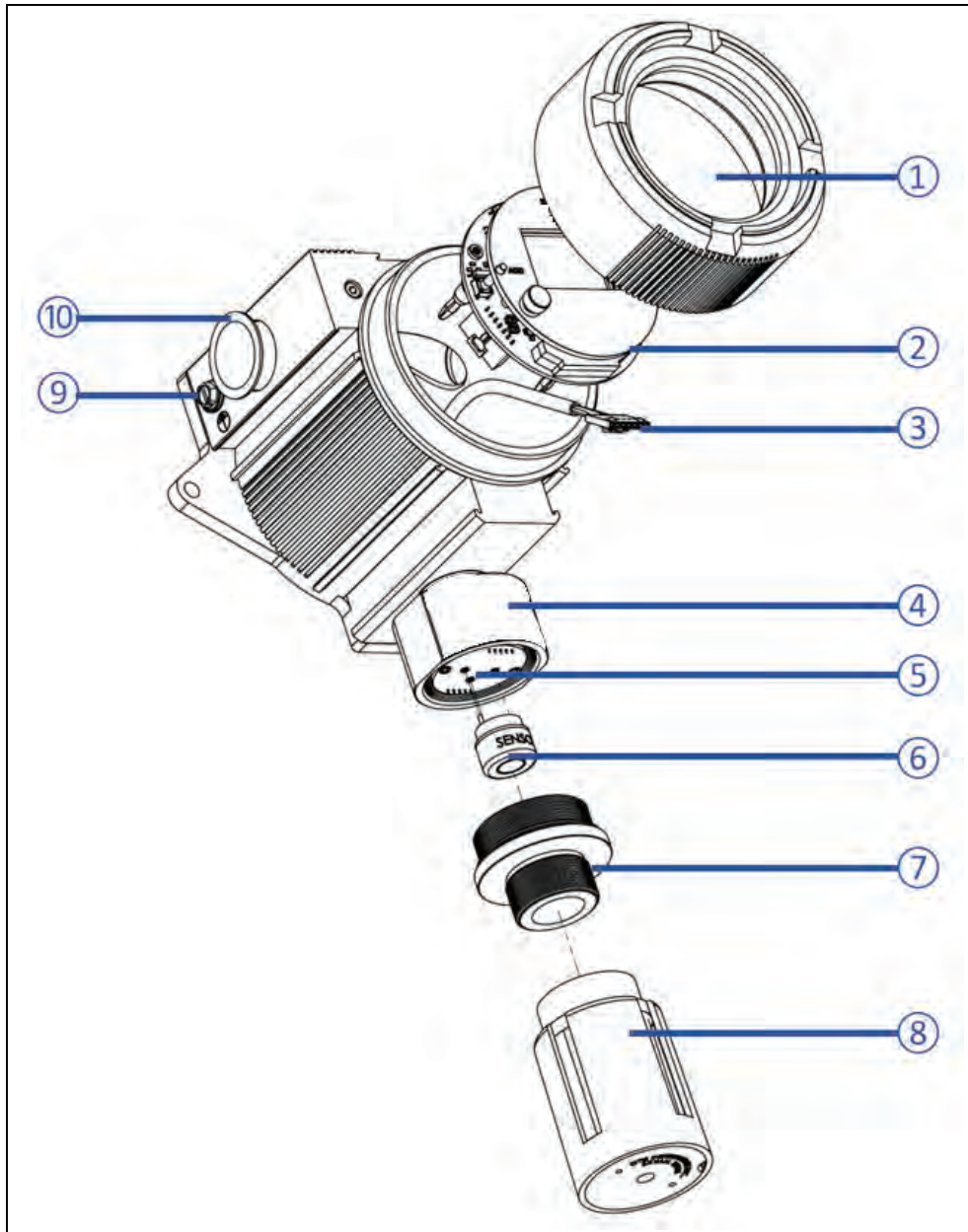

Figure 3: Exploded Drawing

1	Enclosure lid
2	Internal system
3	Sensor housing plug
4	Sensor housing base
5	Analog sensor board

6	Sensor element
7	Sensor housing cap (with flame arrester for Class 1 Div. 1 assemblies; without flame arrester for Class 1 Div. 2 assemblies)
8	Rain guard
9	Enclosure ground screw
10	Dust plug

Remote-Mounted Kit

A remote-mounted sensor kit can be ordered if the sensor needs to be somewhere that is not conveniently accessible for viewing the display screen.

The kit includes a second junction box on a cable with a cable bushing/cable gland. The cable can be ordered in 1-foot increments with a maximum of 250 feet.

The cable and cable bushing/cable gland are not explosion-proof. If the assembly is installed in a classified location, the cable bushing must be removed and replaced with explosion-proof conduit. You must meet local electrical codes and use appropriate construction technique to maintain the explosion-proof classification of the assembly.

Installation

This section describes procedures to mount the T2A in the monitoring environment and wire the T2A.

Mounting the T2A

1. Consider the following when you select the mounting site.
 - Select a site where the T2A is not likely to be bumped or disturbed. Make sure there is sufficient room to perform start-up, maintenance, and calibration procedures.
 - Select a site that is representative of the monitoring environment and where the target gas is likely to accumulate or where it is most likely to leak. The T2A should not be installed near an entrance, air intake, or exhaust point.
 - The sensor must point down.
 - Avoid installing the T2A in a location where airborne particles could cover or coat the sensor.

NOTE: These guidelines are **ONLY** intended as a general directive for the placement of the T2A. This information should **NOT** serve as a complete list when considering all potential parameters for the proper location of the unit. It is **STRONGLY** advised that a third party Certified Industrial Hygienist, or other Certified Safety Professional, conduct a site survey and annotate the location and quantity of detection devices that should be installed for **EVERY** installation of **EVERY** site.

2. Select a mounting location and installation hardware. Mounting to a concrete or steel structure is recommended to minimize vibration and moisture. Use a maximum 1/4"-20 bolt or 1/4" diameter screw, flat washers, Grade 5 material, and corrosion protection like paint, galvanization, or zinc plating.

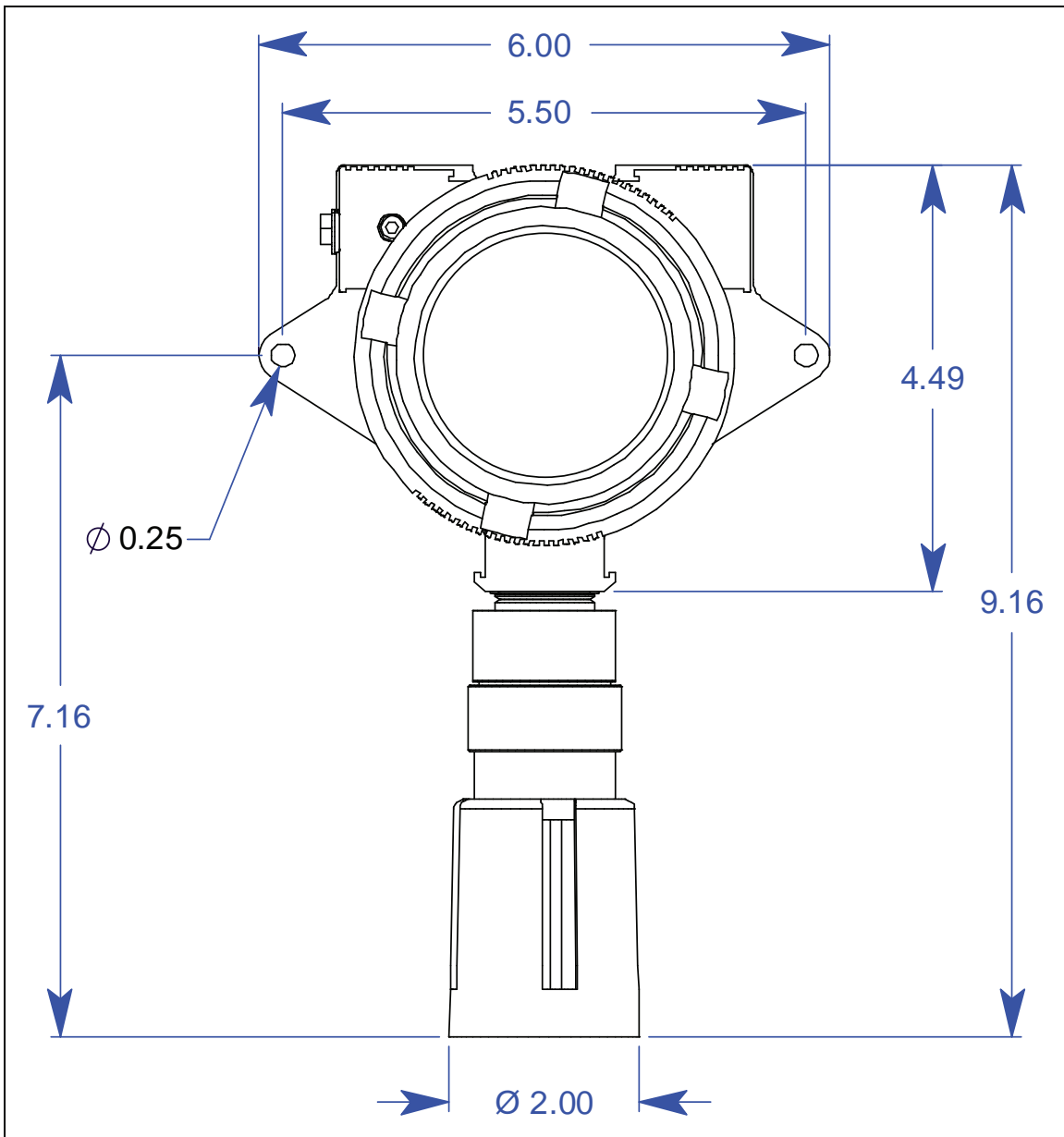

Figure 4: T2A Dimensions

3. For a remote-mounted kit, install the detector junction box at the monitoring environment using techniques appropriate for the mounting area's classification and for the local electrical code. The cable and cable bushing/cable gland sent with the assembly are not explosion-proof.

WARNING: *If installed in a classified area, use appropriate construction technique to maintain the explosion proof classification of the assembly.*

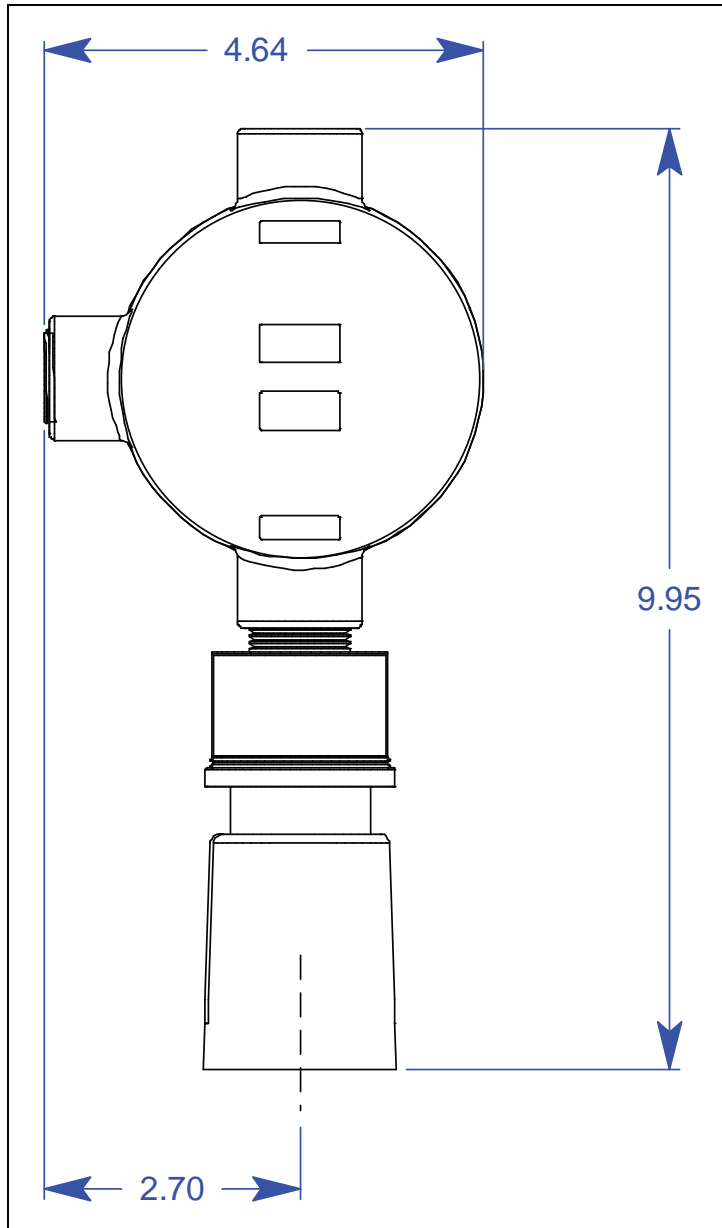

Figure 5: Remote-Mounted Kit's Detector Junction Box Dimensions

Remote-Mounted Kit Wiring

The remote-mounted kit generally comes prewired but if it becomes disconnected, follow these steps to reconnect it.

CAUTION: *The internal components can be static sensitive. Use caution when opening the enclosure and handling internal components.*

CAUTION: *Make sure the power source is off before beginning the wiring procedure.*

CAUTION: ***DO NOT** use any metal objects or tools to remove the terminal board from the internal system.*

1. Unscrew each enclosure lid and set it aside.
2. At the amplifier junction box, grab the thumbscrews and gently lift the internal system out of the enclosure. It can rest on the edge of the enclosure.
3. One end of the cable has a connector and the other has ferruled wires.
4. Feed the connector end of the cable through a conduit hub at the amplifier junction box.

WARNING: *If installed in a classified area, use appropriate construction technique to maintain the explosion proof classification of the assembly.*

5. Plug the connector into the sensor connector socket at the amplifier junction box.
6. Feed the ferruled-wire end of the cable through a conduit hub at the detector junction box.

WARNING: *If installed in a classified area, use appropriate construction technique to maintain the explosion proof classification of the assembly.*

7. Connect the ferruled wires to the color-coded terminals in the detector junction box.
8. Secure the detector junction box's enclosure lid back onto the enclosure.

Wiring Power and 4-20 mA Output

The T2A requires +12 to +35 Volts of wired DC power to operate. It sends a 4-20 mA signal out through the power wires.

CAUTION: *The internal components can be static sensitive. Use caution when opening the enclosure and handling internal components.*

CAUTION: *Make sure the power source is off before beginning the wiring procedure.*

CAUTION: ***DO NOT** use any metal objects or tools to remove the terminal board from the internal system.*

1. Unscrew the enclosure lid and set it aside.
2. Grab the thumbscrews and gently lift the internal system out of the enclosure. It can rest on the edge of the enclosure.

NOTE: Disconnecting the sensor connector plug from the sensor housing will allow for the complete removal of the internal system from the device enclosure. Disconnecting the internal system may provide ease in accessing the control board terminals for wiring. Reconnect the sensor connector plug before reinstalling the internal system.

3. Feed the power and 4-20 mA signal wires through the T2A's power hub and into the enclosure. The minimum recommended wire gauge is 26 AWG and the maximum recommended wire gauge is 14 AWG.

WARNING: *Use appropriate construction technique to maintain the explosion proof classification of the T2A.*

4. Connect the power and 4-20 mA signal wires to the Input Terminal Block as shown below.

CAUTION: *If shielded cable is used, leave the cable shield's drain wire disconnected and insulated at the T2A. You will connect the opposite end of the cable's drain wire to the controller's chassis (earth) ground.*

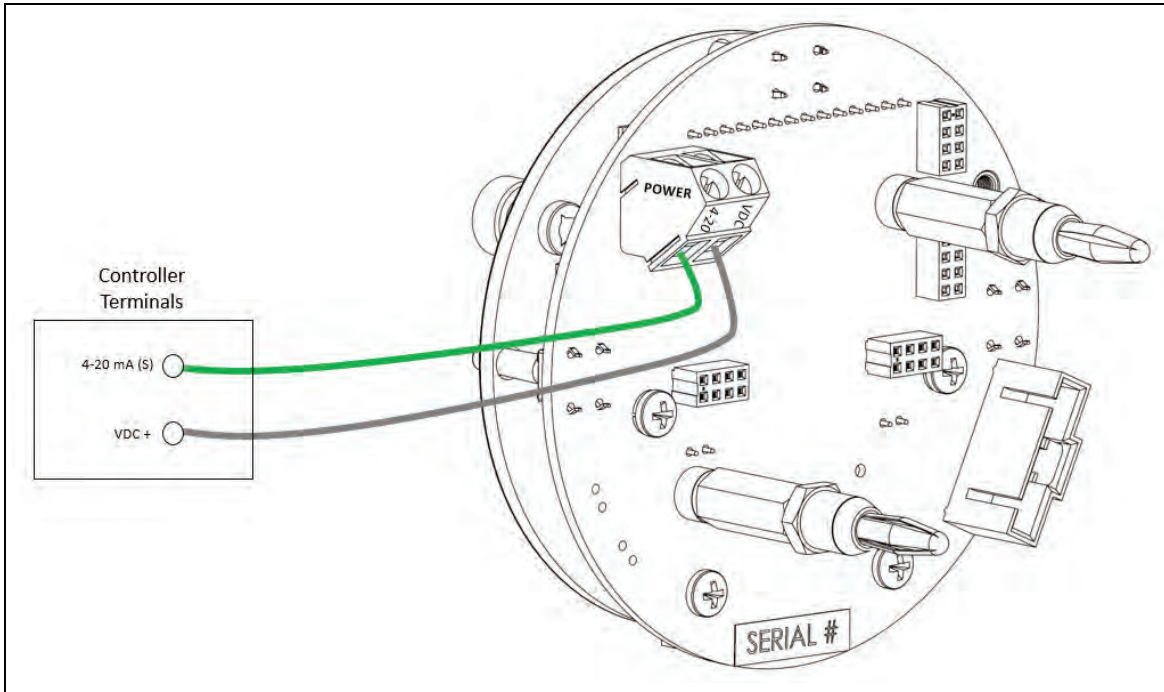

Figure 6: Wiring Power and Signal Wiring

5. If shielded cable is used, connect the cable's drain wire to an available chassis (earth) ground at the controller. RKI controllers typically have a ground stud that can be used to ground the cable's drain wire.

Closing the Enclosure

1. Place the internal system back into the enclosure, matching each mounting post to its corresponding eyelet anchored within the base of the enclosure.
2. Using the thumbscrews, gently push to seat the internal system into the mounting posts.

NOTE: The thumbscrews on the T2A function **ONLY** as thumb-holds for ease in removal of the internal system from the base of the enclosure. Do **NOT** attempt to loosen or tighten the thumbscrews when opening or closing the enclosure.

3. Verify that the sealing ring, seated at the threaded opening of the device enclosure, is correctly in place.
4. Secure the enclosure lid back onto the enclosure.

WARNING: *When securing the lid onto the device, tighten the enclosure lid by hand ONLY. Overtightening of the lid by use of hand-tools could result in damage to the O-ring, potentially compromising the moisture seal, resulting in an unsafe environment.*

Start Up

This section describes procedures to start up the T2A and place the T2A into normal operation.

1. Complete the installation procedures described earlier in this manual.
2. Verify that the power wiring is correct and secure.
3. Turn on the power source.
4. Verify that the controller is on and operating properly. Refer to the controller operator's manual.
5. The T2A automatically powers on and enters a 1 minute startup period.



6. At the end of the startup, the T2A is in Normal Operating Mode.

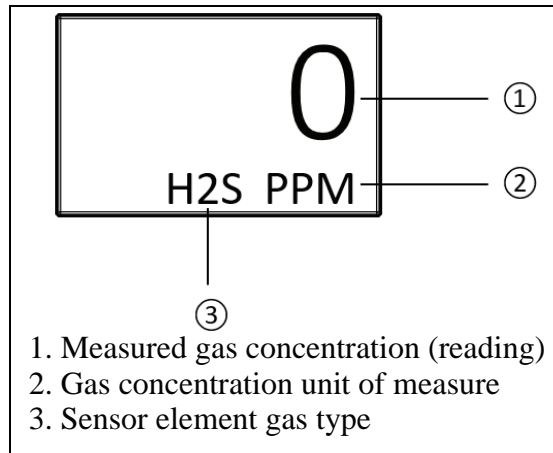

7. Allow the detector to warmup for the appropriate amount of time as shown below, depending on the sensor type.

Detection Gas	Warmup Time After an <u>Extended</u> Time Off Power	Warmup Time After a <u>Short</u> Time Off Power
Ammonia	12 hours	4 hours
Carbon Monoxide	2 hours	10 minutes
Chlorine		
Chlorine Dioxide		
Hydrogen Chloride		
Hydrogen Cyanide	12 hours	
Hydrogen Fluoride		
Hydrogen Sulfide	2 hours	
Nitric Oxide	12 hours	12 hours
Nitrogen Dioxide	2 hours	10 minutes
Oxygen		
Ozone		
Phosphine		
Sulfur Dioxide		

8. The T2A is factory-calibrated before shipping from RKI. If a full calibration is desired at startup, see page 35.

Operation

WARNING: Do not remove the sensor housing cap or enclosure lid while the circuits are energized unless the area is determined to be non-hazardous. Keep the sensor housing cap and enclosure lid tightly closed during operation.

Normal Operating Mode

While in Normal Operating Mode, the T2A continuously samples the air and updates the measured concentration of the target gas on the display screen. The display, when in Normal Operating Mode, appears as shown below.

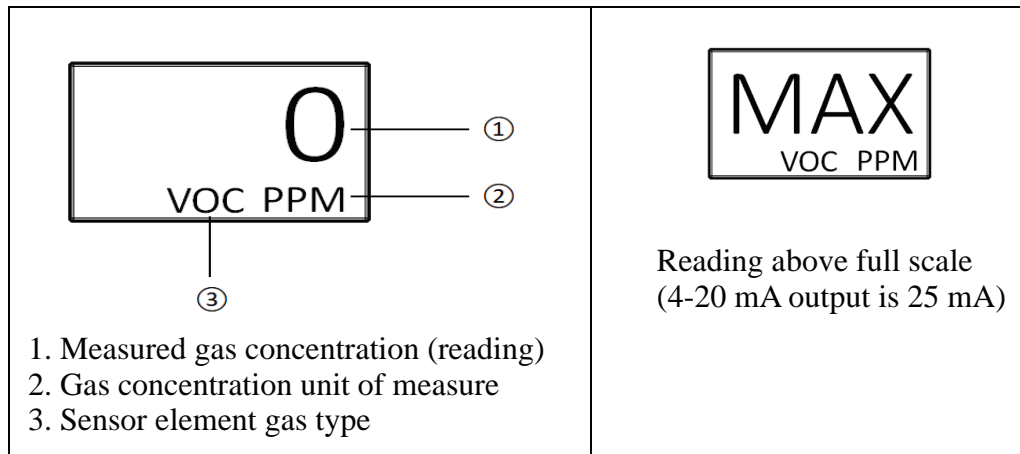

Magnetic Buttons

Use the provided magnet to actuate the T2A's buttons without having to remove the junction box's lid. Touch the magnet to the outer edge of the junction box lid near the button you want to actuate. Tapping the junction box is the same as pressing and releasing the button. Holding the magnet against the junction box is the same as pressing and holding the button.

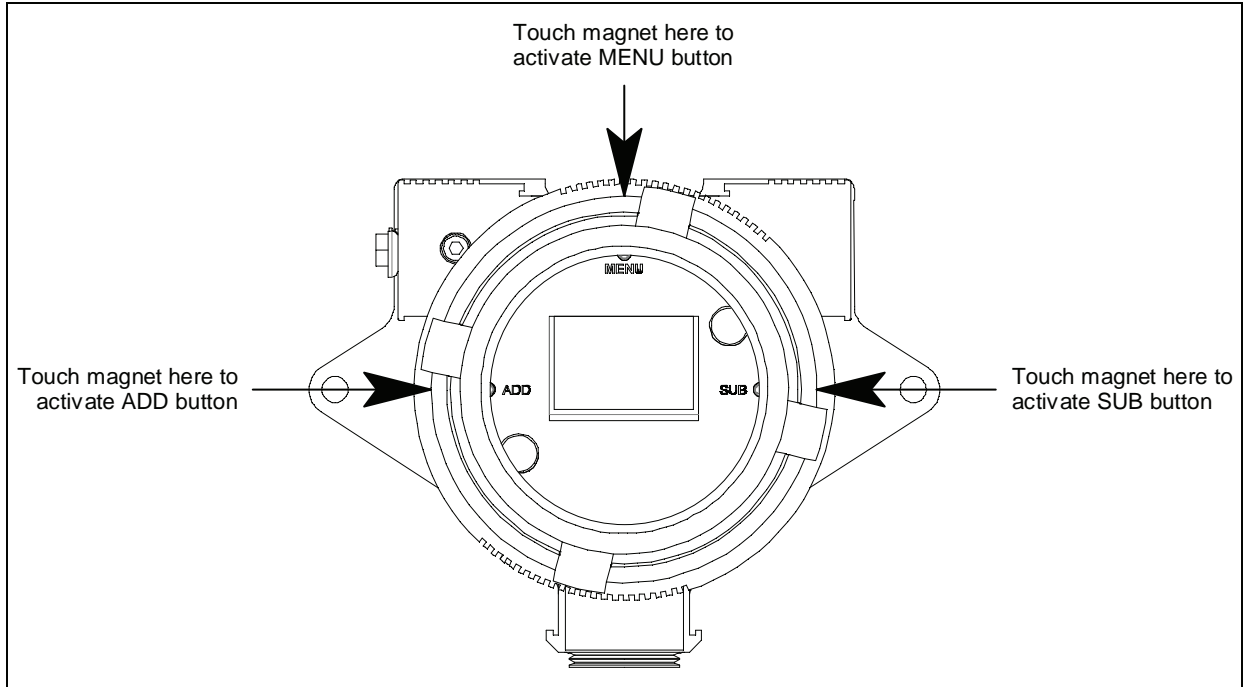

Powering the Device

When power is first applied to the T2A, the unit automatically powers on and begins the startup sequence. The directions below describe how to power off and power on the T2A once power has been applied.

Powering Off

Powering off the device stops the operation of the unit. The Product Settings and Configuration, as well as the operation settings, including the zero and calibration of the sensor, will be unaffected.

1. Press and hold the SUB button for approximately 6 seconds, until "OFF" shows on the display screen.

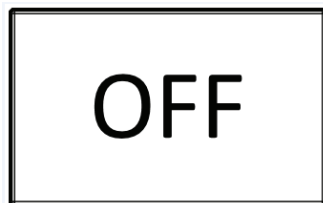

2. The display screen will continue to show "OFF" for the duration of time that the unit is powered off, as long as uninterrupted power is supplied to the unit.

Powering On

Powering on the device begins the operation of the unit, automatically initiating the system start-up cycle and 1-minute warmup period. The T2A will be in normal operating mode at the completion of the system start-up.

1. Press the ADD button once to turn the unit on.

Faults

In the event of a device failure, the unit will alternate between the normal operating screen and a fault screen on the display, in 5 second intervals, until the fault has been cleared, or is corrected. The fault code, located in the bottom-left corner of the display, appears on both screens. The unit continuously registers that the system is in fault. When the fault is corrected, the unit will return to normal operating mode.

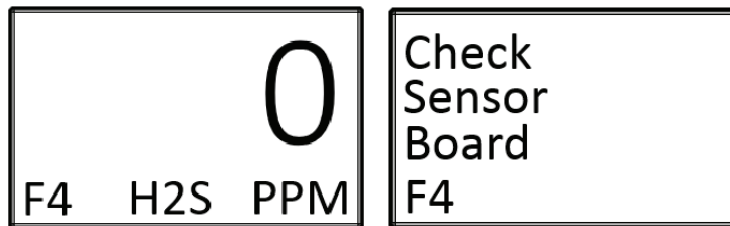

For a list of the fault codes and warning symbols of the T2A, and their associated meaning, see page 32.

Accessing Menus

The Product Settings and Configuration menu is accessible from Normal Operating Mode. To access the Product Settings and Configuration menu, **press and hold** the **MENU** button, for approximately 6 seconds, until the menu is activated and open on the display screen.

NOTE: After 5 minutes of no interaction with the device, the unit will automatically return to normal operating mode.

Product Settings and Configuration

The Product Settings and Configuration menu allows the end-user to tailor the device settings to meet their required specifications and/or site conditions.

The T2A continues monitoring for gas while in the Product Settings and Configuration menu.

The Product Settings and Configuration menu consist of the following screens:

- Alarm Test (see page 24)
- System Information (see page 25)
- Zero/Calibration Timers (see page 26)
- Calibration Method (see page 26)
- 4-20 mA Offset Settings: Zero Offset Setting, Full-Scale Offset Setting (see page 27)
- Display Screen Contrast Setting (see page 28)
- Return to Factory Default Settings (see page 29)
- Reset Zero and Calibration Values Only (see page 30)

Entering the Product Settings and Configuration Menu

While the device is in normal operating mode, **press and hold** the **MENU** button, for approximately 6 seconds, until the Product Settings and Configuration menu is activated and open on the display screen.

NOTE: After 5 minutes of no interaction with the device, the unit will automatically return to normal operating mode.

Alarm Test

The alarm test simulates a gas level reading. The alarm test is used to ensure the proper functionality of the relay settings on the controller. The test can also be used to simulate emergency/safety drills onsite.

NOTE: Triggering T2A relays will also simulate alarm conditions at the controller. Controllers cannot distinguish between real and simulated data received. When the controller relays are triggered, alarm devices will perform as intended, initiating emergency procedures as if a harmful or toxic gas was actually present. To prevent this from occurring, set the controller to calibration mode before performing the alarm test. Calibration mode allows data transmission without relay activation.

It is recommended that an alarm test be conducted EVERY 30 days, alongside the maintenance and calibration of the detector.

Performing the Alarm Test

The alarm test gas level reading can be increased or decreased in increments of 5% of the sensor scale, up to 100% of the sensor scale.

1. Enter the Product Settings and Configuration menu by pressing and holding the MENU button for 6 seconds. The alarm test screen appears.



2. Press the ADD button until the low and high alarm levels are reached and the relay(s) are triggered to light all visual alarm(s) and sound all audio alarm(s) on the controller.
3. Once all relays have been tested and the test is complete, press the SUB button to return the alarm test reading back to zero and to deactivate the controller alarm(s).
4. Use the MENU button to scroll through the rest of the Product Settings and Configuration menu and return to Normal Operating Mode.

System Information

The system information screen allows the end-user to view the following information:

- The scale of the sensor element.
- The voltage value (in volts) that the sensor was reading when zeroed.
- The current voltage value (in volts) that the sensor element is reading.
- The sensor assembly's serial number.
- The sensor assembly's date of manufacture.

This screen is for informational purposes only.

1. If necessary, enter the Product Settings and Configuration menu by pressing and holding the MENU button for 6 seconds.
2. Press and release the MENU button until the System Information screen appears.

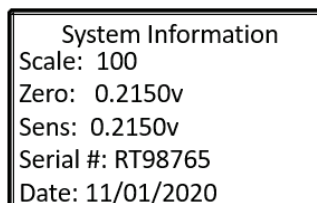

3. Review the information displayed.
4. Use the MENU button to scroll through the rest of the Product Settings and Configuration menu and return to Normal Operating Mode.

Zero/Calibration Timer Information

The zero/calibration time information screen allows the end-user to view the following information:

- The days since the sensor assembly was last zeroed.
- The days since the sensor assembly was last calibrated.
- The calibration number of the sensor, used for diagnostic purposes.

This screen is for informational purposes only.

NOTE: The Cal field automatically updates after an Auto Cal. When performing a Manual Cal, the gas reading must be adjusted by at least one button press to get the Cal field to update.

1. If necessary, enter the Product Settings and Configuration menu by pressing and holding the MENU button for 6 seconds.
2. Press and release the MENU button until the Zero/Calibration Timer Information screen appears.

LAST SETUP TIMES: Zero: 1 Day(s) Cal: 1 Day(s) Cal #: 0.00

3. Review the information displayed.
4. Use the MENU button to scroll through the rest of the Product Settings and Configuration menu and return to Normal Operating Mode.

Calibration Method

NOTE: HCl - It is recommended that HCl versions only be calibrated using Auto Cal but they can be calibrated using Manual Cal, if desired.

O₂ - If calibrating with 100% N₂, you must use Manual Cal. To calibrate using Auto Cal, a gas concentration between 10 and 18% O₂ is recommended.

The calibration method selection allows you to choose how you calibrate the sensor element.

Manual Calibration (factory setting): Use the ADD and SUB buttons during calibration to match the reading shown on the screen to the value of the gas being applied.

Auto Calibration: Sets the reading, after a predetermined amount of time, during calibration to the value entered during the auto calibration setup process.

1. If necessary, enter the Product Settings and Configuration menu by pressing and holding the MENU button for 6 seconds.

2. Press and release the MENU button until the Cal Method screen appears.

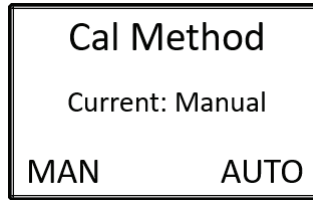

3. Use the ADD button to select manual calibration and the SUB button to select auto calibration.
4. Use the MENU button to scroll through the rest of the Product Settings and Configuration menu and return to Normal Operating Mode.

4-20 mA Offset Settings

Setting the 4-20 mA offset allows the end-user to calibrate the sensor's analog output. Upon installation of the device, if the detected gas reading on T2A does not correspond to the reading on the controller, the zero offset (4 mA) and the full-scale offset (20 mA) can be adjusted on the unit.

Over time, as electronic components suffer from normal wear and tear, the circuits will tend to drift. This drift can cause variances in the amount of current output by the sensor, or in the current measurement by the controller. If at any time the reading on the T2A no longer matches the reading on the controller, the 4-20 mA offset will need to be recalibrated.

The factory default settings on the T2A for the 4-20 mA offset are 4.00 mA for the zero offset and 20.00 mA for the full-scale offset.

1. If necessary, enter the Product Settings and Configuration menu by pressing and holding the MENU button for 6 seconds.
2. Press and release the MENU button until the 4-20 mA Offset screen appears.

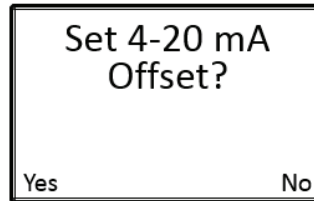

3. Press and release the ADD button to set the 4-20 mA offset and advance to the zero offset setting screen. If you do not wish to set the 4-20 mA offset, press and release the SUB or MENU button to advance to the display screen contrast setting screen.

Zero Offset Setting

If “Yes” is selected to set the 4-20 mA offset:

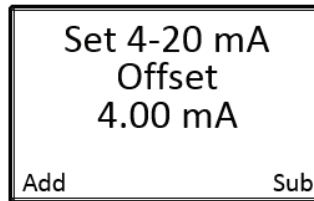

1. Use the ADD and SUB buttons to increase and decrease the zero offset on the unit, respectively, until the controller reads 0 %/ppm, depending on the gas type being detected.
2. Press the MENU button to save the desired setting and to advance to the full-scale offset setting screen.

Full-Scale Offset Setting

NOTE: Adjusting the full-scale offset will initiate alarm conditions. Disable the alarms or make sure all personnel are aware that any alarms are false.

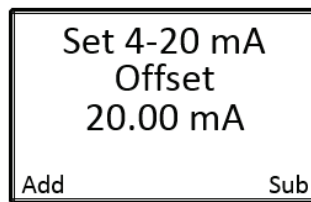

1. Use the ADD and SUB buttons to increase and decrease the full-scale offset, respectively, until the controller reads the full scale value for that channel.
2. Press the MENU button to save the desired setting and to advance to the display screen contrast setting screen.

Display Screen Contrast Setting

The display screen contrast is the difference in luminance or color that makes the displayed images distinguishable. Due to varying external elements, such as extreme sunlight, the brightness of the display screen may need to be adjusted for optimum viewing.

The factory default setting on the T2A for the display screen contrast is 29, approximately 45% of the contrast scale. The contrast setting ranges from 1 to 64.

NOTE: Setting the contrast too low will cause the display image to become faint or indistinguishable, especially when the unit is located in areas with full-sun. The resulting field of view could be misinterpreted as an error within the device. Be sure to verify that the selected contract is within an appropriate range of viewing.

1. If necessary, enter the Product Settings and Configuration menu by pressing and holding the MENU button for 6 seconds.

2. Press and release the MENU button until the Contrast screen appears.



3. Use the ADD and SUB buttons to brighten and dim the contrast, respectively.
4. Use the MENU button to scroll through the rest of the Product Settings and Configuration menu and return to Normal Operating Mode.

Return to Factory Default Settings

Returning the T2A to its factory default settings will reset all customization of the device, including the zero and calibration settings of the sensor element. A factory default does not change the gas type.

T2A Product and Configuration Factory Default Settings	
Configuration	Setting
Alarm Test	--
System Information	--
Zero/Calibration Timer	*Cleared*
Calibration Method	Manual
4-20 mA Zero Offset Setting	4.00 mA
4-20 mA Full-Scale Offset Setting	20.00 mA
Contrast	--

T2A Operation Factory Default Settings	
Configuration	Setting
Sensor Element Zero	*Cleared*
Sensor Element Calibration	*Cleared*

1. If necessary, enter the Product Settings and Configuration menu by pressing and holding the MENU button for 6 seconds.
2. Press and release the MENU button until the Return to Factory Default screen appears.

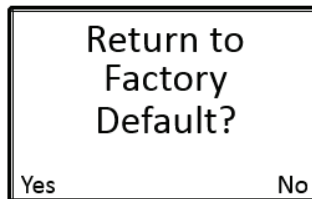

3. Press the ADD button to return the device to its factory default settings and to advance to the return to factory default settings confirmation screen. If you do not wish to return the device to its factory default settings, press the SUB or MENU button to continue to the Reset Zero & Cal Only screen.
4. If “Yes” is selected to return the device to its factory default settings:

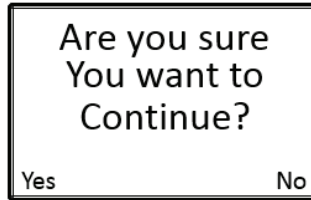

5. Press the ADD button to select “Yes” to confirm that you want to reset the device to its factory default settings and to return the device to normal operating mode. If you do not wish to continue to return the device to its factory default settings, press the SUB button to select “No” to continue to the Reset Zero & Cal Only screen.
6. Use the MENU button to scroll through the rest of the Product Settings and Configuration menu and return to Normal Operating Mode.

NOTE: If the T2A is reset to the factory default settings, ALL configuration steps MUST be repeated and the device MUST then be zeroed and calibrated for proper operation of the device.

Reset Zero & Calibration Values

Resetting the zero and calibration settings of the sensor element will allow the currently stored zero and calibration values to be rest without having to reconfigure all of the other operational settings like with the Return to Factory Defaults option.

1. If necessary, enter the Product Settings and Configuration menu by pressing and holding the MENU button for 6 seconds.
2. Press and release the MENU button until the Reset Zero & Calibration Values screen appears.

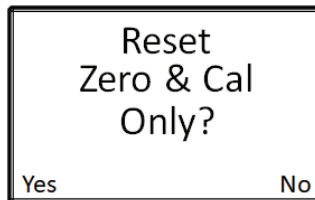

3. Press the ADD button to select “Yes” to reset the Zero and Calibration values and to advance to the Reset Zero & Cal Only confirmation screen. If you do not wish to reset the zero and calibration values, press the SUB button to select “No” to leave the Product Settings and Configuration menu and to return the device to normal operating mode.

4. If “Yes” is selected to reset the zero and calibration values:

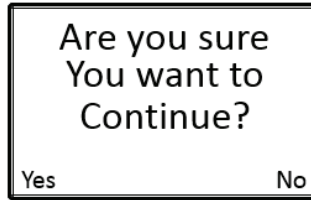

5. Press the ADD button to select “Yes” to confirm that you want to reset the Zero and Calibration values and to return the device to normal operating mode. If you do not wish to continue to reset the Zero and Calibration values, press the SUB button to select “No” to leave the Product Settings and Configuration menu and to return the device to normal operating mode.
6. Press and release the MENU button to return to Normal Operating Mode.

NOTE: If the T2A’s stored Zero and Calibration values are reset, the device **MUST** be zeroed and calibrated for proper and safe operation of the device.

Maintenance

RKI recommends that our equipment be calibrated a **MINIMUM** of every 90 days, and **STRONGLY** advise that calibration be performed every 30 days. Without knowing the specific application, sensor assembly location, gas exposure and other factors, the company recommends monthly calibrations – assuming no damage or potential damage has occurred to the sensor and that there has not been a power outage to the sensor assembly. If damage has occurred or the power supplied to the sensor has changed, a calibration should be completed immediately.

Scheduled maintenance should include the zero and calibration of the sensor (see page 35) and an alarm test (see page 24).

The sensor head should be kept free of airborne particles, dirt, mud, spider webs, bugs and insects, and/or any other debris that could potentially cover or coat the sensor. Keeping the sensor head clear of foreign articles will allow for proper operation of the device. A brief inspection during scheduled maintenance should suffice, but dependent upon the location and the environment in which the unit is installed, more frequent inspections may be warranted.

The T2A may be adversely affected by the exposure to certain airborne substances. Loss of sensitivity or corrosion may be gradual, if such materials are present in sufficient concentrations. The performance of the device may be impaired during operation in the presence of substances that can cause corrosion on gold plating. Continuous and high concentrations of corrosive gases may also have a detrimental long-term effect on the product’s service life. The presence of such substances in an area does not preclude the use of this device, but the likelihood of the shortened lifetime of the sensor element, as a result, should be noted. Use of the T2A in these environments may require more frequently scheduled maintenance to ensure safe and reliable system performance.

Troubleshooting

The troubleshooting guide describes symptoms, probable causes, and recommended action for problems you may encounter with the T2A.

NOTE: See the controller operator's manual for problems you may encounter with the controller.

T2A Fault Codes		
Problem	Cause(s)	Solution(s)
F4 Check Sensor Board	The control board has lost communication with the sensor interface board.	1. Replace the sensor interface board.
F5 Try to Zero Again	The unit did not zero correctly, due to: <ul style="list-style-type: none">• the presence of gas,• a sensor error, or• a sensor interface board error.	1. Re-zero the device in clear air. 2. Replace the sensor element. 3. Replace the sensor interface board.
F6 Try to Calibrate Again	The unit did not calibrate correctly, due to: <ul style="list-style-type: none">• the absence of gas,• a sensor error, or• a sensor interface board error.	1. Recalibrate the sensor element and verify that gas is present during calibration. 2. Replace the sensor element. 3. Replace the sensor interface board.

If the T2A does not turn on, confirm the presence of 12-35 VDC at the Input Terminal Block using a DMM set to read in DC volts.

Desiccant Replacement

Each T2A comes with a desiccant bag installed in the junction box. The contents are blue when it is dry. As the desiccant absorbs moisture, it turns amber. Periodically check the desiccant and replace it if it has turned amber.

Sensor Replacement

RKI recommends replacing the sensor element whenever a slow response to gas is observed during the normal calibration process. After replacing the sensor element, the device **MUST** be zeroed and calibrated for proper operation of the device.

WARNING: *Do not remove the sensor housing cap or enclosure lid while the circuits are energized unless the area is determined to be non-hazardous. Keep the sensor housing cap and enclosure lid tightly closed during operation.*

CAUTION: *The internal components can be static sensitive. Use caution when opening the enclosure and handling internal components. DO NOT use any metal objects or tools to remove the sensing element from the sensor adapter board.*

1. Turn off power to the T2A.
2. Unscrew the rain guard.
3. Unscrew and remove the sensor housing cap from the sensor housing base. Set aside.

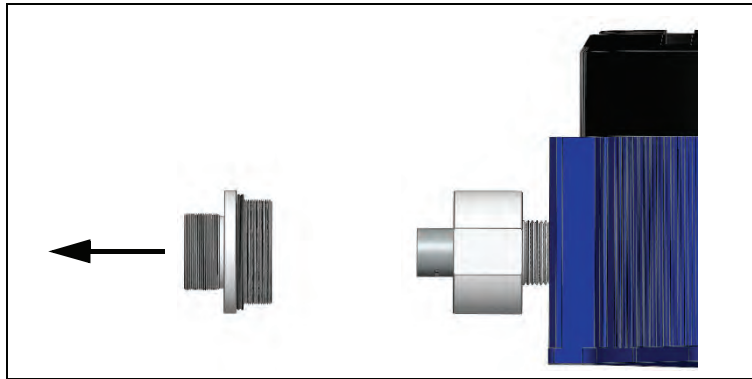

4. Gently unplug the sensor element from the sensor housing board.

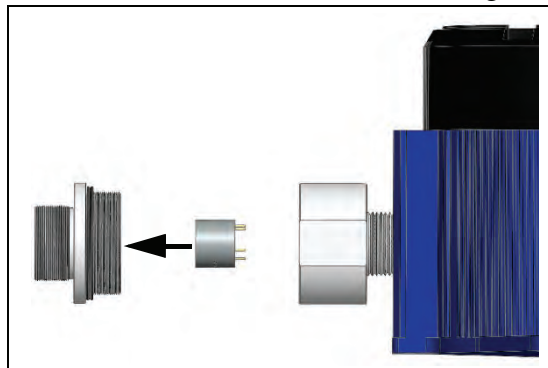

5. Plug the new sensor element into the sensor housing board. Ensure that the pins on the sensing element align with the sockets on the sensor housing board.

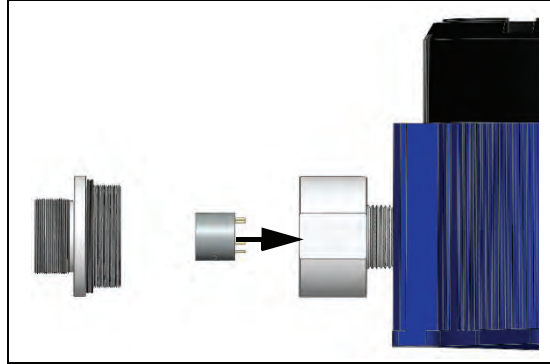

6. Screw the sensor housing cap back onto the sensor housing base, ensuring that the sensor housing cap is only tightened hand tight.

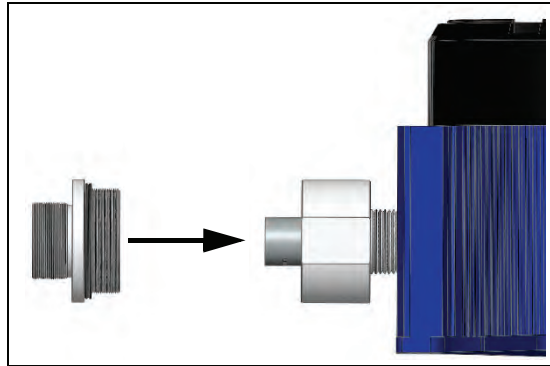

7. Press the ADD button to turn the T2A on.
8. Allow the detector to warmup for the appropriate amount of time as shown below, depending on the sensor type.

Detection Gas	Warmup Time
Ammonia	12 hours
Carbon Monoxide	2 hours
Chlorine	
Chlorine Dioxide	
Hydrogen Chloride	12 hours
Hydrogen Cyanide	
Hydrogen Fluoride	2 hours
Hydrogen Sulfide	
Nitric Oxide	12 hours

Detection Gas	Warmup Time
Nitrogen Dioxide	2 hours
Oxygen	
Ozone	
Phosphine	
Sulfur Dioxide	

9. Zero and calibrate the detector as described on page 35.

Calibration

Calibration is the process of evaluating and adjusting the precision and accuracy of measurement equipment. Although RKI calibrates every device at the factory, for best accuracy, the detector SHOULD be calibrated in the environment where it is installed.

Calibration Frequency

A calibration should be performed EVERY thirty (30) days. Days since the last calibration should NEVER exceed ninety (90) days. RKI recommends that you calibrate your device regularly to ensure proper functionality and a safe work environment.

Materials

- 0.5 LPM fixed flow regulator with knob

WARNING: *If calibrating with Cl₂ or HCl, a regulator must be dedicated for use with that gas only. Do not use that dedicated regulator for any other gases, particularly H₂S.*

- calibration cup
- calibration tubing
- zero air cylinder (if not in a fresh air environment)
- calibration cylinder or gas generator (For O₂ sensors calibrated with Manual Cal, RKI recommends using 100% N₂. For O₂ sensors calibrated with Auto Cal, RKI recommends a concentration between 10 and 18% O₂. For all other sensors, RKI recommends using 50% of the full scale value of your detected gas.)

NOTE: Some detected gases use surrogate gases for calibration. Detected gases needing a surrogate gas for calibration are listed below. If you are using a surrogate gas for calibration, that surrogate gas concentration multiplied by the factor listed below should equal about 50% of the detected gas' full scale.

Table 2: Surrogate Calibration Gases

Detected Gas	Surrogate Calibration Gas	Factor
ClO ₂	Cl ₂	1
HF	Cl ₂	5

Zeroing the Sensor (20.9% for O₂)

The first step of calibration is zeroing (20.9% for O₂). The zeroing (20.9% for O₂) process **MUST** be performed in known clean air, with no contaminants or hazardous gasses present. If air quality cannot be guaranteed, a cylinder of zero air will be required to properly zero the sensor.

1. While the product is in normal operating mode, press the MENU button to activate the Operation Settings menu.

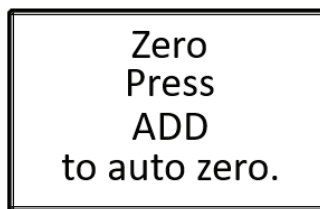

2. Press the ADD button to begin the zero process and advance to the clean air confirmation screen.

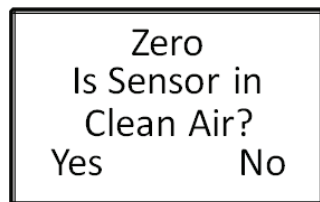

3. If the sensor is in clean air, press the ADD button to select "Yes" and continue to Step 5.
4. If the sensor is not in clear air:
 - a. Unscrew and remove the rain guard from the assembly.
 - b. Install the calibration cup to the T2A's sensor housing.
 - c. Screw the regulator into the zero air calibration cylinder.
 - d. Use the sample tubing to connect the regulator to the calibration cup.
 - e. Turn the regulator knob counterclockwise to open the regulator.

- f. Allow the gas to flow for 1 minute.
 - g. Press the ADD button to select “Yes” and continue to Step 5.
5. The unit will automatically begin the 6-second zero process. During the zero, the display will show a countdown of the time remaining until the process is complete.

NOTE: The zero process cannot be stopped without disconnecting the power from the unit.

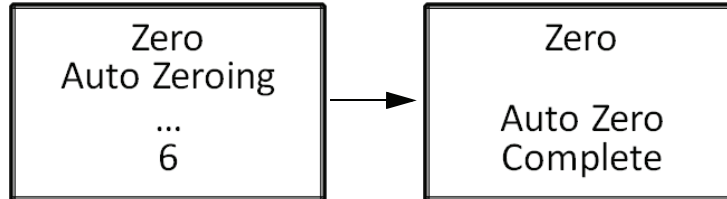

6. When the zero process is complete, press the MENU button to advance to the calibration screen.
7. If a zero air calibration cylinder was used, turn the regulator knob clockwise to close the regulator.

Calibrating the Sensor (Manual Cal)

Either the Manual Cal screen or the Auto Cal screen appear, depending on how Calibration Method is set in the Product Settings and Configuration Menu (see page 26).

NOTE: HCl - It is recommended that HCl versions only be calibrated using Auto Cal but they can be calibrated using Manual Cal, if desired.

O₂ - If calibrating with 100% N₂, you must use Manual Cal. To calibrate using Auto Cal, a gas concentration between 10 and 18% O₂ is recommended.

You should **ONLY** calibrate the sensor after completing the zero process.

1. If you are calibrating with HCl calibration gas, connect the tubing to the regulator, turn the regulator on, and allow gas to flow for 10 minutes before proceeding.
2. If you followed the instructions in Zeroing the Sensor (20.9% for O₂), the screen below is displayed.

If you are accessing Manual Cal from Normal Operating Mode, press MENU twice.

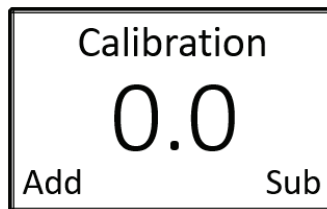

3. Unscrew and remove the rain guard from the assembly.
4. Install the calibration cup to the T2A's sensor housing.

5. Screw the regulator into the calibration cylinder.
6. Use the sample tubing to connect the regulator to the calibration cup.
7. Turn the regulator knob counterclockwise to open the regulator.
8. After 20-30 seconds, start using the ADD and SUB buttons to adjust the reading to match the concentration listed on the calibration cylinder.
9. For all calibration gases except Cl₂, ClO₂, and HCl: Let the gas flow for 1 minute.
For Cl₂ and ClO₂ calibration gas: Let the gas flow for 6 minutes.
For HCl calibration gas: Let the gas flow for 5 minutes.
10. Use the ADD and SUB buttons to finish adjusting the reading on the screen to match the concentration listed on the calibration cylinder.
For detectors using a surrogate gas, adjust the reading to match the surrogate gas concentration multiplied by the factor listed in Table 2 on page 36.

NOTE: Even if the reading does not need adjustment to match the calibration cylinder's concentration, you must adjust it up and then back down to reset the Cal field in the Zero/Calibration Timer Information screen.

11. When calibration is complete, remove the calibration cup from the sensor housing and reinstall the rain guard.
12. Use the MENU button to return to Normal Operating Mode.



Calibrating the Sensor (Auto Cal)

Either the Manual Cal screen or the Auto Cal screen appear, depending on how Calibration Method is set in the Product Settings and Configuration Menu (see page 26).

You should ONLY calibrate the sensor after completing the zero process.

NOTE: O_2 - If calibrating with 100% N_2 , you must use Manual Cal. To calibrate using Auto Cal, a gas concentration between 10 and 18% O_2 is recommended.

1. If you are calibrating with HCl calibration gas, connect the tubing to the regulator, turn the regulator on, and allow gas to flow for 10 minutes before proceeding.
2. If you followed the instructions in Zeroing the Sensor (20.9% for O_2), the screen below is displayed.

If you are accessing Auto Cal from Normal Operating Mode, press MENU twice.

Calibration		
Would you like to cal this unit?		
Yes	No	

3. Press the ADD button to select “Yes” to begin the calibration process and to advance to the calibration confirmation screen. If you do not wish to calibrate the sensor, press the SUB button to select “No” to advance to the sensor radio address setting screen.

Calibration		
Are you sure You want to cal?		
Yes	No	

4. Press the ADD button to select “Yes” to confirm that you want to calibrate the sensor and to continue to the concentration setting screen. If you do not wish to continue to calibrate the sensor, press the SUB button to select “No” to advance to the sensor radio address setting screen.

Calibration		
Set PPM. Hit Menu when done		
Add	50	Sub

5. Use the ADD and SUB buttons to adjust the concentration match the concentration shown on the calibration cylinder.

For detectors using a surrogate gas, adjust the reading to match the surrogate gas concentration multiplied by the factor listed in Table 2 on page 36.

6. Press the MENU button to save the gas concentration setting and to advance to the calibration start screen.
7. Unscrew and remove the rain guard from the assembly.
8. Install the calibration cup to the T2A's sensor housing.
9. Screw the regulator into the calibration cylinder.
10. Use the sample tubing to connect the regulator to the calibration cup.
11. Turn the regulator knob counterclockwise to open the regulator.

Calibration
Apply gas then
hit menu button

12. Press the MENU button to begin calibrating the sensor. The unit automatically begins the calibration process. During calibration, the display shows a countdown of the time remaining until the process is complete. The amount of time varies based on the gas type.

Calibration
It will be caled
At the end of timer
120

NOTE: Once the calibration countdown has started, the process cannot be stopped without disconnecting the power from the unit.

13. When calibration is complete, remove the calibration cup from the sensor housing and reinstall the rain guard.

Calibration
Unit is now caled
to 50 PPM.
Reading: 50

NOTE: If the sensor responds extremely slow, or does not respond to the applied gas, it may indicate a failed sensor element. The sensor element will need to be replaced before completing the zero and calibration process.

14. Turn the regulator knob clockwise to close the regulator.

15. Use the MENU button to Normal Operating Mode.



Parts List

Table 3 lists replacement parts and accessories for the T2A.

Table 3: Parts List

Part Number	Description
47-5110-XX	Cable with connector for remote-mounted kit (specify length in 1-foot increments, up to 250 feet, when ordering)
61-2001	Detection junction box for remote-mounted kit, explosion-proof
66-0001	Sensor, carbon monoxide (CO), for up to 1,000 ppm full scale
66-0002	Sensor, oxygen (O ₂), 25% volume full scale
66-0003-1	Sensor, hydrogen sulfide (H ₂ S), 100 ppm full scale
66-0004	Sensor, hydrogen chloride (HCl), for up to 30 ppm full scale
66-0005	Sensor, hydrogen cyanide (HCN), 30 ppm full scale
66-0006-1	Sensor, ammonia (NH ₃), for up to 100 ppm full scale
66-0006-2	Sensor, ammonia (NH ₃), for 200 to 1,000 ppm full scale
66-0007	Sensor, nitric oxide (NO), for up to 250 ppm full scale
66-0008	Sensor, nitrogen dioxide (NO ₂), 20 ppm full scale
66-0009-2	Sensor, ozone (O ₃)
66-0010	Sensor, sulfur dioxide (SO ₂), 20 ppm full scale
66-0012	Sensor, chlorine (Cl ₂), for up to 20 ppm full scale
66-0013	Sensor, chlorine dioxide (ClO ₂), for up to 5 ppm full scale
66-0014	Sensor, hydrogen fluoride (HF), 10 ppm full scale
66-0015	Sensor, phosphine (PH ₃), 5 ppm full scale
71-0529	T2A Operator's Manual (this document)
81-0064RK-01	Calibration cylinder, 50 ppm CO in air, 34 liter steel
81-0064RK-03	Calibration cylinder, 50 ppm CO in air, 103 liter
81-0076RK	Zero air calibration cylinder, 17 liter
81-0076RK-01	Zero air calibration cylinder, 34 liter steel
81-0076RK-03	Zero air calibration cylinder, 103 liter
81-0078RK-01	Calibration cylinder, 100% nitrogen, 34 liter steel
81-0078RK-03	Calibration cylinder, 100% nitrogen, 103 liter

Table 3: Parts List

Part Number	Description
81-0151RK-02	Calibration cylinder, 25 ppm H ₂ S in nitrogen, 58 liter
81-0151RK-04	Calibration cylinder, 25 ppm H ₂ S in nitrogen, 34 liter aluminum
81-0170RK-02	Calibration cylinder, 5 ppm SO ₂ in nitrogen, 58 liter
81-0170RK-04	Calibration cylinder, 5 ppm SO ₂ in nitrogen, 34 liter aluminum
81-0176RK-02	Calibration cylinder, 25 ppm NH ₃ in nitrogen, 58 liter
81-0176RK-04	Calibration cylinder, 25 ppm NH ₃ in nitrogen, 34 liter aluminum
81-0190RK-02	Calibration cylinder, 5 ppm Cl ₂ in nitrogen, 58 liter
81-0190RK-04	Calibration cylinder, 5 ppm Cl ₂ in nitrogen, 34 liter aluminum
81-0192RK-02	Calibration cylinder, 2 ppm Cl ₂ in nitrogen, 58 liter
81-0192RK-04	Calibration cylinder, 2 ppm Cl ₂ in nitrogen, 34 liter aluminum
81-1050RK	Regulator with gauge and knob, 0.5 LPM, for 17 liter and 34 liter steel calibration cylinders (cylinders with external threads)
81-1051RK	Regulator with gauge and knob, 0.5 LPM, for 34 liter aluminum, 58 liter, and 103 liter calibration cylinders (cylinders with internal threads)
81-1183	Calibration cup with 3 foot tube
81-1184	Rain guard
82-0101RK	Magnetic wand

Appendix A: 4-20 mA Signal

This appendix is only an introduction. The information should serve as a brief overview of 4-20 mA current loop signal ranges and should not be considered a complete reference for proper implementation or use.

Industry standards pertaining to 4-20 mA current loop signals and other aspects of electronics are assumed to be known by the technician. For proper connection to a controller or Programmable Logic Controller (PLC), refer to the manufacturer's specific manual or instructions for that device.

Overview

When using 4-20 mA wired output signal devices, the 4-20 mA defines the current loop analog signal range, with 4 mA representing the lowest end of the range and 20 mA the highest. The relationship between the current loop and the gas value is linear. In addition, the T2A uses values below 4 mA to indicate special status conditions, as shown below:

4-20 mA Ranges	
Current	Detector Status
2 mA	Sensor Fault
3 mA	Sensor in Menu Mode
3.5 mA	Sensor being Calibrated

The 4 mA allows the receiving controller/PLC to distinguish between a zero signal, a broken wire, or an unresponsive instrument. Benefits of 4-20 mA convention are that it is: an industry standard, low-cost to implement, can reject some forms of electrical noise, and the signal does not change value around the "loop" (as opposed to voltage). The key advantage of the current loop is that the accuracy of the signal is not affected by a potential voltage drop in the interconnected wiring. Even with significant resistance in the line, the current loop T2A will maintain the proper current for the device, up to its maximum voltage capability.

Only one current level can be present at any time. Each device that operates via a 4-20 mA current loop signal must be wired directly to the controller. Units that are wired in a daisy chain configuration for the 4-20 mA current loop signal will not properly transmit data communications to the controller.

Calculations

$$I_{(4-20)} = \left(\frac{(16)(\text{value})}{\text{scale}} \right) + 4$$

$I_{(4-20)}$ = Current of loop, measured in mA

value = ppm (or %) of gas concentration

scale = full scale of sensor

Measuring Current

If the value measured is 0 mA, then: the loop wires are broken, the sensor assembly is not powered up, the sensor assembly is malfunctioning, or the controller is malfunctioning. A digital multi-meter (DMM), or current meter, may be used in conjunction with the controller and/or to test the 4-20 mA current loop signal. To measure the current, place the meter probes in line with the current loop.