

65-2405RK Combustible Gas Transmitter Operator's Manual

Part Number: 71-0132RK

Revision: B

Released: 2/16/11

WARNING

Read and understand this instruction manual before operating detector. Improper use of the detector could result in bodily harm or death.

Periodic calibration and maintenance of the detector is essential for proper operation and correct readings. Please calibrate and maintain this detector regularly! Frequency of calibration depends upon the type of use you have and the sensor types. Typical calibration frequencies for most applications are between 3 and 6 months, but can be required more often or less often based on your usage.

Product Warranty

RKI Instruments, Inc. warrants gas alarm equipment sold by us to be free from defects in materials, workmanship, and performance for a period of one year from date of shipment from RKI Instruments, Inc. Any parts found defective within that period will be repaired or replaced, at our option, free of charge. This warranty does not apply to those items which by their nature are subject to deterioration or consumption in normal service, and which must be cleaned, repaired, or replaced on a routine basis. Examples of such items are:

- a) Absorbent cartridges
- b) Pump diaphragms and valves
- c) Fuses
- d) Batteries
- e) Filter elements

Warranty is voided by abuse including mechanical damage, alteration, rough handling, or repair procedures not in accordance with the operator's manual. This warranty indicates the full extent of our liability, and we are not responsible for removal or replacement costs, local repair costs, transportation costs, or contingent expenses incurred without our prior approval.

THIS WARRANTY IS EXPRESSLY IN LIEU OF ANY AND ALL OTHER WARRANTIES AND REPRESENTATIONS, EXPRESSED OR IMPLIED, AND ALL OTHER OBLIGATIONS OR LIABILITIES ON THE PART OF RKI INSTRUMENTS, INC. INCLUDING BUT NOT LIMITED TO, THE WARRANTY OF MERCHANTABILITY OR FITNESS FOR A PARTICULAR PURPOSE. IN NO EVENT SHALL RKI INSTRUMENTS, INC. BE LIABLE FOR INDIRECT, INCIDENTAL, OR CONSEQUENTIAL LOSS OR DAMAGE OF ANY KIND CONNECTED WITH THE USE OF ITS PRODUCTS OR FAILURE OF ITS PRODUCTS TO FUNCTION OR OPERATE PROPERLY.

This warranty covers instruments and parts sold to users by authorized distributors, dealers, and representatives as appointed by RKI Instruments, Inc.

We do not assume indemnification for any accident or damage caused by the operation of this gas monitor, and our warranty is limited to the replacement of parts or our complete goods.

Table of Contents

Overview	1
Specifications	1
Description	2
Combustible Gas Detector	2
Amplifier	3
Junction Box	3
Installation	4
Mounting the Combustible Gas Transmitter	4
Wiring the Combustible Gas Transmitter	5
Startup	7
Introducing Incoming Power	7
Setting the Zero Signal	7
Maintenance	8
Preventive Maintenance	8
Troubleshooting	9
Replacing Components of the Combustible Gas Transmitter	10
Calibration Frequency	12
Calibration	13
Preparing for Calibration	13
Setting the Zero Reading	13
Setting the Response Reading	14
Returning to Normal Operation	14
Parts List	15

Overview

This manual describes the 65-2405RK combustible gas transmitter. This manual also describes how to install, start up, configure, maintain, and calibrate the transmitter when it is used with a gas monitoring controller. A parts list at the end of this manual lists replacement parts and accessories for the combustible gas transmitter.

Specifications

Table 1 lists specifications for the combustible gas transmitter.

Table 1: Specifications

Description	Specification
Target Gas	Combustible gas, methane calibration standard ¹
Area Classification	Explosionproof for Class I, Groups B, C, and D
Sampling Method	Diffusion
Signal Output	4 to 20 mA
Detection Range	0 to 100% LEL
Accuracy	± 5% of reading or ± 2% LEL (whichever is greater)
Response Time	90% in 45 seconds
¹ If calibration to a combustible gas other than methane is required, specify the required calibration gas at time of order.	

WARNING: *When using the 65-2405RK, you must follow the instructions and warnings in this manual to assure proper and safe operation of the 65-2405RK and to minimize the risk of personal injury. Be sure to maintain and periodically calibrate the 65-2405RK as described in this manual.*

Description

This section describes the components of the combustible gas transmitter. The transmitter is a 4 - 20 mA type detector head. It consists of the combustible gas detector, amplifier, and junction box.

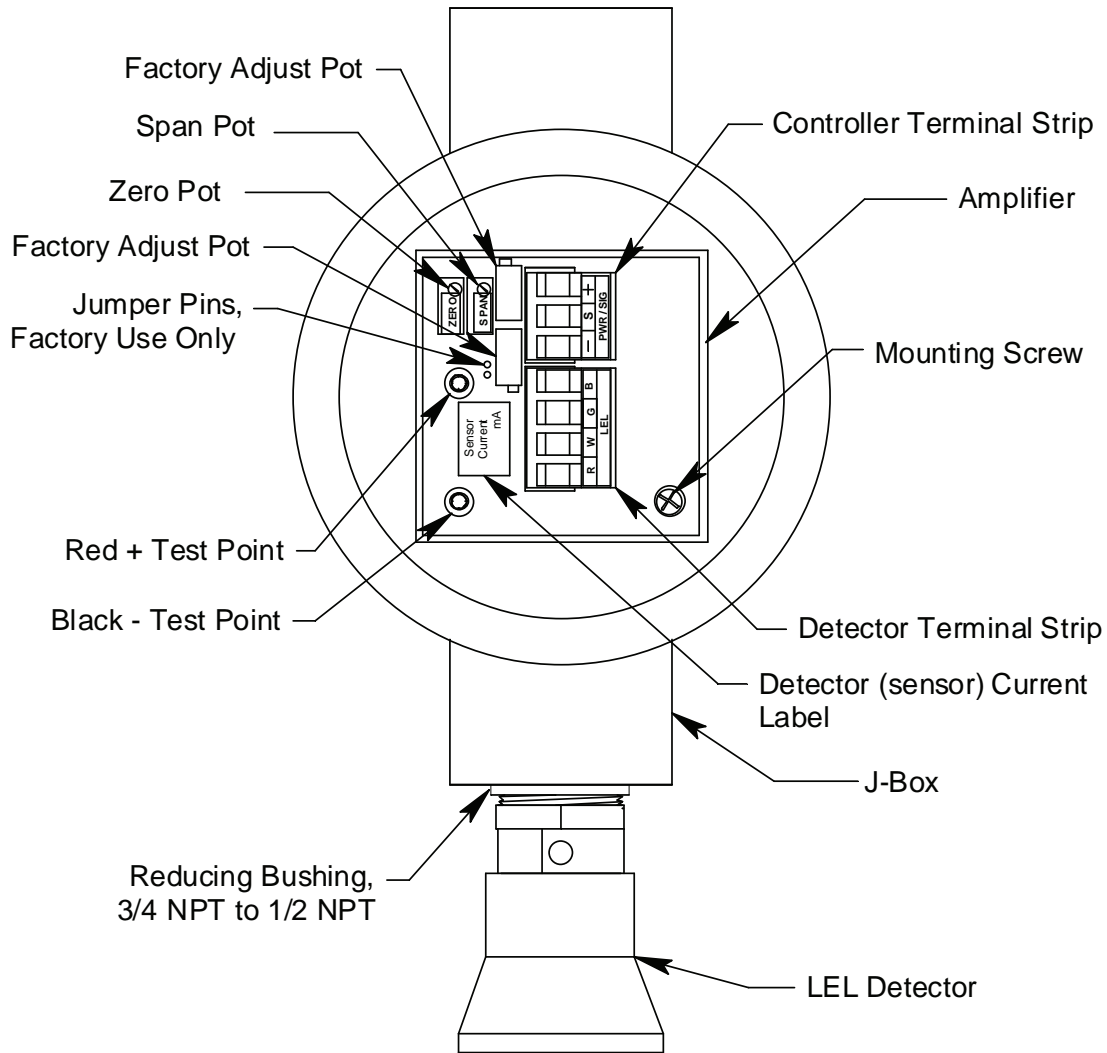

Figure 1: Combustible Gas Transmitter Component Location

Combustible Gas Detector

The combustible gas detector is a catalytic type detector that produces an electrical output that corresponds to the detection range. It is packaged in a 1/2 inch NPT nipple with a sintered metal flame arrestor on one end allowing ambient air to diffuse into the detector. The flame arrestor also contains any sparks which may occur within the detector. The 1/2 inch NPT mounting threads at the top of the detector allow you to mount it into the bottom conduit hub of the junction box. A rainshield screws onto the bottom of the detector (flame arrestor end). The rainshield helps protect the detector from rain and debris in the monitoring environment. Four color-coded leads extend from the top of the detector. The leads allow you to connect the detector to the amplifier.

Amplifier

The amplifier converts the electrical output from the detector to a 4 to 20 mA signal that corresponds to the detection range and transmits the signal to a gas monitoring controller. A foam gasket that orients the amplifier and keeps it from rotating is installed on the bottom of the amplifier. A label on the amplifier indicates the detector drive current. This drive current is factory set and is dictated by the combustible gas to which the detector is calibrated. Consult RKI Instruments, Inc. if you plan to change the calibration gas for the transmitter, for example from a methane calibration to a hexane calibration. The amplifier includes the detector terminal strip, controller terminal strip, span pot, zero pot, and test points (see Figure 1).

Controller Terminal Strip

The controller terminal strip is a three position plug-in style terminal strip located near the top of the amplifier. Use the controller terminal strip to wire the transmitter to a controller.

Detector Terminal Strip

The detector terminal strip is a four position plug-in style terminal strip located below the controller terminal strip. Use the detector terminal strip to connect the detector to the amplifier.

NOTE: The detector is factory-wired to the detector terminal strip. See the “Wiring the Combustible Gas Transmitter to a Controller” on page 5 for all wiring procedures related to the transmitter.

Zero Pot

The zero pot is located in the upper left corner of the amplifier (see Figure 1). Use a small flat blade screwdriver to turn the zero pot’s adjustment screw and adjust the amplifier’s zero (fresh air) output during the start-up and calibration procedures.

Span Pot

The span pot is located to the right of the zero pot (see Figure 1). Use a small flat blade screwdriver to turn the span pot’s adjustment screw and adjust the amplifier’s gas response output during the calibration procedure.

CAUTION: *The amplifier includes two additional potentiometers. They are factory-set. Do not adjust them.*

Test Points

The test points are on the left side of the amplifier (see Figure 1). The test points produce a 100 mV to 500 mV output that corresponds to the transmitter’s 4 to 20 mA output. Use the test points and a voltmeter to measure the amplifier’s output during the start-up and calibration procedures. The black test point in the lower left corner is the negative (-) test point and the red test point below the zero pot on is the positive (+) test point.

Junction Box

Use the junction box to install the transmitter at a mounting site that is remote from the controller. The junction box protects the amplifier and wiring connections made to the amplifier. Use the top 3/4 inch conduit hub to connect wiring from the amplifier to the controller. Use the cover on the front of the junction box to access the interior of the junction box. The detector and amplifier are factory installed in the junction box. Three spacers installed on the back of the junction box control the distance of the junction box

from a mounting surface and ensure that there is enough room to install a calibration cup on the detector during calibration.

Installation

This section describes procedures to mount the combustible gas transmitter in the monitoring environment and wire the transmitter to a controller.

Mounting the Combustible Gas Transmitter

1. Select a mounting site that is representative of the monitoring environment. Consider the following when you select the mounting site.
 - Select a site where the transmitter is not likely to be bumped or disturbed. Make sure there is sufficient room to perform start-up, maintenance, and calibration procedures.
 - Select a site where the target gas is likely to be found first. For lighter gases, mount the detector near the ceiling; for heavier gases, mount the detector near the floor.

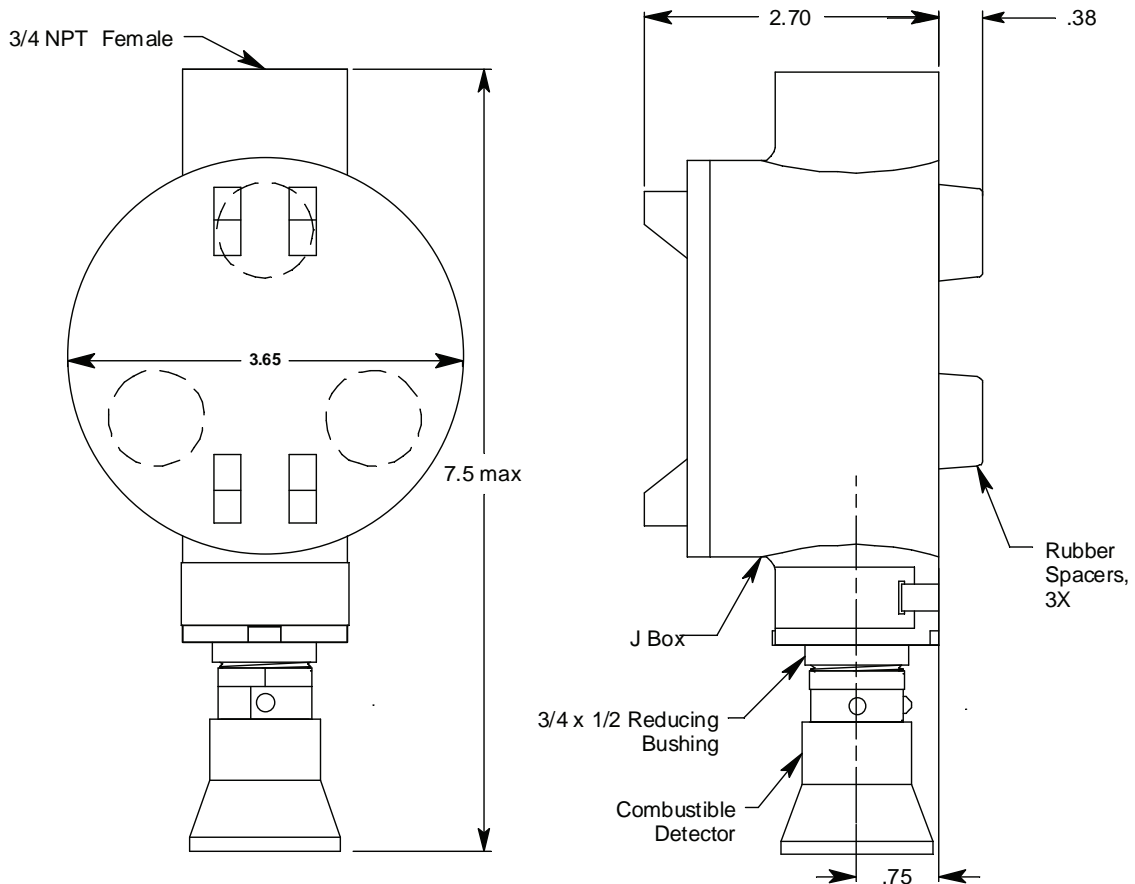

Figure 2: Mounting the Combustible Gas Transmitter

2. At the monitoring site you select, hang or mount the junction box with the detector facing down (see Figure 2).

Wiring the Combustible Gas Transmitter to a Controller

WARNING: *Always verify that the power to the controller is off before you make wiring connections.*

1. Turn off power to the controller.
2. Place the controller's power switch in the OFF position.
3. Remove the junction box cover.
4. The detector leads are factory wired. Verify that the detector leads are wired to the amplifier's detector terminal strip as shown in Figure 3.
5. To gain access to a plug-in terminal strip for wiring, pull it out of its socket by grasping the terminal strip and pulling. The detector strip is keyed so that the controller and detector terminal strips cannot be reversed inadvertently.
6. Guide a three-conductor, shielded cable or three wires in conduit through the top conduit hub of the junction box.
7. Pull out the controller terminal strip, and connect the three wires to the terminal strip as follows (see Figure 3).
 - Connect the positive wire to the **PWR/SIG “+”** terminal.
 - Connect the signal wire to the **PWR/SIG “S”** terminal.
 - Connect the negative wire to the **PWR/SIG “-”** terminal.

CAUTION: *If shielded cable is used, leave the cable shield's drain wire disconnected and insulated at the transmitter. You will connect the opposite end of the cable's drain wire to the controller's chassis (earth) ground.*

8. Reinstall the controller terminal strip into its socket.
9. Secure the junction box cover to the junction box.
10. Route the cable or wires leading from the combustible gas transmitter through one of the conduit hubs at the controller housing.

CAUTION: *Do not route power and transmitter wiring through the same controller conduit hub. The power cable may disrupt the transmission of the transmitter signal to the controller.*

11. Connect the wires to the applicable detector/transmitter terminal strip at the controller as shown in Figure 3

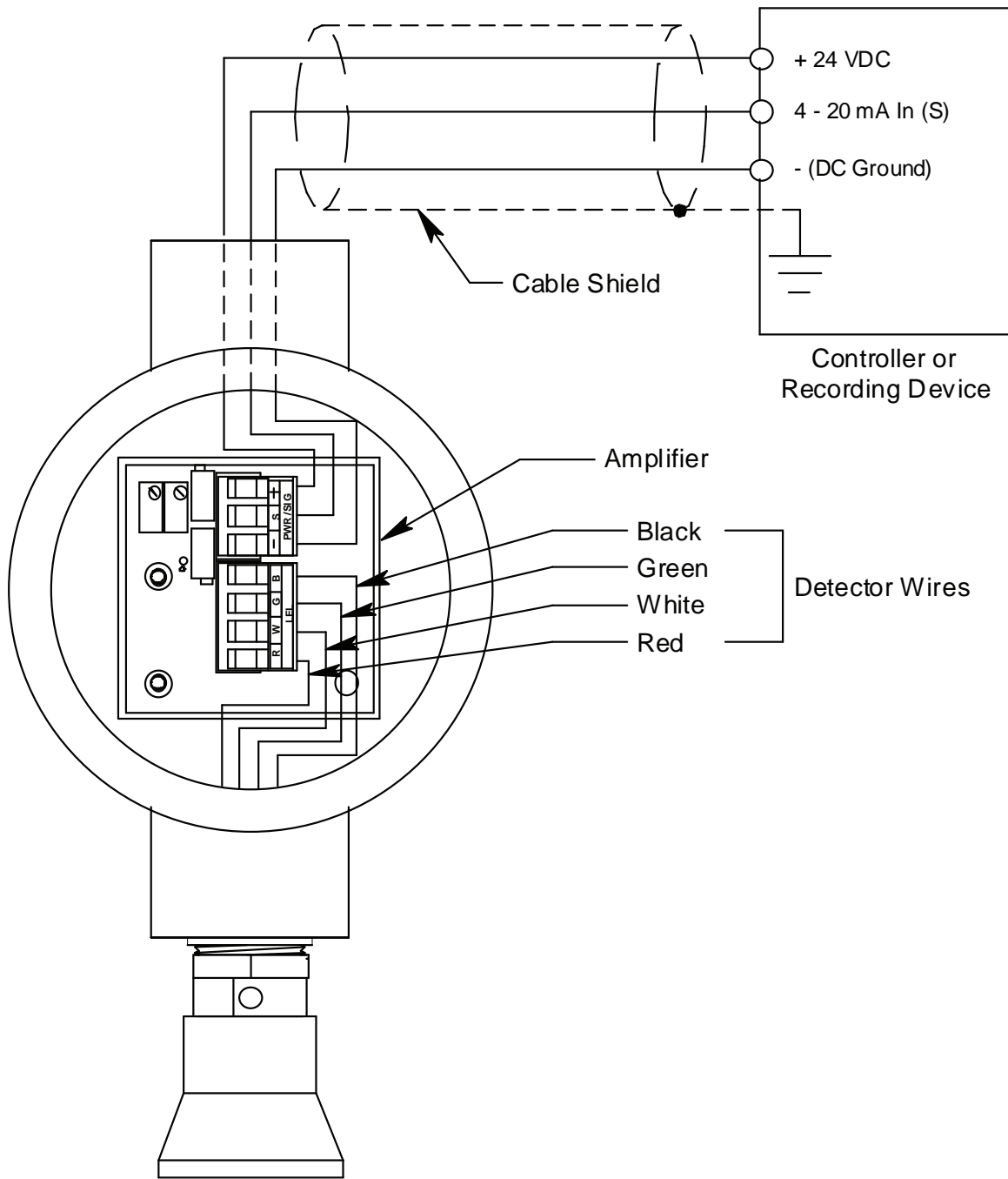

Figure 3: Wiring the Combustible Gas Transmitter to a Controller

12. If shielded cable is used, connect the cable's drain wire to an available chassis (earth) ground at the controller. RKI controllers typically have a ground stud that can be used to ground the cable's drain wire.

Start Up

This section describes procedures to start up the combustible gas transmitter and place the transmitter into normal operation.

Introducing Incoming Power

1. Complete the installation procedures described earlier in this manual.
2. Verify that the power wiring to the controller is correct and secure. Refer to the controller operator's manual.
3. Turn on power to the controller.
4. Turn on the controller.
5. Verify that the controller is on and operating properly. Refer to the controller operator's manual.

CAUTION: *Allow the detector to warm up for 5 minutes before you continue with the next section, "Setting the Zero Signal".*

Setting the Zero Signal

WARNING: *Do not remove the junction box cover while the circuits are energized unless the area is determined to be non-hazardous. Keep the junction box cover tightly closed during operation.*

CAUTION: *If you suspect the presence of combustible gas in the monitoring environment, use the calibration kit and the zero air calibration cylinder to introduce "fresh air" to the detector and verify an accurate zero setting. See "Calibration" on page 13 for instructions to apply zero air when setting the zero signal.*

1. Verify that the transmitter is in a fresh air environment (environment known to be free of combustible gas).
2. Unscrew and remove the junction box cover from the junction box.
3. Set a voltmeter to measure in the millivolt (mV) range.
4. Plug the voltmeter leads into the test points on the amplifier. Plug the positive lead into the red + test point; plug the negative lead into the black - test point.
5. Verify a voltmeter reading of 100 mV (± 2 mV).
6. If necessary, use a small flat-blade screwdriver to adjust the zero pot until the voltmeter reading is 100 mV (± 2 mV).
7. Remove the voltmeter leads from the test points.
8. Secure the junction box cover to the junction box.

Maintenance

This section describes maintenance procedures. It includes preventive maintenance, troubleshooting, and component replacement procedures.

Preventive Maintenance

This section describes a preventive maintenance schedule to ensure the optimum performance of the combustible gas transmitter. It includes daily, monthly, and quarterly procedures.

Daily

Verify a display reading of 0 %LEL at the controller. Investigate significant changes in the display reading.

Monthly

This procedure describes a test to verify that the combustible gas transmitter responds properly to the target gas.

WARNING: *The controller is not an active gas monitoring device during the response test procedure.*

NOTE: Performing a response test on the combustible gas transmitter may cause alarms. Be sure to put the controller into its calibration mode or disable external alarms before performing this test.

NOTE: The following procedure assumes the use of a calibration kit which includes a calibration gas cylinder, a 0.5 LPM fixed flow regulator with an on/off knob, a calibration cup for the detector, and a length of sample tubing.

Preparing for the response test

1. Place the controller into its calibration mode or disable external alarms.
2. Verify that the controller display reading for the channel you are testing is 0 %LEL.
If the display reading is not 0 %LEL, set the zero reading of the transmitter as described in “Start Up” on page 7, then continue this procedure.
3. Screw the calibration cup onto the bottom of the detector.
4. Use the calibration kit sample tubing to connect the regulator to the calibration cup.
5. Set a voltmeter to measure in the millivolt (mV) range.
6. Remove the junction box cover, then plug the voltmeter leads into the test points on the amplifier.
Plug the positive lead into the red + test point; plug the negative lead into the black - test point.

7. Use the following formula to determine the correct test points output for the test sample.

$$\text{Output (mV)} = (\text{calibrating sample/fullscale}) \times 400 + 100$$

For example, with a test sample of 50 %LEL and a fullscale setting of 100 %LEL, the correct output is 300 mV.

$$300 \text{ (mV)} = (50/100) \times 400 + 100$$

Performing the response test

1. Screw the regulator into the calibration cylinder.
2. Turn the regulator knob counterclockwise to open the regulator.
3. Allow the gas to flow for one minute.
4. Verify that the reading is within $\pm 20\%$ of the response reading you determined earlier.

NOTE: If the reading is not within $\pm 20\%$ of the correct response reading, calibrate the transmitter as described in “Calibration” on page 13 of this manual.

5. Turn the regulator knob clockwise to close the regulator.
6. Unscrew the regulator from the calibration cylinder.
7. Unscrew the calibration cup from the detector.

NOTE: For convenience, leave the regulator and calibration cup connected by the sample tubing.

8. Remove the voltmeter leads from the amplifier test points.
9. Reinstall the junction box cover.
10. When the controller display reading falls below the alarm setpoints, return the controller to normal operation.
11. Store the components of the calibration kit in a safe place.

Quarterly

Calibrate the combustible gas transmitter as described in “Calibration” on page 13 of this manual.

Troubleshooting

The troubleshooting guide describes symptoms, probable causes, and recommended action for problems you may encounter with the combustible gas transmitter.

NOTE: This troubleshooting guide describes transmitter problems only. See the controller operator’s manual for problems you may encounter with the controller.

Table 2: Troubleshooting the Combustible Gas Transmitter

Condition	Symptom(s)	Probable Causes	Recommended Action
Fail Condition	<ul style="list-style-type: none"> Controller indicates a fail condition. 	<ul style="list-style-type: none"> The transmitter wiring is disconnected or misconnected. The transmitter's zero reading is low enough to cause a fail condition. The transmitter is malfunctioning. 	<ol style="list-style-type: none"> Verify that the transmitter wiring is correct and secure. Calibrate the transmitter. If the fail condition continues, replace the detector. If the fail condition continues, contact RKI for further instruction.
Slow or No Response/ Difficult or Unable to Calibrate	<ul style="list-style-type: none"> Transmitter responds slowly or does not respond to response test. Unable to accurately set the zero or response reading during calibration. Transmitter requires frequent calibration. <p><i>Note: Under "normal" circumstances, the transmitter requires calibration once every 3 months.</i></p> <p><i>Some applications may require a more frequent calibration schedule.</i></p>	<ul style="list-style-type: none"> The calibration cylinder is low, out-dated, or defective. The calibration gas flow rate is too low. The calibration gas is not an appropriate concentration. The transmitter is malfunctioning. 	<ol style="list-style-type: none"> Verify that the calibration cylinder contains an adequate supply of a fresh test sample. Verify that the regulator used for calibration is a 0.5 LPM regulator. Verify that the calibration gas concentration is appropriate for the transmitter. The concentration should be in the detection range, preferably about half of the detection range. If the calibration/response difficulties continue, replace the detector. If the calibration/response difficulties continue, contact RKI for further instruction.

Replacing Components of the Combustible Gas Transmitter

This section includes procedures to replace the combustible gas detector and amplifier.

Replacing the Combustible Gas Detector

- Turn off power to the controller.
- Place the controller's power switch in the OFF position.
- Remove the junction box cover.
- Remove the detector terminal strip from its socket.
- Disconnect the detector leads from the detector terminal strip. Note the position of the color-coded leads as you remove them.
- Unscrew the detector from the junction box.
- Guide the detector leads of the replacement detector through the bottom conduit hub of the junction box, then screw the mounting threads of the detector into the conduit hub.

8. Connect the detector leads to the detector terminal strip as shown in Table 3 below and Figure 3 on page 6 of this manual.

Table 3:Reconnecting the Combustible Gas Detector to the Amplifier

Detector Lead	Detector Terminal Strip
Red	LEL "R"
White	LEL "W"
Green	LEL "G"
Black	LEL "B"

9. Turn on power to the controller.
10. Turn on the controller and place it into normal operation.

CAUTION: Allow the replacement detector to warm up for 5 minutes before you continue with the next step.

11. Calibrate the transmitter as described in "Calibration" on page 13 of this manual.

Replacing the Amplifier

1. Turn off power to the controller.
2. Place the controller's on/off switch in the OFF position.
3. Remove the junction box cover.
4. Unplug the detector terminal strip and controller terminal strip from their sockets. You may leave the wires connected to the terminal strips.
5. Unscrew and remove the screw with the flat and lock washers that secures the amplifier to the junction box.
6. Remove the old amplifier.
7. Install the amplifier into the junction box with the screw, lock washer, and flat washer you removed in Step 5 above. A foam gasket that orients the amplifier and keeps it from rotating is installed on the bottom of the amplifier. Make sure the amplifier is seated flat in the junction box.
8. Install the detector and controller terminals strips into their sockets on the new amplifier as shown in Figure 3 on page 6 of this manual. If controller leads or detector leads were removed during this procedure, refer to Table 4 and Table 5 below.

Table 4:Reconnecting the Amplifier to the Controller

Amplifier Controller Terminal Strip	Controller Transmitter Terminal Strip (typical)
PWR/SIG "-"	- (DC -)
PWR/SIG "S"	S (4 - 20 mA In)
PWR/SIG "+"	+ 24V

**Table 5:Reconnecting the LEL
Detector to the Amplifier**

Amplifier Detector Terminal Strip	Detector Lead
DETECTOR "R"	RED
DETECTOR "W"	WHT
DETECTOR "G"	GREEN
DETECTOR "B"	BLK

NOTE: When a transmitter is first powered up with a new amplifier, the initial output may be either high or below zero depending on the setting of the zero pot. Be sure to make arrangements so that this does not cause unwanted alarms.

9. Turn on power to the controller.
10. Turn on the controller and place it into normal operation.
11. Allow the transmitter to warmup for 5 minutes.
12. Calibrate the transmitter as described in "Calibration" on page 13 of this manual.

Calibration Frequency

Although there is no particular calibration frequency that is correct for all applications, a calibration frequency of every 3 to 6 months is adequate for most combustible gas transmitter applications. Unless experience in a particular application dictates otherwise, RKI Instruments, Inc. recommends a calibration frequency of every 3 months.

If an application is not very demanding, for example detection in a clean, temperature controlled environment where combustible gas is not normally present and calibration adjustments are minimal at calibration, then a calibration frequency of every 6 months is adequate.

If an application is very demanding, for example if combustible gas is present often and in significant concentrations or the environment is not well controlled, then more frequent calibration than every 3 months may be necessary. If potential catalyst poisons are known or likely to be present, more frequent calibration than every 3 months will be necessary.

Calibration

This section describes how to calibrate the combustible gas transmitter. It includes procedures to prepare for calibration, set the zero reading, set the response reading, and return to normal operation.

WARNING: *The controller is not an active gas monitoring device during the calibration procedure.*

NOTE: The following procedure assumes the use of a calibration kit which includes a calibration gas cylinder, a 0.5 LPM fixed flow regulator with an on/off knob, a calibration cup for the detector, and a short piece of sample tubing to connect the regulator to the calibration cup.

Preparing for Calibration

1. Screw the calibration cup onto the bottom of the detector.
2. Use the sample tubing to connect the regulator to the calibration cup.
3. Set a voltmeter to measure in the millivolt (mV) range.
4. Remove the junction box cover, then plug the voltmeter leads into the test points on the amplifier.

Plug the positive lead into the red + test point; plug the negative lead into the black - test point.

5. Use the following formula to determine the correct test points output for the calibrating sample.

$$\text{Output (mV)} = (\text{calibrating sample}/\text{fullscale}) \times 400 + 100$$

For example, with a calibrating sample of 50 %LEL and a fullscale setting of 100 %LEL, the correct output is 300 mV.

$$300(\text{mV}) = (50/100) \times 400 + 100$$

6. Place the controller into its calibration mode or disable external alarms.

NOTE: Calibrating the combustible gas transmitter may cause alarms. Be sure to put the controller into its calibration program or disable external alarms before continuing.

Setting the Zero Reading

NOTE: If you can verify that the combustible gas transmitter is in a fresh air environment, you do not need to apply zero air to the detector before adjusting the zero reading.

1. Screw the regulator into the zero air calibration cylinder.
2. Turn the regulator knob counterclockwise to open the regulator.
3. Allow the gas to flow for one minute and verify a reading of 100 mV (± 2 mV). If necessary, use the zero pot on the amplifier to adjust the reading to 100 mV (± 2 mV).

4. Turn the regulator knob clockwise to close the regulator.
5. Unscrew the regulator from the zero air calibration cylinder. Leave the sample tubing connected to the regulator and the calibration cup.

Setting the Response Reading

1. Screw the regulator into the calibration cylinder. Verify that the calibration gas is representative of the transmitter's target gas.
2. Turn the regulator knob counterclockwise to open the regulator.
3. Allow the calibration gas to flow for one minute and verify that the reading matches the response reading (± 2 mV) you determined earlier. If necessary, use the span pot on the amplifier to adjust the reading to match the correct response reading.
4. Turn the regulator knob clockwise to close the regulator.
5. Unscrew the regulator from the calibration cylinder.

Returning to Normal Operation

1. Remove the voltmeter leads from the amplifier test points.
2. Unscrew the calibration cup from the detector.

NOTE: For convenience, leave the regulator and calibration cup connected by the sample tubing.

3. Secure the junction box cover to the junction box.
4. When the controller display reading falls below the alarm setpoints, return the controller to normal operation.
5. Verify that the controller display reading decreases and stabilizes at 0 %LEL.
6. Store the components of the calibration kit in a safe and convenient place.

Parts List

Table 6 lists replacement parts and accessories for the combustible gas transmitter.

Table 6:Parts List

Part Number	Description
06-1248RK	Sample tubing (3/16 in. x 5/16 in.; specify length when ordering)
18-0001RK	Reducer, 3/4 in. NPT x 1/2 in. NPT
18-0400RK-01	Junction box with spacers
57-1053RK	Amplifier with gasket (specify target gas and that the 61-0140RK detector is being used when ordering)
61-0140RK	Combustible gas detector
65-2405RK	Combustible gas transmitter (includes detector and amplifier; specify target gas when ordering)
71-0132RK	<i>65-2405RK Combustible Gas Transmitter Operator's Manual (this document)</i>
81-0002RK-01	Steel calibration cylinder, 50% LEL hydrogen in air, 34-liter
81-0007RK-01	Steel calibration cylinder, 15% LEL hexane in air, 34-liter
81-0012RK-01	Steel calibration cylinder, 50% LEL methane in air, 34-liter
81-0076RK-01	Steel calibration cylinder, zero emission air, 34-liter
81-1050RK	Regulator, 0.5 liter/minute; with pressure gauge and flow control knob, for 17 liter and 34 liter steel calibration cylinders
81-1117RK	Calibration cup
81-F001RK-LV	Calibration kit, includes regulator, sample tubing, calibration cup, and 34 liter 15 %LEL hexane in air steel calibration cylinder
81-F002RK-LV	Calibration kit, includes regulator, sample tubing, calibration cup, and 34 liter 50 %LEL methane in air steel calibration cylinder
81-F004RK-LV	Calibration kit, includes regulator, sample tubing, calibration cup, and 34 liter 50 %LEL hydrogen in air steel calibration cylinder