



Safeguards and Precautions



1. Read and follow all instructions in this manual carefully, and retain this manual for future reference.
2. Do not use this instrument in any manner inconsistent with these operating instructions or under any conditions that exceed the environmental specifications stated.
3. This instrument is not user serviceable. For technical assistance, contact the sales organization from which you purchased the product or Monarch Instrument directly.



In order to comply with EU Directive 2002/96/EC on Waste Electrical and Electronic Equipment (WEEE): This product may contain material which could be hazardous to human health and the environment. DO NOT DISPOSE of this product as unsorted municipal waste. This product needs to be RECYCLED in accordance with local regulations, contact your local authorities for more information. This product may be returnable to your distributor for recycling - contact the distributor for details.

EXAMINER 1000 SPECIFICATIONS

Vibration Sensor:	Piezoelectric accelerometer 100 mV/g with magnetic base, probe and 5 foot cable to BNC
Display:	LCD 3.5 digit , measurement, hold, low battery indicator
Measurement	Acceleration 0.01-19.99 g (RMS)
Range:	Velocity 0.01-19.99 in/sec., 0.1-199.9 mm/sec (RMS) Envelope 0.01-19.99 ge (peak)
Frequency Range:	Overall 10 Hz - 10 kHz Envelope 0.5 kHz-10 kHz
Output:	Sensor Excitation: 18 Vdc @ 2 mA (BNC) Audio Out: 3.5 mm mini plug; 250 mW into 8 ohms, 150 mW into 32 ohms; Adjustable volume control with off position
Power:	(2) "AA" cells
Operating Time:	20 hours continuous without headphones
Weight:	Instrument: 7 oz. (0.19 kg); Complete Kit: 2.85 lb (1.30 kg)
Dimensions:	6.3 x 3.3 x 1.25" (152 x 83 x 32 mm)
Operating conditions:	-14° to 122°F (-10° to 50°C)



TABLE OF CONTENTS

OPERATING THE EXAMINER 1000

Overview	1
Controls and Functions.....	1
Rear Panel, Batteries and Connections	2
Parts of the System	3
Overview of Data Collection Procedure.....	3

APPLYING THE EXAMINER 1000

What is Predictive Maintenance?	4
Benefits of Predictive Maintenance	4
Why Measure Vibration?	5
Selecting Machinery & Measurements.....	6
Selecting Measurement Types	7
Getting Started in your Plant.....	8
Establishing a Data Collection Route.....	9
What are you Measuring?	10
Measurement Techniques	11
Evaluating overall Vibration Measurements	12
Evaluating Acceleration Envelope Measurements.....	13
GLOSSARY	14
Vibration Severity Chart per ISO 10816-1	16



OPERATING THE EXAMINER 1000

Overview

The **EXAMINER 1000** is designed to be used with vibration limits established in ISO Standard 10816 to help you detect signs of malfunction or changes in rotating machinery during operation. This is accomplished with overall vibration (ISO VIB) and envelope measurements. Problems with bearings occur when there is a microscopic crack or flaw or when there is a breakdown in lubrication which leads to metal-to-metal interaction. The **EXAMINER 1000** is designed to detect flaws or a lack of lubrication in bearings and gears at an early stage by measuring the high-frequency impacts through acceleration envelope methods.

Vibration measurements are made by pressing the accelerometer sensor against designated Measurement Points on your equipment with either the stringer probe or with the magnetic base.

Controls and Functions

ON/SELECT Button - Press this button to turn power *on*. Power automatically turns *off* after ten minutes of non-use. After turning the **EXAMINER "on"**, press the **ON/SELECT** button again to select the measurement type. Pressing and holding the **ON/SELECT** button while collecting data will **HOLD** the display value, indicated by the word "HOLD" in the display. To release from **HOLD** mode, press the **ON/SELECT** button again.

DISPLAY- The digital display shows the numerical value of the measurement. An arrow indicates the measurement type selected. The units of vibration are automatically displayed as the type of measurement is selected. The user may work in either metric or imperial units in the V-velocity mode.

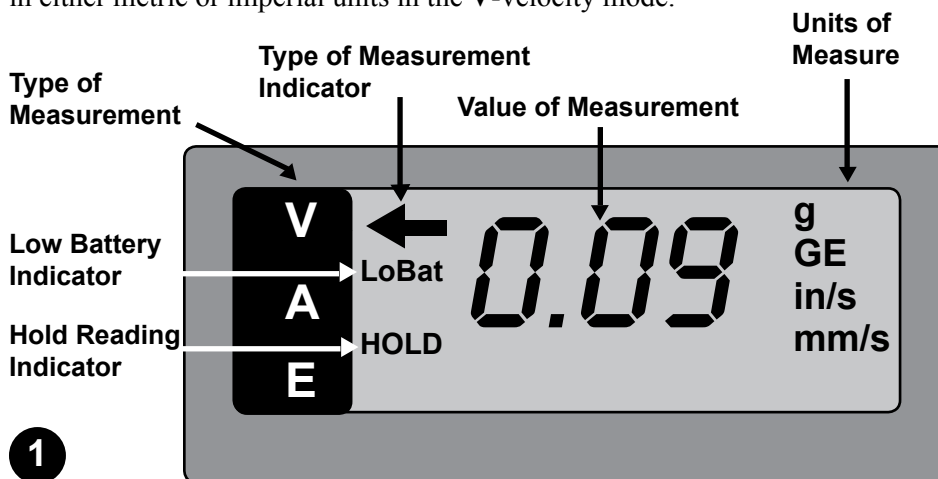

REAR PANEL CONNECTIONS

CONNECTIONS

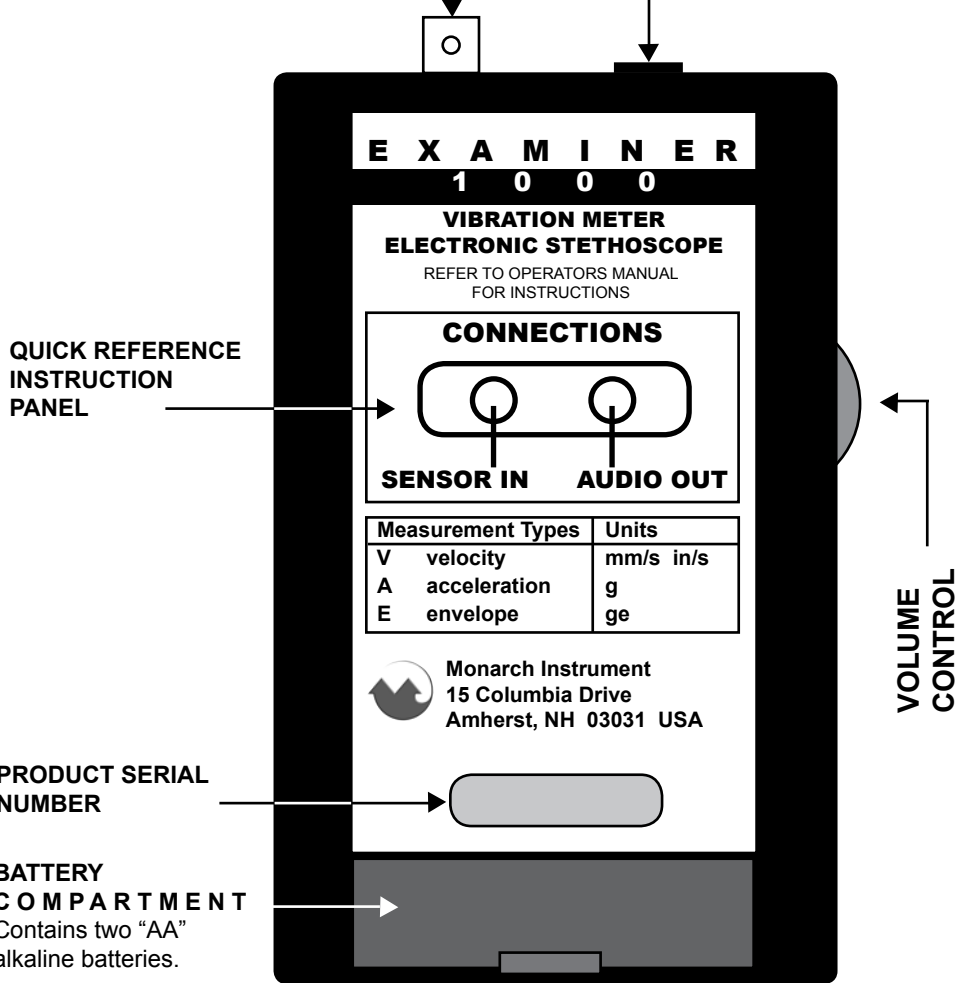

TOP VIEW

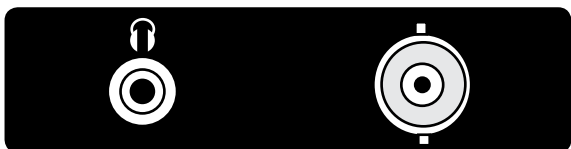

AUDIO OUT
1/8" (3.5 mm)
stereo mini plug

SENSOR INPUT
BNC Connector
output 18 vdc @ 2 mA

Parts of the System



Overview of Data Collection Procedure

1. Press the **ON/SELECT** button.
2. Press the **ON/SELECT** button again to select the desired measurement type. Place the accelerometer sensor on the machinery Measurement Point (use proper probe technique as discussed on the following pages).
3. Wait for the reading to stabilize, then press and hold the **ON/SELECT** button to "HOLD" the measurement. Indicated by **HOLD** in the display.
4. Adjust headphones volume level and listen for any distinct patterns or noises.
5. Record the measurement value in your *Machinery Data Worksheet*.
6. To release the **HOLD** function, press **ON/SELECT** again.
7. Repeat the above steps for each Measurement Point.



What Is Predictive Maintenance?

Predictive Maintenance can be defined as collecting information from machines as they operate to aid in making decisions about their health, repair and possible improvements in order to reach maximum runability, before any unplanned break-down. Machinery maintenance has evolved because of the demands to become more profitable through reduced maintenance costs. Below is the progression of these maintenance philosophies:

- **Break Down Maintenance**
- **Preventive Maintenance**
- **Predictive Maintenance**

Break Down Maintenance occurs when repair action is not taken on a problem until the problem results in the machines failure. Run to failure problems often cause costly secondary damage along with expenses resulting from unplanned downtime and unplanned maintenance.

Preventive Maintenance occurs when a machine, or parts of a machine, are overhauled on a regular basis regardless of the condition of the parts. While better than run to failure, preventive maintenance results in excessive downtime due to unnecessary overhauls and the excessive costs of replacing good parts along with worn parts.

Predictive Maintenance is the process of determining the condition of machinery as it operates, to predict and schedule the most efficient repair of problem components prior to failure. Predictive Maintenance not only helps plant personnel eliminate unplanned downtime and the possibility of catastrophic failure, but allows them effectively order parts, schedule manpower, and plan multiple repairs during *scheduled* downtime.

Benefits of Predictive Maintenance

Documented experience proves that plants which establish a predictive maintenance program are able to:

- **Improve Machinery Reliability**-reduced “unplanned failures”
- **Reduce Maintenance Costs**-knowing the exact problem to fix
- **Increase Production**-optimize machinery capabilities
- **Lower Energy Consumption**- less vibration usually means less friction
- **Extend Bearing Service Life**- reduce vibration and lubrication failures
- **Improve Product Quality**- where less vibration improves finish

The benefits are numerous and will vary depending upon the implementation of your Predictive Maintenance Program.



Why Measure Vibration?

Vibration is considered the best operating parameter to judge dynamic conditions such as balance (overall vibration), bearing defects (enveloping) and stress applied to components. Many machinery problems show themselves as excessive vibration. Rotor imbalance, misalignment, mechanical looseness, structural resonance, soft foundation, and gearmesh defects are some of the defects that can be measured by vibration. Measuring the “overall” vibration of a machine, a rotor in relation to a machine or the structure of a machine, and comparing the measurement to its normal value (norm) indicates the current health of the machine.

The **EXAMINER 1000** *measures* the vibration of a machine while it is operating. Trending these measurements shows how a machine’s condition changes over a period of time. Analyzing these, along with other measurements, provide insight into the condition of the machine and which components may be wearing or failing. How to best monitor a machine’s condition requires one to know which measurements to take and where and how to take them. *Sensors* are placed at strategic Points on the machinery to monitor the machine’s condition.

The **EXAMINER 1000** processes the accelerometer’s mechanical vibration energy into an electrical signal and displays the measurement value in numerical form for evaluation. Commonly measured physical characteristics in Predictive Maintenance are:

- **Vibration (as explained above)**
- **Temperature**
- **Oil Analysis**

Temperature

As a bearing fails, friction causes its temperature (or its lubricant’s temperature) to rise. While trending a bearing if the temperature rises followed by a vibration increase, then it is safe to conclude there was a loss of lubrication which induced the mechanical failure. If vibration increased first, followed by increased temperature readings then a mechanical defect caused the lubrication failure.

Lube Oil Analysis (Ferrography)

Monitoring oil condition warns of an increase in foreign substances, such as water, which can degrade the lubricating properties of the oil and cause bearing failures. It also detects the presence of metallic particles carried into the oil stream. These metallic particles are analyzed to determine which part of the machine is wearing and how fast. Lubrication analysis is the earliest warning of a developing problem. Lube oil testing results can be trended with **On-Time** software.

Selecting Machinery and Measurements

Maintenance personnel have always made visual and hands-on inspections of their machinery on a periodic basis. Systematic data collection and trending allows for recall and comparison of events over time but is not a replacement for good maintenance practices. Collecting machinery data is an **aid** to the maintenance professional, which is used in addition to good maintenance practices.

Selecting and Classifying Machinery

Setting up an effective Predictive Maintenance Program requires a careful study of the needs of the plant. It is necessary to know each machine and its response to change. The following is an example of machinery classification:

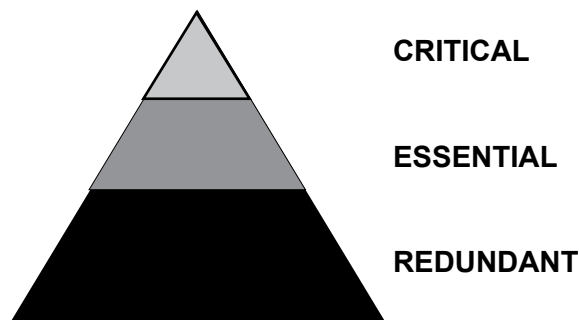

Critical Machines expensive premium equipment, generally >500 HP. Usually less than 5% of all plant equipment. Maintenance dollars per horsepower per year average \$11.00. This category of equipment is very well maintained and monitored. Continuous monitoring systems are better suited for this type of equipment.

Essential Machines medium size equipment, 100-500 HP. This group may be 30-40% of all the equipment in the plant. Maintenance costs can average \$22.00 per horsepower per year. Less attention is paid to these machines even though their repair costs can be as high as critical machines. Select some of these machines for your Predictive Maintenance Program.

Redundant Machines small redundant equipment usually < 100 HP. This group can be as much as 50% of all machines in a plant and yet they are usually neglected. By far the **most expensive to maintain** at \$49.00/HP/year, this group **will benefit the most from Predictive Maintenance practices**. At many facilities, this group consumes 80% of the annual maintenance budget. If you want to have an immediate impact begin with these machines. Also include machines with known problems or a history of problems. **Personnel Safety is always the first priority in selecting machinery to monitor.**



Selecting Measurements

Establish measurement types that most accurately reflect the condition of the equipment. Different causes or “**mechanisms**” are acting on the machine; various types of measurements have been developed to measure each type of mechanism. Those mechanisms are:

Stress A force on the machine or components which deflects the part. Best measured in **Displacement**. The **Examiner 1000** does not measure Displacement as it is a very low vibration frequency, below 10 Hz (600 RPM).

Fatigue Repeated cycles of stress on a component. If you bend a part back and forth enough times it will fatigue. As a general rule, fatigue failures result from vibration frequencies 10 -2000 Hz and **Velocity** measurements are used. **Velocity will be the primary measurement taken.**

Force Mass x acceleration. Measured in **Acceleration**. Acceleration is the rate of change of velocity. Acceleration is used for high frequencies above 2000 Hz (120,000 RPM). Bearing defects and gearmesh frequencies are usually found in this range.

Impact forces The result of fatigue. Impact forces are cyclical events which can be detected with **Acceleration Enveloping**. These are high frequency-low amplitude events and a filter in the **EXAMINER 1000** is set at 10-30 kHz to measure them.

Types of Measurements in the EXAMINER 1000

Velocity- Good for frequency ranges 10-2000 Hz (600-120,000 RPM).

Acceleration-used for higher frequencies or speeds above 2000 Hz (120,000 CPM).

Acceleration Enveloping-uses a high pass filter to measure high-frequency, repetitive bearing and gearmesh vibration signals. Used for early detection of developing bearing or lubrication problems. Use this type in combination with the other types to detect changes in machinery.

Select Measurement Intervals

Based on the classification of the machine, its repair history and the amount of data required for a detailed trend analysis. At the beginning of a Predictive Maintenance Program, collect data frequently to build a rapid history of each machine. Adjust your program as you go. ***If measurement results are indicating signs of change, measurements should be performed more frequently.***

Getting Started in Your Plant

Planning your work is very important to achieve success. The **EXAMINER 1000** is an overall vibration meter and electronic stethoscope. It can be used as a stand alone device for the collection of vibration data for the purposes of trending or as a diagnostic instrument used to troubleshoot machinery defects. In order to setup a trending program you must collect data on the same point with the same measurement type at a defined interval. The *Machinery Data Worksheet* allows for record keeping of collected data. The **EXAMINER** may be used with the **On-Time** software to store data and perform trend analysis. **REPEATABILITY IS REQUIRED FOR ACCURATE TRENDING.**

Establish a standard naming convention so you can communicate your results to the rest of maintenance. Vibration readings are taken on the bearing caps or as close to the bearings as possible. Always collect data the same way, at the same point on the machine each time.

Direction for placing the Sensor

For Vertical and Horizontal readings, the sensor is placed in a radial position.

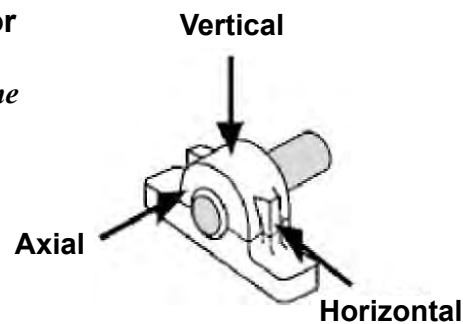

Also establish a starting point for each machine. Begin from the **OUTBOARD END** of the **DRIVE UNIT**, calling this point **A**. Proceed to label Points (bearings) as needed until you have reached the outboard end of the driven unit.

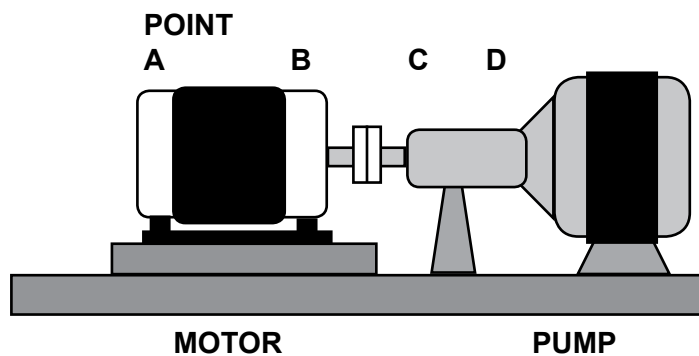

Establishing a Data Collection Route

The **Machinery Data Worksheet** helps organize data for routine data collection. Vibration readings are taken on the Points (bearings) established in your route and recorded using your naming convention on the worksheet. Vibration, speed, temperature, pressure or any process data may be recorded using this type of systematic approach.

Steps for Route collection

1. Determine the machines which require data collection.
2. Define each measurement type for data collection Points on each Machine. Several Points will have numerous readings i.e. VEL and ENV and Temp.
3. Establish a Route with the Machines grouped by physical location.
4. Walk the Route, collecting and recording data for each Point.
5. Transfer data values to your **On-Time Trending** software.

Recording Data for a Machine

The vibration sensor is placed on each data collection Point. The Point, direction of the sensor and the value are recorded on the Machinery Data Worksheet.

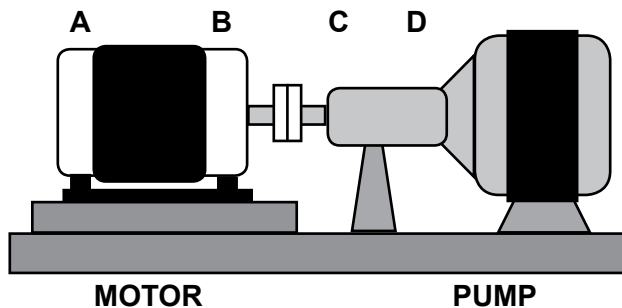

example of Machinery Data Worksheet

Point **AVV** is taken on the outboard end of the motor, in the vertical position with a velocity type reading.

AHV -Point A in the horizontal position with a Velocity type.

Machine Identification <u>Water Pump #707</u>				
Machine Description <u>AC motor 1800 RPM, flexible coupling, 3 vane pump. CAUTION HOT WATER!!!</u>				
Date	Point	Direction	Type	Value
Jan 2 1999	A	V	V	0.06 in/s
Jan 2 1999	A	H	V	0.04 in/s
Jan 2 1999	A	X	V	0.03 in/s
Jan 2 1999	B	V	V	0.07 in/s
Jan 2 1999	B	H	V	0.05 in/s
Jan 2 1999	B	V	Env	0.001 ge



What are you Measuring?

Vibration is the behavior of a machine's mechanical components as they react to internal or external forces. Since most rotating machinery problems show themselves as excessive vibration, we use vibration signals as an indication of a machine's mechanical condition. Also, each mechanical problem or defect generates vibration in its own unique way. We therefore analyze the "type" of vibration to identify its cause and take appropriate repair action. With overall vibration monitoring (VIB ISO) using the **Examiner 1000**, analysis of the cause of excess vibration relates to the monitoring equipment's probe position; either horizontal, vertical, or axial.

Horizontal - Typically, *unbalanced* shafts tend to cause excess radial (horizontal and vertical) vibrations, depending on the machine support design.

Vertical - Excessive vertical vibration can indicate mechanical looseness as well as imbalance.

Axial - Excessive axial vibration is a strong indicator of misalignment.

It's important to note that these are general guidelines and that knowledge of your machinery and proper hand-held probe techniques are necessary to accurately analyze the cause of excessive vibration.

Multi-Parameter Monitoring

Using different measurement types to monitor your machinery for changes. This allows for early detection of specific machinery problems that may not show under normal overall vibration monitoring. For example, if a rolling element bearing has a defect on its outer race, each roller will strike the defect as it goes by and cause a small, *repetitive* vibration signal. However, this vibration signal is of such low amplitude that under normal overall vibration monitoring, it is lost in the machine's rotational and structural vibration signals. Acceleration Enveloping can measure these signals better than overall readings. **Use both measurement types for bearings and gearboxes. As ENV values begin to decrease, rely on VEL readings.**

Overall Vibration Monitoring - Monitors normal, low frequency machine vibration. Detects rotational and structural problems like imbalance, misalignment, and mechanical looseness.

Enveloping - Amplifies high-frequency, repetitive bearing and gear mesh vibration signals for *early detection of bearing problems*, but does not detect non-repetitive rotational or structural events like imbalance, misalignment, and looseness. Provides *earliest detection* of high frequency metal-to-metal contact or poor lubrication in problem bearings.



Measurement Techniques

In general, vibration of anti-friction bearings is best monitored in the load zone of the bearing. Equipment design often limits the ability to collect data in this zone. Simply select the measurement Point which gives the best signal. Avoid painted surfaces, unloaded bearing zones, housing splits, and structural gaps. When measuring vibration with a hand-held sensor, it is very important to collect **consistent** readings, paying close attention to the sensor's position on the machinery, the sensor's angle to the machinery, and the contact pressure with which the sensor is held on the machinery.

- **Location** - always collect at the same point on the machine. Mark locations.
- **Position** - Vibration should be measured in three directions:
 - A** axial direction
 - H** horizontal direction
 - V** vertical direction
- **Angle** - Always perpendicular to the surface ($90^\circ \pm 10^\circ$).
- **Pressure** - Even, consistent hand pressure must be used (firm, but not so firm as to dampen the vibration signal). For best results use the magnetic base. If using the stinger/probe is the only method available to collect data, it is best to use a punch to mark the location for the probe-tip to ensure a consistent coupling to the housing.

Optimum Measurement Conditions

Perform measurements with the machine operating under normal conditions. For example, when the rotor, housing, and main bearings have reached their normal steady operating temperatures and with the machine running under its normal rated condition (for example, at rated voltage, flow, pressure and load). On machines with varying speeds or loads, perform measurements at all extreme rating conditions in addition to selected conditions within these limits. The maximum measured value represents the vibration severity.

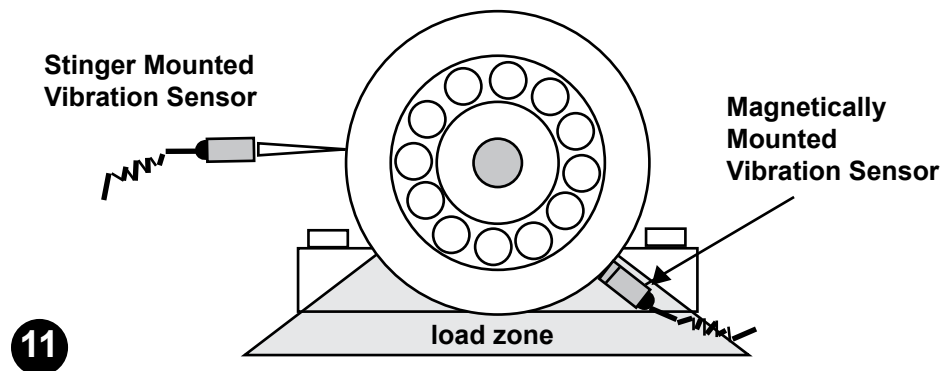

Evaluating the Overall Vibration Measurements

Three general principles are commonly used to evaluate your vibration measurement values:

ISO 10816 Standard Comparison - Compare values to the limits established in the ISO 10816 Standard. See Vibration Severity Chart on page 16.

Trend Comparison - Compare current values with values of Baseline for the same Points over a period of time.

Comparison with Other Machinery - Measure several machines of a similar type under the same conditions and judge the results by mutual comparison.

If possible, you should use all three comparisons to evaluate your machinery's condition. ISO 10816 and trend comparisons should always be used.

ISO 10816 Standard Comparison

The ISO 10816 Standards provide guidance for evaluating vibration severity in machines operating in the 10 to 200 Hz (600 to 12,000 RPM) frequency range. Examples of these types of machines are small, direct-coupled, electric motors and pumps, production motors, medium motors, generators, steam and gas turbines, turbo-compressors, turbo-pumps and fans. Some of these machines can be coupled rigidly or flexibly, or connected through gears. The axis of the rotating shaft may be horizontal, vertical or inclined at any angle.

Machinery class designations are:

Class I

Individual parts of engines and machines, integrally connected with the complete machine in its normal operating condition. (Production electrical motors of up to 20 HP (15 kW) are typical examples of machines in this category.)

Class II

Medium-sized machines typically, electric motors with 20 to 75 HP (15-75 kW) without special foundations, rigidly mounted engines, or machines on special foundations up to 400 HP (300 kW).

Class III

Large prime movers and other large machines with rotating masses mounted on rigid and heavy foundations which are relatively stiff in the direction of vibration measurement.

Class IV

Large prime movers and other large machines with rotating masses mounted on foundations which are relatively soft in the direction of vibration measurement (for example, turbo-generator sets, especially those with lightweight structures).

Note: These ISO 10816 Standard classes do not apply to prime movers or driven equipment in which the major working components have a reciprocating motion.



Trend Comparison

The most efficient and reliable method of evaluating vibration severity is to compare the most recent reading against previous readings for the same measurement Point, allowing you to see how the Point's vibration values are "trending" over time. This trend comparison between present and past readings is easier to analyze when the values are plotted in a "trend plot". A trend plot displays current and past values plotted over time. Measurement records should also include a baseline (known good) reading. The baseline value may be acquired after an overhaul or when other indicators show that the machine is running well. Subsequent measurements are compared to the baseline to determine machinery changes.

Comparison with Other Machinery

When several similar machines are used under the same operating conditions, evaluation can be carried out by measuring all machines at the same Points and comparing the results.

Evaluating Acceleration Envelope Measurements

Use the same techniques of comparison as for Overall Vibration readings. Remember, acceleration envelope is an advanced "*early warning*" of a developing problem. High values do not necessarily indicate bearing failure. They can also indicate:

- A. Lack of lubrication or decreasing oil viscosity due to high bearing temperature caused by overload or external heat source.
- B. Breaking of the lubricant film by excessive imbalance, misalignment, or housing deformation. Loss of boundary lubrication.
- C. A rubbing seal or cover.
- D. Gear mesh interaction (bad lubrication, defects)
- E. Dirt or particles in the lubricant, or a seal or filter problem.

Use trend Comparison similar to overall vibration to establish severity levels.

Accelerating Envelope readings tend to decrease as Overall Vibrations readings increase. This happens when the defect in the bearing is becoming more severe and the frequency it generates becomes lower which makes it better read with the Velocity-type readings.

Audio Comparison with Other Bearings on the Same Machinery

When several bearings are used under the same operating conditions, evaluation can be carried out by listening to the audio signals to determine changes. This method will help to locate the defective bearing quickly. Measure all machines at the same Points and compare the results. Listen for increases in signal and for "clicking" patterns which indicate wear.



GLOSSARY (for vibration purposes)

- Acceleration** A scalar quantity that specifies time rate of change of velocity. Expressed in either g's or m/sec² where 1 g = 386.1 in/sec² and 9.8066 m/sec².
- Acceleration Enveloping** A high-frequency, filtered data collection method expressed in ge.
- Accelerometer** A transducer which converts acceleration motion in to an electrical output.
- Amplitude** The magnitude of vibratory motion. Can be measured as peak-to-peak, zero-to-peak, or RMS.
- Axial** The direction parallel to the axis of rotation.
- Baseline** Recorded values taken when a machine is known to be good. The standard which all additional readings will be compared to.
- CPM** Unit of frequency measurement-cycles per minute.
- Displacement** A scalar quantity specifying the change of position of a body measured from the resting position.
- Dynamic Force** A force that varies with time.
- Force** Energy applied to a mass producing a deflection (static force) or motion (dynamic force).
- Frequency** The repetition rate of a periodic event, expressed in cycles per second (Hz), CPM, RPM, or multiples of running speed (orders).
- g's** Units of acceleration referenced against the force of gravity.
(1g=32.1739 ft./sec/sec; 1g=9.8066 m/sec/sec)
- Gear Mesh Frequency** A frequency generated by a gear. Defined as the number of gear teeth on a gear times its shaft-rotating frequency.
- Hertz (Hz)** A unit of frequency measurement, cycles per second.
- High-pass Filter** A filter that allows only those components above a selected frequency to pass.
- Integration** The time-based process of converting acceleration and velocity to velocity or displacement.
- in/sec, ips** Abbreviations for inches per second, a measure of velocity.
- Mass** The measure of body resistance to acceleration. Proportional to, but not equal to, weight (mass = weight/gravity).
- Measurement Point** A location on a machine or component where all subsequent measurements should be made for accurate comparison.
- Mechanical Impedance** Ratio of applied force to resulting velocity during simple harmonic excitation.
- Overall** The amplitude of vibration within a specified frequency range.
- Peak Value** The absolute value zero to the maximum excursion on a dynamic waveform. Also true peak and zero-to-peak.
- Periodic Monitoring** Measurements recorded at intervals of time.



GLOSSARY (for vibration purposes)

Piezoelectric	A material in which electrical properties change when subjected to force.
Process Measurements	Variables such as temperature, pressure, speed and flow used to assess internal conditions of efficiency.
Radial	Direction perpendicular to the shaft centerline.
Repeatability	A measure of the deviation between successive measurements made under the same conditions.
RMS	Peak Vibration x .707. (in/s or mm/s)
Rolling Element Bearing	A bearing consisting of balls or rollers operating between fixed and rotating races.
Route	A sequence of measurements arranged for convenience during acquisition.
Sensitivity	Used to describe a transducer's electrical output for a unit variation of the mechanical quantity measured.
Stress	Force per unit area
Synchronous	Frequency components that are an integer multiple of running speed.
Transducer	A system consisting of a sensor and signal conditioner to convert a physical quantity into an output for display, monitoring and analysis.
Transmission Path	The path from source (excitation) to sensor.
Trending	The plot of a variable over time used as an indicator of change.
Velocity	A vector quantity of the time rate change of displacement.

Vibration Conversions

$$D = 19.10 \times 10^3 \times (V/F)$$

$$D = 70.4 \times 10^6 \times (A/F^2)$$

$$V = 52.36 \times 10^{-6} \times D \times F$$

$$V = 3.68 \times 10^3 \times (A/f)$$

$$A = 14.2 \times 10^{-9} \times D \times F^2$$

$$A = 0.27 \times 10^{-3} \times V \times F$$

where: **D = Displacement (mils peak-to-peak)**
 V = Velocity (in/s zero-to-peak)
 A = Acceleration (in/s² zero-to-peak)
 F = Frequency (cpm)

Use the chart below as a guide to judge the overall vibration severity of your equipment. Refer to page 12 for further details.

VIBRATION SEVERITY PER ISO 10816-1					
Machine		Class I small machines	Class II medium machines	Class III large rigid foundation	Class IV large soft foundation
in/s	mm/s				
Vibration Velocity Vrms	0.01	0.28			
	0.02	0.45			
	0.03	0.71		good	
	0.04	1.12			
	0.07	1.80			
	0.11	2.80		satisfactory	
	0.18	4.50			
	0.28	7.10		unsatisfactory	
	0.44	11.2			
	0.71	18.0			
	1.10	28.0		unacceptable	
	1.77	45.0			