

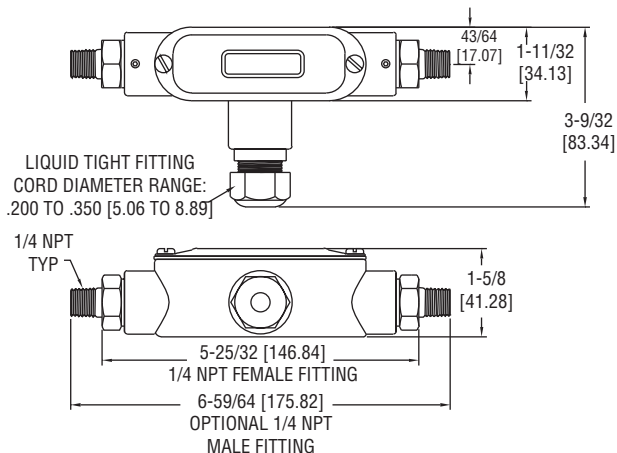

Series 629 Differential Pressure Transmitter

Specifications - Installation and Operating Instructions



The Series 629 Differential Pressure Transmitter monitors differential pressure of air and compatible gases and liquids with 0.5% accuracy. The design employs dual pressure sensors converting pressure changes into a standard 4-20 mA output signal for two wire circuits. Small internal volume and minimum moving parts result in exceptional response and reliability. Terminal block, zero and span adjustments are easily accessed under the top cover. The Series 629 Differential Pressure Transmitter is designed to meet NEMA-4X (IP66) construction.

Range (psid)	Pressure Limits	
	Working*	Over
	Pressure (psi) Max. Static on Either Port	Pressure (psi)
5	10	50
10	20	100
25	50	250
30	60	250
50	100	250
100	200	500
150	300	750
200	400	1000
300	600	1200
500	1000	2000

* Pressures exceeding the working pressure limit may cause a calibration shift of up to $\pm 3\%$ of full scale.

SPECIFICATIONS

Service: Compatible gases & liquids.
Wetted Materials: Types 316, 316L SS.
Accuracy: $\pm 0.5\%$ F.S. (includes linearity, hysteresis & repeatability).
Temperature Limits: 0 to 200°F (-18 to 93°C).
Compensated Temperature Limits: 0 to 175°F (-18 to 79°C).
Pressure Limits: See chart.
Thermal Effect: 0.02%/°F (0.036%/°C) includes zero & span.
Power Requirements: 13-30 VDC.
Output Signal: 4 to 20 mA. Optional 0-5, 1-5, 0-10, 1-6 or 2-10 VDC.
Zero & Span: Potentiometers inside conduit enclosure.
Response Time: 50 msec.
Loop Resistance: 0-1300 ohms maximum for current output. For voltage outputs, minimum load resistance: 2000 ohms.
Current Consumption: Transmitter: 40 mA max; Transmitter with optional display: 140 mA max.
Electrical Connections: Terminal block.
Process Connections: 1/4" female NPT.
Display: Optional 4-1/2 digit 1/2" (12.7 mm) height LED.
Enclosure Rating: Designed to meet NEMA 4X (IP66) for non-LED models.
Mounting Orientation: Not position sensitive.
Weight: 10.1 oz (286 g).
Agency Approvals: CE:
 EN 61000-4-2
 EN 61000-4-3
 EN 61000-4-4
 EN 61000-4-5
 EN 61000-4-6

INSTALLATION

1. Location: Select a location where the temperature of the unit will be between 0°F and 175°F. Distance from the receiver is limited only by total loop resistance (see electrical connections). The tubing feeding pressure to the instrument can be practically any length required, but long lengths will increase the response time slightly. Mount the instrument in a location that will not be subject to excessive temperature, shock or vibration.

2. Position: A vertical position is recommended (pressure connections pointing horizontally) since that is how all standard models were originally spanned and zeroed at the factory. They can be used at other angles, but may require final spanning and zeroing. Due to potential condensation build up that may travel down conduit or cable and into the housing, it is recommended to install with the electrical conduit or cable gland pointing downward.

3. Pressure Connection: Dual 1/4" female NPT pressure connections are provided. Use pipe thread sealant tape or other suitable pipe joint compound when making connection to the pressure source. Avoid excess sealant which could block the pressure passage. When monitoring liquid pressures, air trapped in the lines can cause incorrect readings. Bleed fittings or similar mechanisms should be used to bleed off any trapped air.

Optional 3-Way Valve

For applications where higher line pressures may be encountered at installation or when it is necessary to remove the transmitter for maintenance without interrupting the process, the optional three way valve is recommended (See Fig. A).

Begin with valve V1 open and valves V2 and V3 closed (See Fig. B). Slowly open valves V2 and V3. Once the pressure has stabilized and is equal on the high and low side of the transmitter, valve V1 can be closed and normal operation can proceed.

To ensure proper pressures will be detected by the 629 use the bleed fitting provided with this package to free media of bubbles. Before applying pressure to the process connections, turn V1 to the open position and back off the bleed screw. Next apply pressure. After the flowing liquid is free of bubbles, retighten the bleed screw.

Before removing the transmitter from operation, open valve V1 then close valves V2 and V3.

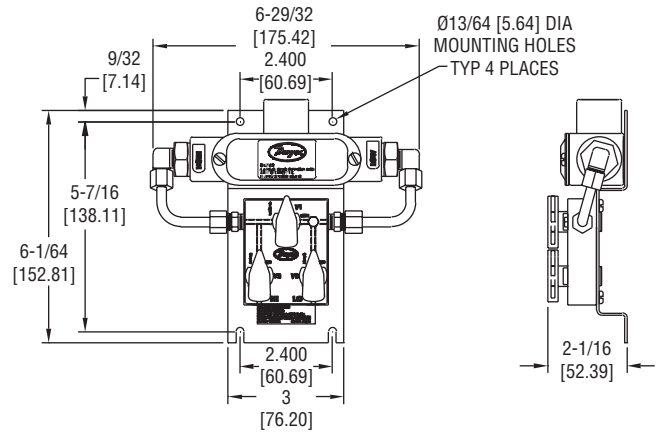

Fig. A

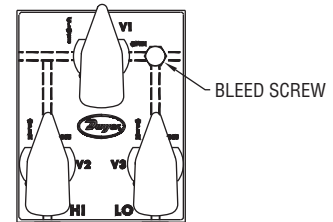

Fig. B

ELECTRICAL CONNECTIONS

Shielded cable is recommended for control loop wiring.

Current Output

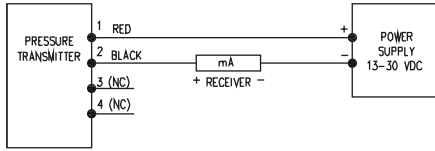

Fig. C: Current output connection

Electrical connections to the Series 629 pressure transmitters are made to the terminal block located inside the housing. Remove the screws and lift off the cover. Wire as shown in Fig. C, D or E. Use Fig. C for current output connection. Use Fig. D for current output with optional LED display. Use Fig. E for current output with optional LED display using two power supplies. If ordering pre-wired cable, black wire is negative (-) and red wire is positive (+).

Wire Length - The maximum length of wire connecting transmitter and receiver is a function of wire size and receiver resistance. Wiring should not contribute to more than 10% of receiver resistance to total loop resistance. For extremely long runs (over 1000 ft.), choose receivers with higher resistance to minimize size and cost of connecting leads. When the wiring length is under 100 feet, lead wire as small as 22 AWG can be used.

Current (4-20 mA) Output Operation - An external power supply delivering 13-30 VDC with minimum current capability of 40 mA DC (per transmitter) is required to power the control loop. See Fig. C for connection of the power supply, transmitter, and receiver. The range of the appropriate receiver load resistance (R_L) for the DC power supply voltage available is expressed by the formula:

$$R_L \text{ Max} = \frac{V_{ps} - 13}{20 \text{ mA DC}}$$

VOLTAGE (0-5, 1-5, 0-10, 1-6 or 2-10 Volt) OUTPUT OPERATION

For voltage outputs, wire as shown in Fig. F or Fig. G. Use Fig. F for voltage output connection. Use Fig. G for voltage output with optional LED display. Terminal 1 is positive (+), terminal 2 is negative (-), terminal 3 is +Vout, terminal 4 is LED positive supply. If ordering optional pre-wired cable, black wire is negative (-), red wire is positive (+) and white wire is +Vout.

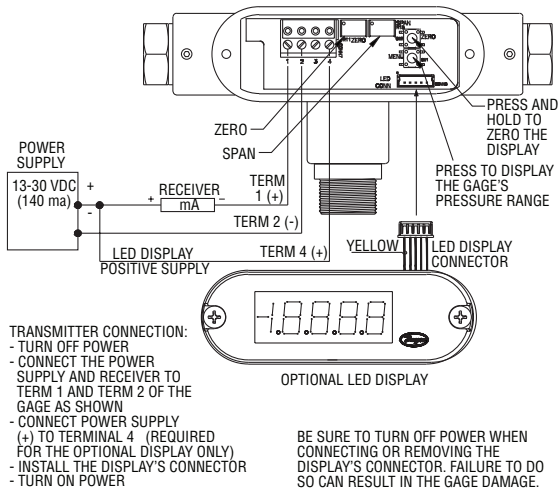

Fig. D: Current output with optional LED display

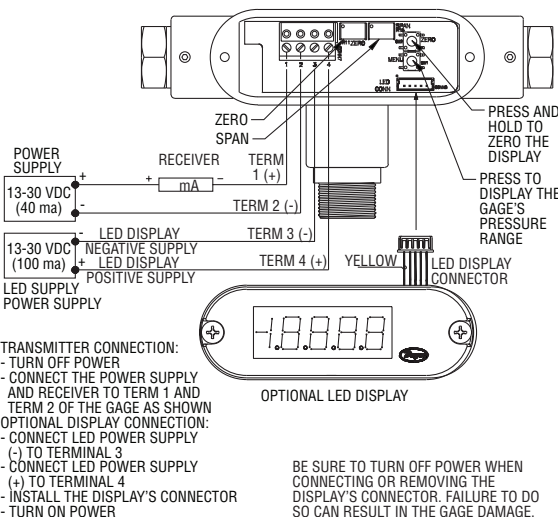

Fig. E: Current output with optional LED display using two power supplies

Voltage Output

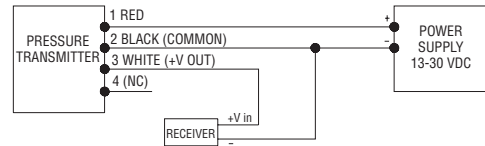

Fig. F: Voltage output connection

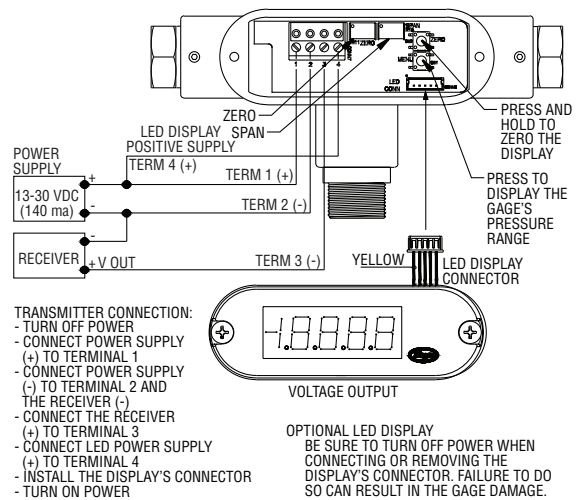

Fig. G: Voltage output with optional LED display

MULTIPLE RECEIVER INSTALLATION

An advantage of the standard 4-20 mA DC output signal provided by the Series 629 Differential Transmitter is that any number of receivers can be connected in series in the current loop. Thus, an A-701 digital readout, an analog panel meter, a chart recorder, process controlling equipment, or any combination of these devices can be operated simultaneously. It is necessary only that each be equipped with a standard 4-20 mA input and proper polarity of the input connections be observed when inserting the device into the current loop. If any of the receiving devices displays a negative or downscale reading this indicates that the signal input leads are reversed.

MAINTENANCE

Upon final installation of the Series 629 Differential Pressure Transmitter and the companion receiver, no routine maintenance is required. A periodic check of the system calibration is recommended. The Series 629 Differential Pressure Transmitter is not field serviceable and should be returned if repair is needed (field repair should not be attempted and may void warranty). Be sure to include a brief description of the problem plus any relevant application notes. Contact customer service to receive a return goods authorization number before shipping.

