



# OPTIMA 7

## USER MANUAL



Legal notices / Intellectual property rights comments

Original user manual

© 2021 by MRU

No part of this manual may be published in any form (print, photocopy, electronic media or any other publication form) without a written approval by the publisher.

All user trade marks and name mark descriptions, even those which are not marked as such, are properties of the respective owners.

Edition: 2021-04-19,V3.10.EN

**Table of content**

**1 Information for product and safety ..... 6**

1.1. Safety manual .....6

1.2. Safety precautions.....6

1.3. Ensure safety .....7

1.4. Important general information about the device.....7

1.5. User guideline for rechargeable batteries.....8

**2 Introduction ..... 9**

2.1. Intended use .....9

2.2. About us ..... 10

2.3. Packaging ..... 11

2.4. Return of hazardous materials ..... 11

2.5. Return of electronic equipment..... 11

**3 Description ..... 12**

3.1. Gas schematics diagram ..... 12

3.2. The Analyser ..... 13

3.3. The Condensate separator (water trap) ..... 14

3.4. Extraction probes..... 15

**4 Operating ..... 16**

4.1. Display ..... 16

4.2. Keypad..... 17

4.3. Menu structure ..... 18

**5 First usage ..... 19**

5.1. Preparatory steps ..... 19

5.2. Analyzer settings ..... 19

5.3. Setting measurement..... 20

5.4. Power-On protection ..... 22

5.5. Setting printer type and print out..... 22

5.6. Setting Bluetooth parameters..... 23

5.7. Setting date and time ..... 24

5.8. Configuring Measurement Programs ..... 24

5.9. Setting CO limit value ..... 25

5.10. Select fuel types and O2 reference ..... 25

    Adding fuels to fuel type selection..... 26

    Setting O<sub>2</sub> reference..... 26

5.11. Defining user fuels type ..... 27

5.12. Defining measurement window ..... 28

5.13. Configuring zoom window ..... 29

5.14. Changing measurement program names..... 29

**6 Preparing measurement..... 30**

6.1. Ensure power supply ..... 30

6.2.	Automatic Auto-off function.....	30
6.3.	Measuring with grid power supply / Battery charging.....	30
6.4.	Battery charge condition .....	30
6.5.	Operating temperature .....	31
6.6.	Controlling Condensate separator (water trap).....	31
6.7.	Connections and tightness .....	32
6.8.	Automatic zero-point setting.....	32
	Repeating the zeroing .....	32
<b>7</b>	<b>Performing measurement .....</b>	<b>33</b>
7.1.	Selecting the measuring program.....	33
7.2.	Core flow search .....	34
7.3.	Measured value display.....	35
7.4.	Non-continuous draft measurement .....	36
7.5.	Setting CO-Limit (without purging).....	37
7.6.	CO-purging.....	37
7.7.	CO/H2 and CO high (optional).....	38
7.8.	Performing Test program .....	38
7.9.	Performing Ambient CO Test.....	38
7.10.	Temporary buffer.....	40
	Store measured values in the buffer .....	40
	Overwrite measured values in buffer .....	41
7.11.	Storing measured values .....	41
7.12.	Printing measurement values.....	42
7.13.	Terminate measurement.....	43
7.14.	Last measurement values .....	43
7.15.	Pressure measurement .....	44
7.16.	Differential temperature measurement (optional) .....	45
<b>8</b>	<b>Data Storage .....</b>	<b>46</b>
8.1.	Organizing data storage .....	46
8.2.	Calling up information about data storage .....	46
8.3.	Site administration .....	47
	Create new site.....	47
	View sites.....	48
	Searching site.....	48
	Changing sites .....	49
	Deleting sites .....	50
8.4.	Data transfer using SD card.....	51
	Importing sites .....	51
	Exporting sites .....	53
	Exporting combustion measurements.....	53
	Exporting differential pressure measurements.....	54

8.5.	Measurement in Data storage.....	54
	Viewing measurements.....	54
	Deleting measurements.....	55
	Transferring measurements to SD-Card (Option).....	56
<b>9</b>	<b>Extras / Adjustment .....</b>	<b>57</b>
9.1.	Service calibration menu .....	57
9.2.	Default settings .....	58
9.3.	Service values.....	59
9.4.	Performing leak test.....	59
9.5.	Contents SD card.....	61
9.6.	Contents Analyzer information .....	61
<b>10</b>	<b>Maintenance and care .....</b>	<b>62</b>
10.1.	Maintenance.....	62
10.2.	Service messages.....	62
<b>11</b>	<b>Appendix.....</b>	<b>63</b>
11.1.	Technical data.....	63
11.2.	Analysis and calculations.....	67
11.3.	Text input .....	69
11.4.	Asking user for decision.....	69
11.5.	Firmware update.....	70
	Install the new software version in the analyser .....	70
	Performing and checking the update .....	70
	In case of error .....	71
11.6.	Using the USB Port .....	72
11.7.	Troubleshooting .....	72
	Troubleshooting the analyser.....	72
	Troubleshooting condensate separator.....	74
11.8.	Further options.....	74
	Prefilter for high dust concentrations.....	74
<b>12</b>	<b>Declaration of conformity .....</b>	<b>75</b>

# 1 Information for product and safety

## 1.1. Safety manual

All general information and safety precautions of MRU products are listed in the supplied separate safety manual.

Therefore, this manual must be read and observed before the first use of the instrument.

Instrument-specific safety and warning requirements in this manual are prefixed before dangerous actions.

## 1.2. Safety precautions

The used categories of safety precautions are here explained once more.



### **⚠ DANGER**

Identifies an immediate, impending hazard that, if ignored, will result in severe bodily injuries or death.



### **⚠ WARNING**

Identifies an immediate, impending hazard that, if ignored, may result in severe bodily injuries, material damage or death.



### **⚠ CAUTION**

Identifies a possibly dangerous situation that, if ignored, may result in minor injuries.



### **ATTENTION**

Identifies a possibly harmful situation that, if ignored, may result in damages to the device or its surroundings.



### **NOTE**

Identifies user tips and other especially important information.

The explanation of safety notices:



### **⚠ CAUTION**

**HOT – danger of burns and fire hazards from gas extraction probe.**

Physical harm and property damage can be caused.

▶ Cool down the probe tube.

### 1.3. **Ensure safety**

- ▶ Please read the user manual completely before the first use.
- ▶ Only use the analyser for the intended use and within the parameters specified in the technical data.
- ▶ Do not use any violence.
- ▶ Avoid falls.
- ▶ Do not put the analyser into use, if the housing, power supply unit or supply leads are damaged.
- ▶ Do not store the analyser together with solvents. Do not use desiccants.
- ▶ Only carry out maintenance and service work on this analyser as described in the User Manual. Observe the prescribed action steps.
- ▶ Operate the analyser only in closed, dry rooms and protect it from rain and moisture.
- ▶ When operating the analyser on mains power, operate it only with the mains adapter supplied.
- ▶ Do not use the metal tube of the gas sampling probe or other metallic parts / accessories as electrical conductors.
- ▶ The analyser must not be located in the immediate vicinity of open fire or great heat.
- ▶ The specified temperature range of the gas sampling probe must not be exceeded, otherwise the probe tube and temperature sensor will be destroyed.

### 1.4. **Important general information about the device**

- The analyser is not suitable for long term (continuous) measurements (this is a spot analyser).
- Before using the analyser verify the condition of the various parts of the analyser, such as the probe, the ambient air conditions, the condensate separator, star filter and the connectors for damage and/or blockages.
- When starting the analyser up it will take between 1 – 3 minutes to set to zero depending on the condition of the sensors and ambient conditions. (Zeroing).
- The minimum zeroing time of the analyser to achieve correct measurement values can be expected by 1.5 minutes!
- Exposure to acids; aggressive gases such as Sulphur; vapours such as thinners, gasoline, alcohol and paint, etc. can damage, reduce the life of, or destroy the sensors.
- The life of the sensors depends on how they are used, maintained and treated. Typical average life expectations are: O<sub>2</sub> - 2 years; CO - 2 - 3 years and NO - 3 years.

- The battery life is at least 500 charge-discharge cycles. With increasing number of charging cycles the battery capacity (indicated in operating hours) is reduced.

### 1.5. User guideline for rechargeable batteries

#### NOTE



The rechargeable batterie is installed inside the analyser and is not accessible to the end customer. However, the following instructions must generally be observed when handling lithium-ion rechargeable batteries.

- This rechargeable battery can only be used in this analyser.
- Do not throw the rechargeable battery into a fire, charge it at high temperatures and store it in a hot environment.
- Do not deform, short-circuit or modify the rechargeable battery.
- The rechargeable battery must not be used in or under water.
- Do not expose the rechargeable battery to strong mechanical forces and do not throw it.
- Do not cut or squeeze the connecting cables of the rechargeable battery.
- Do not connect the (+) contact to the (-) contact or metal.
- Non-observance of the above guidelines can cause heat, fire and explosions

## 2 Introduction

- This manual enables you to understand and safely operate this MRU Analyzer.
- Please read this manual with great vigilance and get familiar with the product before using it.
- This analyser may only be operated by competent personnel and for its intended use.
- Please pay special attention to all safety directions and warnings to prevent personal injuries and damaging of the product.
- We can't be held responsible for any injuries and/or damages that occur by not following the instructions in this manual.
- Always keep the manual near you when working with the analyser, to be able to read instructions as needed. Please ensure to hand over all documents to when handing the analyser over to others.

### 2.1. Intended use

The Analyzer analyser is intended for short-term measurement in the context of emission control measurements and adjustments at small furnaces. The analyser measures the measurements provided by VDI4206 and EN50379 metrics and stores them for further processing.

The analyser is specifically not intended as a safety device or personal protective equipment.

The analyser should not be used as a warning device to warn people against the presence of harmful gases.

The analyser must be used according to instructions for the intended use.

Our analysers are checked according to the following regulations:

**VDE 0411 (EN61010)** and **DIN VDE 0701** before they leave the MRU GmbH factory.

MRU technical products are designed and manufactured according to **DIN 31000/ VDE 1000** and **UVV = VBG 4** of the professional guilds for fine mechanics and electrical engineering.

MRU GmbH assures that the analyser complies to the essential requirements of the legal regulations of the member states of the electro-magnetic compatibility (**89/336/EWG**)



#### **▲ WARNING**

##### **Risk from manipulations to the measuring device**

Operational safety hazard

- ▶ Modifications or changes to the measuring device are not allowed.

## 2.2. **About us**

The analyser

(Founded in 1984), a medium sized company that specializes in developing, producing and marketing high quality emission monitoring analysers.

MRU GmbH produces a wide range of instruments, from standard analysers up to tailor made industrial analysers.



Plant 1: Sales, Service, R&D



### 2.3. **Packaging**

Save the original carton and packing materials to prevent damage in transit in case you need to return the unit to the factory.

### 2.4. **Return of hazardous materials**

Waste Disposal/Returns/Warranty - MRU GmbH is required to accept the return of hazardous waste such as electro-chemical sensors that cannot be disposed of locally.

Hazardous waste must be returned to MRU prepaid.

### 2.5. **Return of electronic equipment**

MRU GmbH is required to accept the return, for proper disposal, of all analysers delivered after 13th of August 2005. Analysers must be returned to MRU prepaid.

### 3 Description

The main task of the analyser is to assist with precision control and adjustment measurements of gas, oil and wood fired furnaces. Available options for this and other analysers can be found on the MRU Homepage or speak to a member of our sales team.

#### 3.1. Gas schematics diagram

In combination with the extraction probe (inserted in the stack) the internal gas pump of the **OPTIMA7** analyser extracts a portion of the flue gas and analyses it using electro-chemical sensors.

The thermo-element in the probe tube measures the flue gas temperature and due to the construction of the probe pressure (draft) can be measured as well.

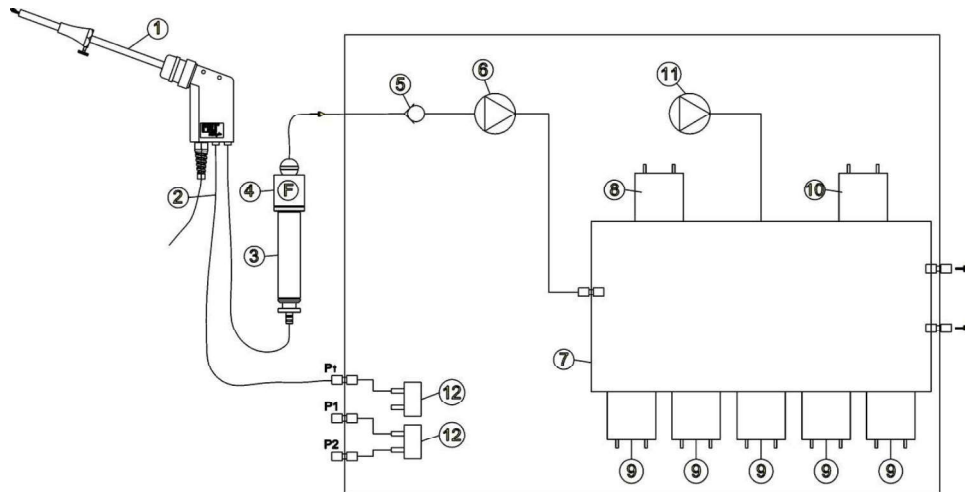

Position	Description
1	Sampling probe
2	Triple hose
3	Condensate separator
4	Star filter
5	Non return valve
6	Gas pump
7	Sensor chamber
8	O <sub>2</sub> -Sensor
9	Further electrochemical sensors optional*
10	CO <sub>2</sub> NDIR *
11	CO Purge pump * / not available with CO <sub>2</sub> -NDIR
12	Pressure sensor *
	*optional

### 3.2. The Analyser

The compact analyser is made from a fibre re-enforced plastic material with all measurement related connections at the bottom of the analyser.



Position	Description
1	Display
2	Key pad
3	Temperature connector T2
4	Temperature connector T1
5	Pressure connector P1
6	Pressure connector P2
7	Gas outlet
8	IR-Interface
9	USB-port and charging port
10	SD-card reader
11	Fixing magnets
12	Analyzer feet
13	Handle strip
14	Gas outlet
15	Pressure connector P3
16	Connector AUX



#### ATTENTION

##### Gas outlet:

During measurement the gas outlet must not be covered

### 3.3. The Condensate separator (water trap)

**• CAUTION**



**Condensate is acidic**

The condensate from the container can be slight acidic and can cause chemical burn.

- ▶ Immediately clean with plenty of water once you have encountered acid

During the measurement accumulating condensate is collected in the condensate separator

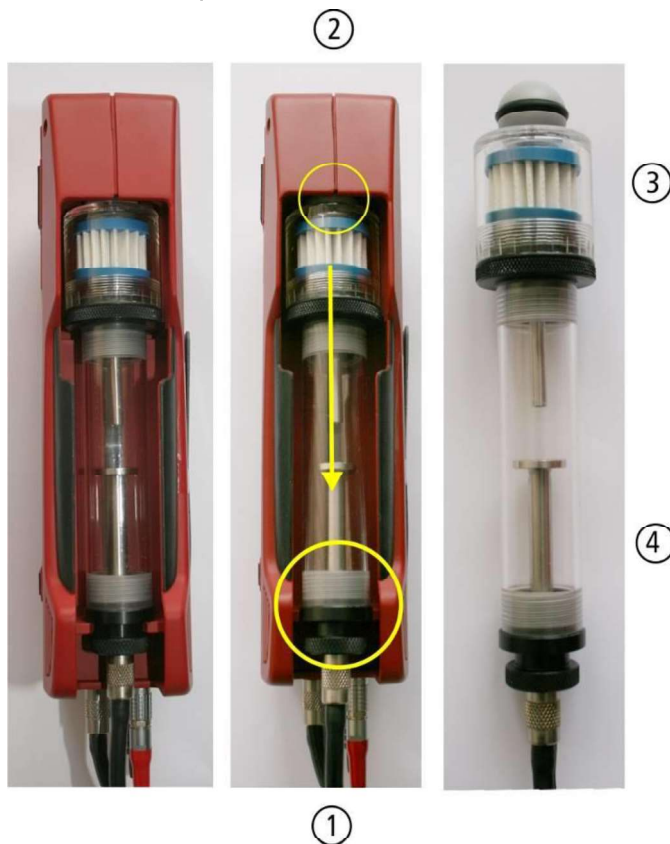

Remove the condensate separator by pulling it towards you (1) out of the groove of the OPTIMA 7 housing, then pull it downwards (2). Condensate vessel and plugs are screwed together. To change the filter and dry and clean the condensate separator this can be easily disassembled and screwed together again. After cleaning, a leak test must be carried out.

☞ See also chapter 9.4 Performing leak test, Page 59.

In the condensate separator of the OPTIMA7 an exhaust gas filter is attached. This filters out the first coarse dirt. This pocket star filter is washable and can be used 4-5 times afterwards. Frequent measurements result in a high degree of contamination which requires regular replacement of this filter.

### 3.4. Extraction probes

The analyser is available with either a probe with fixed probe tube or with exchangeable probe tubes. A complete list of available probe options can be found in our effective price list.

Here 2 variants are shown as examples:

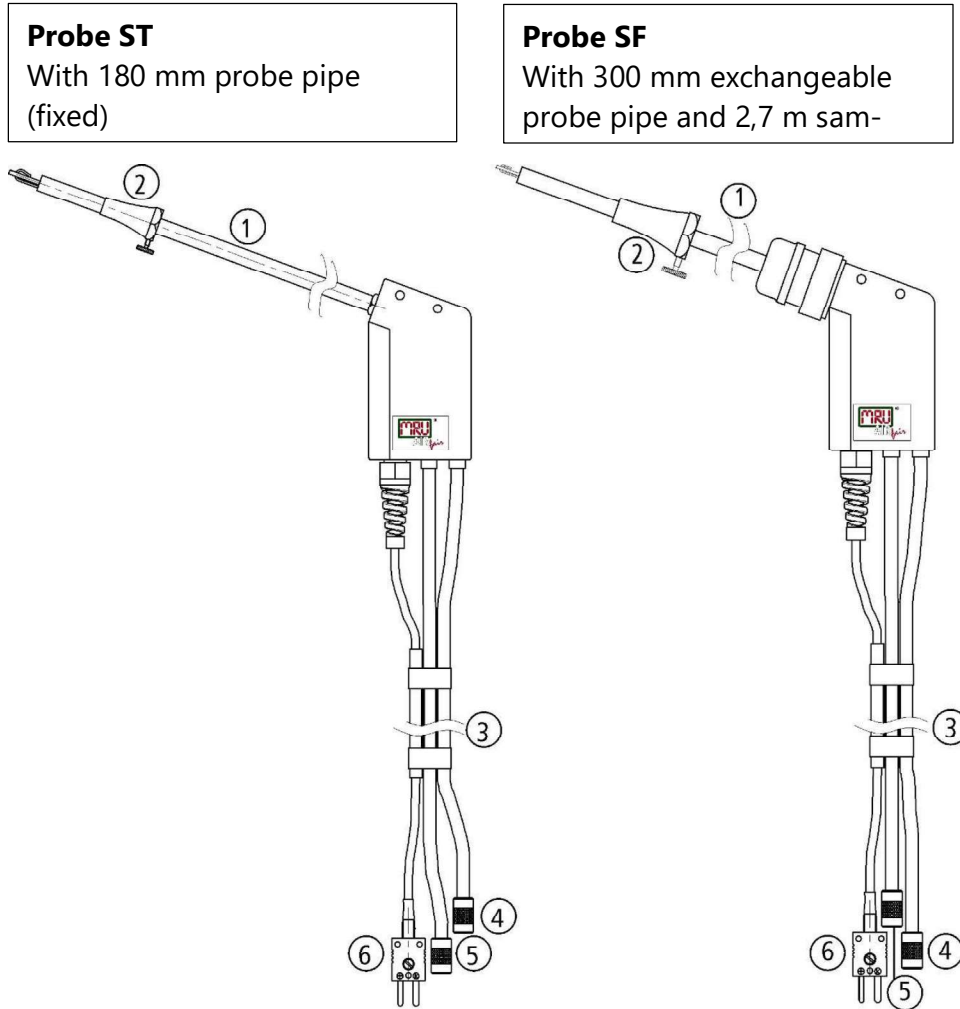

1	Probe tube
2	Probe cone (high grade steel)
3	Triple hose (NBR or Viton)
4	Connector for sample gas measurement
5	Connector for draft measurement
6	Connector for temperature measurement

## 4 Operating

### 4.1.Display



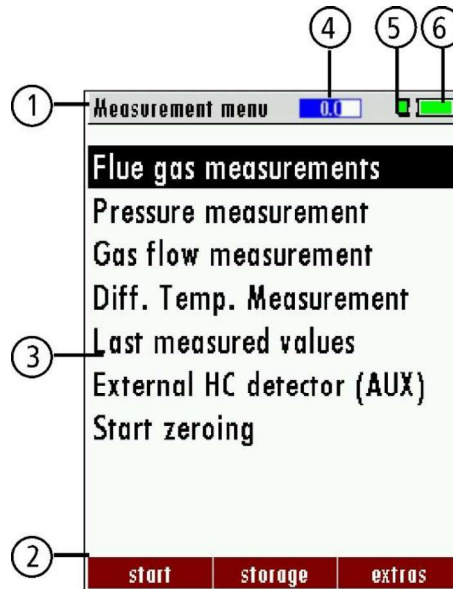



All information required to operate the analyser is displayed as shown below.



Position	Description
1	Menu bar
2	Function key bar
3	Display panel 1. Menu 2. Measurement value
4	Zeroing active
5	SD-Card in the slot  1. Indication green Read- and write access  Indication yellow only Read access (SD-Card write protected)
6	Battery charge condition

## 4.2. Keypad

Description and function of the keys:

<p><b>ON/OFF</b></p> 	<p>Press to start the analyser without delay. The power off function will be delayed to protect the sensors. If there is not enough ambient air the analyser will recommend the purging of the sensors.</p>
<p><b>Function Keys</b></p> 	<p>Activates the functions seen on the display (2 function key bar).</p>
<p><b>Menu Key</b></p> 	<p>Will show all available functions in the window that is currently in use – also those which have an individual key on the key pad like the printer and the three function keys.</p>
<p><b>ESC</b></p> 	<p>Abort or return to the menu above</p>
<p><b>Arrow Keys</b></p> 	<p>Jump in between lines, change values</p>
<p><b>OK</b></p> 	<p>Confirmation key, select a marked menu point</p>
<p><b>Printer</b></p> 	<p>Activates the printer function in the measurement and service window</p>

### 4.3. Menu structure

The analyser organizes all available actions in three main menus:

- **Menu Measurement**  
All available measurement options will be displayed and can be selected here.
- **Menu Storage**  
All available storage options will be displayed and can be selected here.
- **Menu Extra**  
All other actions are available here to manage and customize the device.

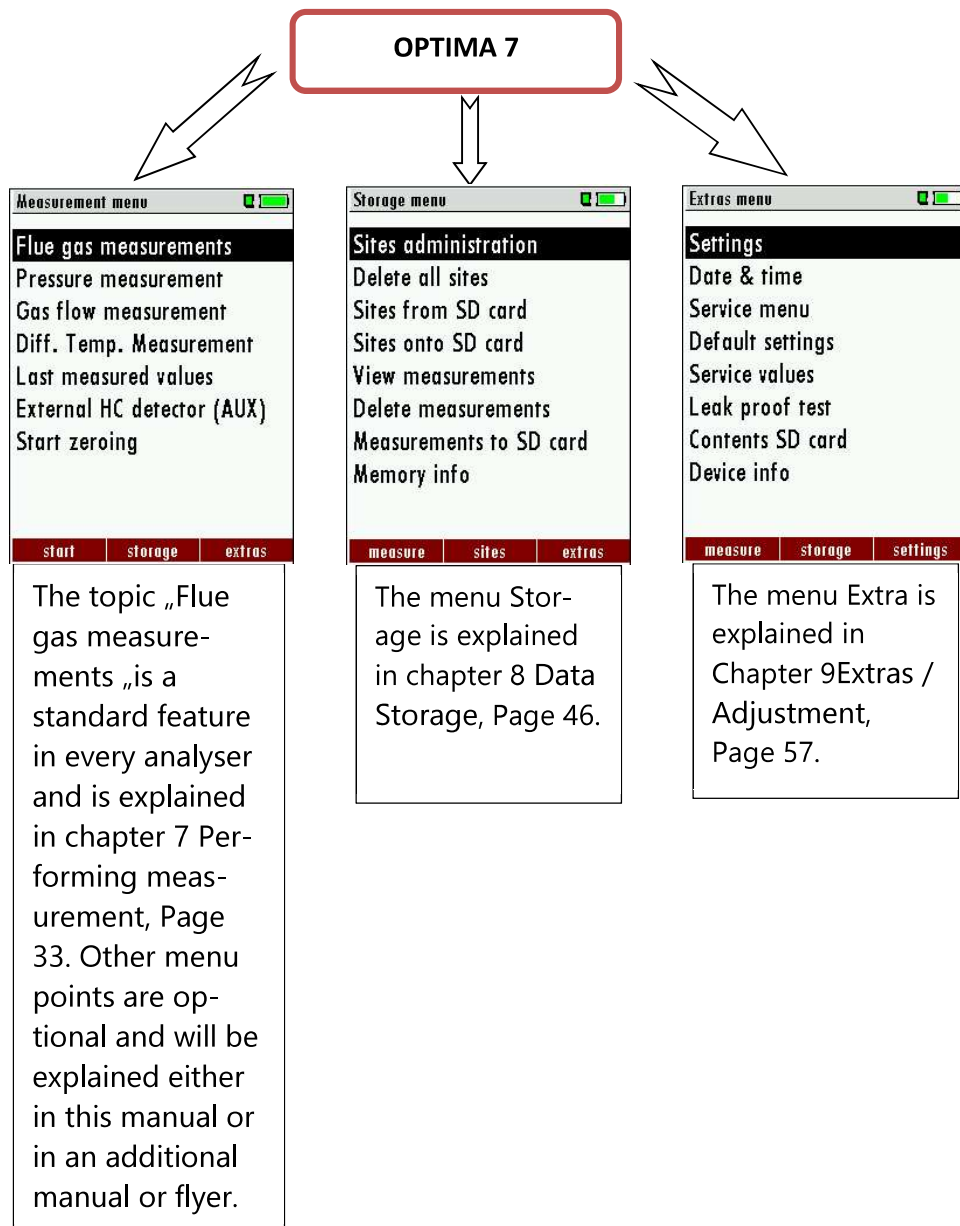

You can jump in between the 3 main menus with the 3 function keys (according to the displayed name on the screen).

## 5 First usage

After the analyser has been inspected and is ready for start-up it can be switched on and personalized settings can be entered. These settings can be changed at any time.

### 5.1. Preparatory steps

- ▶ Unpack the analyser.
- ▶ Read the User Manual completely.
- ▶ The analyser leaves the factory assembled and ready for use.  
Nevertheless, check the device for completeness and integrity.
- ▶ Charge the battery of the analyser for about 8 hours.
- ▶ Check date and time. Modify if needed.

### 5.2. Analyzer settings

The “Settings” menu allows configuring some instrument specific parameters.

In the main menu “EXTRAS “= “F3 key” - scroll down to “Settings “then press the “OK “key. By selecting a line, the parameter value can be changed by the arrow keys.

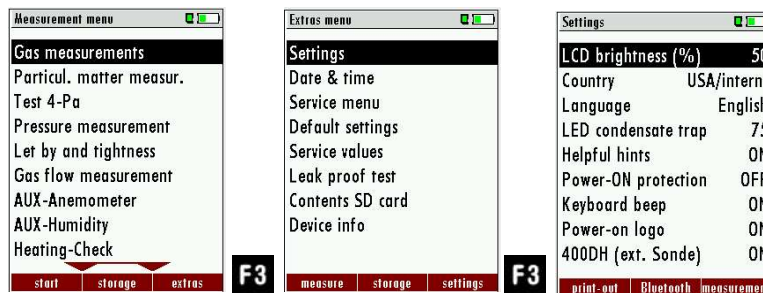

Setting	Range	Description
LCD brightness	5 – 100 %	Display-brightness, depending on temperature and also on the personal judgement of the user, at 20°C a value of ca. 50% is normal
Language	option	Select device languages
Country	option	Enables some country specific parameters like fuel types, calculated values etc.
LED condensate trap	0 ... 150	Change the brightness of the condensate separator LED
Helping hints	ON / OFF	Helpful hints activated or deactivated (explanation below)
Switch-ON protection	ON / OFF	If activated and if ON key is pressed (possibly inadvertently), then the message „3 seconds OK key press “is displayed
Keyboard beeper	ON / OFF	Keyboard beeper activated or deactivated
Power-on logo	ON / OFF	Logo will be show during power-ON of the analyser

### 5.3. Setting measurement

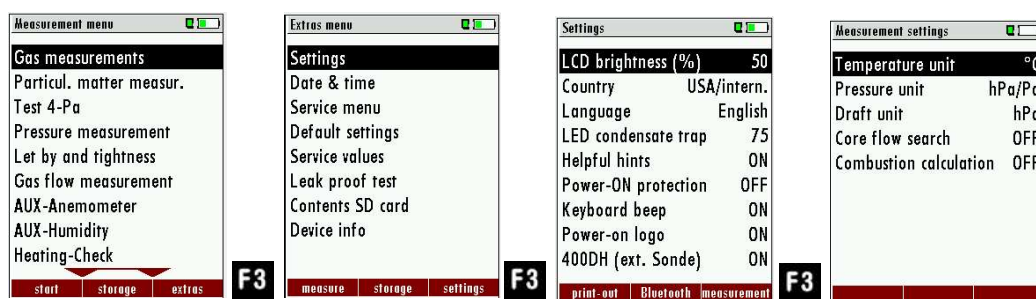

- ▶ Press F3.
  - ⇒ The Extras menu appears.
- ▶ Press F3.
  - ⇒ The menu Settings appears.
- ▶ Press F3.
  - ⇒ The menu Measurement settings appears.

In the "Measurement settings" menu you can make for example the following adjustments:

Temperature Unit	°C, °F	Change the unit for temperature in all screens
Pressure Unit	Pa, hPa/Pa, hPa, kPa/Pa, kPa, mbar, mmH2O, cmH2O, inH2O, mmHg, inHg, PSI,	Change the unit for pressure in all screens. The meaning of hPa/Pa and kPa/Pa is that the instrument performs a dynamic change of unit depending on the absolute value of pressure.
Draft Unit	Pa, hPa/Pa, hPa, kPa/Pa, kPa, mbar, mmH2O, cmH2O, inH2O, mmHg, inHg, PSI,	Change the unit for pressure in all screens. The meaning of hPa/Pa and kPa/Pa is that the instrument performs a dynamic change of unit depending on the absolute value of pressure.
Core flow search	ON / OFF	Core flow search before start of each flue gas measurement: activated or deactivated
Combustion calculation	ON / OFF	<p>If the combustion calculation is switched off following items will be changed:</p> <ul style="list-style-type: none"> <li>- no fuel types, respectively always "Sample Gas"</li> <li>- no measuring values losses, ETA, ETAcond, Dev. point</li> <li>- no measuring value CO<sub>2</sub>, except it will be measured</li> <li>- no measuring values CO/NO/,,, in [mg/kWh]/[mg/MJ]</li> <li>- no fuel type will be shown on the menu bar and print-out</li> </ul>

Explanation for "Helping hints":

Some helpful hints which are very useful for an inexperienced user but are not needed by experienced users, can be activated or deactivated. The following hints will be affected

- "Zeroing finished, Sensors are ready. Analyzer ready for measurement."
- "Reminder! Charge batteries at regular intervals!"
- "Measurement stopped/started."

**5.4. Power-On protection**

If activated and if ON key is pressed (possibly inadvertently), then the message: „Power-On protection is activated! Press key OK for 3 seconds 2" is displayed.

**5.5. Setting printer type and print out**

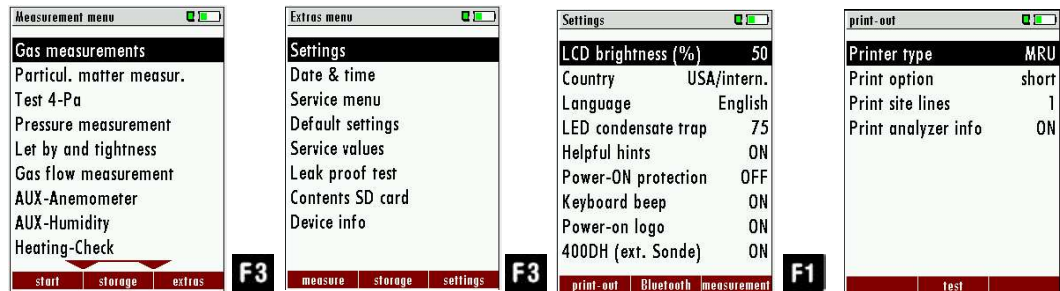

- ▶ Press F3.
  - ⇒ The Extras menu appears.
- ▶ Press F3.
  - ⇒ The menu Settings appears.
- ▶ Press F1.
  - ⇒ The menu print-out appears.

In the menu "print-out" menu you can make for example the following adjustments:

Printer type	Select printer type MRU / HP
Print logo ON/OFF	Print logo
Print option SHORT/LONG	SHORT: Print-out without area for signature and site information
Print site lines 0 ... 9	Line 1 (Site no.) is necessary
Print device info	To measuring print out can be shorter designed, while the device info will be left out. In some print outs (adjustment, service ...) the info will be printed forever.

### 5.6. Setting Bluetooth parameters

Depending on the equipment, the analyser can be used to exchange measurement data with external devices via Bluetooth:

- With MRU4u (App for Android and iOS smartphones)
- With MRU4Win
- With MRU Bluetooth printer
- With a large-scale module available as an accessory (suitable for training centres or laboratories).

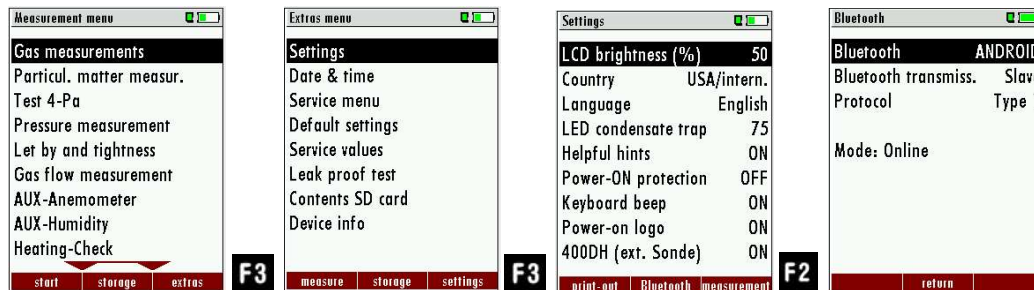

Depending on the software version of the analyser and the technical specification of the Bluetooth interface, settings for data transmission may be required. Please check in the following menu:

- ▶ Press F3.
  - ⇒ The Extras menu appears.
- ▶ Press F3.
  - ⇒ The menu Settings appears.
- ▶ Press F2.
  - ⇒ The menu Bluetooth appears.

If the settings window appears as shown above, please select whether you are connected to an Android or iOS smartphone. You realise a connection to the Bluetooth printer or to MRU4Win with the setting "ANDROID".

If "DUAL MODE (ANDROID/IOS)" appears in the settings window instead of the selection ANDROID and iOS, the Bluetooth module supports all applications without further settings.

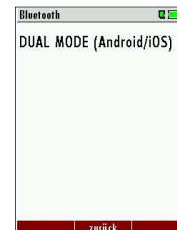

## 5.7. Setting date and time

The analyser has an automatic changeover from summer to winter time. If the built-in rechargeable battery is completely discharged, a new setting of these values is required

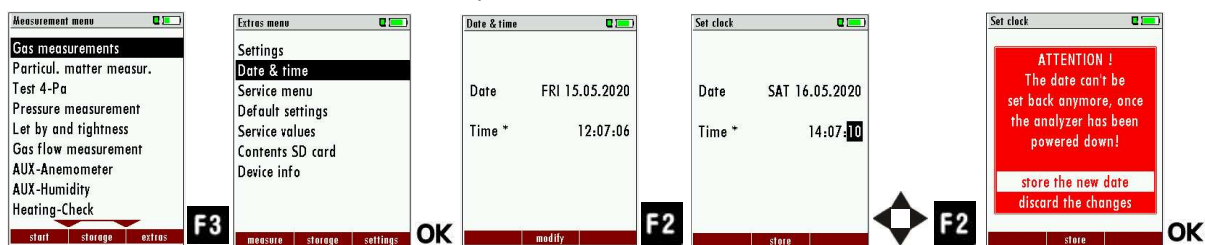

- ▶ Press F3.
  - ⇒ The Extra menu appears.
- ▶ Select Date & time.
- ▶ Press OK.
  - ⇒ The menu Date & time appears.
- ▶ Press F2.
  - ⇒ The menu Set clock appears.
- ▶ Set the desired date.
- ▶ Set the desired time.
- ▶ Press F2.
  - ⇒ A message appears.
- ▶ Select „store the new date“ or „discard the changes“.
- ▶ Press OK.
  - ⇒ The changes are stored or discarded.

## 5.8. Configuring Measurement Programs

(Flue gas measurements) Select one of the 6 configurable measurement programs.

For each of the programs the following parameters can be configured:

1. CO ppm limit: adjustable value for the CO sensor protection. If the CO value in the flue gas is higher than the adjusted value in the analyser, the purge pump will be activated and the sensor will be protected against high CO concentrations. (Optional)
2. Selectable fuel types: choose and select from the available fuel type list
3. Measurement windows: configuration of what and where will be displayed in the 3 measurement value windows.
4. Zoom – window: select what will be displayed in the zoom - window
5. Program name
- 6.

The following program is pre-configured:

“Test Program” indented for use at instrument maintenance and calibration.

### 5.9. Setting CO limit value

High CO concentrations in the gas stream can shorten the life span of your CO sensor. The analyser can warn the user if the analyser exceeds a pre-defined CO limit.

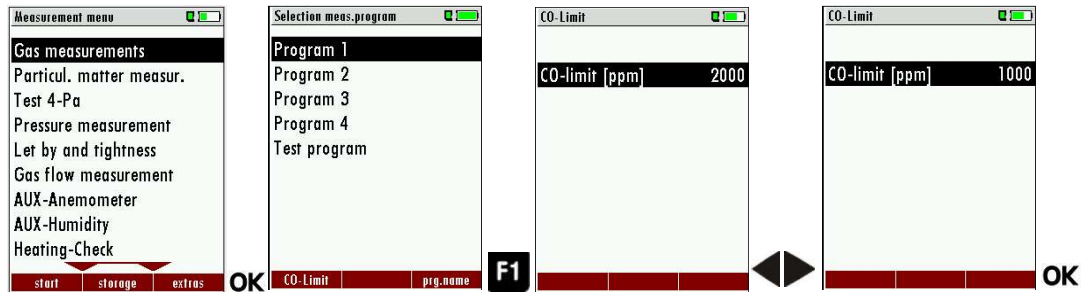

- ▶ Select Gas measurements.
- ▶ Press OK.
  - ⇒ The menu Selection meas. program appears.
- ▶ Select the desired measuring program from which the CO limit value is to be set
- ▶ Press F1.
  - ⇒ The menu CO-Limit appears.
- ▶ Set the desired CO-limit [ppm].
- ▶ Press OK
  - ⇒ The desired CO-limit [ppm] is stored.

### 5.10. Select fuel types and O2 reference

**NOTE**



Note that you can only set the fuel type selection and O2 reference if the combustion calculation has been switched on.

☞ See also Chapter 5.3 Setting measurement, Page 20.

Whenever a measuring program for flue gas measurement is called, a fuel can be selected from a list. Which fuel is available can be selected from a maximum fuel type list.

### Adding fuels to fuel type selection

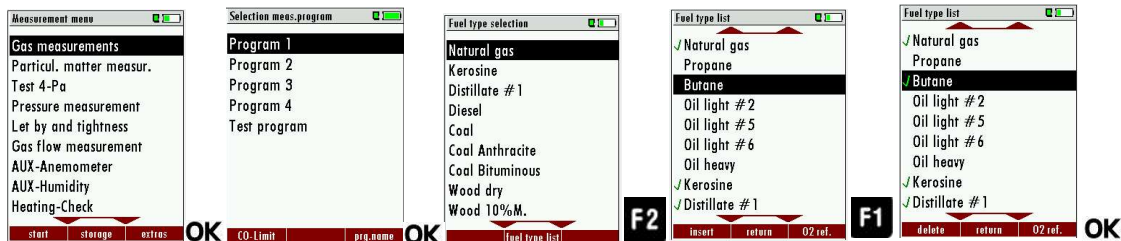

- ▶ Select Gas measurements.
- ▶ Press OK.
  - ⇒ The menu Selection meas. program appears.
- ▶ Press OK
  - ⇒ The menu Fuel type selection appears.
- ▶ Press F2.
  - ⇒ The menu Fuel type list appears.
- ▶ Select the fuel which should be added to the menu Fuel type selection.
- ▶ Press F1.
  - ⇒ The selected fuel is marked with a check mark
- ▶ Select other fuels if necessary.
- ▶ Press OK.
  - ⇒ The selected fuels are displayed in the menu Fuel type selection.

### Setting O<sub>2</sub> reference

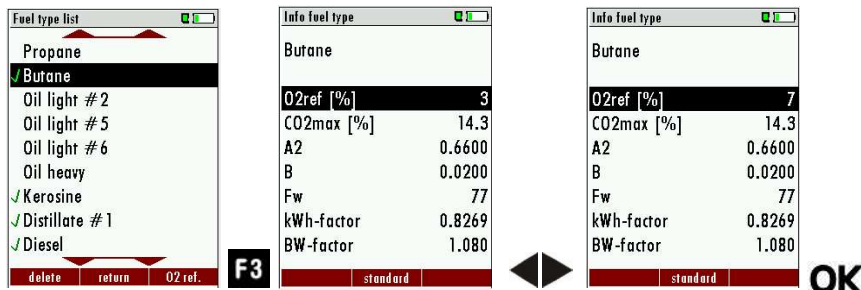

- ▶ Go to the menu Fuel type selection
  - ☞ See also Chapter Adding fuels to fuel type selection, Page 26
- ▶ Select the desired fuel.
- ▶ Press F3.
  - ⇒ The menu fuel type appears.
- ▶ Set the desired O<sub>2</sub> reference.
- ▶ Press OK.
  - ⇒ The set O<sub>2</sub> reference is saved.

5.11. Defining user fuels type

**NOTE**



Note that you can only set the fuel type selection and O2 reference if the combustion calculation has been switched on.

☞ See also Chapter 5.3 Setting measurement, Page 20.

You can define four fuels to your individual needs. You can define the name and the fuel parameters. Like the other fuels, you can add user fuels to the menu Fuel type selection.

**NOTE**



The last 4 fuels in the menu Fuel type list are the user fuels. The user fuels are indicated in the menu Fuel Type list in green colour.

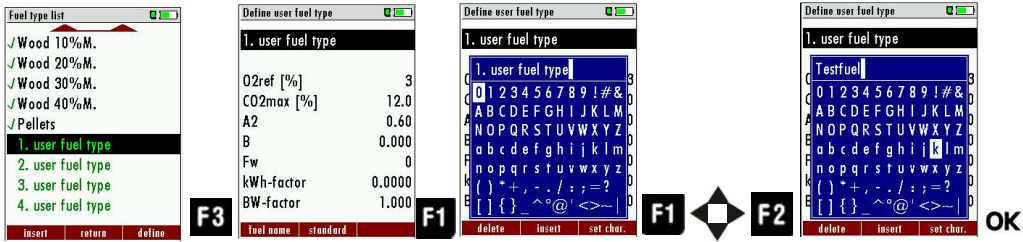

► Go to the menu Fuel type list.

☞ See also Chapter Adding fuels to fuel type selection, Page 26.

► Select the user fuel you want to define.

► Press F3.

⇒ The menu Define user fuel type appears.

► Press F1.

⇒ A window appears.

► Change the name of the user fuel to your needs

► Press OK

⇒ The changed name is displayed in the menu Define user fuel type.

⇒ After you have changed the name of the user fuel, you can define the fuel parameters.

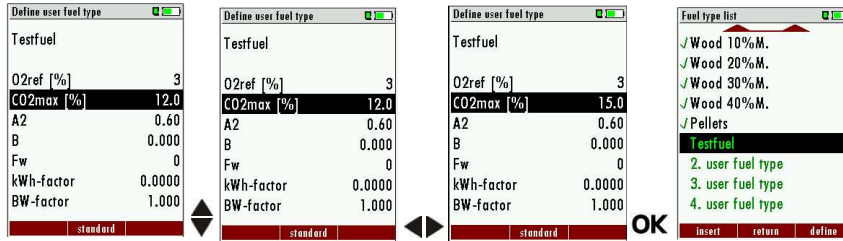

- ▶ Select the desired fuel parameter.
- ▶ Change the desired fuel parameter.
- ▶ Press OK.
  - ⇒ The defined user fuel appears in the menu Fuel type list.
  - ⇒ You can add the defined user fuel to the menu Fuel type selection.
  - ☞ See also Chapter Adding fuels to fuel type selection, Page 26

### 5.12. Defining measurement window



- ▶ Start a measuring program.
  - In this example Program 1, Natural gas.
- ▶ Select one of three measurement windows.
- ▶ Press the Menu Key.
  - ⇒ A selection list appears.
- ▶ Select Define measuring window.
  - ▶ Press OK
    - ⇒ The measurement window appears.
- ▶ Select the desired measured value that you want to change.
- ▶ Press the Menu Key.
  - ⇒ A selection list appears.
- ▶ Select Save measuring window.
  - ▶ Press OK.
    - ⇒ The change is saved.

### 5.13. Configuring zoom window

Three zoom windows are available in each measuring program for the zoomed display of 2 measured values each. Which values are displayed zoomed is configurable.

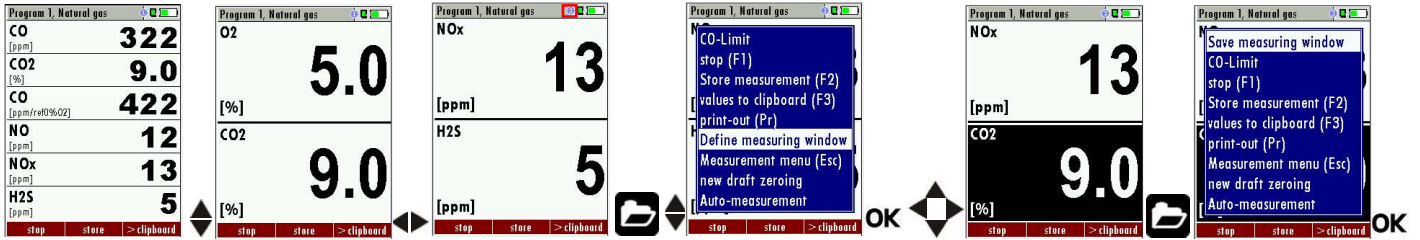

- ▶ Start a measuring program.  
In this example Programm1, Natural gas.
- ▶ Select the zoom function using the up / down arrow keys.
- ▶ Select one of three measurement windows.
- ▶ Press the menu key.
  - ⇒ A selection list appears.
- ▶ Select Define measuring window.
- ▶ Press OK.
- ▶ Select the desired measured value that you want to change.
- ▶ Press the Menu Key.
  - ⇒ A selection list appears.
- ▶ Select Save measuring window.
- ▶ Press OK
  - ⇒ The change is saved.

### 5.14. Changing measurement program names

In the menu Selection meas. program the name of the measurement program can be changed.

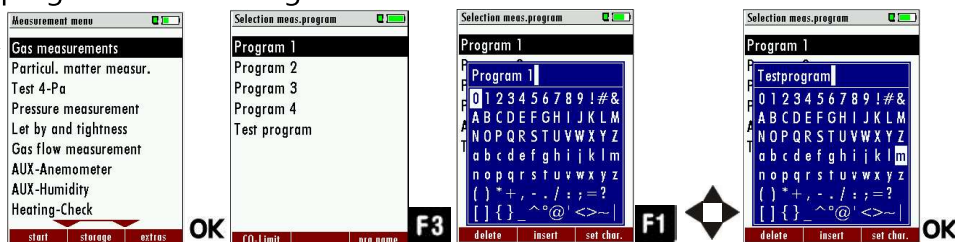

- ▶ Press OK
  - ⇒ The menu Selection meas. Program appears
- ▶ Press F3.
  - ⇒ A window appears.
- ▶ Change the name of the measurement program to your needs
- ▶ Press OK.
  - ⇒ The changed name is displayed in the menu Selection meas. program

## 6 Preparing measurement

### 6.1. Ensure power supply

The analyser can be used with:

- with the internal MRU battery (provided)
- with the MRU battery charger (provided)

External equipment may only be connected while the analyser is switched off!



### 6.2. Automatic Auto-off function

The instrument is automatically switched off after 60 minutes. During a measurement or a battery charging cycle the auto off is deactivated.

### 6.3. Measuring with grid power supply / Battery charging

Whenever you connect the analyser with external battery charger (90...260 V / 50/ 60Hz) the battery will be charged. Once the battery is fully charged the analyser will switch to trickle charge mode.

At the moment, if the battery is fully charged and the trickle charge mode begins, an acoustic feedback will be played.

### 6.4. Battery charge condition

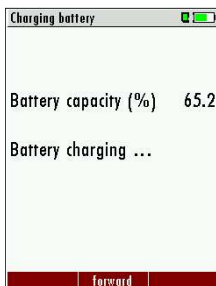

The battery symbol in the top right corner displays the current battery charge condition.

**Approximately 15 minutes** (depending on the analyser configuration) before the battery is drained, the battery symbol will start to blink red (about once per second).

When the battery is almost drained and the analyser is not connected to the battery charger within one minute, then the analyser will switch off automatically to prevent deep discharge of the battery.

## 6.5. Operating temperature

If the analyser has been stored at low temperatures, it will require some time to equilibrate to the ambient temperature before being switched on. If it does not equilibrate, condensation will occur inside the analyser! If the temperature is out of its operation range you will see the following messages on the display: "Analyzer too hot" or "Analyzer too cold" Once one of these messages appears you will not be able to use the analyser, it will give an acoustic signal until it has reached the specified operation temperature between +5°C and +45°C

☞ See also Chapter 11.1 Technical data, Page 63.



### ATTENTION

Once one of these messages appears you will not be able to use the analyser, it will give an acoustic signal until it has reached the specified operation temperature between +5°C and +45°C

## 6.6. Controlling Condensate separator (water trap)



### ⚠ CAUTION

#### Acid from the condensate

Acid burns may result from weakly acidic liquids from the condensate.

- ▶ If you come into contact with acid, wash the area immediately using a lot of water.

- ▶ Control the condensate separator before and after each measurement
- ▶ Check that the condensate separator is empty.
- ▶ Check the star filter.
  - ⇒ Star filter white = ready for use
  - ⇒ Star filter dark = renew

When switching off, a warning message is displayed:

### 6.7. Connections and tightness

Check all plug connections for correct fitting.

Check all hoses, hose connections, condensate containers (from the probe tip to the gas connection on the analyser) for tightness.

The analyser has a built-in automatic test to check the tightness of the gas paths.

☞ See also Chapter 9.4 Performing leak test, Page 59.

### 6.8. Automatic zero-point setting



**NOTE**

The probe must not be in the exhaust gas during the zeroing.

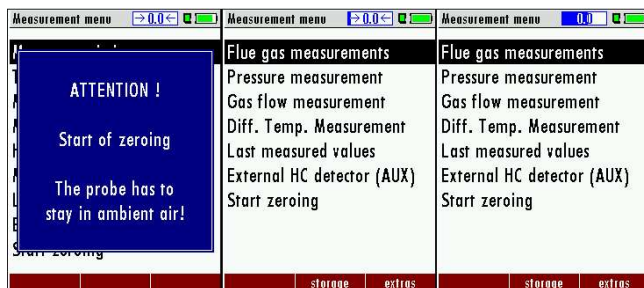

► Switch on the analyser.

- ⇒ The analyser autonomously carries out a zero point measurement.
- ⇒ During zeroing, the -> 0.0 <- symbol flashes in the upper right corner of the display.
- ⇒ After zeroing is complete, the analyser is ready for measurement.
- ⇒ If sensors are faulty, the error is identified during zeroing and an error message is displayed.

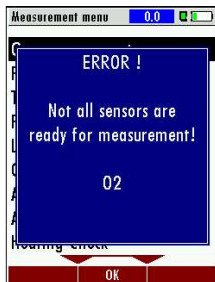

### Repeating the zeroing

The zeroing can be repeated at any time as long as the probe is not inside the stack.

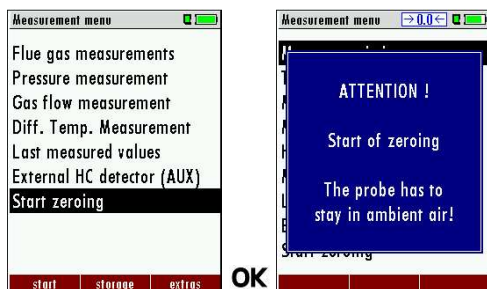

## 7 Performing measurement

In the basic configuration, each analyser has the complete functionality you need for gas measurement.

The process of gas measurement is described below.

The description of other optionally available measuring programs can be found in the appendix or on separate supplementary sheets.

### 7.1. Selecting the measuring program

#### DANGER

##### **Rick due to toxic gases**



There is a risk of poisoning.

Noxious gases are sucked in by the measuring device and released into the ambient air.

- ▶ Only use the measuring device in well ventilated spaces.

#### NOTE

##### **Wrong measuring results**



The extracted flue gas must be able to evacuate the analyser without obstruction.

- ▶ The exhaust outlet at the rear of the analyser may never be covered during a measurement, never operate the analyser in a transport case.

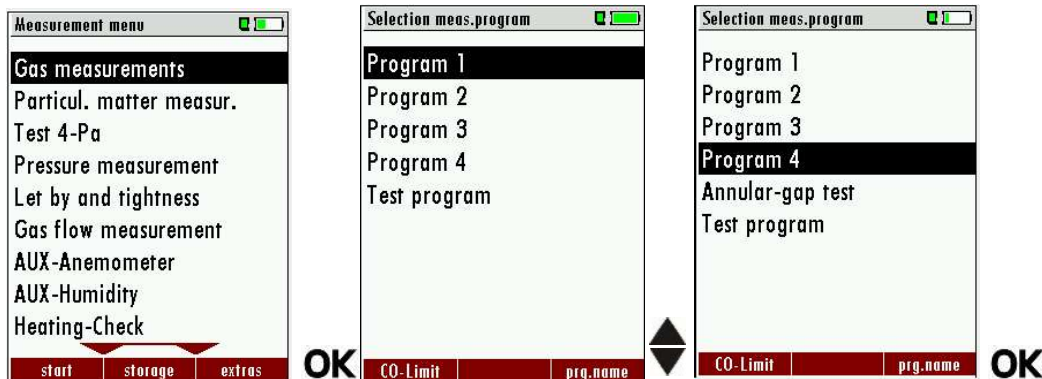

- ▶ Go to the Measurement menu.
- ▶ Press OK.
  - ⇒ The menu Selection meas. program appears.
- ▶ Select the desired measurement program.
- ▶ If necessary, change the CO limit.
  - ☞ See also Chapter 5.9 Setting CO limit value, Page 25.
- ▶ Change the measuring program name if necessary.
  - ☞ See also Chapter 5.14 Changing measurement program names, Page 29.
- ▶ Press OK.
  - ⇒ The menu Fuel type selection appears.
- ▶ Select the desired fuel.
- ▶ If necessary, add fuels from the fuel type list to the menu Fuel type selection.
  - ☞ See also Chapter Adding fuels to fuel type selection, Page 26.
- ▶ Press OK.
  - ⇒ The measurement is started.

**NOTE**

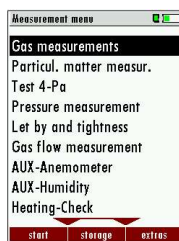

You can start a measurement with the previously set measurement parameters directly from the Measurement menu.

- ▶ Press F1.
- ⇒ The measurement is started.

**7.2. Core flow search**

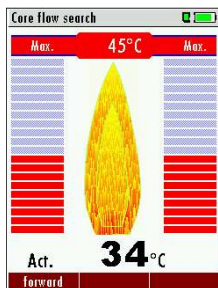

The core flow search will help you to find the optimal measurement point in the stack. The core flow can be identified by the maximum flue gas temperature. In high reaction time the analyser displays the trend of the flue gas temperature. Insert the probe pipe slowly into the stack and position your probe tube when you have reached the maximum flue gas temperature that is displayed

Before using the core flow search it must be switched-on:



Positioning the probe in the core flow:

Insert the probe pipe slowly into the stack and position your probe pipe when you have reached the maximum flue gas temperature that is displayed (see temperature maximum value on the display – in this case 45°C).

Maximum temperature has been reached when the arrows (left picture) disappear, max. (Right picture) appears in place of the arrow, and the beeper signal stops. Moving away from the max. Temperature will result in the bars moving away from the max. Temperature (1 bar is equivalent to 1°C). Once the right core flow has been achieved, the probe is fixed with the probe cone screw.

**7.3. Measured value display**

After the core flow search you will see the measurement values on the display.

Measurement values can be organized on three pages, each page displaying 6 measurement values.

The order of the display is operator settable.

There are direct measured values available such as Oxygen and Temperature as well as calculated values such as dew point, efficiency and CO<sub>2</sub>. You will also find the same measurement value in different calculated values such as CO in ppm or CO in mg/kWh.

Program 1	
O2	<b>3.8</b>
[%]	
CO	<b>22</b>
[ppm]	
NO	<b>12</b>
[ppm]	
NOx	<b>13</b>
[ppm]	
T-gas	<b>187.2</b>
[°C]	
T-air	<b>20.1</b>
[°C]	
stop	store > clipboard

Values that cannot be displayed are indicated with dashes. Possible reasons for value not being displayed are:

- Electro chemical sensor was detected as defective during zeroing.
- External temperature sensors are not connected.

The measurement value T-Gas is usually read at the connector "T-Gas/AUX" (depending on configuration) or if not available from the connector "T1".



There are three measurement windows available, with the arrow keys left and right moving between them. Zoom function, each with two values, is activated by moving the arrow keys up and down. Moving arrow keys left and right pages between the two zoom windows.

**7.4. Non-continuous draft measurement**

The analyser provides for a non-continuous draft measurement. The draft measurement is disabled when a maximum time after zeroing has elapsed or a significant change in temperature has been detected by the instrument. The maximum time is configured to 10 minutes. If the draft measurement is disabled it is displayed with "--.-". The draft measurement can be enabled again by zeroing the draft: F3 key "zero draft". To indicate that the draft measurement is not continuously available it is displayed in colour red.

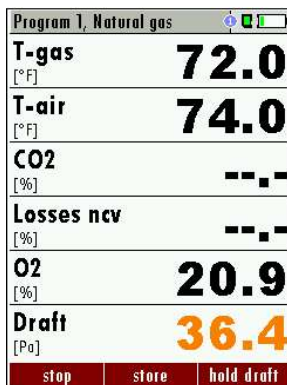

The user can freeze the draft data by means of the F3 key "hold draft". The frozen data is displayed in green. The unfreeze the measurement one has to exit the menu and enter again

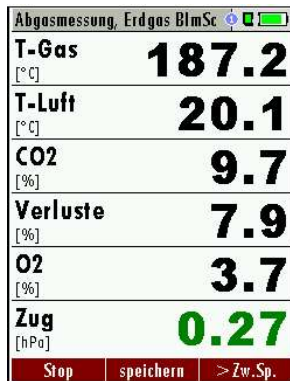

All other measurements are processed continuously independent of the draft measurement status.

### 7.5. Setting CO-Limit (without purging)



If the CO limit value is exceeded, the colour of the measured CO values changes (red).

### 7.6. CO-purging



**NOTE**

Please note that the setting of the CO limit value with purging depends on the configuration of your analyser.



**NOTE**

Unit switching: 10000pmm values are displayed in%.

If the CO value exceeds the CO threshold, then the measured value is displayed red and air purging pump is activated. This will protect the CO electrochemical cell from too high CO gas concentrations.

If the CO value decrease below the CO threshold, then the CO value will be displayed again in black colour.

Air purging pump is still running and can be deactivated only by accessing the "menu" key and confirm "purge pump off"

The actual CO value will then be displayed again.

If a measurement with active purging will be stored, the device documented the device the CO value as CO limit value.

### 7.7. CO/H2 and CO high (optional)

If that exceeds CO the CO threshold, then to CO high, the measured value is red indicated - also the calculated values - is switched. The CO value exceeds 10.000 ppm to % is in such a way switched (example 1.00%).

If the CO value sinks below the CO threshold, then the red CO value becomes again black

Starting from this moment the purge pump can be switched off over the menu key again.

### 7.8. Performing Test program

This test program is made for testing facilities that will test these analysers with test gases and don't need to make any modifications. In this program you will only see measured values and no calculated values at all.



- ▶ Select Gas measurements.
- ▶ Press OK.
  - ⇒ The menu Selection meas. Program appears.
- ▶ Select Test program.
  - ⇒ The menu Test program appears.

### 7.9. Performing Ambient CO Test

In some countries the measuring program CO environment is demanded. The objective of this measuring program is the proof of CO concentration in the environment of the measuring point. In the case of the country setting in the main menu the menu option is indicated „Ambient CO test“.

- ▶ Perform a zero point measurement outside of the environment of the measuring location before you perform a CO Ambient Test.

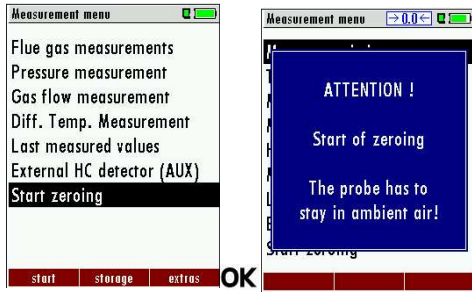

- ▶ Select Start zeroing.
- ▶ Press OK.
  - ⇒ A message appears.
  - ⇒ The zeroing is performed.
  - ⇒ After zeroing, you can start the CO Ambient test.

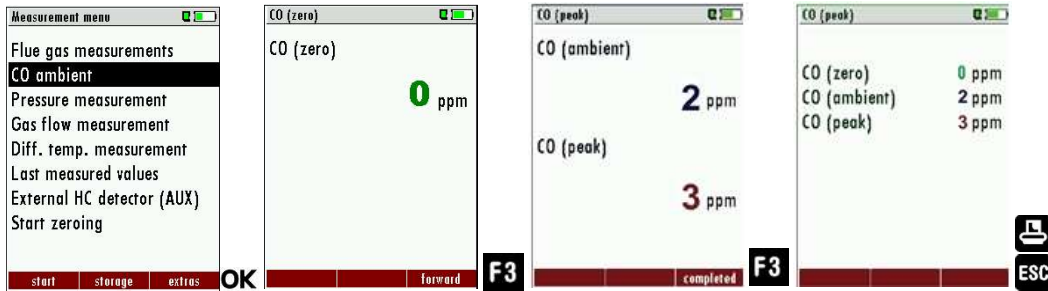

- ▶ Select CO ambient
  - ⇒ The menu CO (zero) appears. The current CO value (zeroing) as a check is indicated. (This value must be approx. 0 ppm!)
- ▶ Go to the measuring point.
- ▶ Press F3.
  - ⇒ The menu CO (peak) appears.
  - ⇒ The CO Ambient test is performed. The current CO (ambient) and CO (peak) values will be indicated.
- ▶ Press F3.
  - ⇒ The measurement is finished.
  - ⇒ The CO (zero) value, CO (ambient) value and the CO (peak) value are displayed.
- ▶ Press the printer key to print out the measurement results.
- ▶ Press the ESC key to return to the Measurement menu.

### 7.10. Temporary buffer

The analyser gives the possibility to set the momentary values into a temporary buffer during effecting and continuing the measurement.

- ▶ Later on, the values can be brought back from the temporary buffer to the measuring window in order to print them out or / and to save them.

#### Store measured values in the buffer

During an actual measurement you can set the actual values into the temporary buffer

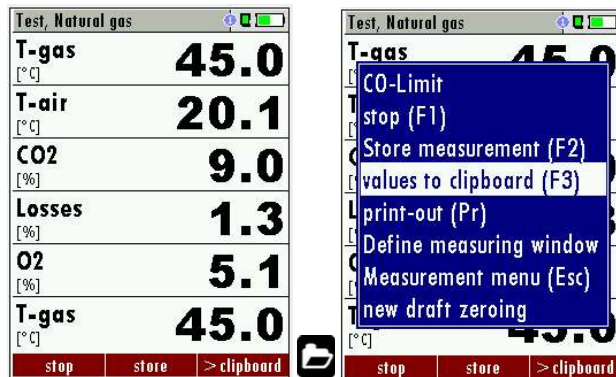

- ▶ Start a measurement.

☞ See also Chapter 7.1 Selecting the measuring program, Page 33.

- ▶ Press the Menu Key.

⇒ A selection list appears.

- ▶ Select values to clipboard.

⇒ The measured values are stored in the temporary buffer.

If offered, you can store measured values directly from the function key bar in the temporary buffer. **> clipboard**

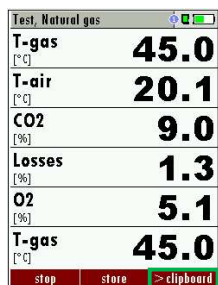

### Overwrite measured values in buffer

When the measurement is stopped, you can overwrite the displayed measured values with the measured values stored in the temporary buffer.

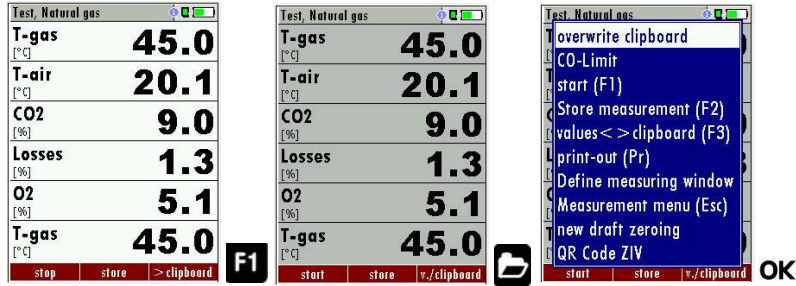

- ▶ Press F1.
  - ⇒ The measurement is stopped.
  - ⇒ The measured value window is highlighted in grey.
- ▶ Press the Menu Key.
  - ⇒ A selection list appears.
- ▶ Select overwrite clipboard.
- ▶ Press OK.

Now you can change the current values and the values of the temporary buffer with the key F3. This change of the actual values with the values of the temporary buffer memory can be executed several times one after the other

Now it is possible to print and save as usual one of both measurements.

### 7.11. Storing measured values

If in the function key bar "store" is indicated, you can store with the accompanying function key F2 or F3 the measurement in the data memory.

The function of the data memory is explained in chapter 8 Data Storage, Page 46.

**7.12. Printing measurement values**

The measurement results can be printed out on the Speedprinter (IR table printer, art. no. 62693) with the printer key.

► You must align the Speedprinter as follows:

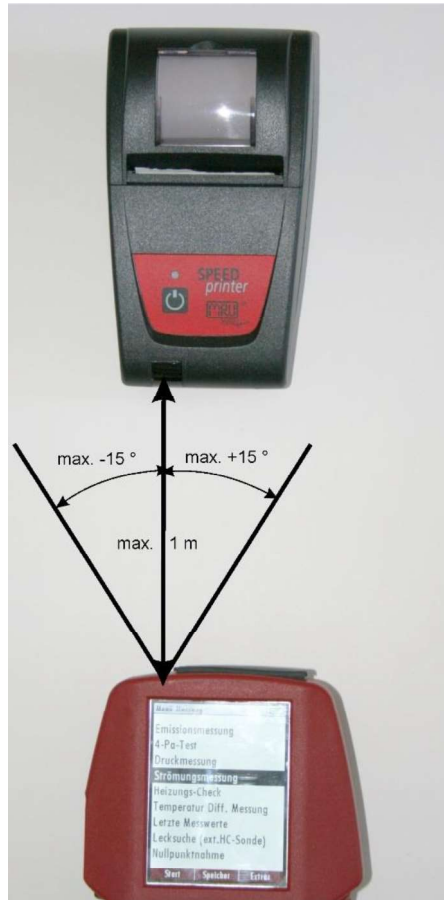

All values that can be seen in the measurement window on all three pages will be printed, double measurement values will only be printed once.

Further technical specifications as well as battery and paper rolls changes please see separate printer manual.



**NOTE**

If you want to print measurement results using the HSP580 High-Speed Bluetooth-Thermal Printer, refer to the user manual of the corresponding printer.

### 7.13. Terminate measurement

A running measurement can be stopped at any time by pressing the F1 key. The window changes colour and the measured values are frozen. All measured values available at the time of stopping are available in the analyser and can still be displayed. By pressing the ESC key, the analyser returns to Measurement menu.

### 7.14. Last measurement values

The analyser offers the possibility to continue working with the last measured values after the end of a measurement.

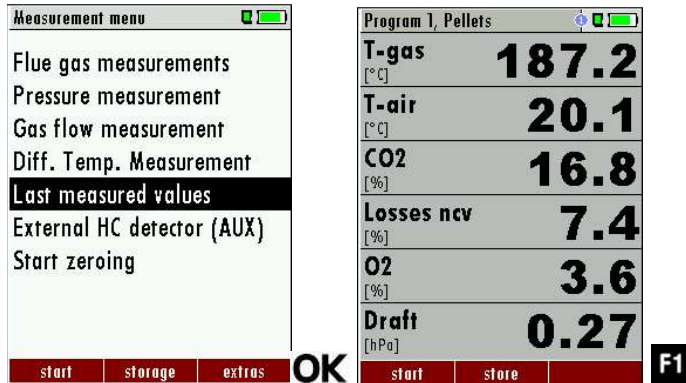

- ▶ Go to the Measurement menu.
- ▶ Select Last measured values.
  - ⇒ The measured value window with the last measured values appears.
- ▶ Press F1.
  - ⇒ The measurement is continued.

### 7.15. Pressure measurement

Pressure (4 values) is measured and saved to the selected measurement name. The actual measured value is displayed in the middle of the display. The 4 measurement names can be changed as desired.

The hose on the draft + connector must be connected for draft measurements.

The second hose on the Delta P- connector must be connected for differential measurement.

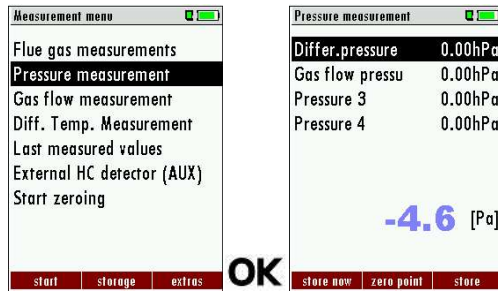

- ▶ Go to the Measurement menu.
  - ▶ Select Pressure measurement.
  - ▶ Press OK.
- ⇒ The Menu Pressure measurement appears.

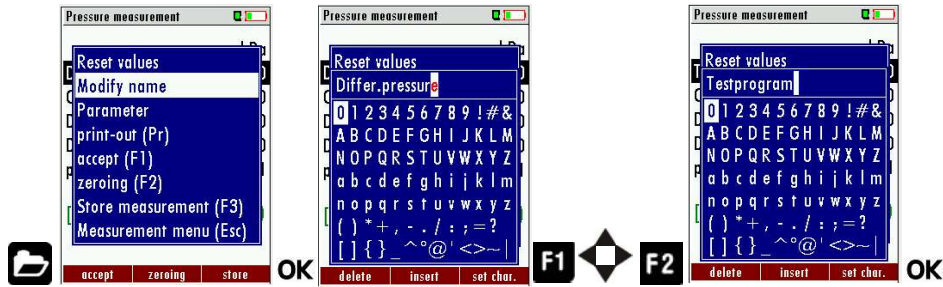

- ▶ If necessary, press the Menu Key to change the name.
  - ⇒ A selection list appears.
- ▶ Select Modify name.
  - ⇒ A window appears.
- ▶ Adapt the name to your needs.
- ▶ Press OK.
  - ⇒ The changed name appears in menu Pressure measurement.
- ▶ If necessary, press F1 to accept the current value.
- ▶ If necessary, press F2 to take a zero point.
- ▶ If necessary, press F3 to save the measured values

### 7.16. Differential temperature measurement (optional)

In the differential temperature measurement menu two temperatures can be measured simultaneously by using the T1 and T2 connectors. Both measured temperatures and the difference between the temperatures will be displayed.

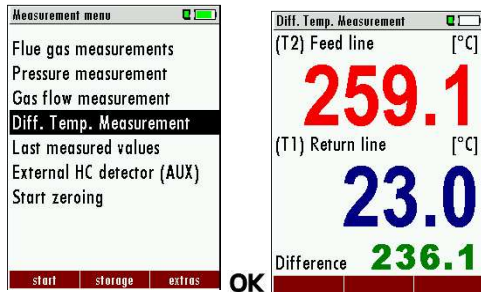

- ▶ Go to the Measurement menu.
- ▶ Select Diff. Temp. Measurement.
- ▶ Press OK.
  - ⇒ The menu Diff. Temp. Measurement appears.
  - ⇒ The temperatures T1, T2 and the difference are displayed.



#### NOTE

The accuracy of the difference temperature measurement is guaranteed only on use of the MRU temperature sensors.

## 8 Data Storage

### 8.1. Organizing data storage

The basis for the data storage of the analyser is saved sets of sites inside the analyser. Each site has a distinct site number as well as 8 additional free text lines for names and address.

The analyser can store up to 4,000 different sites.

New sites can be added in the analyser. Modifications can be done using an external PC program e.g. MRU Win.

#### NOTE



New sites created in the analyser will NOT be transferred back to the computer program. When transferring data from the analyser to the computer only measurement data will be transferred, identified by the site number that has been assigned to the measurement, when the measurement was saved.

Measurements are saved by assigning them to a site. Measurements can be single flue gas measurements, 4Pa tests, heating checks or other measuring programs available in the analyser.

### 8.2. Calling up information about data storage

In the menu item "storage" you select „memory info“ to get information about the actual memory volume. The part of free memory, the total number of the stored sites and the number of the measurements stored all together, split in the kind of the measurement is listed.

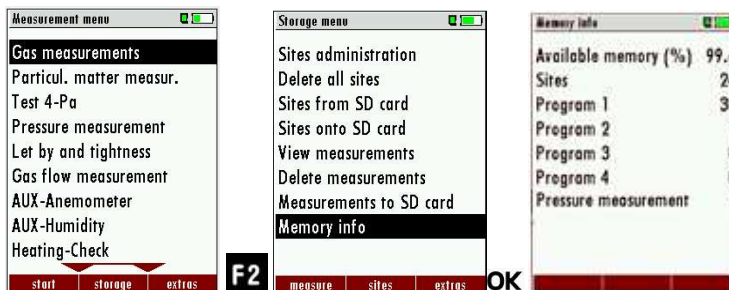

- ▶ Press F2
  - ⇒ The Storage menu appears.
- ▶ Select Memory info.
  - ⇒ The menu Memory info appears.
  - ⇒ Information on the data storage is listed.

### 8.3. Site administration

In the sub menu **Sites administration**, you can:

- view all data of the stored sites
- create new sites
- change date of existing sites
- delete sites



#### NOTE

New sites created in the analyser will NOT be transferred to a PC program

### Create new site

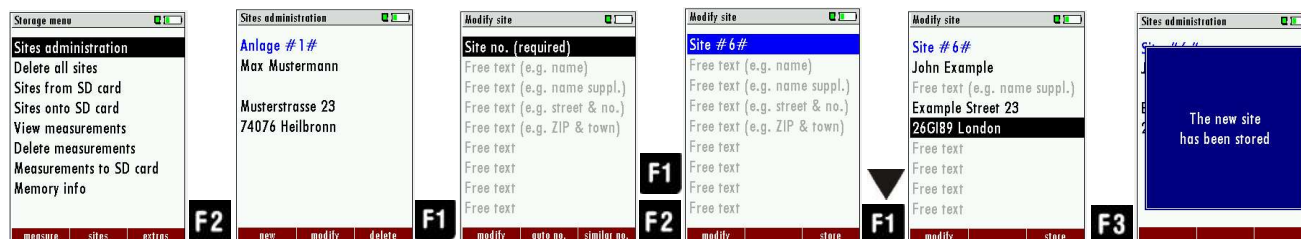

- ▶ Go to the Storage menu.
- ▶ Press F2.
  - ⇒ The menu Sites administration appears.
- ▶ Press F1.
  - ⇒ The menu Modify site appears.
- ▶ Press F1 to assign manually a site number to the site.
- ▶ Press F2 to assign automatically a site number to the site.
  - ⇒ The site is assigned a site number.
- ▶ Select the free text lines that you want to edit.
- ▶ Press F1.
  - ⇒ A window appears.
- ▶ Enter the desired content.
- ▶ If necessary, select further free text lines and fill them with content.
- ▶ Press F3.
  - ⇒ The site is stored.

## View sites



- ▶ Go to the Storage menu.
- ▶ Select Sites administration.
- ▶ Press OK.
  - ⇒ The menu Sites administration appears.
  - ⇒ Each stored site is displayed on a page with the coloured site number and eight additional free text lines.
- ▶ If necessary, scroll through the sites until you have found the desired site.

### NOTE



You also have the possibility to search for sites by setting a search mask.

☞ See also chapter Searching site, Page 48.

## Searching site

You have the possibility to enter certain parameters in order to search for particular sites. In the following example we will search for the site that is assigned to John Example.

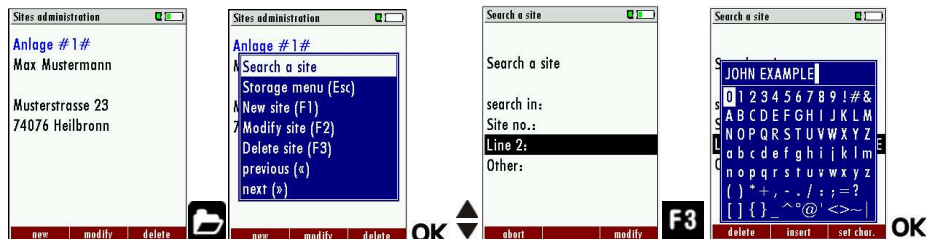

- ▶ Go to the menu Sites administration.
- ▶ Press the Menu Key.
  - ⇒ A selection list appears.
- ▶ Select Search a site.
- ▶ Press OK.
  - ⇒ The menu Search a site appears.
  - ⇒ You can choose to filter by Site number, by content in Line 2 or for the rest of the other text lines.

- ▶ Select a line in which you want to search for content.  
In this example, the search is performed in line 2.
- ▶ Press F3.
  - ⇒ A window appears.
- ▶ Enter the desired search term.  
In this example the search term is John Example.
- ▶ Press OK.
  - ⇒ The menu Search a site appears.
  - ⇒ The search term appears in the selected line.

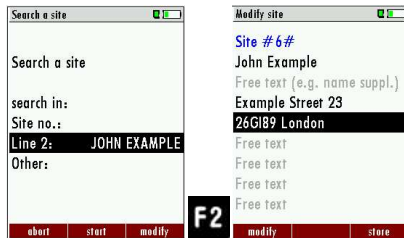

- ▶ Press F2.

The site that is assigned to John Example is displayed. If several sites were found, the total number is displayed in the header and you can scroll through these found sites.

### Changing sites



- ▶ Go to the Storage menu.
- ▶ Select Sites administration.
- ▶ Press F2.
  - ⇒ The menu Sites administration appears.
- ▶ Select the site that you want to change.
- ▶ Press F2.
  - ⇒ A bar appears.
- ▶ Select the free text lines that you want to change.
- ▶ Press F1.
  - ⇒ A window appears.
- ▶ Enter the desired changes.
- ▶ If necessary, select further free text lines and change the corresponding free text lines.
- ▶ Press F3.
  - ⇒ The changes are stored.

## Deleting sites

You can delete sites individually or delete all sites simultaneously.

### Deleting sites individually



- ▶ Go to the Storage menu.
- ▶ Select Sites administration.
- ▶ Press F2.
  - ⇒ The menu Sites administration appears.
- ▶ Select the site you want to delete.
- ▶ Press F3.
  - ⇒ A message appears.
- ▶ Select continue to delete the site
- ▶ Select abort to retain the site.
- ▶ Press OK.
  - ⇒ Depending on the selection, the site is deleted or retained

### Deleting all sites.



- ▶ Go to the Storage menu.
- ▶ Select Delete all sites.
- ▶ Press OK.
  - ⇒ A message appears.
- ▶ Select continue to delete all sites.
- ▶ Select abort to retain all sites.
- ▶ Press OK.
  - ⇒ Depending on the selection, the site is deleted or retained

## 8.4. Data transfer using SD card

The data exchange format is CSV. A character-separated values (CSV) file is a simple text format for a database table. Each record in the table is one line of the text file. Each field value of a record is separated from the next by a character. Optima 7 uses a semi-colon ';' as value separator (other implementations use sometimes a comma). Implementations of CSV can often handle field values with embedded line breaks or separator characters by using quotation marks or escape sequences. CSV is a simple file format that is widely supported, so it is often used to move tabular data between different computer programs, for example Microsoft Excel™ or Access™, that support the format. Also, other computer programs offer this type of interface because it is widely spread and easy to use.

The following functions are available from Software Version 1.11 and higher:

- 1.Importing sites
- 2.Exporting sites
- 3.Exporting combustion tests
- 4.Exporting differential pressure measurements

### Importing sites

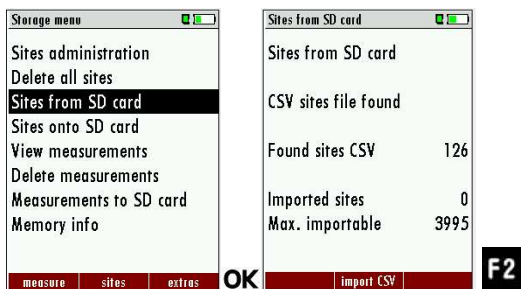

- ▶ Go to the Storage menu
- ▶ Select sites from SD card
  - ⇒ The menu Sites from SD card appears.
- ▶ Press F2, to select Import CSV.

With this function you can Import Sites which have been created on a computer or another Analyzer.

The File name must have the name "anlagen.csv"(anlagen = German for sites). The file has no column heading that means that the first line already has user data. Each line has a minimum of 9 columns (with 8 semi-colons) and the first field in the line will be the site number. All data will be imported as long a site number is available. Per field a maximum of 24 characters will be imported, too long words will be cut off.

Example file with 8 valid sites (4 with 9 lines and 4 with less lines):

```
A1-Z1;A1-Z2;A1-Z3;A1-Z4;A1-Z5;A1-Z6;A1-Z7;A1-Z8;A1-Z9
A2-Z1;A2-Z2;A2-Z3;A2-Z4;A2-Z5;A2-Z6;A2-Z7;A2-Z8;A2-Z9
A3-Z1;A3-Z2;A3-Z3;A3-Z4;A3-Z5;A3-Z6;A3-Z7;A3-Z8;A3-Z9
A4-Z1;A4-Z2;A4-Z3;A4-Z4;A4-Z5;A4-Z6;A4-Z7;A4-Z8;A4-Z9
A5-Z1;A5-Z2;A5-Z3;A5-Z4;;;;;
A6-Z1;A6-Z2;;A6-Z4;;;;;
A7-Z1;;;A7-Z4;;;;;
A8-Z1;;;;;;;
```

Example file with 2 invalid sites (1 with not enough fields and 1 with missing site number):

```
A1-Z1;A1-Z2
;A1-Z2;A1-Z3;A1-Z4;A1-Z5;A1-Z6;A1-Z7;A1-Z8;A1-Z9
```

**NOTE**



While importing data from the SD Card to the analyser there is no check for double site numbers (Line 1), neither inside of the file that is imported nor between the file and the sites already inside the analyser. The analyser can easily handle double site numbers but you could face problems with double site numbers when exporting them again to a computer program (see also Export of Measurements).

However, the analyser marks the files that have been imported successfully. If you try to import a file with the same analyser that is already in the analyser you will get a red information screen.

## Exporting sites

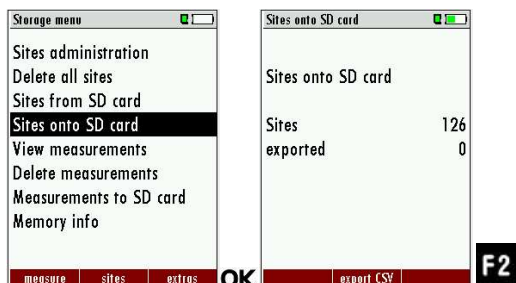

- ▶ Go to the Storage menu.
- ▶ Select Sites onto SD card.
- ▶ Press OK
  - ⇒ The menu Sites onto SD card appears.
- ▶ Press F2.
  - ⇒ The sites are exported.

This function can be used for an analyser back up or if you wish to supply the analyser information to a computer program or another analyser. This is very handy if you have made some modifications inside the analyser (site) for example if you have modified the phone number of a customer and this modification needs to be updated in the computer software, or if a second analyser needs to have the same site information.

The File format it's the same as described above „Import of Sites“.

Only the file name is different, the file name will be ‚ANLxxxx.csv‘, in which the xxxx are continuing 5-digit numbers with leading zeros. If the file must be imported into another analyser, the file must first be renamed into „anlagen.csv“.

## Exporting combustion measurements

This function is used to export the measurements from the analyser to a computer program.

This function is not suitable for back up or for the transfer to another analyser because the exported file cannot be imported again!

The created file has the name ‚EMIxxxx.csv‘, in which the xxxx are continuing 5-digit numbers with leading zeros.

The created file has a column header with the following information: Site number, Date/Time, Measuring program name, Fuel type, CO<sub>2</sub>max, O<sub>2</sub>reference, and all measured values that the analyser can measure as well as the soot numbers, Derivate and T-Boiler.

Example:

	A	B	C	D	E	F	G	H	I	J	K
1	Site no.	Date & time	meas.progra	fuel type	CO2max [%]	O2ref [%]	T-gas [°F]	T-air [°F]	Dewpoint [°F]	O2 [%]	CO2 [%]
2	BOILER	THU 30.09.20	Program 1	Natural gas	11.7	3.0	--	73.5	--	21.0	--
3	BOILER	THU 30.09.20	Program 1	Natural gas	11.7	3.0	--	73.0	--	21.0	--
4	BOILER	THU 30.09.20	Program 1	Natural gas	11.7	3.0	--	73.0	--	21.0	--
5	BOILER	THU 30.09.20	Program 1	Natural gas	11.7	3.0	--	72.5	--	21.0	--
6	BOILER	FRI 01.10.20	Program 1	Natural gas	11.7	3.0	--	72.5	--	21.0	--
7	A FURNACE	TUE 05.10.20	Program 1	Natural gas	11.7	3.0	81.0	--	113.0	11.7	5.2
8	A FURNACE	TUE 05.10.20	Program 1	Natural gas	11.7	3.0	81.0	--	113.0	11.7	5.2
9	A FURNACE	TUE 05.10.20	Program 1	Natural gas	11.7	3.0	82.5	--	112.5	11.7	5.1
10	A FURNACE	TUE 12.10.20	Program 1	Natural gas	11.7	3.0	84.5	--	132.5	2.7	10.2

**Exporting differential pressure measurements.**

The same function as Export of combustion tests only the file name is different.

The created file has the file name "DDMxxxxx.csv", in which the xxxxx are continuing 5-digit numbers with leading zeros.

The created file has a column header with the following information: Site number, Date/Time, as well as 4 saved pressure measurements.

**8.5. Measurement in Data storage**

**Viewing measurements**

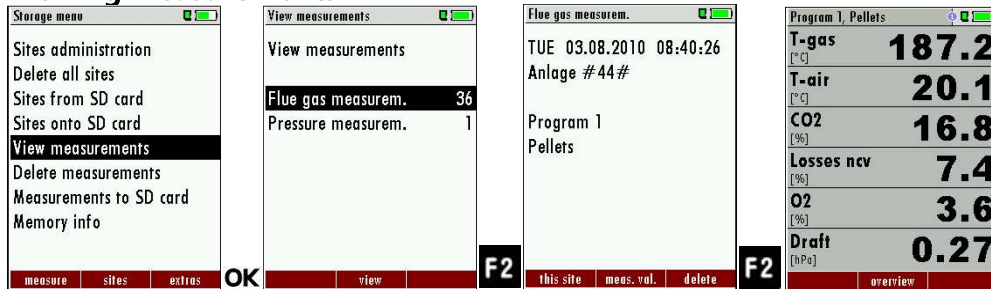

- ▶ Go to the Storage menu.
- ▶ Select View measurements.
- ▶ Press OK.
  - ⇒ The menu View measurements appears.
  - ⇒ An overview of the number of stored measurements according to the measurement type appears.
- ▶ Select the desired measurement type.
- ▶ Press F2.
  - ⇒ Then you receive first a page with context information to the stored measurement. Scroll with the arrow keys by the context information of the stored measurements.
- ▶ Press F2.
  - ⇒ Measured value are displayed the measured data of the stored measurement in detail, available in 3 measuring value pages, as they are defined in the measuring value window.
- ▶ With ESC you return to the context information of the measurement.

You have the possibility to display only those data that are assigned to a single site:

- either F1 = „this site“ while a measurement of the desired site is displayed.  
With F1 = „all sites“ you cancel this filter again.
- or while you select with the menu key the function "search a site" and execute, as described in the chapter site administration.

### Deleting measurements

You are able to

- delete single measurements, while they are displayed – press the key F3 = "delete" .
- or delete all measurements of a measuring type

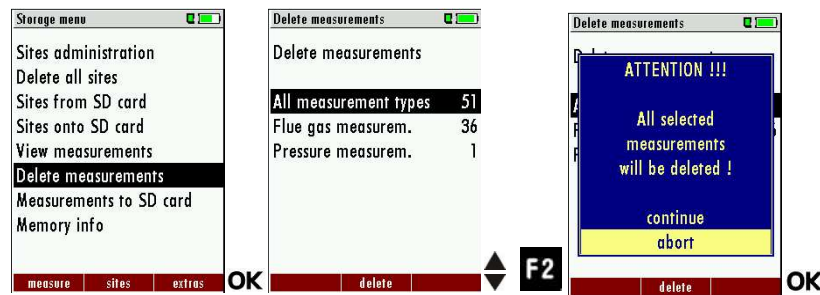

- ▶ Go to the Storage menu.
- ▶ Select Delete measurements.
  - ⇒ The menu Delete measurements appears.
- ▶ Select which measurement type you want to delete.
- ▶ Press F2.
  - ⇒ A message appears.
  - ⇒ Select continue to delete all measurements.
  - ⇒ Select abort to retain all measurements.
- ▶ Press OK.
  - ⇒ Depending on the selection, the measurement data are deleted or retained.

## Transferring measurements to SD-Card (Option)

The analyser offers the possibility to export all stored measurements to a SD card.

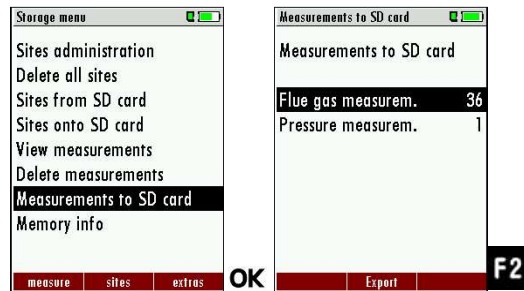

- ▶ Go to the Storage menu
- ▶ Select Measurements to SD card.
- ▶ Press OK.
- ▶ Select the desired measurement type.
- ▶ Press F2.
  - ⇒ The selected measurement type is transferred to the SD card

During the data export the display reads „please wait“. A write error to SD card is reported by the instrument. Make sure that the SD card is not write protected.

The data are stored as a csv-file (e.g., EMI01032.csv) on the SD card. The filename exists of a sequential number which fixes the device.

This file is editable on your Notebook/PC with a program like e.g. Microsoft® EXCEL or OpenOffice® Calc.

With possible problems with the using of your computer programs please read your software documentations or ask your software dealer.

## 9 Extras / Adjustment

The analyser is delivered in a standard software configuration which should cover most needs. However, there are many ways to tailor the settings to your individual needs if required. The possibilities are highly flexible and individual adaptable.

Use the variable possibilities to adapt your analyser to your own needs and customize the measurement menu, the measurement window, the printer output and many other features. Usually this is something you will do once you receive the analyser, once you have adapted your analyser you will most probably don't make much changes in future, but you can whenever you need and want to do so.

After you have made any changes in the configuration, you should switch off the analyser to save all the changes that have been made. Next time that you start up the analyser, all changes will have been made

### 9.1. Service calibration menu

The Maintenance adjustment menu is secured with a Pin Code to protect it against unauthorized users.

If you enter a wrong pin code you will be exited into the "Extra Menu" again.

Please contact MRU GmbH if you need the Pin Code for your analyser. Press the Enter key if you should have landed in this menu by accident and you will be exited into the "Extra Menu" again.

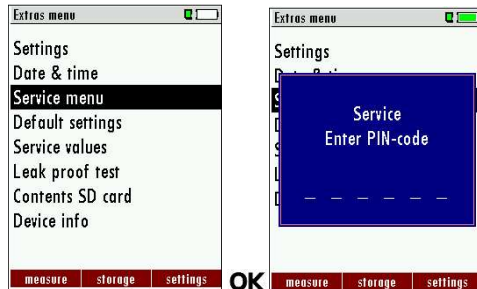

- ▶ Go to the Extras menu.
- ▶ Select Service menu.
- ▶ Press OK.
  - ⇒ A window for entering the PIN-code appears.
- ▶ Enter the PIN-code
  - ⇒ If you enter the PIN-code correctly, you will have access to the service menu.
  - ⇒ If the PIN-code is entered incorrectly, you will be returned to the Extras menu.

## 9.2. Default settings

The analyser will be reset to original delivery settings.



**NOTE**

With the default setting, all individual settings are lost.

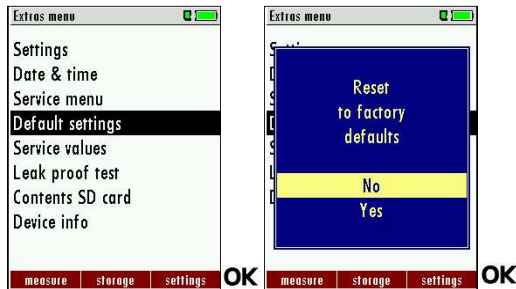

- ▶ Go to the Extras menu.
- ▶ Select Default settings.
- ▶ Press OK.
  - ⇒ A window appears.
- ▶ Select "No" to not reset the default settings.
- ▶ Select "Yes" to reset the analyser to default settings.
- ▶ Press OK.
  - ⇒ Depending on the selection, the analyser is reset to the default settings or not.

O2 reference values are set to default:

Settings:

LCD brightness (%)	50
LED condensate trap	75
Helpful hints	ON
Printer type	MRU
Core flow search	AN
Printout variant	Short
Keyboard beep	ON

### 9.3. Service values

Should your analyser display an error message after zeroing (for example: „O2-Sensor not OK"), then you can use the Service value menu to get detailed information about possible defects. In this menu you will see all service values of the sensors and also other parameters.

In case of a defect contact the MRU service department. The MRU service technician will ask you about these values or he will ask you to send them by fax or email.

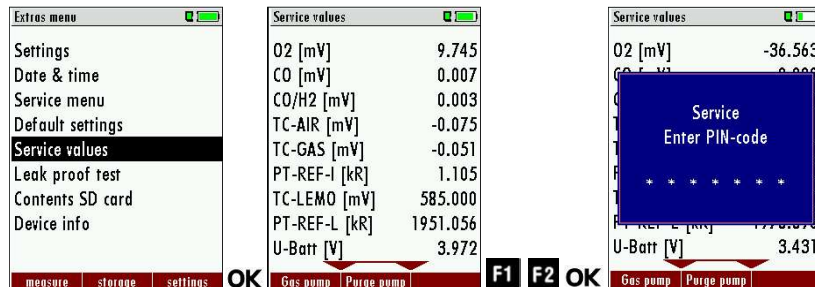

- ▶ Go to the Extras menu.
- ▶ Select Service values.
- ▶ Press OK.
  - ⇒ The menu Service values appears.
- ▶ Press F1 to switch the gas pump function test on or off.
- ▶ Press F2 to switch the function test of the purge pump on or off.
- ▶ Press OK.
  - ⇒ A window for entering the PIN-code appears.
- ▶ Enter the PIN-code
  - ⇒ The selected function test is switched on or off.

### 9.4. Performing leak test

With the leak proof test, the system is checked by the device (incl. the condensate separator) up to the probe spike on undensity. The internal gas pump generates in addition a sub pressure which is measured over the built-in draft sensor and is observed for a period of 10 seconds. Based on the decrease of pressure the leakiness of the system will be determined.

#### Operation:

- ▶ The leak proof test cap # 61382 (for probe tubes Ø 8 mm) must be put on the probe spike.



Art.-# 61382

**NOTE**



With dirt and soot particles on the probe tube the test cap will not seal properly.

▶ The probe tip must be cleaned before you start this test!

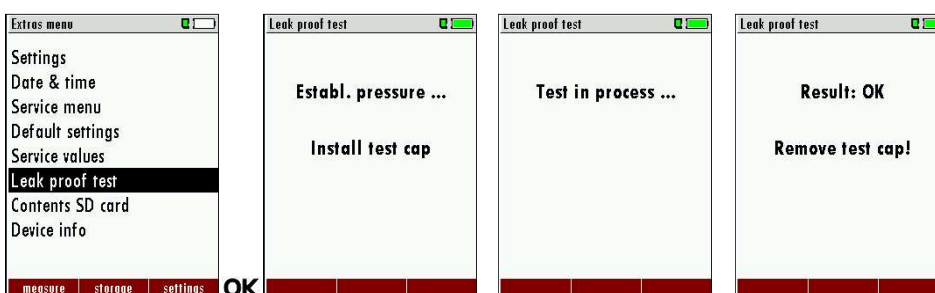

- ▶ Go to the Extras menu.
- ▶ Select Leak proof test.
- ▶ Press OK.
  - ⇒ The menu Leak proof test appears.
- ▶ Ensure that the leak test cap is plugged in.
  - ⇒ Pressure is established.
  - ⇒ A 10-second test is running.
  - ⇒ A message appears whether the leak proof test was passed or not.
- ▶ Remove the proof test cap.



If of the leak proof test is not passed the probe must be checked including the hosing as well as the condensate separator.

If no undensity is ascertained in these external parts the OPTIMA 7 Combustion Analyzer has to be checked in a service department (worldwide service departments see [www.mru.eu](http://www.mru.eu))

### 9.5. Contents SD card

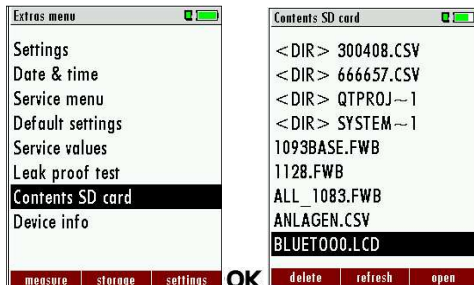

- ▶ Go to the menu Extras.
- ▶ Select Contents SD card.
- ▶ Press OK.
  - ⇒ The menu Contents SD card appears.
  - ⇒ The files stored on the SD card are displayed.
- ▶ Select a file.
- ▶ If necessary, press F1 to delete the file.
- ▶ If necessary, press F2 to refresh the file.
- ▶ If necessary, press F3 to open the file.

### 9.6. Contents Analyzer information

The analyser information can be viewed in the main Extras menu and the sub menu Device info.

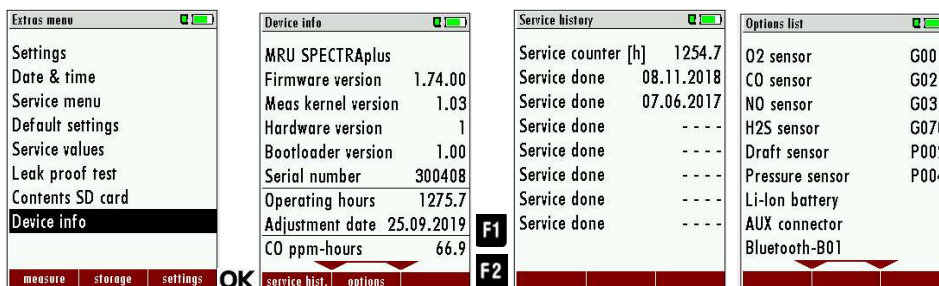

- ▶ Go to the Extras menu.
- ▶ Select Device info.
  - ⇒ The menu Device info appears.
- ▶ Press F1.
  - ⇒ The menu Service history appears.
  - ⇒ The date of the last 7 service procedures appears.
- ▶ Press F2.
  - ⇒ The menu Options list appears.
  - ⇒ The installed options are displayed.

## 10 Maintenance and care

The analyser requires very little maintenance to maintain its value over a long period

- occasionally: cleaning the probe and the probe hose.
- after each measurement: Pull off the gas sampling hose on the analyser, so that the hose can dry.
- If not used for a longer period of time, charge the battery first.
- Charge the battery approximately every 4 weeks.

### 10.1. Maintenance

An annual inspection and, if necessary, calibration of the sensors by an MRU service centre ( ) is recommended to maintain their value

#### NOTE



Please note that correct operation of the analyser is only ensured if the sensors are adjusted regularly.

- ▶ Depending on the intensity of use, the sensors have to be adjusted / calibrated 1-2 times a year.



### 10.2. Service messages

A message is displayed after 1,000 hours or 11 months.

If the analyser has the optional guarantee extension of 60 months this will be shown in another window. Confirm these messages with F2= OK. The next time you switch on, you will be reminded to carry out the annual service.

A complete service at an MRU service centre (MRU service centres can be found at ) includes the function check and calibration or cleaning of the following components:

Sensors, pumps, internal / external hose lines, battery, draft, electronics, time and date, temperature inputs, gas sampling probe, condensate separator.

## 11 Appendix

### 11.1. Technical data

<b>General data</b>	
Operating temperature	+5°C - +45 °C / 41°F – 113°F
Rel. Humidity, non-condensing	95%
Storage Temperature	-20°C ... +50°C / -4°F – 122°F
Internal Battery Pack, operating hours	Li-Ion, 20h
Power supply	100 - 240 V / 5V DC / 1200 mA
Weight with 2 sensors	750g /1.65lbs
Size	244x113x54 mm / 4.3x 8.8 x2.04 in
Housing material	PA6
IP protection with protection cap	IP30
Max suction range gas pump	150 hPa
gas flow typ.	60 l/h
<b>Measurement accuracy data</b>	
<b>Electrochemical Sensor</b>	<b>O<sub>2</sub></b>
Measuring Range	0 - 21 %
Resolution (standard)	0,1 %
Resolution (option)	0,01 %
Abs. Accuracy	± 0,2 Vol.%
Response Time T90	< 20s
Years expected lifetime (@air)	2
CO <sub>2</sub> tolerance up to	20 Vol.%
<b>Electrochemical Sensor</b>	<b>O<sub>2</sub> Long Life</b>
Measuring Range	0 - 21 Vol.%
Resolution (standard)	0,1 %
Resolution (option)	0,01 %
Abs. Accuracy	± 0,2 Vol.%
Response Time T90	< 20s
Years expected lifetime (@air)	3
CO <sub>2</sub> tolerance up to	100 Vol.%
<b>Electrochemical Sensor</b>	<b>O<sub>2</sub> Very Long-Life</b>
Measuring Range	0 - 21 Vol.%
Resolution (standard)	0,1 %
Resolution (option)	0,01 %
Abs. Accuracy	± 0,2 Vol.%
Response Time T90	< 20s
Years expected Life Time (@air)	4
CO <sub>2</sub> tolerance up to	100 %

(requires recovery time of double the exposure time for CO <sub>2</sub> > 20 Vol%)	
<b>Electrochemical Sensor</b>	<b>Measuring range extension up to 25 % (Option #62414)</b>
Measuring Range	0 - 25 Vol.%
Resolution	0,1 %
Abs. Accuracy.	± 0,2 Vol.%
Response Time T90	< 20s
<b>Electrochemical Sensor</b>	<b>CO</b>
H <sub>2</sub> compensated	
Nom. Measuring Range	0 - 10000 ppm
Overload Range	< 20000 ppm
Resolution	1 ppm
Accuracy abs. / reading	± 10 ppm 5% (0 – 4000 ppm) 10% (> 4000 ppm)
Response Time T90	< 40s
<b>Option</b>	<b>CO low</b>
Measuring Range	500 ppm
Resolution	0,1 ppm
Accuracy	± 2ppm / 5%
<b>Electrochemical Sensor</b>	<b>CO high (Option #63057)</b>
Nom. Measuring Range	0 - 4000 ppm
Overload Range	< 20000 ppm
Resolution	1 ppm
Accuracy abs. / reading	± 100 ppm / 5% (0 - 4000 ppm) 10 % (> 4000 ppm)
Response Time T90	< 40s
<b>Electrochemical Sensor</b>	<b>CO very high (Option #63134)</b>
Nom. Measuring Range	0 - 40.000 ppm / (0 - 4%)
Overload Range	< 100.000 ppm / (<10%)
Resolution	0. 10000 : 1 ppm >= 1% : 10 ppm / (0,001%)
Accuracy abs. / reading	± 200 ppm / 5% (0 - 40.000 ppm / (0-..%)) 10% (> 100.000ppm / (<10%))
Response Time T90	< 40s

<b>Electrochemical Sensor</b>	<b>NO (Option #63058)</b>
Nom. Measuring Range	0 - 1000 ppm
Overload Range	< 5000 ppm
Resolution	1 ppm
Accuracy abs./reading	± 5ppm
	5% (0 - 1000 ppm)
	10% (> 1000 ppm)
Response Time T90	< 30s
<b>Option</b>	<b>No low</b>
Measuring Range	0 - 300 ppm
Resolution	0,1 ppm
Accuracy	2 ppm / 5%
<b>Electrochemical Sensor</b>	<b>NO<sub>2</sub></b>
Nom. Measuring Range	0 - 200 ppm
Overload Range	< 1000 ppm
Resolution	1 ppm
Accuracy abs./reading	± 5ppm / 5% (0 - 200 ppm)
	10% (> 200 ppm)
Response Time T90	< 40s
<b>Option</b>	<b>NO<sub>2</sub> low</b>
Measuring Range	0 - 300 ppm
Resolution	0,1 ppm
Accuracy	4 ppm / 5%
<b>Electrochemical Sensor</b>	<b>SO<sub>2</sub></b>
Nom. Measuring Range	0 - 2000 ppm
Overload Range	< 5000 ppm
Resolution	1 ppm
Accuracy abs./reading	± 10 ppm /
	5% (0 - 2000 ppm)
	10% (> 2000 ppm)
Response Time T90	< 40s
<b>Option</b>	<b>SO<sub>2</sub> low</b>
Measuring Range	0 - 300 ppm
Resolution	0,1 ppm
Accuracy	4 ppm / 5%

<b>Electrochemical Sensor placed on additional position (depending on configuration)</b>	<b>H<sub>2</sub>S</b>
Nom. Measuring Range	0 - 500 ppm
Overload Range	< 2000 ppm
Resolution	1 ppm
Accuracy abs./reading	± 5 ppm / 5% (0.- 500 ppm) 10% (> 500 ppm)
Response Time T90	< 40s
<b>Electrochemical Sensor placed on additional position (depending on configuration)</b>	<b>H<sub>2</sub>S</b>
Nom. Measuring Range	0 - 2000 ppm
Overload Range	< 5000 ppm
Resolution	1 ppm
Accuracy abs./reading	± 10 ppm / 10%
Response Time T90	< 40s
<b>Non-dispersive Infrared Measurement (NDIR)</b>	<b>CO<sub>2</sub></b>
Nom. Measuring Range	0 - 40 Vol.%
Resolution	0,01 Vol.%
Accuracy abs./reading	± 0,3 Vol.% / 3%
Response Time T90	< 35 s
<b>Non-dispersive Infrared Measurement (NDIR)</b>	<b>CH<sub>4</sub></b>
Nom. Measuring Range	100 - 40000 ppm
Resolution	10 ppm
Accuracy abs./reading	± 400 ppm / 5%
Response Time T90	< 35 s
<b>Temperature measurement</b>	<b>T1, T2</b>
Number of thermocouple type K input	2
Measuring Range	-40 °C - 1200 °C
Accuracy	±2°C/ 0,5%
<b>Flue gas temperature (using MRU probe)</b>	<b>T<sub>A</sub></b>
Measuring Range with high grade steel probe pipe	0 - 800°C
Measuring range with Inconel probe pipe	0 - 1100°C
Accuracy abs. / reading	±2°C/ 0,5%

<b>Ambient temperature (using MRU sensor)</b>	<b>T<sub>i</sub></b>
Measuring Range with ambient temperature probe	0 - 100°C
Accuracy	1 °C
Accuracy abs./reading	±1°C
<b>Draft</b>	
Measuring Range	± 100 hPa
Accuracy abs. / reading	0,02 hPa / 1%
<b>Differential Pressure</b>	
Measuring Range	± 300 hPa
Accuracy abs. / reading	0,02 hPa / 1%

### 11.2. Analysis and calculations

<b>Calculated values</b>	
	<b>CO<sub>2</sub></b>
Measuring range (fuel type dependant)	0 - CO <sub>2</sub> max
Accuracy abs.	± 0,3 Vol. %
Air ratio	
Measuring Range	1 - 20
Excess Air	
Measuring Range	0 - 999 %
PI (Poison Index / Ratio)	
Measuring Range	0.0001 - 10.0
Dew point	
	C
Losses qA	
Measuring Range	0 - 99,9%
Efficiency	
Measuring Range	0 - 120%
Measurement values available as	Mg/Nm <sup>3</sup>
	O <sub>2</sub> Ref
	mg/kWh
	NO <sub>x</sub> : mg/Nm <sub>3</sub> NO <sub>2</sub>

Measured values	Unit
O <sub>2</sub>	[%]
CO	[ppm]
CO	[%]
NO	[ppm]
NO <sub>2</sub>	[ppm]
SO <sub>2</sub>	[ppm]
Temp. Ambient air (Thermo-Element)	[°C] [°F]
Temp. Flue gas (Thermo-Element)	[°C] [°F]
CO	[ppm]
Draft	[hPa]

Available conversions of CO	CO
[ ppm ] related to. on 0% rest O <sub>2</sub> (undiluted)	X
[ ppm ] related to. on fuel type dependent O <sub>2</sub> reference value	X
[ mg/m <sup>3</sup> ]	X
[mg/kWh]	X
[mg/MJ]	X
[ mg/m <sup>3</sup> ] on fuel type dependent O <sub>2</sub> reference value	X

Continuously calculated values	Unit
CO <sub>2</sub>	[%]
Efficiency ETA	[%]
Efficiency condensed	[%]
Losses	[%]
Losses condensed	[%]
Lambda	-
Dew point	[°C] [°F]
CO/CO <sub>2</sub> ratio	[%]

Losses and efficiency are calculated by means of net calorific value. These values are then referenced for the gross calorific value for condensing boilers only. (Efficiency > 100)

The calculations of efficiency and exhaust losses are performed using Sievert's formula.

For further information please contact MRU GmbH. ( )

### 11.3. Text input

A number of texts and names can be changed to your own needs.  
 (For example: the names of the user defined fuel types, site names, the names of the measurement programs)

When you select the text input, the following window will pop up:

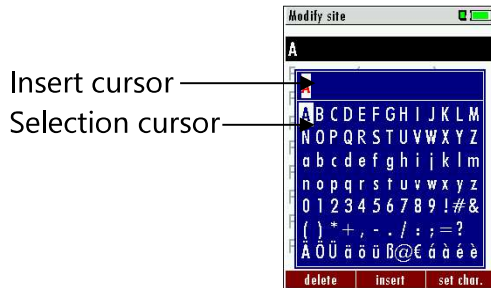

▲, ▼, ←, →	Select a letter, number or sign
<b>F1 – delete</b>	The letter left of the cursor will be deleted
<b>F2 – insert</b>	Selected letter or number will be inserted
<b>F3 – over write</b>	Selected letter or number will over write the current letter or number
<b>ESC</b>	Abort the window, changes will NOT be saved

### 11.4. Asking user for decision

The analyser requires confirmation of the user decision for various functions

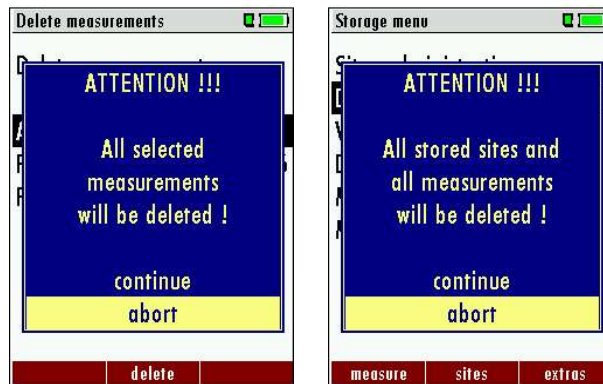

▲, ▼	Select a line
<b>OK</b>	Confirm the action
<b>ESC</b>	Abort the window, changes will NOT be saved

## 11.5. Firmware update

### Install the new software version in the analyser

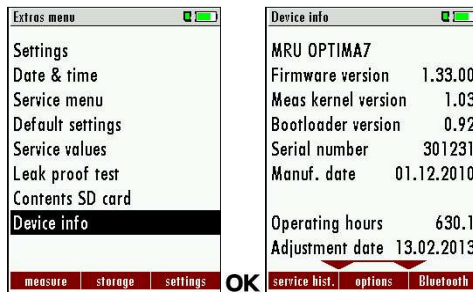

- ▶ Go to the Extras menu.
- ▶ Select Device info.
  - ⇒ The menu Device info appears.
  - ⇒ In the first line the Firmware version appears, for example 1.33.00.

For the case that there should be problems by the update we need some information of you.

Please write down your Firmware-Version \_\_\_\_\_

Please write down your serial number \_\_\_\_\_

### Performing and checking the update

#### Prepare SD-Card

You need the latest file 'All\_1083.fwb'. In case you get it in a zip archive you have to extract it before usage. This file contains all firmware types and the analyser will extract the correct type out of this file automatically.

#### How do I carry out the update?

#### NOTE



The display becomes dark while the update starts.

- ▶ Please wait about 25 seconds.
- ▶ Do not press any key during this time.
- ▶ Leave the SD card in the analyser.

The SD card may only be removed when the analyser starts again

- ▶ Copy the file „All\_1083.fwb” to a SD card in the root directory (that means in no directory)
- ▶ Switch on the analyser.
- ▶ Insert the SD card into the analyser.

- ⇒ In the most cases a message "Searching firmware, please wait..." will be displayed for some seconds.
- ⇒ Now the request "Firmware found Install firmware?" appears.
- ▶ Confirm with „install“.



**NOTE**

During the firmware update the red LED behind the condensate separator (water trap) lights up constantly.

- ⇒ The file is now checked, for a few seconds a corresponding message appears
- ⇒ Then the display becomes dark for about 25 seconds
- ⇒ Then the analyser will reboot with the new firmware
- ▶ Confirm the message „New Firmware installed“ with OK.
- ▶ Switch off the device again after the successful update.
  - ⇒ The next time the analyser is switched on, all new functions will be available.
- ⇒

**How do I identify if the update was successful?**

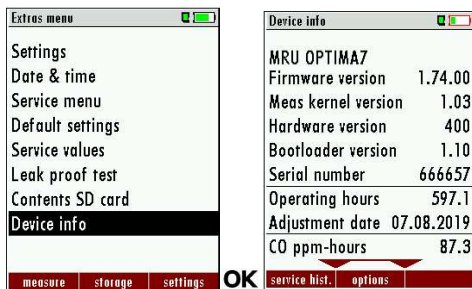

- ▶ Go to the Extras menu.
- ▶ Select Device info.
  - ⇒ The menu Device info appears.
  - ⇒ In the first line the new firmware version must be displayed. In this example the new firmware version 1.74.00 appears.

**What can I do if the old firmware version is still displayed?**

- ▶ Repeat the update process.

**In case of error**

**What to do if there were problems with the update?**

In case of an error, the red LED of the condensate separator flashes. The inserted SD card was not identified then. (Check that the SD card is correctly inserted and perform a reset by pressing the ESC and ON keys simultaneously).



**Where can I get help if the update was not successful?**

Please contact your responsible sales representative or via email:

**11.6. Using the USB Port**

This port is used for data transfer from your analyser to your PC / Laptop using the MRU Online View (Version 2.XX). The first time you want to use your analyser for data transfer to your PC or laptop, you have to "mate" the OPTIMA 7 and your PC / Laptop.

Your PC / Laptop will recognize the OPTIMA 7 as USB- HID (Human Interface Device).

Check list:

1. Switch on the OPTIMA 7
2. Connect the USB cable to the OPTIMA 7
3. Connect the USB cable into a free USB port at your PC/Laptop
4. The PC/Laptop must be powered on
5. The above seen information „New hardware found“ will be displayed above the USB-Icon of your PC/Laptop

**11.7. Troubleshooting**

**Troubleshooting the analyser**

1. Effect	2. Error indication	3. Cause	4. Solution
Device cannot be switched off by pressing the OFF key.	LED behind the condensate separator is on and the LCD display is dark	Device does not react on any key.	Press ESC and ON simultaneously!  EMERGENCY OFF  After this, the date and time have to set new.
Inside of the device is too cold, device not ready for operation.	Display indication: "Device too cold" or audible sound every 5 sec..	e.g. device was stored in a cold place during winter.	Put the device to a warm room and wait
Measuring values are not correct		Sensors already get in touch with the gas during calibration.	Vent device with fresh air and re-start!

No measurement possible		Device cannot be switched on or does not react after being switched on.  Battery discharge	Connect the device to the line power in order to charge the battery.
Measurement without exact temperature values.	Temperature indication: - - - , - °C	Thermoelement defective, balancing network interrupted or not connected.	Call our after-sales service.  Remove probe from the gas duct and condensate from the probe tube.
Wrong measuring values	Measuring range exceeded:  Value O <sub>2</sub> too high Values CO and CO <sub>2</sub> to low	Connection probe – device not correct. Leakage at probe / tube / condensate separator, pump does not suck correctly	Effect tightness test!  By visual control of probes, tubes condensate separator, leaking parts could be found.
Wrong measuring values	Gas temperature is too hot or alternates	Probe is not plugged in correctly, defective cable in the probe line, formation of condensate at the probe tip.	Check probe plug respectively probe line regarding damages (loose connection), remove condensate from the probe tip.

**Troubleshooting condensate separator**

1. Effect	2. Cause	3. Solution
Dirt and / or humidity inside the device No filter effects Sensor failure Pump failure	Fine filters are wet and / or dirty.	Check filters more often Renew them if necessary (white = OK) Brown-black = renewal
Wrong measuring values	Cover, intermediary unit, plexiglass tube and locking pieces are not tightly fixed respectively screwed	Check tightness with every filter change.

**11.8. Further options**

**Prefilter for high dust concentrations**

If necessary, this pre-filter is inserted into the hose line directly after the probe handle.



Filter Tablets:  
 # 52798 50 Filter Tablets

## **12 Declaration of conformity**

