

IMPORTANT
Read Before Using

IMPORTANT
Lire avant usage

IMPORTANTE
Leer antes de usar



Operating / Safety Instructions

Consignes d'utilisation/de sécurité

Instrucciones de funcionamiento y seguridad

3D40
Idea Builder

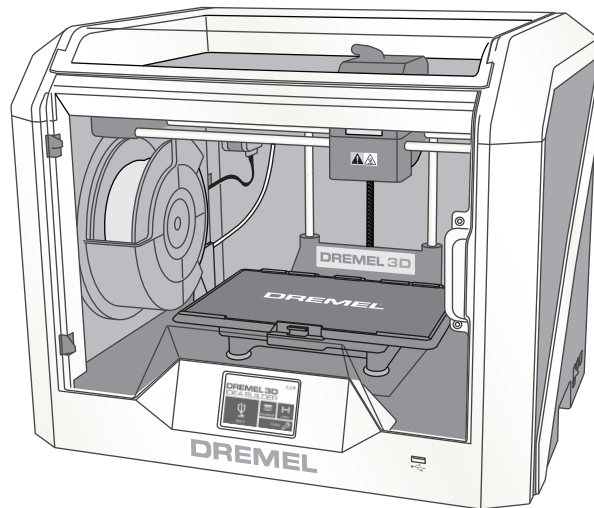

DREMEL®

Call Toll Free for Consumer Information & Service Locations

Pour obtenir des informations et les adresses de nos centres de service après-vente, appelez ce numéro gratuit. Llame gratis para obtener información para el consumidor y ubicaciones de servicio.





For English Version
See page 2

Table of Contents

Safety Symbols.....	2
General Safety Warnings.....	3-5
Additional Safety Warnings.....	5
Symbols.....	5
Dremel Remote and Mobile Services.....	5
FCC Compliance.....	6
Information on Intellectual Property.....	6
Specifications.....	7
Resources.....	8
Glossary of Terms.....	8-9
Introduction.....	10
Kit Contents.....	10
Unpacking.....	11
Getting To Know Your Dremel 3D40.....	12,13
Touch Screen.....	14-20
Initial Setup.....	21
Getting Started with Your Dremel 3D App.....	22
Print Studio Software Overview.....	23
Getting Ready to Build.....	24-28
Building.....	29-30
Removing Your Object.....	31
Maintenance.....	32
Troubleshooting.....	33
Best Practices.....	34
Dremel® Consumer Limited Warranty.....	35

Safety Symbols

The definitions below describe the level of severity for each signal word. Please read the manual and pay attention to these symbols.

	This is the safety alert symbol. It is used to alert you to potential personal injury hazards. Obey all safety messages that follow this symbol to avoid possible injury or death.
 DANGER	DANGER indicates a hazardous situation which, if not avoided, will result in death or serious injury.
 WARNING	WARNING indicates a hazardous situation which, if not avoided, will result in death or serious injury.
 CAUTION	CAUTION, used with the safety alert symbol, indicates a hazardous situation which, if not avoided, will result in minor or moderate injury.

General Safety Warnings

⚠ WARNING Read all instructions in this manual and familiarize yourself with the Dremel 3D40 before setup and use. Failure to comply with the warnings and instructions may result in fire, equipment damage, property damage, or personal injury.

READ ALL INSTRUCTIONS

SAVE ALL WARNINGS AND INSTRUCTIONS FOR FUTURE REFERENCE

Work Area Safety

Keep work area clean and well lit. Cluttered or dark areas invite accidents.

Do not operate Dremel 3D40 in the presence of flammable liquids, gases or dust. Dremel 3D40 creates high temperatures which may ignite the dust or fumes.

Store idle 3D40 out of reach of children and other untrained persons. Injury can occur in hands of untrained users.

Electrical Safety

Always use the Dremel 3D40 with a properly grounded outlet. Do not modify Dremel 3D40 plug. Improper grounding and modified plugs increase risk of electric shock.

Do not use Dremel 3D40 in damp or wet locations. Do not expose Dremel 3D40 to rain. Presence of moisture increases risk of electric shock.

Do not abuse the cord. Never use the cord for pulling or unplugging the Dremel 3D40. Keep cord away from heat, oil, sharp edges or moving parts. Damaged or entangled cords increase the risk of electric shock.

Avoid using this product during an electric storm. There may be a remote risk of a power surge from lightning that may result in electric shock hazard.

In case of emergency unplug Dremel 3D40 from outlet.

Personal Safety

Stay alert, watch what you are doing and use common sense when operating a Dremel 3D40. Do not use Dremel 3D40 while you are tired or under the influence of drugs, alcohol or medication. A moment of inattention while operating Dremel 3D40 may result in personal injury.

Use personal protective equipment. The use of protective equipment such as heat resistant gloves and safety glasses will reduce the risk of personal injuries.

Dress properly. Do not wear loose clothing or jewelry. Keep your hair, clothing and gloves away from moving parts. Loose clothes, jewelry or long hair can be caught in moving parts.

Dremel 3D40 Use and Care

Before every use check Dremel 3D40 for misalignment or binding of moving parts, breakage of parts and any other condition that may affect the Dremel 3D40's operation. If damage is suspected have the Dremel 3D40 repaired by authorized Dremel service center before use. Use of Dremel 3D40 when damaged may result in poor quality of object creation, further equipment damage, property damage or personal injury.

Do not touch the extruder tip during Dremel 3D40 operation or until it has cooled down to at least 60°C (140°F). Contact with the extruder tip during or after operation before tip has cooled may result in personal injury.

Set up the Dremel 3D40 in a well-ventilated area. Place Dremel 3D40 printer on flat nonflammable surface and away from flammable material. Provide at least 8 inches of unobstructed spacing around Dremel 3D40. Dremel 3D40 melts plastic during building. Plastic odors emitted during Dremel 3D40 operation may irritate eyes and airways. Locating Dremel 3D40 close to surrounding objects prevents proper ventilation.

Do not reach inside the Dremel 3D40 while it is in operation. Contact with Dremel 3D40 moving parts during operation may result in poor build quality, equipment damage or personal injury.

Always monitor the Dremel 3D40 during operation. Use of Dremel 3D40 by persons unfamiliar with these warnings and instructions may result in equipment or property damage and personal injury.

Use only DREMEL filament. Use of filament not authorized by Dremel may result in equipment and property damage.

Ensure small objects created by Dremel 3D40 are not accessible to young children. Small objects are potential choking hazards for young children.

Do not create illegal or inappropriate objects using Dremel 3D40.

Do not use Dremel 3D40 to create objects intended for use with candles, liquid fuels, and other heat sources. Plastic may melt when exposed to fire or other heat sources. Such use of objects created by Dremel 3D40 may result in fire, property damage and personal injury.

Do not use Dremel 3D40 to create objects intended for food or drink applications such as preparation, decoration, storage, or consumption. Such use of objects created by Dremel 3D40 may result in illness or personal injury.

Do not use Dremel 3D40 to create objects intended with use with electrical components or housings of electrical components. PLA plastic is not suitable for electrical applications. Such use of objects created by Dremel 3D40 may result in property damage and personal injury.

Do not put plastic objects in or around your mouth. PLA plastic is not suitable for food or drink preparation and food utensils. Such use of objects created by Dremel 3D40 may result in illness or personal injury.

Do not use Dremel 3D40 to create objects intended for chemical storage. PLA plastic is not suitable for chemical storage. Such use of objects created by Dremel 3D40 may result in property damage and personal injury.

Do not modify Dremel 3D40 or alter factory settings. Modifications may result in equipment and property damage, and personal injury.

Do not expose Dremel 3D40 to temperatures exceeding 70°C (158°F). Dremel 3D40 may become damaged. Dremel 3D40 is intended to operate in temperature between 16-29° C (60 - 85° F).

Do not move or bump Dremel 3D40 or the extruder during operation. The object may build incorrectly.

Do not change filament spool unless the building process is completed, stopped, or paused. Changing the filament during

building will cancel the object and may damage the extruder.

Do not pull the filament out. Doing so may damage the extruder.

Use extra care not to damage the extruder tip when clearing debris. Dremel 3D40 will not work properly with damaged extruder tip and will require replacement.

Before every build make sure that the build platform is covered with Dremel specified build tape. Use of improper build tape may result in equipment damage and poor object build quality.

Be aware of your body position when using hand tools to remove objects from the build platform. Sudden tool slip and improper body position during object removal from the build platform may result in personal injury.

Avoid scratching the build platform when removing objects. Scratches in the build platform will result in improper object creation.

Do not drop the build platform. Tempered glass plate may break and result in personal injury.

Do not remove tempered glass plate from plastic holder. Contact with tempered glass plate edge may result in personal injury.

Do not twist or bend the build platform while removing objects. Tempered glass plate may separate from plastic holder and result in personal injury.

Dremel is not responsible for structural integrity or utility of objects created using Dremel 3D40. Structural models created by inexperienced designers may result in property damage and personal injury.

Service

Always unplug Dremel 3D40 from its power before performing any service procedures. Failure to do so may result in personal injury and equipment damage.

Have your Dremel 3D40 serviced only by an authorized Dremel service center using only Dremel replacement parts. This will ensure that proper operation and safety of Dremel 3D40 is maintained.

Use only Dremel approved materials and components. Use of filament or 3D objects other than Dremel® approved filament and genuine Dremel® components may void warranty.



Additional Safety Warnings

⚠ WARNING This product may contain or discharge chemicals known to the State of California to cause cancer and birth defects or other reproductive harm.

SAVE THESE INSTRUCTIONS

Symbols

IMPORTANT: Some of the following symbols may be used on your 3D40. Please study them and learn their meaning. Proper interpretation of these symbols will allow you to operate the tool better and safer.

Symbol	Designation / Explanation
V	Volts (voltage)
A	Amperes (current)
Hz	Hertz (frequency, cycles per second)
∅	Diameter
0	Off position
~	Alternating current (type or a characteristic of current)
	Hot surface hazard symbol. Contact may cause burn. Allow to cool before servicing.
	Alerts user to read manual.
	This symbol designates that this tool is listed by Underwriters Laboratories, to United States and Canadian Standards.

Dremel Remote and Mobile Services

Dremel remote and mobile services provide you with information and services regarding your Dremel 3D products. The type of information provided by Dremel remote and mobile services may change from time to time. All product information and services are provided for your convenience, “As is” and “As Available”.

Dremel does not guarantee that the information or services will be available, accurate, or reliable, or that product information or services will provide safety in your home. You use all

product information, services, and products at your discretion and risk. The product information and services are not intended as a substitute for direct means of obtaining information.

Network connectivity requires an access point and high speed internet connection. Internet service provider charges may apply.

Mobile printing requires a compatible mobile device and data plan. Carrier charges may apply.

FCC and IC Compliance

FCC COMPLIANCE

NOTE: This equipment has been tested and found to comply with the limits for a Class B digital device, pursuant to Part 15 of the FCC Rules. These limits are designed to provide reasonable protection against harmful interference in a residential installation. This equipment generates, uses, and can radiate radio frequency energy and, if not installed and used in accordance with the instructions, may cause harmful interference to radio communications. However, there is no guarantee that interference will not occur in a particular installation. If this equipment does cause harmful interference to radio or television reception, which can be determined by turning the equipment off and on, the user is encouraged to try to correct the interference by one or more of the following measures:

- Reorient or relocate the receiving antenna.
- Increase the separation between the equipment and receiver.
- Connect the equipment into an outlet on a circuit different from that to which the receiver is connected.

- Consult the dealer or an experienced radio/TV technician for help.

Changes and Modifications not expressly approved by the manufacturer or registrant of this equipment can void your authority to operate this equipment under Federal Communications Commission's rules.

INDUSTRY CANADA (IC)

This device complies with Industry Canada's licence-exempt RSSs. Operation is subject to the following two conditions:

- (1) This device may not cause interference; and
- (2) This device must accept any interference, including interference that may cause undesired operation of the device.

The device meets the exemption from the routine evaluation limits in section 2.5 of RSS 102 and compliance with RSS-102 RF exposure, users can obtain Canadian information on RF exposure and compliance.

Information on Intellectual Property

The Dremel 3D40 is intended for 3D printing objects from digital files that you create or own, or have the right to print using the Dremel 3D40. When making objects using the Dremel 3D40, it is your responsibility to ensure that you do not infringe any third party intellectual property rights or violate any applicable laws or regulations, such as U.S. or foreign intellectual property laws.

The Dremel 3D40 may not be used to make objects protected by intellectual property rights owned by third parties without such third parties' permission. Using the Dremel 3D40 to do any of the following may require the permission of third parties: to make a duplicate or facsimile (in whole or in part) of any object not created by you, to make an object from a digital file you do not own, or to make an object from a scan of a physical

object that you did not create. It is your responsibility to obtain such permission. In some cases, you may not be able to obtain such permission. Where such permission cannot be obtained, you should not 3D print such object, or you do so at your own risk. You may not modify, reverse engineer, decompile, or disassemble the Dremel 3D40 or its software or firmware, except as permitted by applicable law.

If you use the Dremel 3D40 in any way other than as recommended and described in these Operating/Safety Instructions, you do so at your own risk. Using the Dremel 3D40 to make objects that infringe any intellectual property rights owned by third parties could result in civil or criminal prosecution and penalties, and you could be liable for money damages, fines, or imprisonment.

Specifications

BUILDING

Extruder: Single extrusion
Extruder temperature: Up to 230°C (397°F)
Operating Interface: 3.5" full color IPS touch screen
Maximum Build Volume: 10" x 6" x 6.7"
(255mm x 155mm x 170mm)
Layer Thickness: 4 mil | 0.004 inches 100 microns | 0.10 mm

color choices
Internal Storage: 4GB
External Storage: USB Flash Drive

WEIGHT & DIMENSIONS

Weight (without spool): 16kg (35lbs)
Dimensions: 20.25" x 16" x 15.9" (515mm x 406mm x 394mm)

FILAMENT

ONLY works with Dremel 1.75mm filament

FILAMENT STORAGE

All polymers degrade with time. Do not unpack until filament is needed. Filament should be stored at room temperature: 16-29° C (60-85° F) and in dry conditions.

SOFTWARE

Dremel 3D40 comes with complimentary Autodesk Print Studio software for Windows and Mac OSX. This application converts your 3D digital files into buildable files.

SUPPORTED OPERATING SYSTEMS

- Apple® Mac® OS® X v10.9 or later (Mavericks)
- Microsoft® Windows® 8.1
- Microsoft® Windows® 7 SP1

MINIMUM SYSTEM SPECIFICATIONS

- CPU: 64-bit processor (32-bit not supported)
- Memory: 3 GB RAM (4 GB or more recommended)
- Disk space: ~2 GB free disk space for installation
- Display card: 1,024 MB GDDR RAM or more. Microsoft® Direct3D® 11 capable graphics card or higher
- Pointing device: Three-button mouse

ELECTRICAL REQUIREMENTS

3D40 input rating: 100-240V, 47-60Hz, 0.8A-1.8A

OPERATING ENVIRONMENT

Room Temperature: 16-29° C (60 - 85° F)
Level workspace
Dry workspace environment

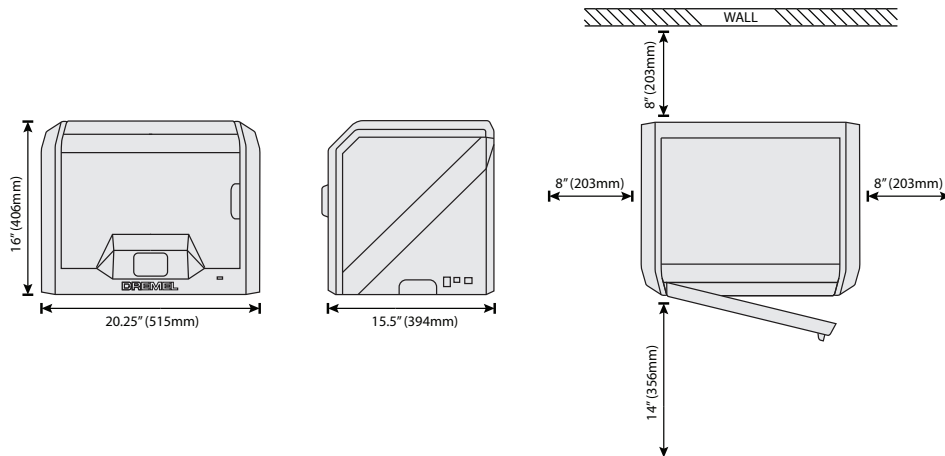

Resources

Resource	Description	Location
Quick Start Guide	Provides illustrated walkthrough of how to un-box your 3D40 and start building out of the box.	
Dremel 3D Website	Provides the latest 3D40 software, product information, customer support, and 3D model and project downloads.	
Dremel 3D Customer Support	Contact Dremel for product support, maintenance, and service.	
Print Studio Software	Allows you to upload, edit, and build 3D files.	

Glossary of Terms

Term	Definition
Build Platform	The flat surface used by your Dremel 3D40 to build objects. The build platform is comprised of a tempered glass plate with a plastic holder.
Build Platform Clip	Clip located at the front of the build platform base that is used to secure the build platform in place.
Build Tape	Adhesive tape that improves the consistency of your objects and helps them stick to the build plate surface.
Build Volume	The three dimensional (3D) amount of space that an object will use once it is completed. Your Dremel 3D40 has a maximum build volume which means that objects with a larger build volume cannot be built unless they are resized or broken into sub-objects.
Door	Your Dremel 3D40 has a door located on the front panel. This allows for easy access to the build platform, extruder, filament, and your objects. This door is made with a transparent material so you can monitor the progress of your objects while keeping the build environment stable.
Ethernet Port	A local area wired networking technology that allow electronic devices to communicate.
Extruder	An assembly that uses gears to pull filament through the extruder intake, heat the filament to the build temperature, and push the heated filament out of the extruder tip.
Extruder Fan	A fan used to cool the outer assembly of the extruder and gear motor.
Extruder Fan Baffle	A plastic piece that directs air from the extruder fan onto the build platform to assist in cooling the active build.
Extruder Intake	An opening located at the top of the extruder where filament is inserted for building.
Extruder Lever	A lever located on the side of the extruder that is used to loosen the grip of the extruder gear motor.

Extruder Tip	A nozzle located at the bottom of the extruder where heated filament is forced out for building.
Filament	A threadlike strand of plastic material.
Filament Guide Tube	A plastic piece that guides the filament from the filament spool through a passage in the outer housing of your Dremel 3D40.
Filament Jam Sensor	A sensor in the extruder that pauses your printer if filament stops extruding properly.
Filament Runout Sensor	A sensor in the extruder intake that pauses your printer if it runs out of filament during a build.
Filament Spool	A cylindrical piece on which a long strand of filament is wound for storage and continuous use.
.G3Drem/.G4Drem	A buildable file format compatible with your Dremel 3D40.
Leveling Knobs	Knobs located under the build platform base that are used to create proper spacing between the extruder tip and the build platform.
Leveling Sensor	A sensor that detects the height of the build platform and assists in proper leveling.
Lid	Your Dremel 3D40 has a pivoting lid on the top. This allows for more access to the build platform, extruder, filament, and objects when necessary.
Needle Nose Pliers	Common tool used to hold small objects and to grab excess material that may be too hot to touch directly.
OBJ File	
Object Removal Tool	A tool used to separate your objects from the build platform.
PLA	A bioplastic derived from renewable resources such as corn starch.
Spool Holder	A plastic piece located to the left of the build platform inside your Dremel 3D40 build area that is designed to hold a filament spool.
Spool Door	A removable door which locks the filament spool to the spool holder.
Stepper Motor	A brushless DC electric motor used to drive the guide rails and extruder gears.
.STL File	
Touch Screen	Full color display that is touch activated. It allows you to monitor your Dremel 3D40 and objects while also providing commands directly to your Dremel 3D40 without the use of a computer.
USB Flash Drive	A portable memory card used on a wide array of devices.
WIFI	A local area wireless networking technology that allow electronic devices to communicate.
X-Axis Guide Rails	A set of rails on either side of the extruder that allow a stepper motor to move the extruder to the left or right side of the build area.
Y-Axis Guide Rails	A set of rails on either side of the build area that allow a stepper motor to move the extruder to the front or back of the build area.
Z-Axis Guide Rails	A set of rails located at the back of the build area that allow a stepper motor to move the build platform up or down.

Introduction

Welcome to the world of Dremel 3D. Our mission is to mentor you through the 3D building process and share best practices for bringing your ideas to life.

3D building is a process that will involve experimentation and persistence. Thankfully, the Dremel experts are here to make your job easier with online tips and live support.

Dremel 3D40 brings new functionality to Dremel3D such as network connectivity and remote printing. To get started with 3D40 follow the initial setup routine on the touch screen to connect and register the printer.

Dremel3D mobile application on your compatible mobile device. Your profile gives you access to high-quality models, support and software downloads, and remote printing services powered by Spark. Once setup and registration is complete you are ready to start building.

Kit Contents*

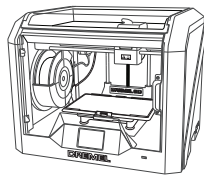

Dremel 3D40



Instruction Manual



Quick Start Guide

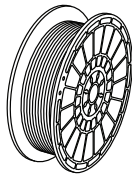

Filament Spool**

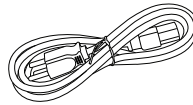

Power Cable

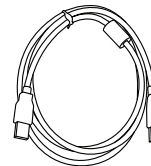

USB Cable



Build Tape

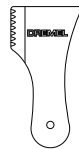

Object Removal Tool

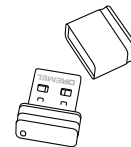

USB Flash Drive

*Quantities may vary depending on kit.

**Do not store in moist or hot environment.



Unclog Tool

Unpacking

1. Place box on table, cut tape, and open.
2. Remove top insert.

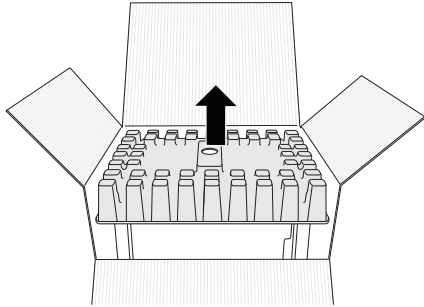

3. Remove 3D40 and place on table.
4. Open lid and remove top insert.

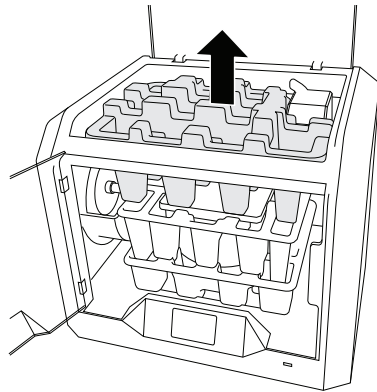

5. Raise build plate by lifting from both sides.

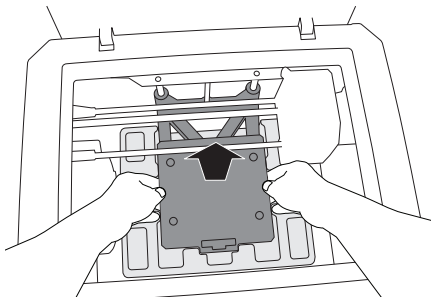

6. Open door and remove middle insert.

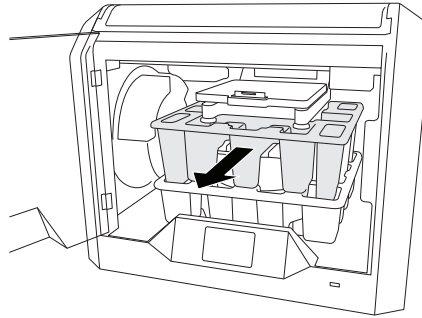

7. Remove bottom insert.

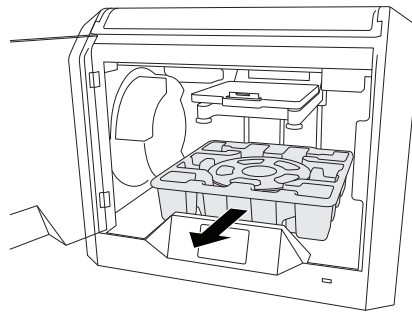

Tip: Keep packaging for future transportation and storage.

Getting To Know Your 3D40

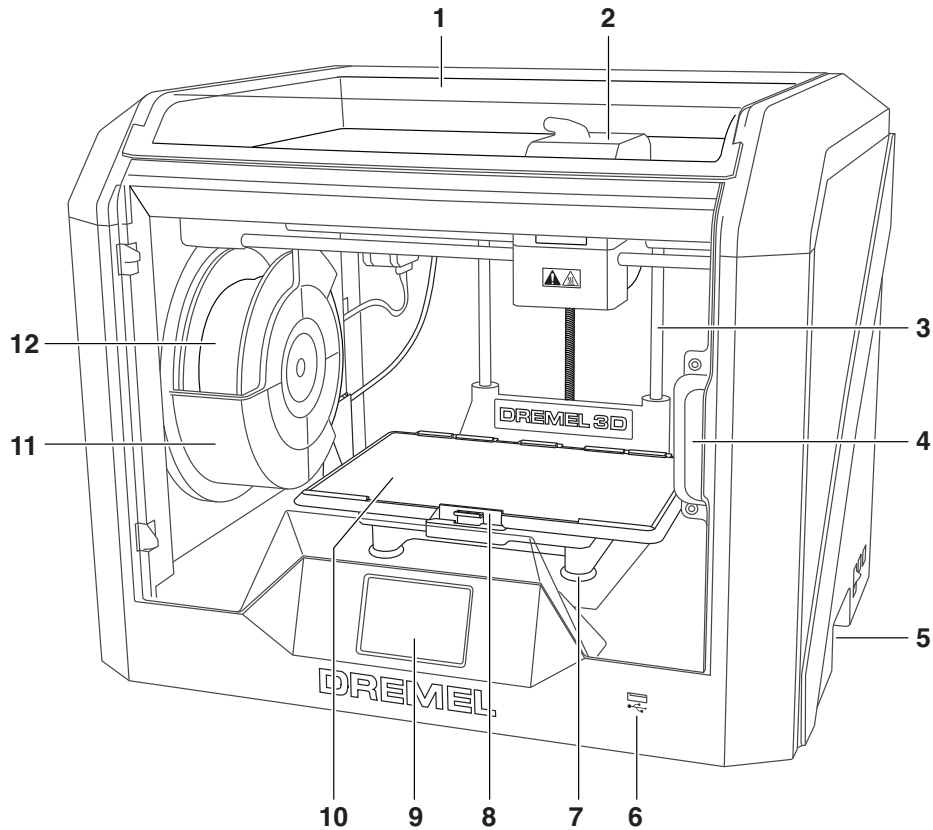

- | | |
|---------------------------|-------------------------|
| 1. Lid | 15. Filament Guide Tube |
| 2. Extruder | 16. Extruder Lever |
| 3. Z-Axis Guide rail | 17. Filament Guide Clip |
| 4. Door | 18. Extruder Intake |
| 5. Gripping Handles | 19. Extruder Fan |
| 6. USB A Port | 20. Ribbon Cable |
| 7. Leveling Knobs | 21. X-Axis Guide Rail |
| 8. Build Platform Clip | 22. Leveling Sensor |
| 9. Touch Screen | 23. Extruder Tip |
| 10. Build Platform | 24. Power Switch |
| 11. Filament Spool Holder | 25. USB B Port |
| 12. Filament Spool | 26. Ethernet Port |
| 13. Y-Axis Guide Rail | 27. Nameplate |
| 14. Stepper motor | 28. Power Input |

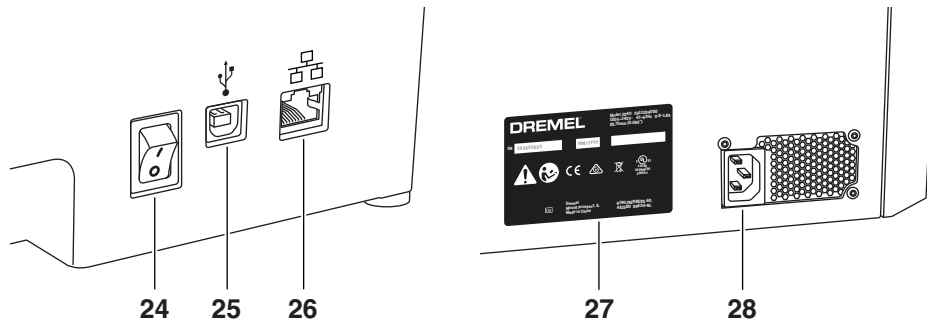
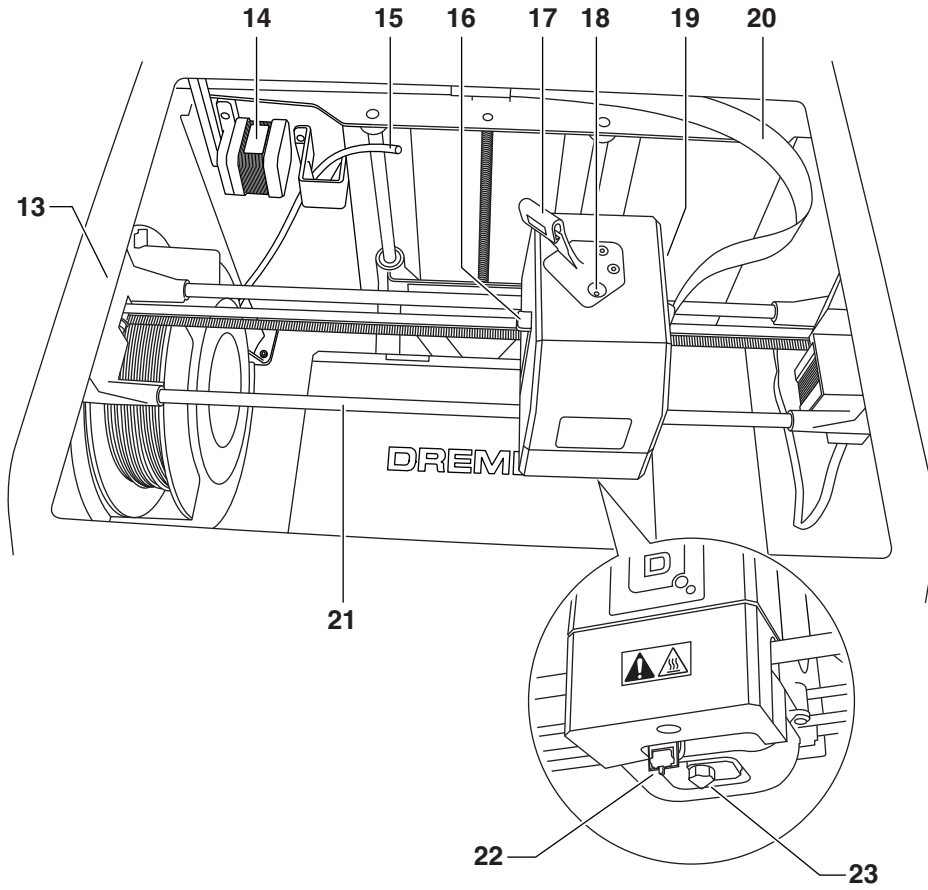



Touch Screen

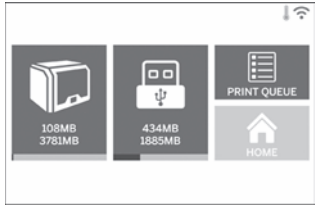

Using your Dremel 3D40 without a computer is easy with the onboard software and full color touch screen.

Before building your model we want to familiarize you with the touch screen menu structure and options.

⚠ WARNING Observe all provided warnings and safety instructions when using the Dremel 3D40. Failure to do so may result in fire, equipment damage, property damage or personal injury.

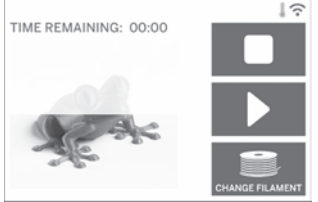
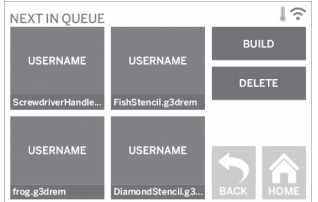
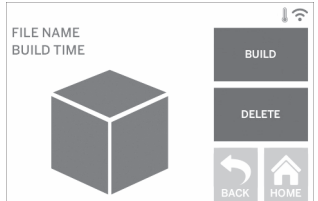
	<p>BUILD</p> <p>Tap to select a 3D model and begin build process. (see page 28 for detailed build instructions)</p>
	<p>BUILD MENU</p> <p>Tap Printer, USB Flash Drive, or Print Queue to choose the destination of your desired file.</p>
	<p>MODEL MENU</p> <p>Tap to select the desired model or use arrows to scroll through pages to find your model.</p>

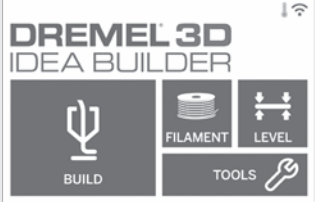
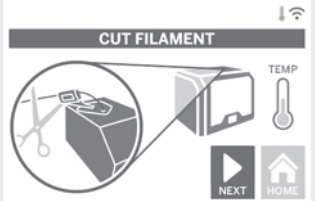
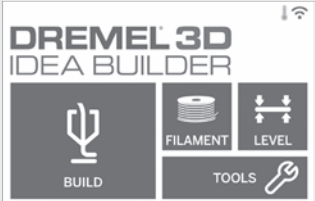
	<p>FILE DETAILS</p> <p>BUILD – Tap to begin build process.</p> <p>DELETE – Tap to remove model file from on-printer storage or USB flash drive.</p> <p>COPY TO PRINTER – From USB flash drive, tap to copy model file to on-printer storage.</p>
	<p>BUILD STATUS</p> <p>STOP – Tap to cancel the current build process.</p> <p>PAUSE/PLAY – Tap to pause or resume the current build process. Pause will allow you to access the filament button.</p> <p>CHANGE FILAMENT – Tap to change filament during the current build process to add more filament or change colors.</p>
	<p>PRINT QUEUE MENU</p> <p>BUILD – Tap to view details of next build.</p> <p>DELETE – Tap to remove next build from queue.</p>
	<p>PRINT QUEUE MODEL DETAILS</p> <p>BUILD – Tap to begin build process.</p> <p>DELETE – Tap to remove model file from queue.</p>

	<p>FILAMENT</p> <p>Tap to begin heating and start filament load/change process. (See page 24 for instructions on filament load/change process)</p>
	
	<p>LEVEL</p> <p>Tap to begin build platform leveling process. (see page 27 for instructions on leveling the build platform)</p>
	



TOOLS

Tap to access the following individual printer functions and settings.



SERVICE

Tap to enter service menu to see customer service contact information.

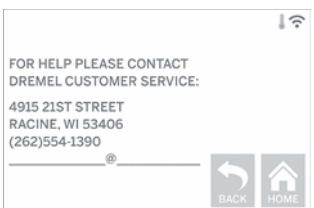
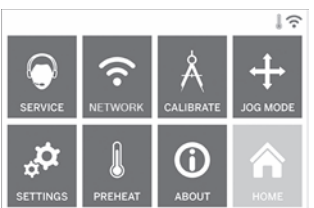
NETWORK

Tap to enter Network menu to connect or disconnect WiFi and Set Proxy.

CONNECT WIFI – Tap to connect to WiFi.

DISCONNECT WIFI – Tap to turn Wifi off.

SET PROXY – Tap to set manual proxy.

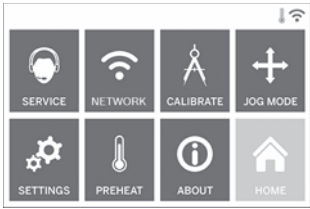
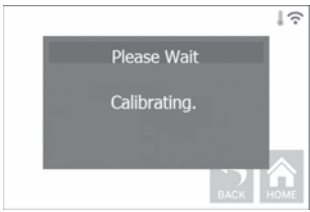

	<p>CALIBRATE</p> <p>Tap to move extruder and build platform to zero position.</p>
	

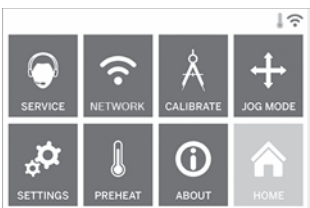
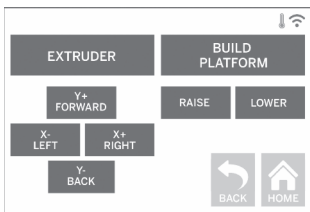

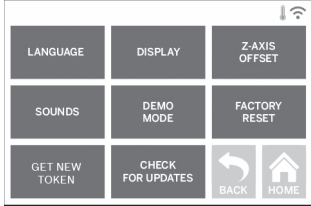

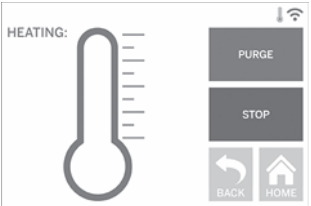

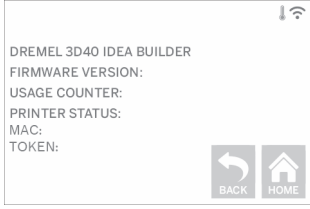
	<p>JOG MODE</p> <p>Tap to display options to move extruder and build platform along the X, Y, and Z-axis.</p>
	

	<p>SETTINGS</p> <p>LANGUAGE – Tap to pick alternate menu language.</p> <p>DISPLAY – Tap to customize cabinet LEDs or main menu hotkeys.</p> <p>Z-AXIS OFFSET – Used to calibrate build plate height during assembly.</p> <p>SOUNDS – Tap to turn 3D40 sounds On/Off.</p> <p>DEMO MODE – Tap to turn retail demo mode On/Off.</p> <p>FACTORY RESET – Tap to remove all information stored on 3D40 and return it to factory defaults.</p> <p>GET NEW TOKEN – Tap to release current token and get a new token when connected to Wifi or Ethernet.</p> <p>CHECK FOR UPDATES – Tap to check for new firmware version when connected to Wifi or Ethernet.</p>
	

	<p>PREHEAT</p> <p>Tap to automatically begin preheating the extruder for building or removing excess debris.</p> <p>PURGE – Once extruder is hot, tap to manually extrude filament.</p> <p>STOP/START – Tap to stop or start preheating.</p>
	

	<p>ABOUT</p> <p>Tap to see 3D40 information such as firmware version, usage counter, printer status, MAC address, and token.</p>
	

Touch Screen Icons

	Indicates that there is an error such as filament empty or door open.
	Indicates that Ethernet is connected.
	Indicates WiFi signal strength and if connected to WiFi symbol will be blue.
	Indicates that the extruder is cool.
	Indicates that the extruder is warm.
	Indicates that the extruder is hot.
	Indicates that the printer is connected to Spark 3D printing services and that it can receive remote commands.

Initial Setup

The first time you power on your Dremel 3D40 you will be prompted to perform an initial setup of network, cloud services, and printer registration. Completing this process will give you access to features such as printing wirelessly from your PC or Dremel3D mobile app, printer sharing amongst your friends and family, notifications of firmware updates, and printer status monitoring.

NOTE: Dremel3D mobile app can be downloaded from the app stores for iOS or Android.

1. To complete initial setup, tap “Yes” when prompted on the initial setup screen. If you decline this setup you can always setup network and register later.



2. If you choose “Yes”, 3D40 will automatically connect to your ethernet (if plugged into router skip to step 5) or search for available wireless networks.

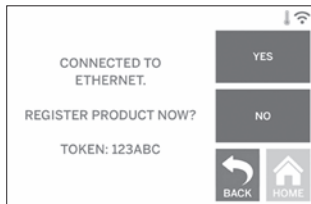

3. Choose your wireless network using the touchscreen. Use the arrows to scroll through the list of available wireless

networks. When your wireless network name is highlighted, tap “Accept”.

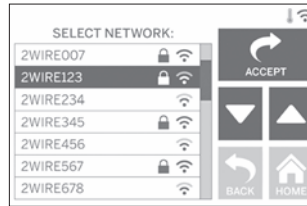

4. Enter your wireless network password and tap “Accept”.

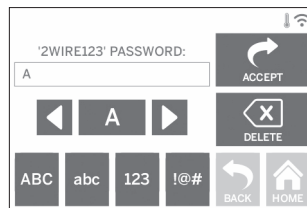

6. Tap “Done” to complete the initial setup process on your printer.

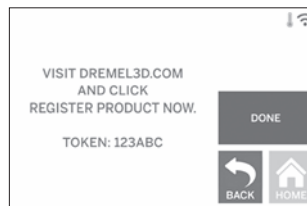

Getting Started with Your Dremel 3D App

The Dremel 3D app allows you to connect to your 3D40 from your mobile device. With the Dremel 3D app you can view models and projects in the Dremel 3D library, send, pause and cancel builds, monitor build status, receive push notification updates, and more. Download the Dremel 3D app from your mobile application store and follow the setup steps below to get started.

1. After installing and launching the Dremel3D app on your mobile device you will need to Log In with your existing Dremel3D user information or Social Log In or Sign Up to create a new account.



4. Mobile functionality on your 3D40 requires connecting to Spark 3D Printing Services, provided by Autodesk®. These services enable your 3D40, mobile device, and Dremel3D profile to be synced. Tap "Connect" to be taken to Spark's site so you can agree to the terms and conditions.

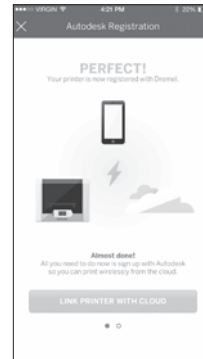

3. Register your 3D40 by filling in the required information and tapping "Register". The serial number of your 3D40 is a 9 digit number that can be found near the power cable, it is important to enter this number exactly as it appears on your 3D40.



5. The last step is to enter the token that was generated by your 3D40 when you connected to Wi Fi or Ethernet. If you did not write this token down it can be found by tapping "Tools", "About". Tap "Done" when the token is entered.

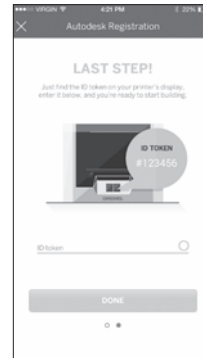

6. Your mobile device is now connected to your 3D40.



Print Studio Software Overview

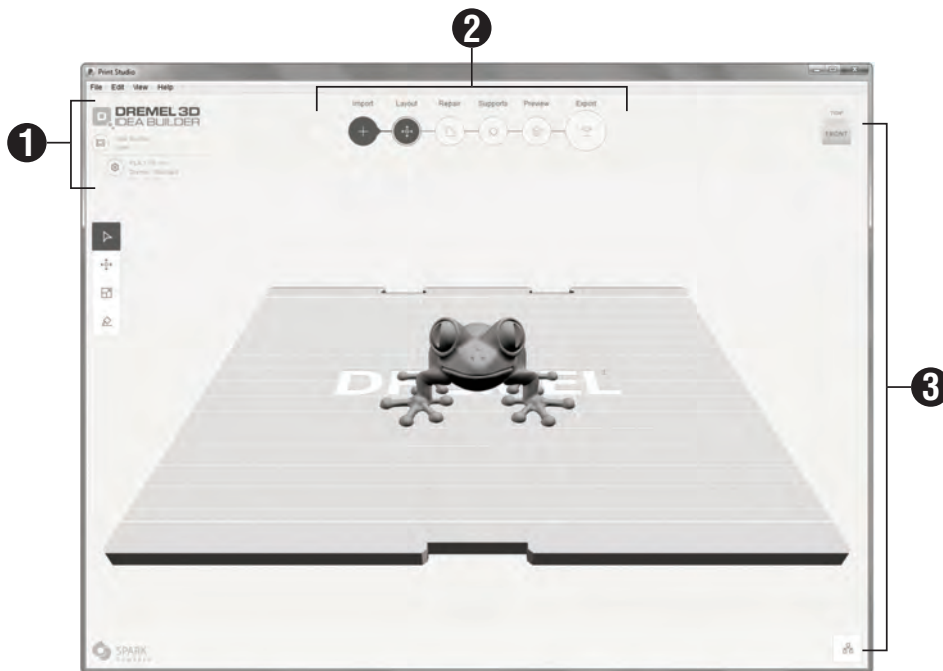

1 SETUP

Printers – Choose your printer type

Settings – Choose your material and build resolution

2 PRINT WORKFLOW

Import – Add models to the build plate from file menu or drag and drop

Layout – Arrange models on the build plate, scale, and rotate

Repair – Automatic repair or manual model healing, crop, plane cut, patch holes, and balancing (manual commands recommended for advanced users)

Supports – Create automatic or manual supports for parts with overhangs

Preview – Create and view the paths that the extruder will follow when building your part

Print / Export – Send your build directly to your Idea Builder when connected via USB cable or save to your computer to load via USB flash drive

3 VIEW

View Cube – Choose the standard orientation that you'd like to view

Object Browser – See a list of all objects on your build plate and turn On/Off automatic supports

Getting Ready to Build

⚠ WARNING Observe all provided warnings and safety instructions when using the Dremel 3D40. Failure to do so may result in fire, equipment damage, property damage or personal injury.

⚠ WARNING Do not touch the extruder tip during operation or until it has cooled down to at least 60°C (140°F). Contact with the extruder tip during or after operation before tip has cooled may result in personal injury.

⚠ WARNING Use only DREMEL filament. Use of filament not authorized by Dremel may result in equipment and property damage.

⚠ CAUTION Do not pull the filament out. Doing so may damage the extruder.

LOADING/CHANGING FILAMENT

1. Start filament load/change process by tapping “Filament” button on touchscreen. Extruder will move to front right corner of print area and extruder tip will begin to heat.

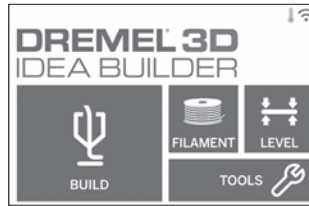

2. After extruder stops moving, open the 3D40 Lid for better access to extruder.
3. If existing filament is loaded, cut existing filament near extruder intake and tap “Next” button on touchscreen.

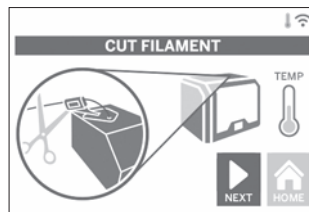

4. Remove Spool door by rotating it counter clockwise and remove existing spool if one is present, see figure 1.

FIG. 1

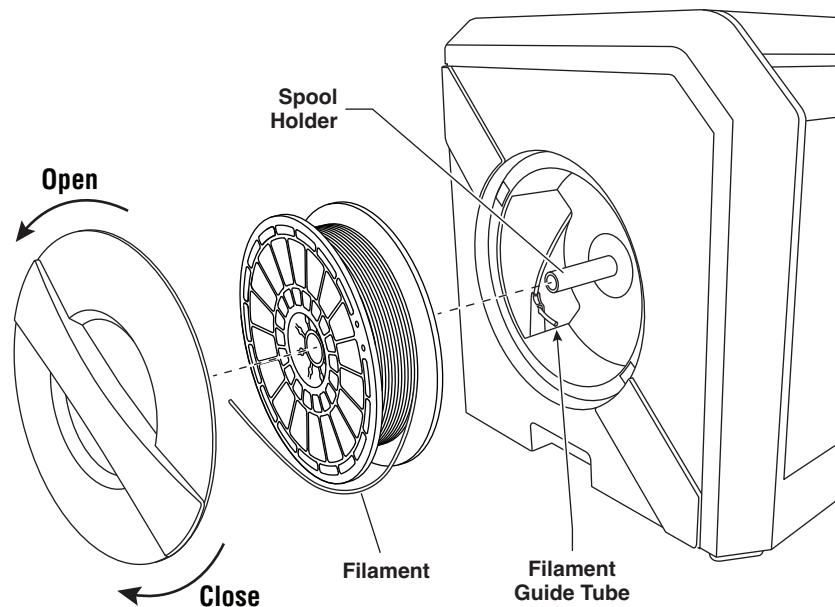
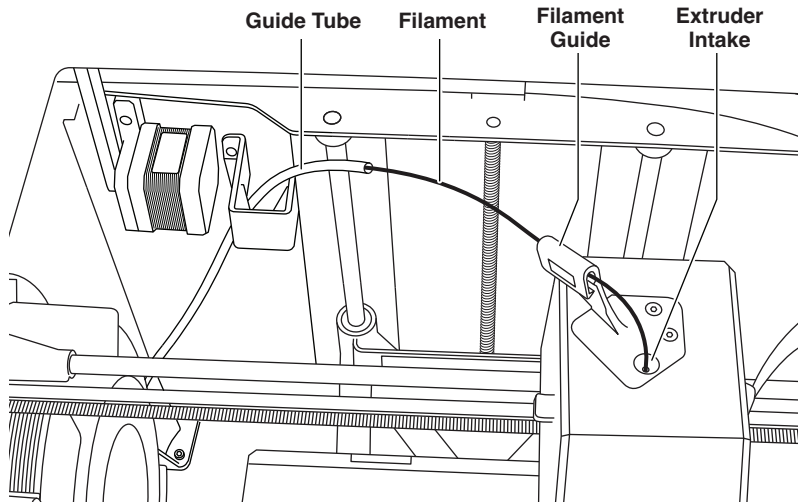
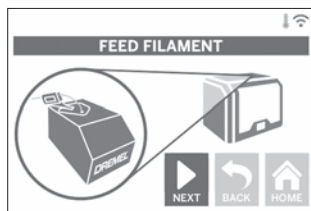

FIG. 2



5. Thread tip of new filament through guide tube, place spool on spool holder, replace spool door by aligning locking tabs and rotating clockwise, see figure 1. Tap “Next” on touchscreen.
6. If changing existing filament, 3D40 will automatically purge existing filament.
7. When Feed Filament screen appears, tap “Next” on touchscreen and thread filament coming from guide tube into extruder intake until extruder feeds through on its own, see figure 2.



8. Filament will be drawn into the extruder and begin to exit from the hot extruder tip.
NOTE: Your Dremel 3D40 was tested by building objects before leaving the factory. These test objects may have

been made with a different filament color than you are using. Therefore, a small amount of filament may be remaining in the extruder.

9. When new filament appears from extruder tip, tap “done” on touchscreen to complete filament load process, return to main menu, and calibrate extruder. Carefully remove excess filament without touching hot extruder tip. If necessary, carefully remove debris from extruder tip with needle nose pliers.

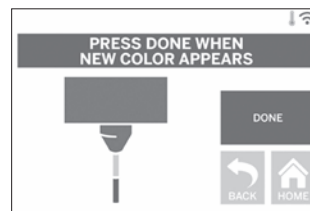

CAUTION Use extra care not to damage the extruder tip when clearing debris. Dremel 3D40 will not work properly with a damaged extruder tip and will require replacement.

10. Close 3D40 lid and door.

PREPARING BUILD PLATFORM

⚠ WARNING Do not drop the build platform. Tempered glass plate may break and result in personal injury.

⚠ WARNING Do not remove tempered glass plate from plastic holder. Contacting with tempered glass plate edge may result in personal injury.

⚠ CAUTION Before every build make sure that the build platform is covered with Dremel specified build tape. Use of improper build tape may result in equipment damage and poor object build quality.

1. If build platform is installed, remove by pinching the clip located at the front of the build platform and lifting the build platform off the base, figure 3.
2. Remove adhesive liner from Build Tape and place Build Tape over Build Platform. For best results, apply Build Tape at center of Build Platform first and smooth outward to remove any air bubbles, figure 4.
3. Install the build platform using the build platform clips.

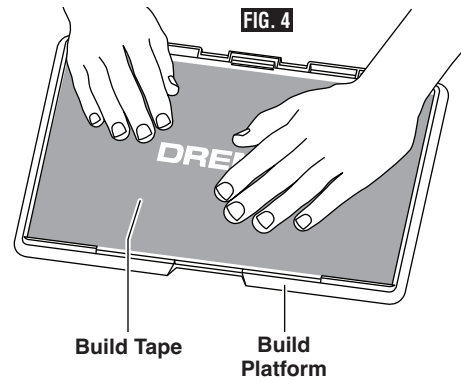
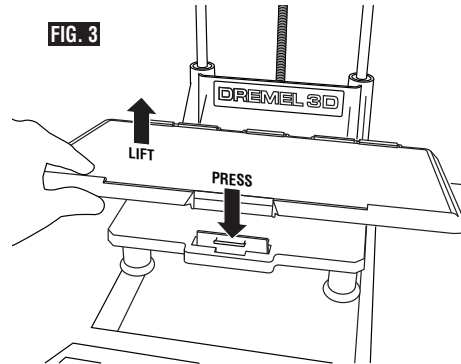

LEVELING BUILD PLATFORM

⚠ WARNING Do not touch the extruder tip during Dremel 3D40 operation or until it has cooled down to 60°C (140°F). Contact with the extruder tip during or after operation before tip has cooled may result in personal injury.

It is important you level the build platform every time you replace the build tape or reinstall the build platform to ensure that the build platform is evenly spaced from the extruder head. Make sure to remove any air bubbles from between the build platform and the build tape. Not leveling the build platform or eliminating air bubbles may cause objects to not build properly.

1. Make sure you have placed Build Tape on Build Platform and no objects are present. Applying Build Tape after leveling may effect the consistency of your object.
2. Tap “Level” on 3D40’s touchscreen.

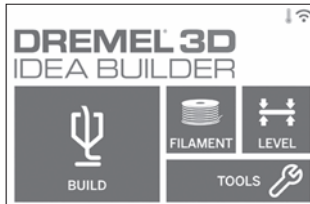

3. The extruder and build platform will move into position to level the build platform. 3D40 will first check level at the back center of the build platform. The two knobs under the build platform are used to raise and lower the build platform on the left and right. The extruder contains a sensor that detects if the bed is level, no additional tools are necessary.
4. The touchscreen will indicate if your build platform is too high or too low. If the build platform is too high, adjust the appropriate knob by rotating right until you hear a “beep” and the touchscreen indicates that it is ready to verify that the bed is level.

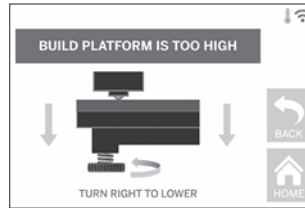

5. If the build platform is too low, adjust the knob by rotating left until you hear a “beep” and the touchscreen indicates that it is ready to verify that the bed is level.

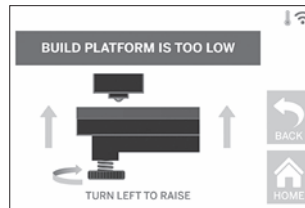

6. Tap “Verify” to check the bed level. If further adjustment is needed the touchscreen will indicate the direction, if the level is correct, the extruder will move to the next point and the level process can be repeated.



7. Repeat steps 4-6 for the second position, when you bed is fully level the extruder will automatically move to the calibration position and complete the leveling process.



CONNECTING USB CABLE

1. Ensure 3D40 power switch is in the off position.
2. Connect the included USB cable to your 3D40 and computer, figure 5.
3. Open software.
4. Turn your Dremel 3D40 on using the power switch to sync your computer to your Dremel 3D40.

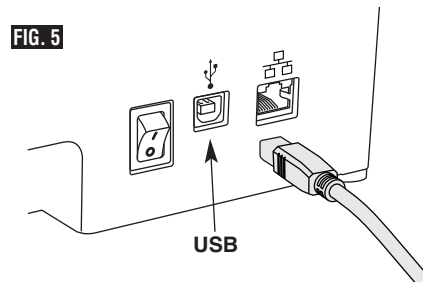

CONNECTING ETHERNET

1. Ensure 3D40 power switch is in the off position.
2. Plug ethernet cable into your 3D40, figure 6.
3. Turn your Dremel 3D40 on using the power switch. Ethernet connection should be detected automatically. Tap "Accept" to confirm connection.

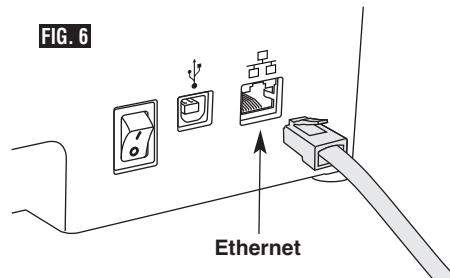

Building

⚠ WARNING Observe all provided warnings and safety instructions when using the Dremel 3D40. Failure to do so may result in fire, equipment damage, property damage or personal injury.

⚠ WARNING Do not reach inside the Dremel 3D40 while it is in operation. Contact with Dremel 3D40 moving parts during operation may result in poor build quality, equipment damage or personal injury.

NOTE: Your Dremel 3D40 will build test objects before leaving the factory. These test objects may have been made with a different filament color than you are using. Therefore,

a small amount of filament may be remaining in the extruder. The start of your first object may have some of this filament color until it transitions over to your filament color.

You have several options when building on your 3D40:

- 1) On-Printer Storage
- 2) USB Flash Drive
- 3) Online Print Queue
- 4) Computer

BEFORE YOU BUILD

1. Ensure an adequate amount of filament is loaded (see page 24).

TIP: You can determine whether you have enough filament to complete your object before building by comparing the length of filament needed as displayed by Print Studio to the length of filament on spool indicated by the length gauge.

If 3D40 runs out of filament during a build, it will pause until more filament is added.

2. Ensure build tape is applied, build platform is level and clear of objects.

BUILDING FROM ON-PRINTER STORAGE

1. On the main menu tap “Build”.

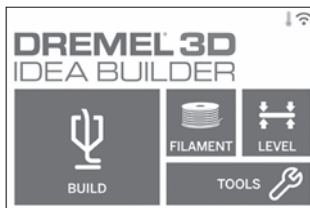

2. On the build menu tap the printer icon.

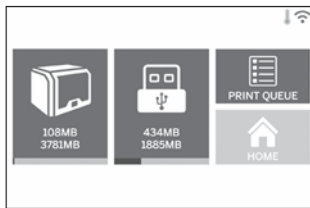

3. Tap the model file you would like to build. (Use arrows to scroll through pages)

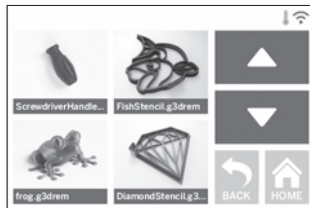

4. In the model detail page tap “Build” to begin building process.



5. Your 3D40 will first align the extruder and build platform to their zero positions then the level sensor will lightly touch the build platform to complete alignment. Your extruder tip will begin to heat which may take a few minutes. Once the proper temperature is reached your model will begin to build.
6. Once your object is finished your 3D40 will automatically align the extruder and build platform to their calibration positions and cool the extruder tip.
7. Wait until the touch screen indicates that the extruder is “cool” to remove your object. See section for removing object from build platform below for object removal instructions.

BUILDING FROM USB FLASH DRIVE

1. On main menu tap “Build”.

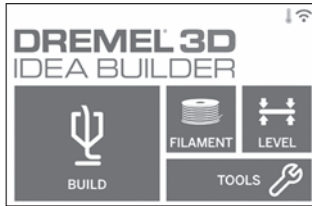

2. Tap USB icon to access contents of USB flash drive.

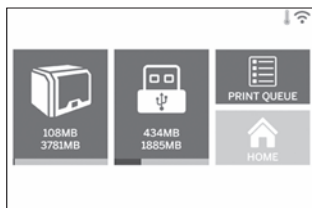

3. Follow steps 3-7 from Build from On-Printer storage to complete build from USB flash drive.

BUILDING FROM PRINT QUEUE

1. If your 3D40 is displaying the Print Queue notification tap “Build” in the notification window to access the Print Queue. If you choose “Decline” you can later access your Print Queue by tapping “Build” then “Print Queue”.

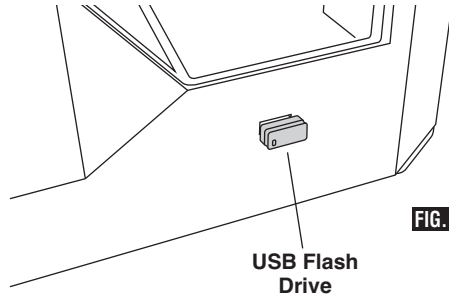
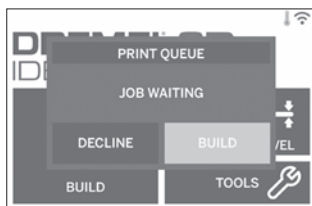
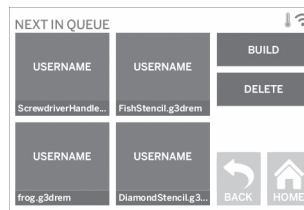
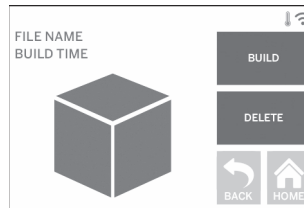

FIG. 7

2. In the Print Queue menu you can choose to “Build” the next model in the queue or “Delete” it and advance to the next model.



3. In Model Details tap “Build” to begin building process or “Delete” to remove the file.



BUILD FROM COMPUTER

Dremel 3D40 is compatible with Print Studio from Autodesk. Follow the instructions that came with this software to complete a Build from your computer.

CANCELING YOUR BUILD ON 3D40

To cancel your object during preheating or building, tap “Stop” on the touch screen. If you confirm “Yes” the extruder and build platform will move to their calibration positions.

Removing Your Object

REMOVING YOUR OBJECT FROM THE BUILD PLATFORM

⚠ WARNING Do not touch the extruder tip during Dremel 3D40 operation or until it has cooled down to at least 60°C (140°F). Contact with the extruder tip during or after operation before tip has cooled may result in personal injury.

⚠ WARNING Use personal protective equipment. The use of protective equipment such as heat resistant gloves and safety glasses will reduce personal injuries.

⚠ WARNING Be aware of your body position when using hand tools to remove objects from the build platform. Sudden tool slip and improper body position during object removal from the build platform may result in personal injury.

⚠ WARNING Do not drop the build platform. Tempered glass plate may break and result in personal injury.

⚠ WARNING Do not twist or bend the build platform while removing objects. Tempered glass plate may separate from plastic holder and result in personal injury.

⚠ CAUTION Avoid scratching the build platform when removing objects. Scratches in the build platform will result in improper object creation.

1. Wait for the extruder to cool before removing your object.
2. With the object still attached, remove build platform from the build area.
3. Peel your object from the build platform. If needed, gently use the object removal tool to remove object from build platform (figure 8). If desired, remove the build tape from the build platform while separating the object from the build platform. The build tape can then be removed from the object.

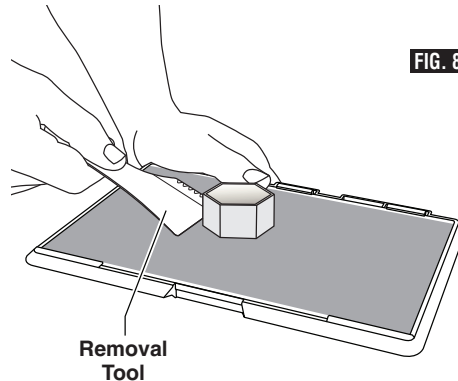

REMOVING SUPPORTS (IF REQUIRED)

Use needle nose pliers to remove supports that are inside your object or hard to reach.

Best Practices

1. ALWAYS USE BUILD TAPE.
2. Ensure your build platform is level before every object.
3. Ensure spool is installed properly and can rotate freely.
4. When using your Dremel 3D40 for the first time or after changing filament, allow Dremel 3D40 to extrude until material is consistent with the installed filament color.
5. It is important to watch your Dremel 3D40 begin building objects. Your object is most likely to experience difficulty in the beginning. Thankfully, this is also the most convenient time to cancel the object, clean the build platform, and start your object again. Remain near the Dremel 3D40 during the building process.
6. It is important to save your Dremel 3D40 packaging as it will make re-boxing and transporting your Dremel 3D40 easier.
7. Ensure that you store filament spools in an environment that is not moist or too hot. It is recommended that you do not remove the filament spool from its airtight packaging until use.
8. Use object removal tool gently to avoid damaging the build platform or object.
9. Whenever possible, it is best to locate your object in the center of the build platform. Using the best orientation for your object is critical. Ensure that your object is located on the build platform and that you are using the best orientation for building.
10. For steep overhangs (Less than 45 degree angle) it is recommended to build with support.
11. Always remove the build platform before removing the object.
12. Low speed sanding is recommended to prevent remelting of the object.
13. The Print Studio software will display the length of filament required for each object. Compare this to the length indicated on the spool length gauge.

Maintenance

UNCLOGGING THE EXTRUDER

Use the unclogging tool to clean the extruder and unclog built up filament, fig 8.

1. Wait for extruder to heat up, insert the unclog tool into the extruder intake (top).
2. Clogged debris will be pushed down and will extrude from the extruder tip.

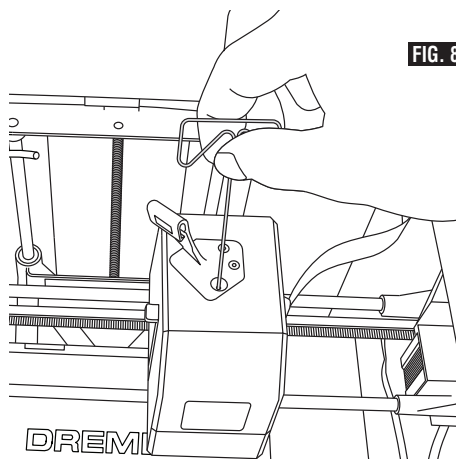

UPDATING FIRMWARE VIA NETWORK

If your 3D40 is registered and added to your Dremel3D profile, you can update its firmware directly from the touchscreen. To update firmware:

1. Tap “Tools”, “Settings”, “Check for Updates”.

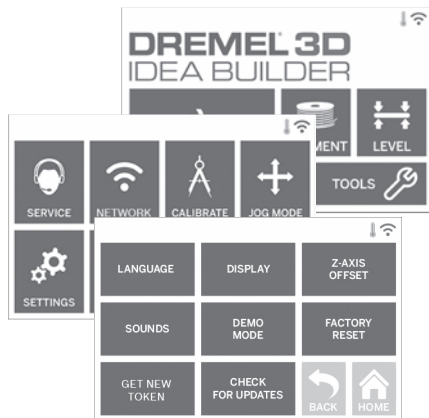

2. Your 3D40 will check to see if it has the latest firmware installed and ask if you would like to update if one is needed.
3. Choose accept to download and install the latest firmware.

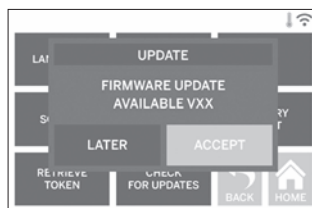

4. When the 3D40 starts up and returns to the Home Screen, firmware update is complete.

UPDATING FIRMWARE MANUALLY

If your 3D40 is not connected to a network, you can update firmware directly from a USB Flashdrive.

2. Add the 3D40 firmware file to an empty, FAT32 formatted, USB flashdrive.
3. Turn off your 3D40 using the ON/OFF switch.
4. Insert the USB flashdrive into the USB-A port.
5. Turn on your 3D40 and it should automatically detect and install the new firmware.
6. Turn your 3D40 OFF, remove the USB flashdrive, and turn ON again to complete the update.

CLEANING THE EXTERIOR

Clean the 3D40’s exterior with a lint free cloth. Clear the outer surfaces of any debris that is visible.

To avoid damaging your Dremel 3D40 do not use water, chemicals or other cleaners on the 3D40.

CLEANING THE EXTRUDER TIP

CAUTION Use extra care not to damage the extruder tip when clearing debris. Dremel 3D40 will not work properly with damaged extruder tip and will require replacement.

WARNING Do not touch the extruder tip during Dremel 3D40 operation or until it has cooled down to 60°C (140°F). Contact with the extruder tip during or after operation before tip has cooled may result in personal injury.

Using small needle nose pliers, pull away any plastic debris from the extruder tip.

If the debris is stubborn, the extruder may need to be heated.

CLEANING THE TOUCH SCREEN

Wipe the touch screen with the soft, lint-free cloth. Do not spray cleaners on the touch screen.

Troubleshooting

PROBLEM	CAUSE	CORRECTIVE ACTION
Extruder head building off center.	Dremel 3D40 has lost track of the extruder head's exact location and is failing to build.	Sending the extruder head to the home position will recalibrate the Dremel 3D40. Cancel your object, clear build platform, send the extruder head to the home position, and restart the object.
PLA is not extruding or sticking to the build tape properly.	This can be caused by the build platform not being leveled with the extruder head.	Leveling the build platform will align the extruder head and ensure a better object quality. Cancel your object, clear build platform, level the build platform, and restart the object.
Print Studio software froze during use or computer froze.	Sometimes software isn't as smart as you are and locks up.	Save any open files if possible and either restart the Print Studio software or your computer.
Dremel 3D40 froze before my object started.	Dremel 3D40 may have received conflicting commands.	Turn power switch off, wait 30 seconds, and turn power switch on.
Support material does not break away during cleaning and results in decreased quality of the final object.	Orientation of the part is not optimized.	Reorient the position of the 3D file in Print Studio to minimize the support material or place the support material on a non-critical surface.
Spaghetti mess at end of build.	A layer of your object did not stick properly, model was saved with minimal surface area contacting the build platform, or object was built floating above the build platform with no support selected.	Use the preview feature in Print Studio to see the first layer height and position. Build with supports when necessary.
Part only built halfway.	Filament ran out. Filament clogged during build.	Replace filament and resume build. See "No filament coming out".
No filament coming out.	Clogged extruder.	Contact customer service.
Extruder will not home.		Contact customer service.
Stringy or fraying plastic layers on steep overhangs.	Object overhangs are too far apart or too steep (<45 degree angle).	Build with supports.
3D40 will not find my Wi-Fi network.	Printer too far from wireless router.	Reposition 3D40 to be closer to your router. Connect to network with Ethernet

PROBLEM	CAUSE	CORRECTIVE ACTION
3D40 will not connect to my network.	Printer too far from wireless router.	Reposition 3D40 to be closer to your router.
	Network password incorrect.	Re-enter your password or verify your password with your network owner.
3D40 will not retrieve a token.	Network password incorrect.	Re-enter your password or verify your password with your network owner.
	Network has a firewall.	Enter network proxy information.
Mobile App will not connect to 3D40 or shows "printer offline".	3D40 not connected to network.	Check 3D40 network settings and retry connection.
Token invalid.	Verify the current 3D40 token using "Tools/About" and retry.	Use "Get new token" to generate a new token and retry connection. Note this will remove any users that are sharing your printer.
Build did not start when sent over network.	Filament ran out.	Load additional filament and resume build.
	Doors open.	Doors must be closed to start builds over your network, start build from print queue.
	Model was already building	The build plate must be clear to start a build over your network, clear the build plate and start build from print queue.

Dremel® Limited Warranty

If used for non-commercial or educational purposes, your Dremel 3D40 is warranted against defective materials or workmanship for a period of one year from the date of purchase. If the Dremel 3D40 is used for commercial purposes, this warranty will apply for 60 days from the date of purchase. In the event of the product fails to conform to this written warranty, please take the following action:

1. DO NOT return your product to the place of purchase.
2. Please contact customer service
3. Carefully package the product by itself, in original packaging, with no other items, and return it, freight prepaid, along with:
 - a. A copy of your dated proof of purchase (please keep a copy for yourself).
 - b. A written statement about the nature of the problem.
 - c. Your name, address and phone number to:

We recommend that the package be insured against loss or in-transit damage, for which we cannot be responsible.

This warranty applies only to the original registered purchaser. DAMAGE TO THE PRODUCT RESULTING FROM TAMPERING, ACCIDENT, ABUSE, NEGLIGENCE, UNAUTHORIZED REPAIRS OR ALTERATIONS, PRODUCT USE IN VIOLATION OF THE "GENERAL SAFETY AND USE WARNINGS," UNAPPROVED ATTACHMENTS OR OTHER CAUSES UNRELATED TO PROBLEMS WITH MATERIAL OR WORKMANSHIP ARE NOT COVERED BY THIS WARRANTY.

No employee, agent, dealer or other person is authorized to give any warranties on behalf of Dremel. If Dremel inspection shows that the problem was caused by problems with material or workmanship within the limitations of the warranty, Dremel will repair or replace the product free of charge and return the product prepaid. Repairs made necessary by normal wear or abuse, or repair for products outside of the warranty period, if they can be made, will be charged at regular factory prices.

DISCLAIMER OF IMPLIED WARRANTIES: DREMEL MAKES NO OTHER WARRANTY OF ANY KIND WHATEVER, EXPRESSED OR IMPLIED, AND ALL IMPLIED WARRANTIES OF MERCHANTABILITY AND FITNESS FOR A PARTICULAR PURPOSE ARE HEREBY DISCLAIMED BY DREMEL AND EXCLUDED FROM THIS LIMITED WARRANTY.

This warranty gives you specific legal rights, and you may also have other rights which vary from state to state. The obligation of the warrantor is solely to repair or replace the product. The warrantor is not liable for any incidental or consequential damages due to any such alleged defect. Some states do not allow the exclusion or limitation of incidental or consequential damages, so the above limitations or exclusion may not apply to you.

For prices and warranty fulfillment in the continental United States, contact a Dremel service location.