



# Light Duty Orbital Shakers



## *Choose the Perfect Light Duty Orbital Shaker You Can Trust for Reliable Everyday Shaking*

Dependable OHAUS Light Duty Shakers are designed for applications with loads up to 4 kg. Choose from two orbits and speed ranges to optimize your sample mix. One digital model dedicated for use with microplates, two digital models designed to work with accessories and a non-digital economical unit for everyday shaking. All models feature triple eccentric drive systems for stable shaking with microprocessor-control for reliable shaking action.

### *Standard Features:*

- Designed for flexibility with your applications – OHAUS Light Duty Shakers include the ready-to-use tray and mat, or remove the mat and customize the tray with over 20 easy-to-install accessories.
- Well-performing economical choice for your everyday laboratory shaking needs. Non-digital model offers reliable shaking across the entire speed range with the robust triple eccentric drive design.
- Microplate shaker is designed to securely hold up to four microplates or deepwell plates, or easily install two microtube racks. Units slowly increase speed to desired setpoint to avoid splashing.

# Light Duty Orbital Shakers

Model	SHLD0415AL	SHLD0403DG	SHLD0415DG	SHLDMP03DG
Control	Analog	Digital		
Motion	Orbital, 0.6 in. / 15 mm	Orbital, 0.1 in. / 3 mm	Orbital, 0.6 in. / 15 mm	Orbital, 0.1 in. / 3 mm
Speed Range	40 to 300 rpm	100 to 1200 rpm	40 to 300 rpm	100 to 1200 rpm
Timer	N/A	1 second to 160 hours		
Capacity	8 lb / 3.6 kg			4 Microplates or 2 Microtube Racks
Working Environment	32 °F – 104 °F / 0 °C to 40 °C, 80% RH, non-condensing	14 °F – 140 °F / -10 °C to 60 °C, 80% RH, non-condensing		
Drive System	Brushless DC Motor; Triple Eccentric			
Tray Size (L × W)	11.75 × 8.75 in. / 299 × 222 mm			11 × 7.75 in. / 279 × 197 mm
Tray Construction	Aluminum			
Dimensions (H × L × W)	4.3 × 16.3 × 10.3 in. / 108 × 413 × 260 mm			
Net Weight	24 lb / 10.9 kg			
Power	120V, 5A, 50/60Hz			
Power Consumption	25 W			

## Other Standard Features and Equipment

Non-slip mat (11.75 × 8.75 in.) included with all models except SHLDMP03DG

## Compliance

- **Product Safety:** CAN/CSA C22.2 61010-1, CAN/CSA C22.2 61010-2-051, UL 61010-1
- **Electromagnetic Compatibility:** ICES-003 Class A, FCC Part 15 Class A
- **Compliance Marks:** TÜV SÜD

## Accessories

Accessories for SHLD0403DG and SHLD0415DG		
Item No.	Description	Max. per Shaker
30400084	Flask Clamp, 10 mL	35
30400085	Flask Clamp, 25 mL	20
30400086	Flask Clamp, 50 mL	15
30400087	Flask Clamp, 125 mL	12
30400088	Flask Clamp, 250 mL	6
30400089	Flask Clamp, 500 mL	4
30400097	Flask Media Bottle Clamp, 500 mL	3
30400099	Flask Clamp PVC 125 mL	12
30400100	Flask Clamp PVC 250 mL	6
30400101	Flask Clamp PVC 500 mL	4
30400114	Microtube Rack (70 tubes per rack)	2
30400115	Tube Rack Ø 10–13 mm (63 tubes per rack)	2
30400116	Tube Rack Ø 14–16 mm (48 tubes per rack)	2
30400117	Tube Rack Ø 18–20 mm (35 tubes per rack)	2
30400118	Tube Rack Ø 22–25 mm (24 tubes per rack)	2
30400119	Tube Rack 15 mL (35 tubes per rack)	2
30400120	Tube Rack 50 mL (12 tubes per rack)	2
30400121	Adjustable Platform, 8.6 × 11.7 in. / 22 × 30 cm, 2 bars	1
30400122	Roller Bar, 8.6 in. / 22 cm (for Adjustable Platform only)	Variable
30400123	Universal Harness	1
30400124	Dimpled Mat, 8.75 × 11.75 in. / 22 × 30 cm	1
30400125	Dilution Cup Tray	1
Accessories for SHLD0415AL		
30400124	Dimpled Mat, 8.75 × 11.75 in. / 22 × 30 cm	1
Accessories for SHLDMP03DG		

## Dimensions

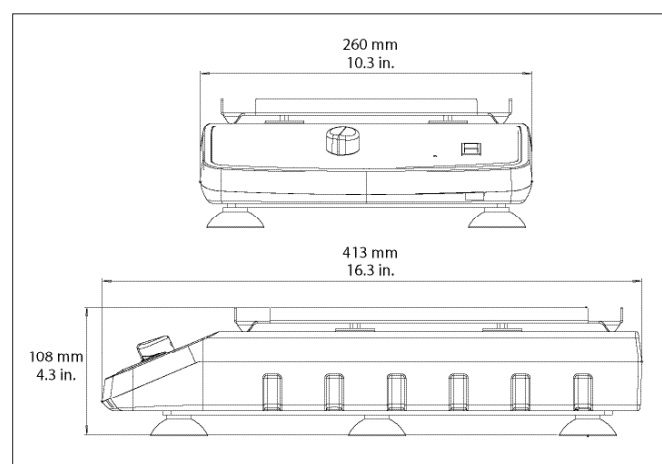

75302\_A 20190502 © Copyright OHAUS Corporation

