

Controller Unit

301C Controller User Manual

M-510324
Revision 04
December 2015

Table of Contents

Notices and Trademarks.....	5
Symbol Definitions	7
Introduction	9
Installation Instructions	10
Surface Mount Installation	11
Wiring Details.....	12
Power Connections.....	13
Communication Connections	13
Settings for Specific Transmitters	14
Relay Output.....	14
Jumper Use Instructions	16
Initial Startup.....	17
Datalogger (SD card).....	17
Programming Interface	18
Keypad Functions	18
LED Definitions	19
System Operation	20
System Programming	21
1. Tx Info Menu.....	25
Ident Menu	26
Product and Sensor Types.....	27
Com Menu.....	28
Scale Menus (1 and 2)	29
Detection Menu	30
Display Menu.....	31
Alarm A, B, and C Menus	32
Servicing and Operating Menus	33
Status Code.....	34
Erase Current Tx	35
Change Tx Address.....	36
2. Groups Menu	37
Creating Groups	38
Deleting Groups	39
3. Events Menu.....	40

continued...

Action Menu	41
Delays Menu	42
Latch Mode.....	43
Conditions	44
Status	49
4. Acqui Menu.....	50
Starting and Stopping Tx Logging	51
Starting and Stopping Event Logging	53
5. Copy Menu	54
Configuration	54
Parameters.....	55
System Log Menu.....	56
6. Config Menu	57
7. Network Menu.....	62
Remote Calibration.....	64
8. Tests Menu	67
Test Sequence	69
Normal Mode.....	71
Single Tx Mode	71
Debug Mode.....	71
Simulation Mode.....	72
9. BACnet Menu	73
BACnet/IP Module.....	73
Device Object.....	77
Base Objects	78
IAQPoint2.....	79
E ³ Point.....	82
XNX and XCD	84
Objects for 301EM.....	85
EC-FX.....	87
420MDBS_IR-F9	88
301ADI	89
301R.....	90
BACnet Protocol Implementation Conformance Statement.....	91
10. Wireless Network.....	95
How To Build a Title 24 Compliant System.....	96
Specifications.....	101
Limited Warranty.....	102

Notices and Trademarks

Copyright by Honeywell International Inc.





While this information is presented in good faith and believed to be accurate, Honeywell disclaims the implied warranties of merchantability for a particular purpose and makes no express warranties except as may be stated in its written agreement with and for its customers.

In no event is Honeywell liable to anyone for any indirect, special or consequential damages. The information and specifications in this document are subject to change without notice.

This manual covers software version 4.002 and optional BACnet module firmware version 1.4.9.

Symbol Definitions

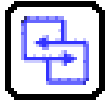
The following table lists the symbols used in this document to denote certain conditions:

Symbol	Definition
	ATTENTION: Identifies information that requires special consideration
	TIP: Identifies advice or hints for the user, often in terms of performing a task
	REFERENCE _ INTERNAL: Identifies an additional source of information within the bookset.
CAUTION	Indicates a situation which, if not avoided, may result in equipment or work (data) on the system being damaged or lost, or may result in the inability to properly operate the process.
	CAUTION: Indicates a potentially hazardous situation which, if not avoided, may result in minor or moderate injury. It may also be used to alert against unsafe practices. CAUTION: Symbol on the equipment refers the user to the product manual for additional information. The symbol appears next to required information in the manual.
	WARNING: Indicates a potentially hazardous situation which, if not avoided, could result in serious injury or death. WARNING symbol on the equipment refers the user to the product manual for additional information. The symbol appears next to required information in the manual.

Introduction

The 301C controller acts as a nerve center for a gas detection network, providing continuous monitoring for up to 96 connected units (plus 1 301ADI). Once installed and connected, the controllers allow the user to monitor, adjust, or reconfigure an entire network of units.

Intended Use

The controller is intended to monitor an entire gas detection network around the clock. The unit offers logging capabilities, creating log files of all transmitter concentrations and alarms for analysis. The unit is also equipped with grouping or zoning capabilities that allow users to query and monitor specific groups of transmitters or specific transmitter zones.

Receiving and Unpacking

Upon receiving the controller unit:

- Check that the package is undamaged
- Carefully open the package.
- Locate the packing slip or purchase order and verify that all items on the order are present and undamaged

Note: If the package or any of its contents are damaged, please refer to the Warranty section at the back of the manual for instructions.

Installation Instructions

Basic Guidelines

For proper operation of the controller, follow the instructions in this manual carefully.

- Locate all units in areas easily accessible for service.
- Avoid locations where instruments are subject to vibrations
- Avoid locating units near sources of electromagnetic interference
- Avoid locating units in areas subject to significant temperature swings

Verify local requirements and existing codes that may impact choice of location.

Surface Mount Installation

It is recommended that controllers be installed 5 feet (1.5 m) above the floor, at approximate eye level.

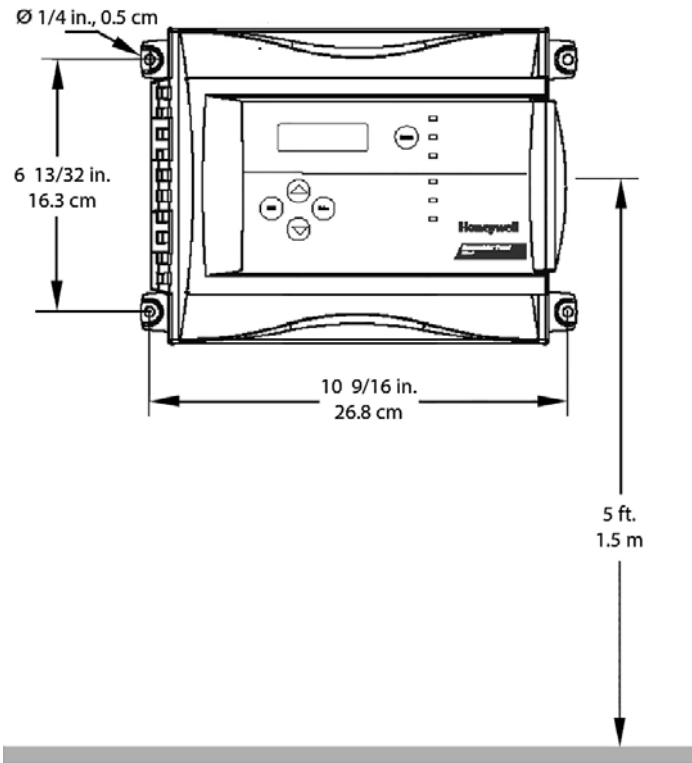

Mark the holes as shown:

- Height markers $6 \frac{13}{32}$ " (16.3 cm) apart
- Width markers $10 \frac{9}{16}$ " (26.8 cm) apart
- Pre-drill $1/4$ " mounting holes as needed
- Securely mount the 301C controller using the appropriate screws

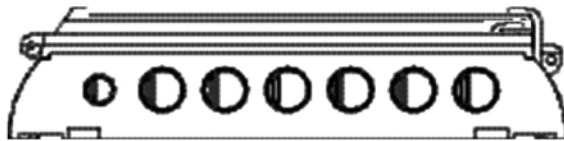

Wiring for the unit must be passed through the knock-outs provided at the bottom of the unit.

Wiring Details

The diagram below provides the details required to connect the 301C controller with power, transmitters, external relay loads, and BACnet. Details concerning power supply, cables, capacities, etc., are provided in the Specifications section at the back of this manual.

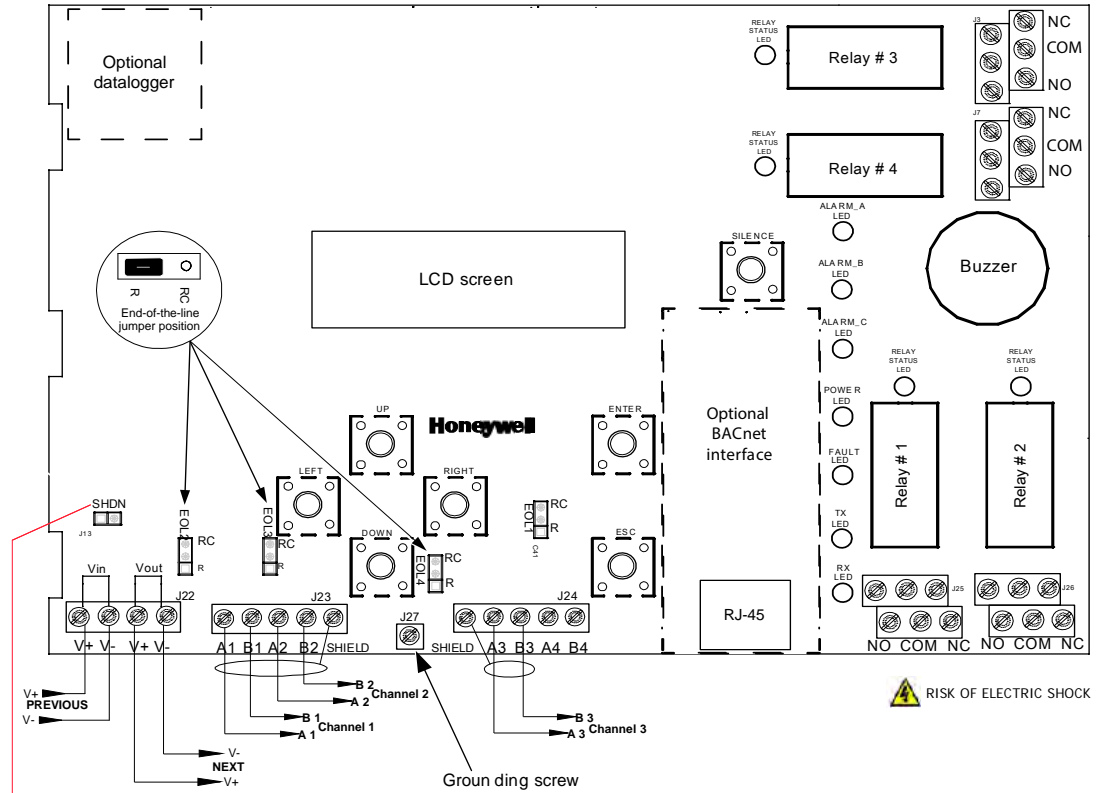

Remove SHDN jumper to enable power

COMMUNICATION
Communication Wire Gauge
 2-24 AWG (Belden 9841)
 Twisted and shielded cable
 2000 feet (600 m) per channel

Channel Specifications:
 Channel 1-2: Modbus, Vulbus protocol
 Channel 3: Modbus protocol
 communicates only with Vulcain transmitters
 Channel 4: not supported

BACnet/IP MODULE (-BIP option)

Ethernet: 10/100-compatible with 10Base-T interface, RJ-45

Visual indicators:
 Green LED = Link connected
 Yellow LED = Active

RELAY OUTPUTS

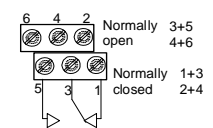

Voltage requirements at device

RISK OF ELECTRIC SHOCK

Topic	Description
J22 Power Input	Connect the power supply to the controller (see Wiring Details for cabling diagrams)
J23, J24 Communication inputs	Connect communication cables to channels 1 through 3.
Relay Outputs 1-4	Depending on the desired configuration, connect the relay cables to either N.O. or N.C. Relays 1 and 2 are commandable by either internal events or by BACnet; relays 3 and 4 are driven only by internal events.
SHDN jumper	Place the jumper over the Shutdown header pins to reset or restart the system.
EOL Resistors 1-4	Place the jumper over the header pins to include resistors to attenuate communication echoes.

Power Connections

The 301C controller requires a power range of 17-27 Vac, 50/60 Hz (8.64 VA), 18-36 Vdc, 350 mA @24 Vdc (8.4 VA). Polarization is not important in either AC or DC mode. The system must be grounded on the transformer and a dedicated circuit breaker must be used.

Communication Connections

Communication cables must be grounded using the shield terminal, using twisted and shielded pair Belden 2-24 AWG #9841 cable (or equivalent).

The network cabling can extend up to 2000 feet (609 m) per channel. Daisy-chain the network cable with no T-taps.

The 301C controller communicates with gas sensors over a Modbus RS-485 network. This transmission line requires that 120Ω termination resistors be fitted at both ends of each network segment to absorb the signal and thus prevent reflections. Fortunately, the controller makes network termination simple as resistors are included on the board. These can be switched in and out of network by moving the “EOL” jumpers as shown in the figure on page 12. More information on RS-485 wiring is published by Maxim Integrated in the [TUTORIAL 763 Guidelines for Proper Wiring of an RS-485 \(TIA/EIA-485-A\) Network](#).

Settings for Specific Transmitters

Honeywell Sensepoint XCD Transmitters must be configured for 9600 baud, no parity, and a unique address. Honeywell XNX Universal Transmitters must be configured for 9600 baud and a unique address. Information on configuring each transmitter is in the associated technical manual.

Some sensors consume multiple addresses on the 301C controller. Specifically, the 301EM consumes 4 addresses regardless of the number of sensors connected. Additionally, the IAQPoint2 consumes 3 addresses if fitted with the optional temperature / humidity sensor. Please allocate proper address spacing for applications utilizing a mixture of sensors on a single system.

Relay Output

The relay output can withstand up to 5A at 30Vdc or 250Vac resistive load. Relays can be used to activate horns and strobes. Although each relay is programmed with a default setting (below), they can be configured using the controller programming menu.

By default, the relays are normally de-energized and will go energized when events occur. However the relays can be configured for “fail-safe” or normally-energized. If so, events will drive them to de-energized.

If relays are set to normally closed, the relay is powered up with the controller and the device linked to the relay is functioning. The relay will shut down when the associated event is activated.

If the relay is set to normally open, the relay will remain off when the controller is powered up and the device connected to the relay will only be activated when the associated event is activated.

Jumper Use Instructions

The jumpers on the controller PCB allow a variety of operations to be performed manually:

Topic	Description		
EOL 1-4	Enables the user to add End-Of-Line jumpers that improve communication signals. Put the jumper in R position (as shown on wiring diagram) to activate the End-of-Line termination. (R provides a resistance termination and RC provides resistance and condensator termination.)		
SHDN	<p>Enables the microcontroller to be reset or temporarily shut down. This function is used mainly when system wiring adjustments are needed (power off for safety).</p> <table border="1" data-bbox="597 1146 1365 1289"> <tr> <td data-bbox="597 1146 777 1289">CAUTION</td> <td data-bbox="777 1146 1365 1289">Power may still be present on the relay terminals even after powering off.</td> </tr> </table>	CAUTION	Power may still be present on the relay terminals even after powering off.
CAUTION	Power may still be present on the relay terminals even after powering off.		
Relays J29-J32	These jumpers allow the relay to be tested by activating it without having any effect on Events.		

Initial Startup

Make sure that all wiring has been completed according to specifications in the wiring details before powering up the unit. When all is secure, remove the SHDN jumper to power-up the unit. Within sixty seconds the controller will be fully operational.

Datalogger (SD card)

The DLC (Data Logger Card) option for the controller collects data and stores it on a digital Flash memory card (SDCard). In the event that the card memory becomes full:

- Information logging is stopped
- No SDcard flag is displayed on-screen
- The SDcard LED blinks

See the Acquisition section for more details on starting and stopping the datalogging function. SDHC cards are not supported; use only SD cards.

CAUTION	Always deactivate datalogging function before removing the SDcard. Never remove the card when its LED is on.
----------------	--

Programming Interface

The front panel of the 301C provides a programming keypad (buttons) and LEDs.

301C controller front panel keypad:

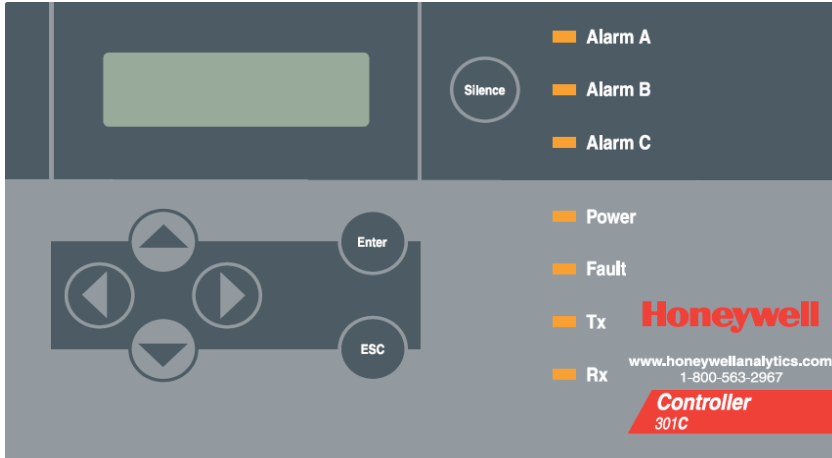

Keypad Functions

Each unit has 7 keypad keys.

The display contrast can be adjusted by pressing the Up and Down keys when the main screen is displayed.

Keys	Description
Arrows	Used to move the cursor through the various programming fields (Up, Down, Left and Right), or to adjust the display contrast (press and hold the up or down arrow until desired contrast is reached and release).
ESC	Used to exit the programming menu or to cancel a change or input.
Enter	Used to access the programming menu and to modify programming fields.
Silence	Turns off the controller's buzzer.

LED Definitions

The controller is equipped with 7 LEDs that provide a status for each function related to that indicator:

LED	Description
Alarm A	A blinking red light indicates that an event has been activated. A constant red light indicates that one or more transmitters have reached Alarm A or Alarm 1.
Alarm B	When the red indicator is on, one or more transmitters have reached Alarm B or Alarm 2.
Alarm C	When the red indicator is on, one or more transmitters have reached Alarm C.
Power	Green indicates that the unit is powered up and functional
Fault	When the amber LED is on, it indicates a fault (i.e. a communication, maintenance or device problem)
Tx	When the amber LED is blinking, it indicates that the controller is <i>sending</i> information or requests on the communication channel.
Rx	When the green LED is blinking, it indicates that the controller is <i>receiving</i> information.

Each of these functions is linked to parameters programmed in the control unit, which we will discuss in the following section.

System Operation

The system operates in four different modes that allow it to use, analyze, debug, and simulate the actions that the system can perform. These modes are: Normal, Single Tx, Debug and Simulate. The default system operation mode is Normal. The other modes are available through the Tests menu (option 8 from the Main Menu).

Note: Systems services may be disrupted by some menu operations. Specifically, viewing the “events” dialogue may inhibit event operation.



System Programming

The system's Normal programming mode offers several menu options that are accessible from the main menu screen:

Mode	Description
1. Tx Info	Allows transmitter parameters to be programmed
2. Groups	Allows sets of multiple transmitters to be aggregated for simpler programming of a common response.
3. Events	Facilitates creation of logical terms which respond to transmitters or events. These Boolean outputs can respond to concentration, alarm, or fault status. These events facilitate voting within a group and can drive relay outputs.
4. Acqui	Allows the datalogging feature to be activated or deactivated
5. Copy	Allows data or parameters to be copied from the (controller) configuration to parameters
6. Config	Allows system parameters and password to be set
7. Network	Allows actions on the network to be performed, communication statistics to be consulted, and remote calibrations to be performed
8. Tests	Allows each device to be tested sequentially (inputs, outputs, communications, events, etc.) and operation of various parameters to be validated
9. BACNet	Allows a device's BACNet parameters to be set
10. Wireless	Not supported.









*Note: Access to the programming functions is password protected.
The default password is 2967.*

The screen display shown below appears initially. This display can be configured to scroll among the information screens for each device connected to the controller.

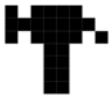
VA301C	Ver. 3.00
Ad: 1	Gr:0
Ev:0	
 	
2007-01-17	13:18:18

If one or more of the connected devices is in an alarm mode, the controller will only scroll between the main information screen and the screens for device(s) in alarm mode. In this case, you must scroll manually to view screens for other devices.

The information screen also displays icons representing certain system functions. Here is a list of possible icons and their meaning:

Icon	Description
	BACNet: Indicates that there is a BACNet module present and that it is communicating with the controller.
	BACNet error: Indicates that a BACNet module is present but communication with the controller has failed (error)
	Debug: Indicates whether the controller is in debug mode (Single TX, Debug or Simulation modes). When in simulation mode, SIM appears next to this icon.
	Log: Indicates that either “Tx Logging” or “Event logging” is enabled.
	Log error: Indicates that an error occurred during TX or Event logging. All logging functions are stopped.
	SDC: Indicates that an SDcard is present and functioning. The icon “fills” (from white to black) progressively as memory is used. A white icon indicates empty memory and black indicates full memory.
	SDC error: If this symbol persists for more than 5 seconds, an SD card card is present but not functioning properly.
	Wireless network: Indicates that the wireless network coordinator (wireless communication module) is present and communicating with the controller.
	Wireless network error: Indicates that the wireless network coordinator (wireless communication module) is present but is not communicating with the controller.

Since the controller's programming functions are password protected, it is necessary to access the login screen:

- Press Enter to access the programming options. The password screen appears:
- Use the keypad Up or Down arrows to increase or decrease the value, one digit at a time, starting with the first digit
- When all the digits of the password are correct, press Enter to access the programming functions.

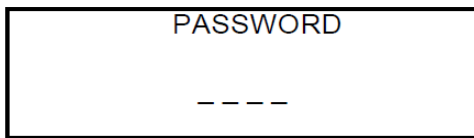

The first MENU options screen appears. Use the keypad arrows to navigate through multiple screens to the desired function and press Enter to access it.

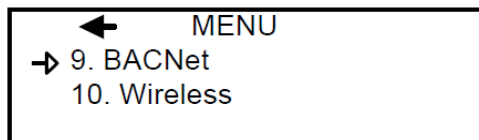
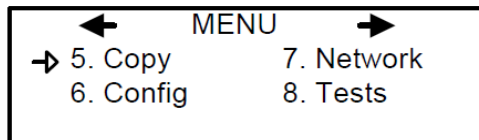
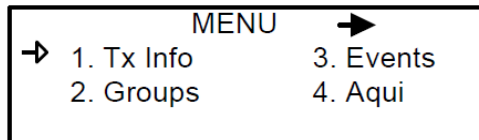

1. Tx Info Menu

Tx Info is the menu option dedicated to transmitter information and several sub-menu options. They are summarized here and detailed on the following pages. Exact screens will vary with transmitter types.

Menu Option	Description	Screen
Ident	Allows the network component's identification information to be viewed.	<pre> 1. Tx INFO 001 -Ident- E3POINT COMB </pre>
COM	Allows the communication protocol to be viewed or changed	<pre> 1. Tx INFO 001 -COM- MdbS RTU 8D 2S NP 9600 bauds </pre>
Detection or Scale (1) and Scale (2)	Allows the detection range and the unit of measurement parameters to be viewed and changed	<pre> 1. Tx INFO 001 -Detection- Scale: 0 - 1.00 Units: % </pre>
		<pre> 1. Tx INFO 001 -Scale(1)- MAX 01000 MIN 00000 </pre>
		<pre> 1. Tx INFO 001 -Scale(2)- Factor 00010 Units % </pre>
Display	Allows the label (or name) of a specific component to be changed	<pre> 1. Tx INFO 001 -Display- edit (20 chard max) E3POINT COMB Ad001 </pre>
Alarms	Allow alarm thresholds to be viewed and sometimes changed. There can be significant variations in this screen depending on transmitter type.	<pre> 1. Tx INFO 001 -Alarm A- MIN MAX 20.0% 25.0% </pre>
		<pre> 1. Tx INFO 001 -Operating Times- Lifetime 0h Since Calib 1234h </pre>
Status Displays	Transmitter and node status (in hexadecimal values)	<pre> 1. Tx INFO 001 -Status Codes- Tx Status 0000h Snsr Status 0000h </pre>
Erase or Current Tx	Erases or changes the Tx address	<pre> 1. Tx INFO 001 Erase current Tx Change Tx address </pre>

Ident Menu

The Ident, or identification menu allows a component's network ID to be consulted:

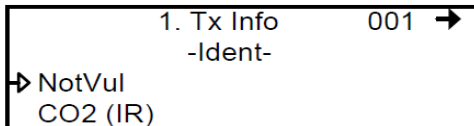

The upper right corner of the screen shows the component's address. If the address of the device whose information must be viewed is known:

- Use the arrows to move the cursor arrow to the on-screen address
- Press Enter (the value can be edited while the number is flashing)
- Use the up or down arrows to increase or decrease the value
- Press Enter again to validate the entry and display the information for the desired device.

The bottom left corner of the display shows the transmitter name (ex.: 301D2 - product name) and the sensor type (ex.: CH4 - methane sensor). These values can also be changed for Group or Vulbus product types. The procedure is identical for both fields:
Programming or changing a product or sensor type

- Use the arrows to move the cursor to the product type field.
- Press Enter to select the field (the value can be modified when flashing)
- Use the arrows to scroll through the list of product types and press Enter when the desired product or sensor appears

Product and Sensor Types

This is a list of all the (preprogrammed) product types available from the Identification option in the Tx Info menu.

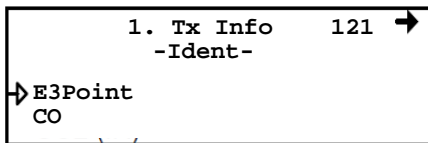

Compatible products:

- E3Point
- 420MDBS
- ECFX
- 301R
- 301EM
- SQN8X
- XCD
- XNX
- IAQPoint2
- Legacy Vulcain products

Note: When Group is selected as a product type, the remaining Tx INFO screens are not accessible (because each product in the group has already been individually programmed). Only the Ident and Erase current Tx screens will be available.

The sensor type list applies to address ranges 1-96 and is not dependent on the type of product selected. Devices in the address range from 97-170 will display a BACNet object identifier, rather than a sensor type.

*An additional Product Type, simply called “Group”, represents a group created in the Groups Menu in the controller. When scrolling through the available product type list, this name will appear as many times as there are groups created in the controller (example: Group 1, Group 2, Group 3, etc.). If a group is selected as the product type, then the sensor type options are limited to MIN, MAX and MEAN.

COM Menu

This screen displays the selected communication protocol for device addresses from 1 to 96. Each transmitter's protocol is defined by the controller (see Network Auto-configuration section)

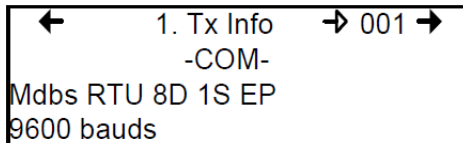

If a transmitter is compatible with several different protocols, it can be modified using to one of the following options:

- Vulbus
- Mdb's ASCII 7D 2S NP 9600 bauds
- Mdb's RTU 8D 2S NP 9600 bauds
- Mdb's RTU 8D 1S NP 9600 bauds
- Mdb's RTU 8D 1S OP 9600 bauds

When a transmitter is configured with the Modbus communication protocol, the transmitters automatically sends the programmable parameters to the controller.

Note: Vulbus transmitter parameters must be programmed manually.

Scale Menus (1 and 2)

These menus appear only for certain devices. Scale(1) allows the detection range, minimum and maximum, to be defined for the selected device. Whatever value is specified is the value that will appear at the device display (if applicable). The Minimum value is generally left at 0. Parameters for the XNX and XCD gas detectors can be viewed here but can be changed only at the transmitter.

←	1. Tx Info	→ 001	→
	-Scale(1)-		
	Max	00250	
	Min	00000	

Scale(2) allows the factor by which to divide the scale (between 0 and 65535) and the unit of measurement for the selected scale to be determined.

←	1. Tx Info	001	→
	-Scale(2)-		
→	Factor	00010	
	Units	%	

The factor allows precise scale limits for detection to be set. By dividing the maximum scale value in the first Scale screen (250 in this example) by 10, a scale value of 25.0 can then be displayed.

The “Units” allow the device’s unit of measurement to be selected:

°F:	Sets degree Farenheit as the unit of measurement
°C	Sets degree Centigrade as the unit of measurement
%RH	Sets Relative Humidity as the unit of measurement
mV	Sets millivolts as the unit of measurement
V	Sets volts as the unit of measurement
mA	Sets milliamps as the unit of measurement
%	Sets the percentage of gas as the point unit of measurement
ppm	Sets parts per million of gas as the point unit of measurement

Detection Menu

The detection menu (available only for devices with addresses between 1 and 96) displays the detection range (scale: 0-100.0) and the unit of measurement (unit: %) for the selected component. If a transmitter uses the Modbus protocol, the detection parameters are automatically defined during network configuration and are not editable. Vulbus protocols must be manually defined by the programmer.

The detection scale is between 0 and the maximum value (0.00) and the unit of measurement is either ppm or percent (% for oxygen and % LEL for combustibles).

The detection menu is not available for the VA301R or VA301AP.

```
←      1. Tx Info      001 →
      -Detection-
→ scale: 0-0.00
   unit: %
```

Programming or modifying the scale range or unit:

- Use the arrows to move the cursor to the scale or unit option
- Press Enter and use the arrow to increase or decrease the value
- Press Enter when the desired value is obtained

Display Menu

This option allows a specific label or name to be assigned to the selected component (transmitters, relay modules, annunciators). Up to 20 characters, including spaces, can be used in the label (example: BOILER ROOM). The default Modbus transmitter labels are composed of the component (or transmitter) name, sensor type and address.

Vulbus transmitter labels contain 20 blank characters (spaces).

←	1. Tx Info	→ 001 →
	-Display-	
edit	(20 char.max)	
301D2	CH4	Ad001

Alarm A, B, and C Menus

The screens for viewing alarm thresholds are combined in this manual. There will be either two or three levels, depending on transmitter type.

If present, separate “MIN” and “MAX” levels permit manual control of the hysteresis of each alarm. Normally, the “MAX” level is set greater than “MIN.” However, alarms can be made to trigger on falling concentration (as with oxygen) by setting the “MAX” threshold smaller than the “MIN” threshold.

With certain transmitters, only one threshold will be displayed.

Additionally, with certain transmitters, the alarm thresholds are read-only at the controller. These thresholds can be set only at the transmitter.

These are typical screens:

```
◀ 1. Tx INFO 001 ▶  
-Alarm B-  
Level  
20.0 ppm
```

Typical screen for viewing alarms A or B on XCD and XNX transmitters

```
◀ 1. Tx INFO 001 ▶  
-Alarm C-  
MIN MAX  
60.0% 65.0%
```

Typical screen for viewing or changing alarm A, B, or C thresholds on other transmitters.

Servicing and Operating Menus

These functions vary depending on the transmitter type. These displays show the total time the device has been in service and the amount of time remaining until the next required calibration or replacement.

```
◀ 1. Tx INFO 001 ▶  
-Operating Times-  
Lifetime 0h  
Since Calib 1234h
```

```
◀ 1. Tx INFO 001 ▶  
-Servicing-  
1234 Hours on  
15514 before cal.
```

```
◀ 1. Tx INFO 001 ▶  
-Operating Times-  
Sensor life left:  
321 days
```

Status Code

These screens display transmission or node status and sensor status for the selected transmitter. This read-only information can assist service personnel in troubleshooting.

The XNX and XCD gas detectors will report the warning or fault number (iFaultWarnNumber) in hexadecimal on the third line. These transmitters will also report the monitoring state (iMonitoringState) in the fourth line. See the transmitter documentation for interpretation of fault numbers and monitoring states.

```
◀ 1. Tx INFO 001 ▶  
-Status Codes-  
Tx Status      0000h  
Monitor State  0001h
```

Typical display for XNX or XCD

```
◀ 1. Tx INFO 001 ▶  
-Status Codes-  
Tx Status      0000h  
Snsr Status    0000h
```

Typical display for other transmitters

Erase Current Tx

This function allows the configuration to be erased or the Tx address for the displayed component to be changed.

Note: *Selecting erase current Tx only erases the current device entry Tx Info configuration. No other data is erased.*

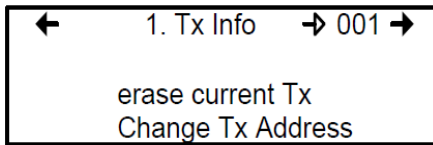

Change Tx Address

Selecting Change Tx Address allows users to move a device from one TX address to another:

- Use the arrows to scroll to Change Tx Address and press Enter to select
- In the next screen, scroll to the address number and press Enter to select
- Use the up or down arrows to increase or decrease the address value and press Enter to validate the new address.

The Change Tx address option is only available (active) for device address 1 to 96 and if there is a Modbus device connected.

If the address is valid, the screen will display “Processing”. If the address is invalid, the screen will display “Invalid Tx” and return to the Change Tx Address screen (the address for GasPoint devices cannot be changed). A final screen will display either “Error” or “Success” (restart procedure if Error is displayed).

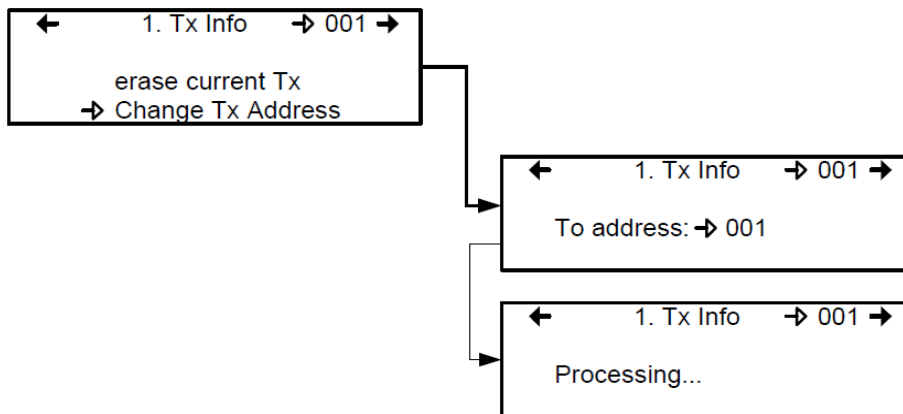

Note: If a device address is changed to one already associated with another device, the existing data will be overwritten. Customers should know their network's address assignments and be careful when changing a Tx address. Delete the original Tx address to avoid duplicate entries. This feature is not supported with XNX and XCD transmitters.

2. Groups Menu

Programming groups of transmitters allows several units to be combined which then enables actions (events) to be taken based on a series of units rather than each unit, individually.

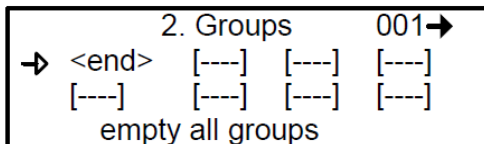
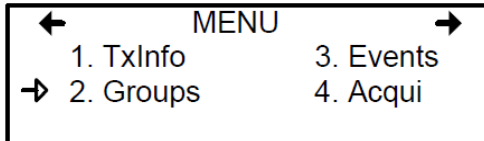

A group is a stack containing the addresses from each of the transmitters included in the group.

Groups are displayed in a single line; if a group contains more than four components, the arrows must be used to scroll left and right of the display window to view all members of a group.

The cursor in the Group screen is represented by the blinking brackets (<end>). Any information between the brackets can be edited.

Creating Groups

The 301C controller accepts a variety of transmitter models with a variety of gas sensors. It can organize the data conveniently using groups and events. However, the group logic requires that all of the members of the group be from the same transmitter models and the same sensor type. Mixing dissimilar sensors or transmitters in a group can cause incorrect results.

- Use the arrows to move the cursor to a group line and press Enter
- The field can be edited when the brackets stop blinking and the word “end” blinks
- Use the up or down arrows to scroll through the list of all units connected to the 301C controller, until the desired address is displayed.
- Press Enter again to validate the address.
- The address is added to the group and the <end> bracket is shifted one position to the right.
- Do not add duplicate copies of a transmitter.

The process can be repeated until all the desired transmitters in the group (up to 126) have been added. The address for each transmitter added in the Tx Info menu is available when creating groups.

Note: Groups created in the Groups menu will appear in the product type list (Tx Info - Ident screen) as “Group xx” (the number assigned to the group when it was created).

Deleting Groups

Use the *empty all groups* command to delete all groups previously programmed in the controller.

Single groups can be deleted with a simple procedure:

- Scroll to the first transmitter in the group list,
- Select the transmitter (its address blinks) and scroll to (erases the entry and <end> marks the end of the stack)
- Press enter and the group is emptied.

This procedure makes it possible to delete one, several or all entries previously included in a group.

Note: *Up to 126 groups, with a maximum of 128 members each, can be created.*

3. Events Menu

The Events menu is programmable. Event programming lets specific actions to be defined:

Menu Topic	Description	Screen
Action	What will be done if programmed criteria are reached	<div style="border: 1px solid black; padding: 5px;"> <p style="text-align: right;">3. Events → 001→</p> <p style="text-align: center;">-Action-</p> <p>Target: Ctrl</p> <p>Relay: #01</p> </div>
Delays	Defines the length of time to wait before taking an action on an event and time to wait after an event has returned to normal before the action output is returned to normal state.	<div style="border: 1px solid black; padding: 5px;"> <p style="text-align: right;">← 3. Events 001→</p> <p style="text-align: center;">-Delays-</p> <p>Before: → 99min</p> <p>After: 01min</p> </div>
Conditions	AND, OR or none (---); equations that allow more detailed control of an event	<div style="border: 1px solid black; padding: 5px;"> <p style="text-align: right;">← 3. Events 001→</p> <p style="text-align: center;">(1/3 Gr036) AND</p> <p style="text-align: center;">= 2.01%</p> </div>
Coverage period	Determines the period during which the event is applicable	<div style="border: 1px solid black; padding: 5px;"> <p style="text-align: right;">← 3. Events → 001→</p> <p style="text-align: center;">-Coverage Period-</p> <p>All day</p> <p>All week</p> </div>
Status disabled	Disables or enables a programmed Event	<div style="border: 1px solid black; padding: 5px;"> <p style="text-align: right;">← 3. EVENEMENT → 001</p> <p style="text-align: center;">-Status : disabled-</p> <p>→ Enable event</p> </div>
Database	Erases the selected event or all events	<div style="border: 1px solid black; padding: 5px;"> <p style="text-align: right;">← 3. Events 001→</p> <p style="text-align: center;">-Database-</p> <p>→ Erase current event</p> <p>Erase all events</p> </div>

Action Menu

Actions are comprised of two parameters:

3. Events	→ 001 →
-Action-	
Target: Ctrl	
Relay: #01	

Parameter	Description
Target	Indicates which component is responsible for the action to be taken; Tx (transmitter) Re (Relay/Annunciator) Ctrl (Controller)
Relay	Indicates which of three possible outputs will be activated when the event is true; #XX (activates the component's #xx relay), Buzzer (activates the component's audible alarm) ALL (activates the relays and audible alarms)

Example: Tx 007 detects a concentration exceeding the set values. The target (controller) triggers relay 1 connected to that event (a fan perhaps). Multiple events may be associated with a single relay. If so, the relay will be activated if any of the associated events are true.

Delays Menu

This option allows Before and After settings that will delay the activation or deactivation of an action to be programmed.

Before Delays the action for the specified length of time. If the condition persists beyond this delay, the defined action is executed.

After The time to wait after an event has returned to normal before returning action output to normal state. The after delay also offers a Latch option, described below.

←	3. Events	001→
	-Delays-	
	Before: →	99min
	After:	01min

Before and After delays can be configured at either 30 or 45 seconds or from 1 to 99 minutes, in one minute increments. Five dashes (-----) indicates that no delay has been programmed.

- Use the keypad arrows to scroll to the desired option
- Press Enter to select the option
- Use the keypad arrows to scroll through the second or minute settings
- Press Enter at the desired setting. The delay is set.

Latch Mode

- The Latch function is executed on an Event state
- It is possible to select the Latch mode by changing the after delay to “latch”
- The Event stays active until the Silence keypad button is pressed
- The Silence keypad button has two functions: Silence the buzzer and unlatch the event.
- When the Silence keypad button is pressed, events in Latch mode are unlatched and reevaluated. If the Event condition persists, the Event remains active and returns to Latch mode. If the condition does not persist, the event is deactivated.

Note: If the Event has a Before delay and the Silence button is pressed while the Event conditions are still true, the buzzer will be silenced only for the length of the programmed delay.

Conditions

Conditions are the parameters that define what makes an Event true. Each condition is defined by four elements and can be combined with other conditions to provide greater flexibility. A condition, as in the example provided below, defines:

IF at least 1/3 of group 36 detects concentrations greater than 2.01% of specified gas AND all of group 03 detects a concentration greater than 2.99% of gas, then the specified action (Actions were set at the first Event screen) for that Event will be triggered.

Since the display screens offer limited space, scroll left and right to view and edit further information.

Condition programming screens

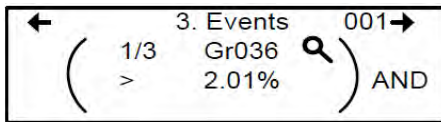

← 3. Events 001 →
(1/3 Gr036 🔍) AND
> 2.01%

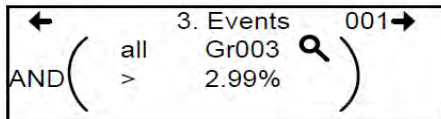

← 3. Events 001 →
AND (all Gr003 🔍)
> 2.99%

The portion of the Events condition screen that is within the brackets is divided into four editable list fields:

The top left portion contains the statistic quantifier (available only for Groups) that take only the specified part of the group into the equation. Options available in this field are:

Option	Description
all	includes all transmitters in the group
mean	includes the average concentration for the group's transmitters
max	includes the group's maximum concentration
min	includes the group's minimum concentration
1/4	includes at least a quarter of the group's transmitters that meets set conditions
1/3	includes at least a third of the group's transmitters that meets set conditions
1/2	includes at least half of the group's transmitters that meets set conditions
2/3	includes at least two thirds of the group's transmitters that meets set conditions
3/4	includes at least three quarters of the group's transmitters that meets set conditions
1 or +	at least one or more than one of the group's transmitters that meets set conditions
outl	The transmitter that deviates the most from the average concentration reading of a group of transmitters is known as an outlier. This quantifier is only available in 301C24 models. Further dialog facilitates specifying the deviation from average required to activate the event and the minimum duration for this deviation. For example, it is possible to set the deviation to 15 ppm and the duration to 30 minutes. This is explained further in <i>How to Build a California Title 24 Compliant System</i> on page 96.

The bottom left portion contains the logic, or operator, quantifier that determines how conditions are calculated. Options available in this field are:

Operator Symbol	Meaning
---	No operator
=	Equal to
<=	Equal to or smaller than
<	Smaller than
>=	Equal to or larger than
>	Larger than
!=	Not equal to
max	When the maximum value is reached, an action is triggered. It will not be deactivated until levels fall below minimum value
min	When concentrations fall below minimum value, an action is triggered. It will not be deactivated until concentrations rise above set maximum value
TSC	The time since calibration reported by the sensor is evaluated. This number is also listed in the "1. TxInfo / Operating Times / Since Calib" menu. Further dialog allows the time limit to be set from 0 minutes to 98 months. This logic function is supported only with E ³ Point transmitters.

The top right portion contains the source, which defines what device or group of devices the Event will be based on. The list provides the following options:

Option	Description
GrAll	Includes all transmitters (see note)
GR ___	Includes only the devices in the specified group (see note)
Tx000	Includes only the specified transmitter (connected to the controller)
Clock	Includes only information gathered between the specified times. Selecting clock sets a condition that is applied only between the start and end time frame. It is possible to set one condition screen to specific parameters and the second to clock, which means that the specified condition will trigger an event only if it occurs during the set time period.

Note: *Clicking on the magnifying glass to the right of a Group number on the display opens a view of the Group for consultation or editing. Press Esc to close the group view and return to the Event condition screen.*

The bottom right portion contains the operand, which defines what device or group of devices on which the Event will be based. The list provides the following options:

Option	Description
OFF	Used for status on binary inputs (ex.: used with 301ADI)
ON	Used for status on binary inputs (ex.: used with 301ADI)
Fault	Bases trigger on maintenance alarm, communication failure or device failure
Alrm A	If the chosen device or group has an Alarm A or Alarm 1, an event will be triggered.
Alrm B	If the chosen device or group has an Alarm B or Alarm 2, an event will be triggered
Alrm C	If the chosen device or group has an Alarm C, an event will be triggered.

The Coverage Period screen allows the period that will be covered by the Event to be defined. (The time frames for each of these periods can be defined in the controller Config menu.) This option provides two further selection fields:

Day definition field: allows All day, Daytime, or Nighttime to be selected

Week definition field: Weekend, Working Days, All week

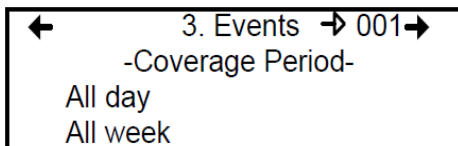

1. Use the keypad up or down arrows to scroll to either All day or All week
2. Press Enter to select. The value can now be changed
3. Use the keypad up or down arrows to scroll through options (see above)
4. Press Enter to select.

Status

This screen displays the current event status and allows it to be either enabled or disabled, depending on the current status.

Enable event: Toggles between Enable and Disable.

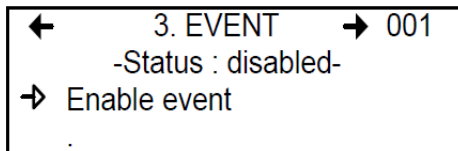

After going through all the steps and programming an event, this screen will display “Enable event”. Press Enter to activate all the parameters and enable the Event.

If an existing Event is being consulted, this screen would display “Disable event”. Press Enter to disable an Event (it will not be deleted but will not function). The programming of this Event is always present, which means that it easily can be reactivated by scrolling to this screen and pressing Enter.

4. Acqui Menu

The Acquisition mode is accessible only when there is an SD card present (controllers with the Data Logging, or DLC function). It is used to enable or disable the logging of system Events or transmitter information. The information is logged (or recorded) on an SD card. Intervals or conditions must be defined before using this option.

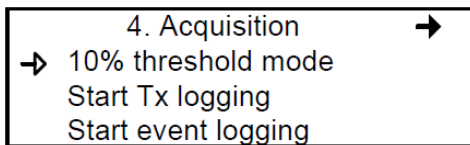

The first line of the Acquisition screen offers either:

First Line	Description
Delay mode	Allows for delay intervals of 10 to 59 seconds or 1 to 60 minutes.
Threshold mode	Allows log values to be set according to set variation thresholds (based on last reading) of 3% or more, 5% or more or 10% or more of last detected concentration.

If a 3% threshold is selected, the system will not log a value at 3% but will log a value of 3.1%. Remember that the sampling rate (system refresh rate) may have an impact on logging.

Here is an example of threshold logging. The logs a semi-colon delineated text files.

```
2005-04-27 11:05:20;1_CO2_ppm;574;-normal-:
2005-04-27 11:06:02;1_CO2_ppm;503;-normal-:
2005-04-27 11:06:15;1_CO2_ppm;562;-normal-:
2005-04-27 11:06:28;1_CO2_ppm;645;-normal-:
2005-04-27 11:06:39;1_CO2_ppm;557;-normal-:
2005-04-27 11:30:45;1_CO2_ppm;715;-normal-:
```

Starting and Stopping Tx Logging

In the previous step, “Acquisition”, the frequency at which Tx logs would be recorded can be configured. To start the logging function:

When “Start Tx logging” appears on the display, it indicates that the acquisition, or logging, mode is inactive. When “Stop Tx logging” appears, it indicates that Tx data is being logged. The log message is displayed on the screen according to the chosen mode and LED 1 will light up.

Press the Enter keypad button to stop or start Tx logging.

When Tx data is logged, the system creates files named **tayymmdd.log**, **tbyymmdd.log** and **tcyymmdd.log**, each representing one third of the network. The record includes the transmitter’s date, time and address, the sensor type, the concentration read, as well as the alarm status. Here is a sample of what a Tx log looks like:

```
2004-01-23 17:54:25; 001_CO_ppm;0;-normal-;002_NO2_ppm;1.5;-normal-;003_CO_ppm;0;-normal-
2004-01-23 17:55:25; 001_CO_ppm;0;-normal-;002_NO2_ppm;0.5;-normal-;003_CO_ppm;0;-normal-
2004-01-23 17:56:25; 001_CO_ppm;0;-normal-;002_NO2_ppm;0.5;-normal-;003_CO_ppm;0;-normal-
2004-01-23 17:57:25; 001_CO_ppm;0;-normal-;002_NO2_ppm;1.0;-normal-;003_CO_ppm;0;-normal-
2004-01-23 17:58:25; 001_CO_ppm;0;-normal-;002_NO2_ppm;1.5;-normal-;003_CO_ppm;0;-normal-
```

These log files are delimited by semicolons and are thus easily read by popular spreadsheet programs such as Microsoft Excel. The first column of the Tx log displays the date (yyyy-mm-dd) and the time (hh:mm:ss) of the log. In this example, the “Delay mode” was set to one minute intervals.

The third column of the Tx log displays the transmitter address and the fourth displays the gas type, gas concentration and unit of measurement.

The display then lists the next transmitter address with its gas type, concentration and unit of measurement, and so on until all the transmitters have been listed.

Starting and Stopping Event Logging

The Acquisition menu offers an event logging option. Event Logging records controller transactions, events, Tx and alarm flags and relay status.

When “Start Event logging” appears on the display, it indicates that the acquisition, or logging, mode is inactive. When “Stop Event logging” appears, it indicates that Event data is being logged.

Press the Enter keypad button to stop or start Event logging.

When Event data is logged, the system creates a file named **evyymmdd.log**. The record includes the date, time and the event. Here is a sample of what an Event log looks like:

```
2004-01-23 17:54:25: Event logging enable
2004-01-23 17:55:25: Event logging enabled
2004-01-23 19:05:47; Simulation sequence activated
2004-01-23 19:05:48; Tx 6 communication no more in fault
2004-01-23 19:05:48; Tx 8 communication no more in fault
```

The first column of the Event log displays the date (yyyy-mm-dd) and time (hh:mm:ss) of the log. Column A displays the date and time of the log. In this example, the event’s “Delay mode” was set to one minute intervals.

The system logs the following types of events:

- Event Log
- Event status changed
- Alarm A, B, C, Fault, and X status changed

Note: New log files are created when the existing files reach 32 000 lines or at the start of a new week (0h00 Sunday)

5. Copy Menu

The Copy menu allows programmed parameters to be copied and transferred. Data from the SD card can be transferred to a controller or from a controller to the SD card or copy parameters from one device to the next. The Copy option offers three screens: Configuration, Parameters and System Log.

Configuration

If the controller is equipped with an SD card, the configuration function allows data to be transferred either from the 301C controller to the SD card or the reverse. This makes it possible to transfer the controller's programming to a computer or from a computer to the controller.

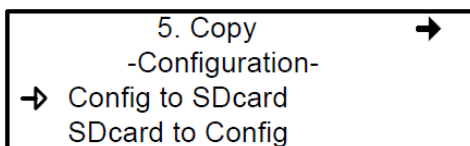

The first option in the configuration screen is 301C controller to SDcard. Selecting this option copies the controller's configuration and parameters into a "config.ini" file¹.

Note: The second option is SDcard to 301C controller allows the configuration and parameters of the "config.ini" file on an SDcard to be copied to the controller. Power must be cycled to fully implement the SD card's configuration by stowing the jumper on the SHDN pin (see the illustration on page 12.) The "config.ini" file contents can be modified at any time and from any computer.

¹When transferring data, the system will automatically search for an existing "config.ini" file before proceeding. If one exists, the system searches for a "config.bak" file. If found, the file is deleted. Then, the pre-existing "config.ini" file is renamed "config.bak", making it possible to save the new "config.ini" file and keep a backup copy of the previous one.

After inserting an SD card into the controller, the controller's system looks for an existing "config.ini" file that contains an "autoload" tag equal to 1 (yes). If the tag is found, the system loads the contents of the file and resets "autoload" to 0 (no). This is a useful feature for editing the file on a computer without having any impact on the controller (such as recorded Events).

Parameters

The “parameters” function allows one transmitter’s configuration to be copied to another or one event’s parameters to be copied to another event. This allows several devices that share identical or similar parameters to be quickly configured.

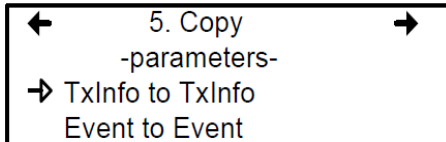

The options within this screen are:

Tx Info to Tx Info copies transmitter parameters from one device to another.

Event to Event copies parameters from Event to Event.

The process is identical for both options:

- Select source, (the data to be copied) using the up/down keypad arrows and press Enter.
- When the transmitter address is flashing, use the up/down keypad buttons to search for the desired device address.
- Press Enter to select the new address
- Select the target address (where the data is to be copied to) in exactly the same way as source
- Select COPY and press Enter. The parameters have been copied.

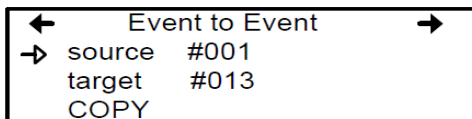
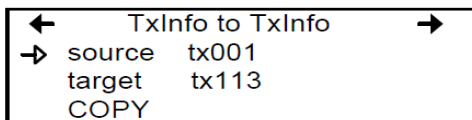

System Log Menu

The controller will record log information to its internal memory. If the controller is equipped with an SD card, the system log function allows users to save system log information to the memory card in text format.

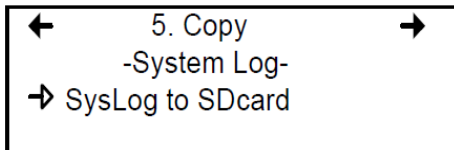

When this option is selected, a log of all the last actions performed on the controller is copied to the SDcard, with the filename **slyymmdd.log**. This file can contain up to a maximum of 64Kb of information in text format. Once the memory card is full, the oldest log entries are erased and replaced by new entries.

Here is an example of a system log:

```
--- START of system log dump : 2007-04-18 13:19:05 ---  
2007-04-04 18:42:06;Accessing menu;  
2007-04-04 18:43:47;Event 1 definition modified;  
2007-04-04 18:48:12;Exiting menu;  
2007-04-04 18:54:49;System power-down;  
2007-04-04 18:56:40;System power-up;  
2007-04-04 19:02:44;Accessing menu;  
2007-04-04 19:03:07;Event 6 definition modified;  
2007-04-04 19:03:21;Exiting menu;  
2007-04-05 10:51:28;Accessing menu;  
2007-04-05 10:54:59;Database reset;  
2007-04-05 10:55:18;Tx 25 parameters modified;  
2007-04-05 10:55:29;Group 0 definition modified;  
2007-04-05 10:55:36;Group 0 definition modified;  
2007-04-05 10:55:46;Group 0 definition modified;  
2007-04-05 10:55:55;Group 4 definition modified;  
2007-04-05 10:55:57;Exiting menu;  
2007-04-05 10:56:02;Accessing menu;  
2007-04-05 10:56:19;Tx 24 parameters modified;
```

6. Config Menu

The Config menu contains several main configuration screens and is used to program the controller display mode, adjust the date and time, select the display language, change the controller access password, set the Relay Configuration, and select the AP Broadcast mode.

Each main screen offers further programming options, as shown.

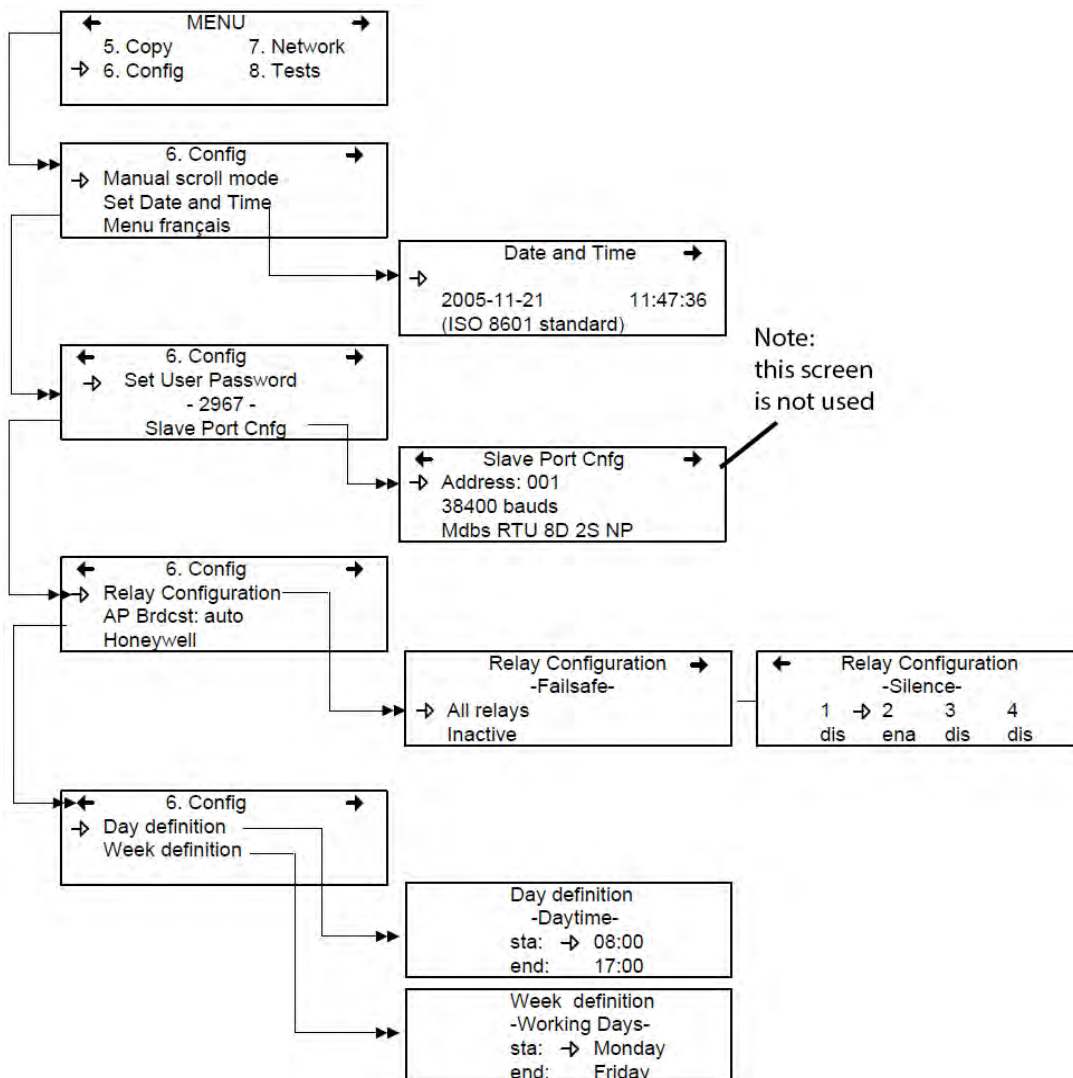

Selecting the first line of the first screen allows selection from three display modes: Manual scroll, 3-second scroll, 5-second scroll. If Manual scroll mode is chosen, the screen will only advance if you press on the arrow keypad buttons. If either 3 or 5 second scroll mode is chosen, the screens will automatically scroll display readings for all devices connected to the controller after 3 or 5 seconds.

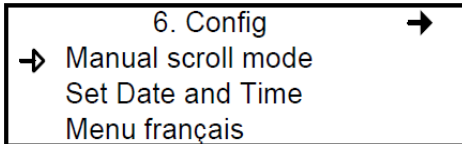

3 or 5 second scroll modes do not prevent the keypad arrows to be used to return to a previous screen or move ahead through the screens manually.

Selecting the second line allows the date and time in a new screen to be adjusted; Date and Time. When a number is flashing, the value can be changed using the up/down keypad arrows. The year, month, day and the hour, minute and second values can be changed.

The controller does not manage Daylight Savings Time, therefore, users must manually adjust any time changes.

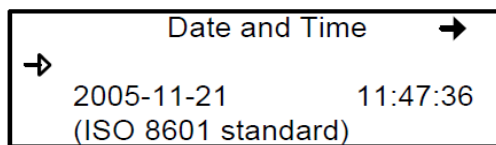

Selecting the third line allows the display language to be changed. If the display is already in English, it will then display the Menu français option (and vice-versa). Simply scroll to the line and press Enter to change the language.

The second main screen in the Config menu allows a new user password to be set.

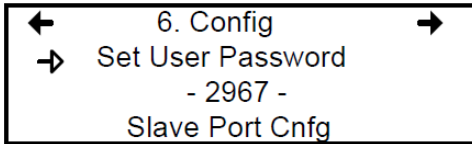

The default password is 2967. Select Set User Password to change the password:

- When the first digit blinks, change the value by using the up/down keypad arrows to increase or decrease the number
- Use the left/right keypad arrows to move from one digit to the next.
- When the desired e has been set, press Enter to validate it and exit the editing mode.

The slave port is not used.

Scroll through the main Config menu screens using the left (previous) or right (next) keypad arrows.

The third main screen in the Config menu allows the relay configuration to be set, the AP broadcast mode and to select from four separate manufacturers for the given controller.

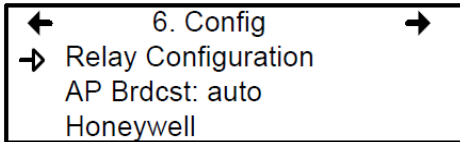

When *Relay Configuration* is selected, two further options to configure the relays are available: The first screen, *Failsafe*, appears allowing the failsafe to be activated for all relays using the Enter keypad button. This function inverts relay operation to be normally energized. If power is cut, the relay will activate the connected device. (ex. a light.)

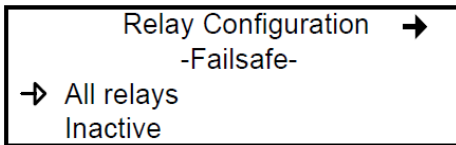

Scrolling to the right displays the "Silence" screen that enables or disables the silence option for each relay, using the Enter keypad button.

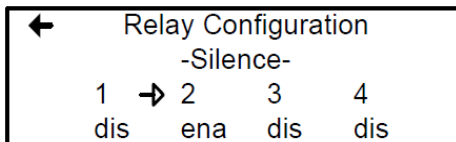

The fourth screen in the Config menu allows a definition of a day and a week to be programmed.

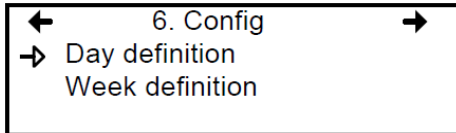

Day and Week definition allows hours (time frames) to be defined for either Daytime and Working Days respectively.

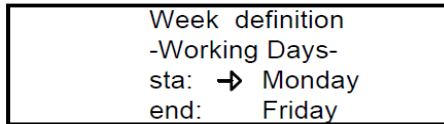
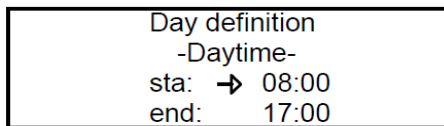

Note: Remember, the controller uses a 24 hour clock (0:00 to 23:59). Any time changes (e.g., for Daylight Savings Time) must be made manually or through BACNet time synchronization (BACNet module required).

7. Network Menu

The Modbus network menu allows network device information to be either scanned or reset.

This menu offers four options, divided into two screens; the first screen contains three options:

Option	Description
Reset Database	Resets all network device Tx information in the database. This only resets the Tx information for the network device. It does not affect programmed Groups or Events.
Network Scan	Begins an auto-detect of all network devices that allows the system to configure the Tx database for network devices (i.e. it will scan and add new devices but will not overwrite or erase the old database). This process takes approximately one minute.
Reset and Scan	Performs both previous functions simultaneously.

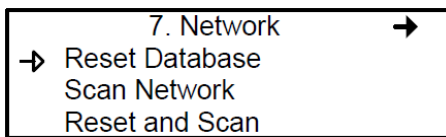

Note: Once one of these options has been set, wait until the controller completes the process. Do not interrupt or stop the process once it has begun.

The second Network screen offers the Statistics and Calibration options.

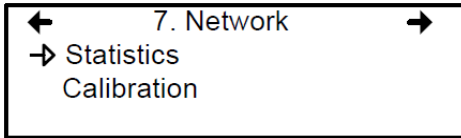

Selecting Statistics from the Network menu displays a screen containing the statistics for the selected device address.

	Statistics	001
Valid	16	100%
Errors	0	0%
Timeouts	0	0%

Term	Description
Valid	Indicates the number of valid responses for the last 16 requests
Errors	Indicates the number of errors in the response for the last 16 requests
Timeouts	Indicates the number of timeouts (no response) for the last 16 requests

Remote Calibration

The network menu also offers a Calibration option for use with devices that support network calibration.

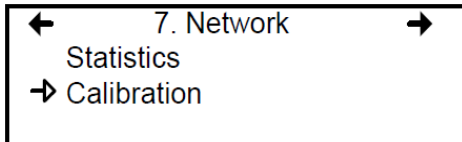

The Calibration screen contains four lines of information:

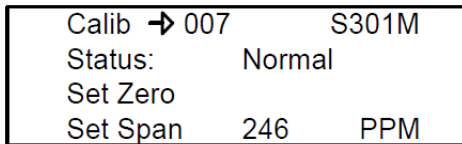

Term	Description
Line 1	Indicates the mode (Calib, meaning calibration), the (Modbus) address of the device to calibrate (001) and the type of device to calibrate (301D2)
Line 2	Indicates the status (Normal or In calib...) of the specified device
Line 3	Displays the function to perform (Set Zero)
Line 4	Displays the function to perform (Set Span) and the span gas concentration value (246 ppm)

1. On the first line, scroll to the device address and press Enter
2. Scroll through the devices to display the desired device* and press Enter to select.
3. The second line displays the device's status
4. Scroll to select the desired function, Set Zero to set the device's zero, and press Enter to select.
5. Upon pressing Set Zero, the controller requests confirmation.

Calib	007	S301M
Status:	Normal	
→ Set Zero		
Set Span	246	PPM

**The device must be configured in the 301C controller's database in order to be included in the device addresses displayed on screen.*

6. Press Enter to confirm or Esc to cancel. If confirmed, the controller calibrates the sensor's Zero. This takes only a few moments and the display returns to the default calibration screen.

Note: Never calibrate any unit's Zero with ambient air. Always use Nitrogen (N₂) at the calibration port to calibrate the Zero.

7. To calibrate the device, scroll to Set Span** and change the span gas calibration value using this procedure;

```
Calib 001 : 301D2
Status : Normal
Set Zero
Set Span → 2.60 ppm
```

- a. Using the right arrow, move the cursor to xxx PPM (span value field). Press Enter to select the field (it is editable when flashing).
- b. Use the up or down arrows to increase or decrease the value, press Enter to validate the new value.
- c. Move the cursor back to Set Span and press Enter to start the calibration.

```
Calib 001 : 301D2
Status : In calib...
Set Zero
→ Set Span 2.60 ppm
```

The device Span is being calibrated. The screen will display the device's status as "In calib..." until the calibration is complete.

***When selecting Set Span, make sure that the device has been supplied with the appropriate calibration gas before and during the calibration process.*

8. Tests Menu

The Tests menu allows a variety of tests to be performed on components and on the network communications. It also allows the system to be operated in four different modes which, in turn, provide different functionalities.

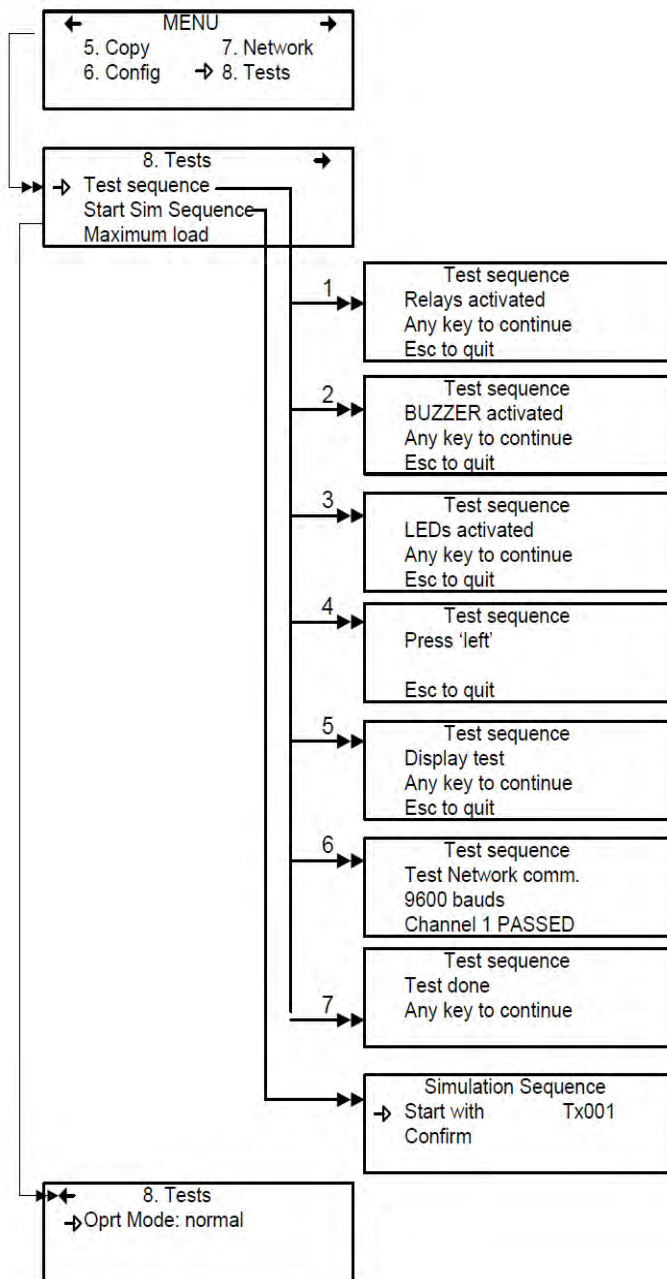

The Tests menu provides four main options, divided between two screens. Each of these options offers different capabilities. The first screen presents three options:

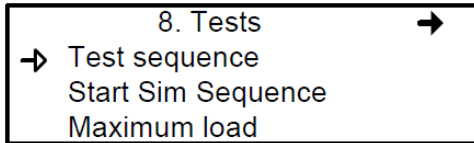

Option	Description
Test sequence	Enables each output to be activated and validates operation of each controller keypad buttons, display pixels, and various communication protocols.
Start Sim Sequence	This options starts or stops the Simulation mode, which allows a simulation of a gas concentration over an associated scale range on all transmitters. The simulated gas concentration values are local (on the controller) and do not affect logging functions. (Events will be activated for the simulation but detection devices are not affected.)
Maximum load	Activates all controller components

The second screen option is “Oprt Mode”, which offers three separate operation settings: Normal, Single Tx or Debug.

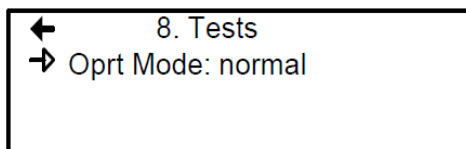

Setting	Description
Normal	Normal controller operation mode
Single Tx	Activates the polling mode on a single transmitter.
Debug	Activates the service mode to perform a calibration and to test Events without triggering actions.

Test Sequence

When test sequence is selected from the main Tests menu, the controller will display the Test sequence screen.

```
Test sequence
Relays activated
Any key to continue
Esc to quit
```

If Esc is pressed on the keypad, the main Tests menu screen will be displayed. However, to perform system tests, press any key to proceed to the first test screen.

```
Test sequence
BUZZER activated
Any key to continue
Esc to quit
```

This screen tests each component individually and will advance only to the next component when a key is pressed. This option will display 13 screens. Screens 1, 2, and 3 test Relays, BUZZER and LEDs.

The following six screens prompt the user to press the keypad buttons, in turn: left, right, up, down, Silence, Enter and Esc. The system will not advance until a key is pressed.

```
Test sequence
Press 'left'

Esc to quit
```

The system then moves to the Display test. When the blank screen is displayed, it is testing for display pixels. Press any key to proceed to the next step.

```
Test sequence
Display test
Any key to continue
Esc to quit
```

The final test that the system performs is a network communication test:

```
Test sequence
Test Network comm.
9600 bauds
Channel 1 PASSED
```

Once these tests have begun, do not interrupt or stop them.

When the system has completed the test, it displays the final Tests screen. Press any key to return to the main Tests menu.

```
Test sequence
Test done
Any key to continue
```

Normal Mode

This is the system's normal (default) operation mode. When the system is in normal mode, some values can be changed without interrupting services. When a value has been changed in any of the menu fields, the change will take effect upon returning to the main menu screen.

Single Tx Mode

This mode allows transmitters to be analyzed one at a time. The controller polls only the selected device, which subsequently has its information updated. This mode does not interfere with Event Evaluation functions.

Debug Mode

This mode allows complete system operation to be evaluated and tested without affecting operations (outside of debug mode). **Events are evaluated and displayed as necessary but no action is triggered.**

Simulation Mode

This mode deactivates network communication Information Updates. It can be combined with any of the three previous modes (example: using the Simulation mode when in Debug mode allows the user to test the entire system [groups, events, etc] without triggering any actions or using any additional material such as gases). It allows gas concentrations to be simulated over an associated scale for each transmitter, sequentially:

Alarm levels A, B and C are evaluated according to the simulated gas concentration and events are evaluated and actions are taken.

This type of alarm simulation at the controller does not work with certain transmitters with falling alarms. In these cases, an alarm can be simulated at the transmitter.

While in simulation mode, the controller is unaware of the device's actual network status. This mode can be stopped at any time in the Test menu (see Normal System Operation).

If one of these modes has been activated, the system will automatically return to Normal Mode after 12 hours of inactivity. (No changes will be lost.)

9. BACnet Menu

The BACnet menu on the following page offers several main menu screens to configure the BACNET IP connection, DHCP, server, time zone information and more. Communications parameter changes to the BACnet interface may not be implemented for up to 30 seconds after modification. These parameters include the device ID, the IP address, and the subnet mask.

BACnet/IP Module

(BIP option)

This section configures the optional BACnet interface (included with models with “BIP” in the part number).

The 301C BACnet/IP interface has been listed by BACnet Testing Labs as complying with the BACnet protocol version 7.



BACnet is a registered trademark of ASHRAE. ASHRAE does not endorse, approve or test products for compliance with ASHRAE standards. Compliance of listed products to the requirements of ASHRAE Standard 135 is the responsibility of BACnet International (BI). BTL is a registered trademark of BI.

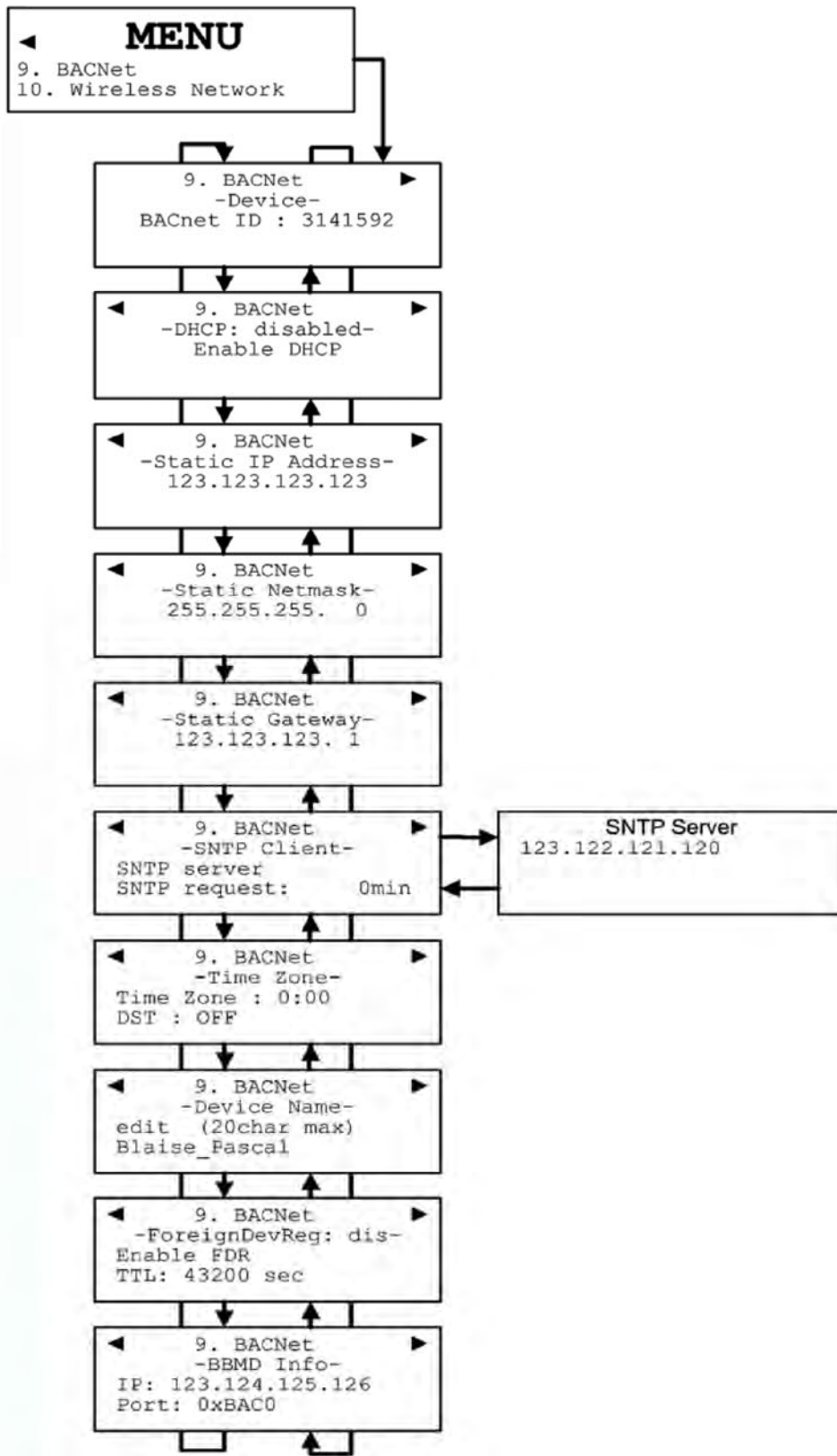

The first of these screens allows the identification and address to be configured:

```
9. BACNet      →
  -Device-
BACnet ID : 1
Static IP address
```

BACnet ID: (Building Automation and Control Networks) is the device ID number assigned to this particular controller on a network.

```
◀ 9. BACNet ▶
  -Static IP Address-
123.123.123.123
```

Static IP address: This is an address that is used when DHCP is disabled.

Changing BACNet values

- Use the keypad arrows to scroll down to select the desired line and press Enter to select it.
- Selecting BACnet ID activates the field. The ID value (0-4194303) can be increased or decreased using the up or down keypad arrows

If the Static IP address option is selected, the following screen appears. All controllers are shipped with a preset IP address as shown in the example below.

```
→ -IP address-
192.168. 1.254
  -Network mask-
255.255.255. 0
```

The next screen allows the device DHCP (Dynamic Host Configuration Protocol) to be enabled or disabled.

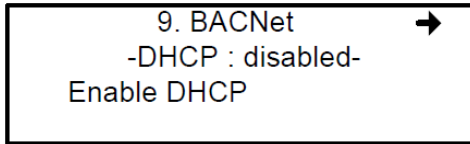

- Press Enter to change the field value.

The Device Name screen allows a specific name to be assigned to the BACNet device.

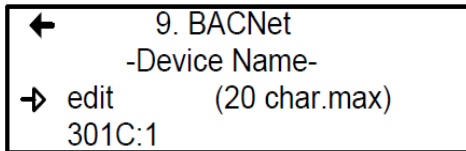

For more information on this subject, please consult the ASHRAE standard number 135-2001, Annex J, section J5.

The BACnet port number is fixed at hexadecimal 0xBAC0 or decimal 47808. It will not function with other port numbers.

The tables on pages 77-90 are also available on the Honeywell Analytics' Commercial Products CD that accompanied the 301C controller and from the Honeywell Analytics technical library

Device Object

Group	Property	Data Type	Required ¹	Storage Type ²	BACnet Writeable?	Value
Device	object_identifier	unsigned	R	N	N	Set from LUI
	object_type	enumerated	R	C	N	device (8)
	vendor_identifier	enumerated	R	C	N	Honeywell Inc. (17)
	apdu_timeout	unsigned	R	C	N	0
	application_software_version	character string	R	C	N	"1.1"
	firmware_revision	character string	R	C	N	"1.4.9"
	max_apdu_length_accepted	unsigned	R	C	N	1476
	model_name	character string	R	C	N	"301C-BIP"
	number_of_apdu_retries	unsigned	R	C	N	0
	object_name	character string	R	N	N	default "VA301C:1", settable from LUI.
	protocol_object_types_supported	bit string	R	C	N	device, analog_input, and binary_input. If configured, analog_value objects appear, but this is outside of BTL approval.
	protocol_services_supported	bit string	R	C	N	readProperty, readPropertyMultiple, writeProperty, who_Has, who_Is,
	protocol_version	unsigned	R	C	N	1
	segmentation_supported	enumerated	R	C	N	no_segmentation (3)
	system_status	enumerated	R	C	N	operational (0)
	vendor_name	character string	R	C	N	Honeywell
protocol_revision	unsigned	R	C	N	7	
database_revision	unsigned	R	C	N	increments as objects added.	
	Notes					
	1 --	'R' indicates that this property is required by ASHRAE Standard 135				
		'O' indicates that the property is optional in ASHRAE Standard 135				
	2 --	'C' indicates the property is hard-coded as a constant				
		'N' indicates the property is stored in non-volatile memory				
		'R' indicate the property is computed constantly and stored in RAM.				

Base Objects

Group	Property	Data Type	Required ¹	Storage Type ²	BACnet Writeable?	Value	
Binary Inputs	rel1 to rel4	object_identifier	R	C	N	46344 (or 0xB508) for Relay #1 up to 46347 (or 0xB50B) for Relay #4	
		object_type	enumerated	R	C	N	binary_input (3)
		event_state	enumerated	R	C	N	normal (0)
		object_name	character string	R	N	N	"device_object_name .relX", where device_object_name is programmed on the LUI and defaults to "VA301C:1" and X is relay number (1 to 4). Thus the default object_name for Relay #4 will be "VA301C:1.rel4"
		out_of_service	boolean	R	C	N	FALSE
		polarity	enumerated	R	C	N	always Normal (0)
		present_value	enumerated	R	R	N	True if and only if the relay is driven by an event. This bit is not inverted by "failsafe" (normally energized) mode.
		reliability	enumerated	O	C	N	no_fault_detected (0)
		status_flags					
		in_alarm	boolean	R	C	N	always "false" (0)
	fault	boolean	R	C	N	always "false" (0)	
	overridden	boolean	R	R	N	always "false" (0)	
	out_of_service	boolean	R	R	N	always "false" (0)	
	buzz	object_identifier		R	C	N	46360 (or 0xB518)
		object_type	enumerated	R	C	N	binary_input (3)
		event_state	enumerated	R	C	N	normal (0)
		object_name	character string	R	N	N	"device_object_name .buzz", where device_object_name is programmed on the LUI and defaults to "VA301C:1". Thus the default object_name will be "VA301C:1.buzz"
		out_of_service	boolean	R	C	N	FALSE
		polarity	enumerated	R	C	N	always Normal (0)
		present_value	enumerated	R	R	Y	True state of the buzzer.
reliability		enumerated	O	C	N	no_fault_detected (0)	
status_flags							
in_alarm		boolean	R	C	N	always "false" (0)	
fault	boolean	R	C	N	always "false" (0)		
overridden	boolean	R	C	N	always "false" (0)		
out_of_service	boolean	R	C	N	always "false" (0)		

IAQPoint2

Group	Property	Data Type	Required ¹	Storage Type ²	BACnet Writeable?	Value
Analog Inputs IAQPoint CO2	object_identifier		R	C	N	Modbus address * 256 + 1. For example an IAQPoint2 at Modbus address 005 will appear as 1281 or 0x0501.
	object_type	enumerated	R	C	N	analog_input (0)
	event_state	enumerated	R	R	N	if gas sensor fault Fault (1), else normal (0)
	object_name	character string	R	N	N	"IAQPoint CO2 AdXXX.CO2" where XXX is the Modbus address.
	out_of_service	boolean	R	R	N	FALSE
	present_value	real	R	R	N	Gas reading if CO2 fitted, 0 to 5000 if VOC fitted, 0 to 100
	reliability	enumerated	O	R	N	As appropriate reports no_fault_detected (0) or no_sensor (1) or unreliable other (7) Fault is detected within 60 seconds
	status_flags					
	in_alarm	boolean	R	R	N	if fault "true" (1) else "false" (0)
	fault	boolean	R	R	N	if fault "true" (1) else "false" (0)
	overridden	boolean	R	R	N	"false" (0)
	out_of_service	boolean	R	R	N	"false" (0)
	units	enumerated	R	N	N	if CO2 fitted, ppm (96) if VOC fitted, % (98)

continued...

IAQPoint2 continued

Group	Property	Data Type	Required ¹	Storage Type ²	BACnet Writeable?	Value
Analog Inputs IAQPoint ToC	object_identifier		R	C	N	Sensor number * 256 + 1. Sensor number for temperature is Modbus address + 1. For example an IAQPoint2 at Modbus address 005 will appear as 1537 or 0x0601.
	object_type	enumerated	R	C	N	analog_input (0)
	event_state	enumerated	R	R	N	if temp sensor fault, fault (1), else normal (0)
	object_name	character string	R	N	N	"IAQPoint ToC AdXXX.ToC" where XXX is the Modbus address plus one.
	out_of_service	boolean	R	R	N	FALSE
	present_value	real	R	R	N	Temperature reading in Celcius, regardless of IAQPoint2 configuration.
	reliability	enumerated	O	R	N	As appropriate reports no_fault_detected (0) or no_sensor (1) or unreliable other (7)
	status_flags					Fault is detected within 60 seconds
	in_alarm	boolean	R	R	N	if not purchased or faulty "true" (1) else "false" (0)
	fault	boolean	R	R	N	if not purchased or faulty "true" (1) else "false" (0)
	overridden	boolean	R	C	N	"false" (0)
	out_of_service	boolean	R	R	N	"false" (0)
	units	enumerated	R	N	N	Celcius (62)

continued...

IAQPoint2 continued

Group	Property	Data Type	Required ¹	Storage Type ²	BACnet Write able?	Value
Analog Inputs IAQPoint RH	object_identifier		R	C	N	Sensor number * 256 + 1. Sensor number for RH is Modbus address + 2. For example an IAQPoint2 at Modbus address 005 will appear as 1793 or 0x0701.
	object_type	enumerated	R	C	N	analog_input (0)
	event_state	enumerated	R	R	N	if temp sensor fault, fault (1), else normal (0)
	object_name	character string	R	N	N	"IAQPoint RH AdXXX.RH" where XXX is the Modbus address plus two.
	out_of_service	boolean	R	R	N	FALSE
	present_value	real	R	R	N	Relative Humidity in percent
	reliability	enumerated	O	R	N	As appropriate reports no_fault_detected (0) or no_sensor (1) or unreliable other (7) Fault is detected within 60 seconds
	status_flags					
	in_alarm	boolean	R	R	N	if not purchased or faulty "true" (1) else "false" (0)
	fault	boolean	R	R	N	if not purchased or faulty "true" (1) else "false" (0)
	overridden	boolean	R	C	N	"false" (0)
	out_of_service	boolean	R	R	N	"false" (0)
units	enumerated	R	N	N	percent_relative_humidity (29)	

E³Point

Group	Property	Data Type	Required ¹	Storage Type ²	BACnet Writeable?	Value
analog_input gas	object_identifier		R	C	N	Modbus address * 256 + 1. For example an E3Point at Modbus address 009 will appear as 2305 or 0x0901.
	object_type	enumerated	R	C	N	analog_input (0)
	event_state	enumerated	R	R	N	if gas sensor fault Fault (1), if alarm offnormal (2) else normal (0)
	object_name	character string	R	N	N	"E3POINT GGGG AdXXX.GGGG" where GGGG is the gas name and XXX is the Modbus address. Values for gas name include "CO" and "COMB".
	out_of_service	boolean	R	R	N	FALSE
	present_value	real	R	R	N	Gas reading
	reliability	enumerated	O	R	N	As appropriate reports no_fault_detected (0) or unreliable other (7) Fault is detected within 60 seconds
	status_flags					
	in_alarm	boolean	R	R	N	if alarm or fault "true" (1) else "false" (0)
	fault	boolean	R	R	N	if fault "true" (1) else "false" (0)
	overridden	boolean	R	R	N	"false" (0)
	out_of_service	boolean	R	R	N	"false" (0)
	units	enumerated	R	N	N	ppm (96) or % (98)

continued...

E³Point continued

Group	Property	Data Type	Required ¹	Storage Type ²	BACnet Writeable?	Value	
Binary Inputs	rel1 (really buzzer)	object_identifier	R	C	N	Modbus address * 256 + 8. For example an E3Point at Modbus address 009 will appear as 2312 or 0x0908.	
		object_type	enumerated	R	C	N	binary_input (3)
		event_state	enumerated	R	C	N	normal (0)
		object_name	character string	R	N	N	"E3POINT GGGG AdXXX.rel1" where GGGG is the gas name and XXX is the Modbus address. Values for gas name include "CO" and "COMB".
		out_of_service	boolean	R	C	N	FALSE
		polarity	enumerated	R	C	N	always Normal (0)
		present_value	enumerated	R	R	Y	True if and only if the buzzer is driven by an event.
		reliability	enumerated	O	C	N	no_fault_detected (0)
		status_flags					
		in_alarm	boolean	R	C	N	always "false" (0)
	fault	boolean	R	C	N	always "false" (0)	
	overridden	boolean	R	R	N	always "false" (0)	
	out_of_service	boolean	R	R	N	always "false" (0)	
	rel2 (physical relay)	object_identifier		R	C	N	Modbus address * 256 + 9. For example an E3Point at Modbus address 009 will appear as 2313 or 0x0909.
		object_type	enumerated	R	C	N	binary_input (3)
		event_state	enumerated	R	C	N	normal (0)
		object_name	character string	R	N	N	"E3POINT GGGG AdXXX.rel2" where GGGG is the gas name and XXX is the Modbus address. Values for gas name include "CO" and "COMB".
		out_of_service	boolean	R	C	N	FALSE
		polarity	enumerated	R	C	N	always Normal (0)
		present_value	enumerated	R	R	Y	True if and only if the relay is driven by an event. This bit is not inverted by "failsafe" (normally energized) mode.
reliability		enumerated	O	C	N	no_fault_detected (0)	
status_flags							
in_alarm		boolean	R	C	N	always "false" (0)	
fault	boolean	R	C	N	always "false" (0)		
overridden	boolean	R	C	N	always "false" (0)		
out_of_service	boolean	R	C	N	always "false" (0)		

XNX and XCD

Group	Property	Data Type	Required ¹	Storage Type ²	BACnet Writeable?	Value
analog_input gas	object_identifier		R	C	N	Modbus address * 256 + 1. For example an XNX at Modbus address 010 will appear as 2561 or 0x0A01.
	object_type	enumerated	R	C	N	analog_input (0)
	event_state	enumerated	R	R	N	if gas sensor fault Fault (1), if alarm offnormal (2) else normal (0)
	object_name	character string	R	N	N	"SSS GGGG AdAAA.GGGGG" where SSS is the sensor type, GGGG is the gas name and AAA is the Modbus address. Gas names are truncated to 4 and 5 characters. Values for sensor type are "XNX" or "XCD" For example, an XNX at address 10 with a Methane sensor will populate this object name with "XNX Meth Ad010.Metha"
	out_of_service	boolean	R	R	N	FALSE
	present_value	real	R	R	N	Gas reading
	reliability	enumerated	O	R	N	As appropriate reports no_fault_detected (0) or no_sensor (7) Fault is detected within 60 seconds
	status_flags					
	in_alarm	boolean	R	R	N	if fault or alarm "true" (1) else "false" (0)
	fault	boolean	R	R	N	if fault "true" (1) else "false" (0)
	overridden	boolean	R	R	N	"false" (0)
	out_of_service	boolean	R	R	N	"false" (0)
	units	enumerated	R	N	N	96 (ppm) or 98 (percent) or 95 (no_units)

Objects for 301EM

Group	Property	Data Type	Required ¹	Storage Type ²	BACnet Writeable?	Value
analog_input Gas (One instance per sensor on the 301EM.)	object_identifier		R	C	N	TxNumber * 256 + 1. The TxNumber is the Modbus address plus the sensor number in the 301EM. For example, sensor 2 on a 301EM at Modbus address 030 will appear as 7937 or 0x1F01.
	object_type	enumerated	R	C	N	analog_input (0)
	event_state	enumerated	R	R	N	not meaningful
	object_name	character string	R	N	N	"VA301EM GGGG AdXXX.GGGG" where GGGG is the gas name and XXX is the Modbus address. Values for gas name include "R11" and "NH3".
	out_of_service	boolean	R	R	N	FALSE
	present_value	real	R	R	N	Gas reading
	reliability	enumerated	O	R	N	As appropriate reports no_fault_detected (0), no_sensor (1), or unreliable other (7) Fault is detected within 60 seconds
	status_flags					
	in_alarm	boolean	R	R	N	not meaningful
	fault	boolean	R	R	N	if fault "true" (1) else "false" (0)
	overridden	boolean	R	R	N	"false" (0)
	out_of_service	boolean	R	R	N	"false" (0)
	units	enumerated	R	N	N	From 301EM, usually ppm (96)

continued...

Objects for 301EM continued

Group	Property	Data Type	Required ¹	Storage Type ²	BACnet Writeable?	Value
Binary inputs (Seven instances per 301EM, regardless of sensors set.) rel1 to rel4, buzzer, out1 to out3	object_identifier		R	C	N	For rel1, Modbus address * 256 + 8, For rel2, Modbus address * 256 + 9, For rel3, Modbus address * 256 + 10, For rel4, Modbus address * 256 + 11 For Buzzer, Modbus address * 256 + 24, For Out1, Modbus address * 256 + 25, For Out2, Modbus address * 256 + 26, For Out3, Modbus address * 256 + 27
	object_type	enumerated	R	C	N	binary_input (3)
	event_state	enumerated	R	C	N	normal (0)
	object_name	character string	R	N	N	"VA301EM GGGG AdXXX.DDDD" where GGGG is the gas name and XXX is the Modbus address. DDDD can have the values "Rel1" ... "Rel3", "out1"... "out3" or "buzz".
	out_of_service	boolean	R	C	N	FALSE
	present_value	enumerated	R	R	N	True if the output is active.
	reliability	enumerated	0	C	N	not meaningful.
	status_flags					
	in_alarm	boolean	R	C	N	not meaningful.
	fault	boolean	R	C	N	not meaningful.
	overridden	boolean	R	R	N	always "false" (0)
	out_of_service	boolean	R	R	N	always "false" (0)

EC-FX

Group	Property	Data Type	Required ¹	Storage Type ²	BACnet Write able?	Value
analog_input gas	object_identifier		R	C	N	Modbus address * 256 + 1. For example an EC-F9 at Modbus address 003 will appear as 769 or 0x0301.
	object_type	enumerated	R	C	N	analog_input (0)
	event_state	enumerated	R	R	N	if gas sensor fault Fault (1), if alarm offnormal (2) else normal (0)
	object_name	character string	R	N	N	"EC-F9 GGGG AdXXX.GGGG" where GGGG is the gas name and XXX is the Modbus address. The gas name is often "NH3".
	out_of_service	boolean	R	R	N	FALSE
	present_value	real	R	R	N	Gas reading
	reliability	enumerated	O	R	N	As appropriate reports no_fault_detected (0) or unreliable other (7) Fault is detected within 60 seconds
	status_flags					
	in_alarm	boolean	R	R	N	if alarm or fault "true" (1) else "false" (0)
	fault	boolean	R	R	N	if faulty "true" (1) else "false" (0)
	overridden	boolean	R	R	N	"false" (0)
	out_of_service	boolean	R	R	N	"false" (0)
	units	enumerated	R	N	N	Usually ppm (96)

420MDBS_IR-F9

Group	Property	Data Type	Required ¹	Storage Type ²	BACnet Writeable?	Value
analog_in gas	object_identifier		R	C	N	Modbus address * 256 + 1. For example an 420MDBS at Modbus address 002 will appear as 513 or 0x0201.
	object_type	enumerated	R	C	N	analog_input (0)
	event_state	enumerated	R	R	N	if gas sensor fault Fault (1), if alarm offnormal (2) else normal (0)
	object_name	character string	R	N	N	"420MDBS GGGG AdXXX.GGGG" where GGGG is the gas name and XXX is the Modbus address. Values for gas name include "NH3".
	out_of_service	boolean	R	R	N	FALSE
	present_value	real	R	R	N	Gas reading
	reliability	enumerated	O	R	N	As appropriate reports no_fault_detected (0) or unreliable other (7)
	status_flags					
	in_alarm	boolean	R	R	N	if alarm or fault "true" (1) else "false" (0)
	fault	boolean	R	R	N	if faulty "true" (1) else "false" (0)
	overridden	boolean	R	R	N	"false" (0)
	out_of_service	boolean	R	R	N	"false" (0)
	units	enumerated	R	N	N	Depends on configuration of 420MDBS factory configuration or 301C configuration, usually ppm (96)

301ADI

Group	Property	Data Type	Required ¹	Storage Type ²	BACnet Write able?	Value
analog_inputs (Up to 16 if configured enabled on the 301ADI user interface.)	object_identifier		R	C	N	(Modbus address+channel number) * 256 - 255, where channel number is 1 to 16. For example analog input 7 from a 301ADI at address 097 will appear as 26369 or 0x6107.
	object_type	enumerated	R	C	N	analog_input (0)
	event_state	enumerated	R	R	N	not meaningful.
	object_name	character string	R	N	N	"AdXXX.AI.CC" where CC is the channel number from 1 to 16 and XXX is the Modbus address.
	out_of_service	boolean	R	R	N	FALSE
	present_value	real	R	R	N	Reading from 301C, mA by default. Scaling in the 301C is supported.
	reliability	enumerated	O	R	N	not meaningful.
	status_flags					
	in_alarm	boolean	R	R	N	not meaningful.
	fault	boolean	R	R	N	"false" (0)
	overridden	boolean	R	R	N	"false" (0)
	out_of_service	boolean	R	R	N	"false" (0)
	units	enumerated	R	N	N	mA (02) by default. Reconfiguration in the 301C is possible. New units may not propagate until a power cycle.

301R

Group	Property	Data Type	Required ¹	Storage Type ²	BACnet Write able?	Value
Binary Inputs rel1 to rel8	object_identifier		R	C	N	RelayNumber + Modbus address * 256 + 7. For example Relay 4 in a 301R at Modbus address 095 will appear as 24331 or 0x5F0B.
	object_type	enumerated	R	C	N	binary_input (3)
	event_state	enumerated	R	C	N	normal (0)
	object_name	character string	R	N	N	"VA301R AdXXX.relR" where XXX is the Modbus address and R is the relay number.
	out_of_service	boolean	R	C	N	FALSE
	polarity	enumerated	R	C	N	always Normal (0)
	present_value	enumerated	R	R	N	True if and only if the relay is driven by an event.
	reliability	enumerated	0	C	N	no_fault_detected (0)
	status_flags					
	in_alarm	boolean	R	C	N	always "false" (0)
	fault	boolean	R	C	N	always "false" (0)
	overridden	boolean	R	R	N	always "false" (0)
	out_of_service	boolean	R	R	N	always "false" (0)

ANNEX A - PROTOCOL IMPLEMENTATION CONFORMANCE STATEMENT (NORMATIVE)

(This annex is part of this Standard and is required for its use.)

BACnet Protocol Implementation Conformance Statement

Date:

_____2015May07_____

Vendor Name: _____Honeywell International_____

Product Name: _____301C Controller_____

Product Model Number: _____301C-DLC-BIP, AA96D-DLC-BIP_____

Application Software Version: 1.1 Firmware Revision:

1.4.9 BACnet Protocol Revision: 7

Product Description:

Gas Detection controller offering unique zoning capabilities which permit the averaging and comparison of multiple sensor readings. Up to 96 sensors including the E3Point and the Senspoint XCD may be connected. Includes 4 relays. Available in a heavy duty industrial housing and with a datalogging option.

BACnet Standardized Device Profile (Annex L):

- BACnet Operator Workstation (B-OWS)
- BACnet Advanced Operator Workstation (B-AWS)
- BACnet Operator Display (B-OD)
- BACnet Building Controller (B-BC)
- BACnet Advanced Application Controller (B-AAC)
- BACnet Application Specific Controller (B-ASC)
- BACnet Smart Sensor (B-SS)
- BACnet Smart Actuator (B-SA)

List all BACnet Interoperability Building Blocks Supported (Annex K):

- Data Sharing-ReadProperty-B (DS-RP-B)

- **Data Sharing-ReadPropertyMultiple-B (DS-RPM-B)**
- **Data Sharing-WriteProperty-B (DS-WP-B)**
- **Device Management-Dynamic Object Binding-B (DM-DOB-B)**
- **Device Management-Dynamic Device Binding-B (DM-DDB-B)**
- **Device Management-TimeSynchronization-B (DM-TS-B)**

Segmentation Capability:

Able to transmit segmented messages Window Size ____

Able to receive segmented messages Window Size ____

Standard Object Types Supported:

Object	Dynamically Creatable?	Dynamically Deletable?	Optional Properties Supported	Writable Beyond Standard	Range Restrictions
device	N	N	local_date local_time UTC_offset Day-light_Savings_Stat atus	N	none
analog_input	N	N	reliability	N	none
binary_input	N	N	reliability	N	none

Data Link Layer Options:

- BACnet IP, (Annex J)
- BACnet IP, (Annex J), Foreign Device

Device Address Binding:

Is static device binding supported? (This is currently necessary for two-way communication with MS/TP slaves and certain other devices.) Yes No

Networking Options:

- Router, Clause 6 - List all routing configurations, e.g., ARCNET-Ethernet, Ethernet-MS/TP, etc.
- Annex H, BACnet Tunneling Router over IP

- BACnet/IP Broadcast Management Device (BBMD)
 - Does the BBMD support registrations by Foreign Devices?
 - Yes No
 - Does the BBMD support network address translation?
 - Yes No

Network Security Options:

- Non-secure Device - is capable of operating without BACnet Network Security

Character Sets Supported:

- ISO 10646 (UTF-8) IBM™/Microsoft™ DBCS
- ISO 8859-1
- ISO 10646 (UCS-2) ISO 10646 (UCS-4) JIS
- X 0208

If this product is a communication gateway, describe the types of non-BACnet equipment/networks(s) that the gateway supports:

This supports translating data from Honeywell Analytics proprietary Modbus-RTU gas detectors to BACnet/IP. Supported detectors include the E3Point and the SensePoint XCD.



10. Wireless network

Not supported.

How to Build a Title 24 Compliant System

California Title 24 Part 6 specifies mandatory requirements for enclosed parking garages. A compliant gas detection system can be constructed from the Honeywell Analytics 301C24 and E³Point Network gas sensor. This section describes how to configure the 301C controller to accomplish this.

Glossary

The terminology for a couple of technical concepts differs between Honeywell and California.

California's Term	Honeywell's Term	Description
proximity zone	group	A region of a garage containing several sensors. Gas readings in the region are presumed to be similar because of free air circulation.
alarm	fault	A notification from the gas detection system that the system is not working correctly.

Requirement: Section 120.6(c)4 "CO concentration at all sensors is maintained at 25 ppm or less at all times."

Solution: Create an event for each group such that if one or more sensors report a concentration greater than 25 ppm the event is activated.



Requirement: Section 120.6(c)7 A-D “CO sensor shall be:

- A. Certified by the manufacturer to be accurate within plus or minus 5 percent of measurement.
- B. Factory calibrated.
- C. Certified by the manufacturer to drift no more than 5 percent per year.
- D. Certified by the manufacturer to require calibration no more frequently than once a year.

Solution: Use Honeywell Analytics E3Point Network Gas Monitor with carbon monoxide cartridges.

Requirement: Section 120.6(c)7Ei “The CO sensor shall be monitored by a control system. If any sensor has not been calibrated according to the manufacturer’s recommendations within the specified calibration period, the sensor has failed.”

Solution: Use E3Point carbon monoxide sensors, which require calibration every 12 months. Create a event to activate if time since calibration (TSC) is 12 months. Configure this event to activate fans and the alarm device.

```
← 3.   EVENT   001 →  
( 1or+ Gr001  Ⓚ ) ---  
  TSC →12 mon )
```

Requirement: Section 120.6(c)7Eiii “The CO sensor shall be monitored by a control system. During occupied periods the system compares the readings of sensors in the same proximity zone, e.g. if the 30 minute rolling average for any sensor in a proximity zone is more than 15 ppm above or below the 30 minute rolling average for other sensor(s) in that proximity zone, the sensor has failed.”

Solution: Create an event to activate if the concentration reading of any sensor in a group is an outlier deviating by 15 ppm for longer than 30 minutes.

```
← 3.  EVENT  002  →
(  Outl  Gr001  Ⓞ  )  ---
  dev   15ppm
  dur   →30 min
```

Requirement: Section 120.6(c)7Eii “The CO sensor shall be monitored by a control system. During unoccupied periods the system compares the readings of all sensors, e.g. if any sensor is more than 15 ppm above or below the average of all sensors for longer than 4 hours, the sensor has failed.”

Solution: Configure an event to activate if the concentration reading of any sensor in a group is an outlier deviating by 15 ppm for longer than 4 hours.

```
← 3.  EVENT  002  →
(  Outl  Gr001  Ⓞ  )  ---
  dev   15ppm
  dur   →04 hr
```

Note that this requirement is less strict than Section 120.6(c)7Eiii above because the aberrant reading is allowed to persist longer. Thus this requirement is only meaningful for garages that are rarely occu-

ped. And the only rationale for implementing this looser requirement would be to avoid superfluous faults.

The 301C controller can discriminate between occupied and unoccupied duration limits this by making two outlier events (for 30 minutes and 4 hours) and making the 30 minute event coverage period only “Daytime”. The hours of “Daytime” can be set under menu function 6. If occupancy is based on some other criterion than the time of day, this binary condition can be accepted into the 301C controller system by a digital input channel of a 301ADI. The event can be made conditional on the outlier and the digital input.

Note: The following requirements are from the The 2013 Nonresidential Compliance Manual Appendix A form NRCA-PRC-03-F “Enclosed Parking Garage Exhaust System Acceptance”

Requirement: Step A 3 instructs “Temporarily override the programmed sensor calibration/ replacement period to 5 minutes.”

Solution: Reconfigure the time since calibration (TSC) event time limit to 0 minutes. Alternatively, a stale cartridge can be temporarily plugged into the E³Point.



Note that the 301C controller/E³Point system reports time since calibration in days. Therefore, setting the time limit to 5 minutes would cause an event to activate 1140 minutes (1 day) after calibration.

Requirement: Form NRCA-PRC-03-F step A 4 instructs “Temporarily place the system in unoccupied mode and override the programmed unoccupied sensor alarm differential from 30% for 4 hours to 1% for 5 minutes.”

Solution: Note that the 301C controller measures deviation in ppm, not percent. Change the event screen to outlier deviation 0 ppm duration 5 minutes.



Note that Honeywell Analytics E3Point CO sensors have a resolution of 1 ppm.

Requirement: Form NRCA-PRC-03-F step A 5 instructs “Temporarily override the programmed occupied sensor proximity zone alarm differential from 30% for 4 hours to 1% for 5 minutes.”

Solution: Like step A 4, Set the event screen to deviation 0 ppm and duration 5 minutes.



Specifications

Topic	Description
Power requirements	17-27 Vac, 50/60 Hz, 8.64 VA
	18-36 Vdc, 350mA @ 24 Vdc (8.4 VA)
Operating temperature range	-20°C to 50°C (-4°F to 122°F)
Operating humidity range	0 to 95% RH (non-condensing)
Operating altitude	Up to 3000 m (9843 ft)
Network capacity	Up to 96 transmitters, 32 per channel
	Channels 1, 2 = Modbus and Vulbus
	Channel 3 = Modbus only
Communication	Up to 609m (2,000 ft) per channel
User interface	Graphic 122 x 32 dot matrix backlit display
	User friendly keypad
Visual indicators	Power (green LED)
	Alarm A, B, C (red LED)
	Fault (yellow LED)
	Tx (yellow LED)
	Rx (green LED)
Outputs	4 DPDT relays
Output rating	5A, 30Vdc or 250 Vac (resistive load)
Audible alarm	65dBA at 1 m (3 ft)
Time delays	Programmable Before and After delays
Battery	3 volt lithium battery
Enclosure	ABS-polycarbonate - indoor use
Dimensions (HxWxD)	28 x 20.3 x 7cm (7.99" x 11.02" x 2.76")
Certifications	ANSI/UL 61010-1
	CAN/CSA C22.2 No. 61010-1
	ETL 116662

Limited Warranty

Limited Warranty

Honeywell Analytics, Inc. warrants to the original purchaser and/or ultimate customer ("Purchaser") of Vulcain products ("Product") that if any part thereof proves to be defective in material or workmanship within twelve (12) months, such defective part will be repaired or replaced, free of charge, at Honeywell Analytics' discretion if shipped prepaid to Honeywell Analytics in a package equal to or in the original container. The Product will be returned freight prepaid and repaired or replaced if it is de-termined by Honeywell Analytics that the part failed due to defective materials or workmanship. The repair or replacement of any such de-fective part shall be Honeywell Analytics' sole and exclusive responsi-bility and liability under this limited warranty.

Re-Stocking Policy

The following restocking fees will apply when customers return products for credit:

- 15% restocking fee will be applied if the product is returned within **1 month** following the shipping date
- 30% restocking fee will be applied if the product is returned within **3 months** following the shipping date

A full credit (less restocking fee) will only be issued if the product is in perfect working condition. If repairs are required on the returned product, the cost of these repairs will be deducted from the credit to be issued.

No credits will be issued beyond the three month period.

Exclusions

A. If Gas sensors are part of the Product, the gas sensor is covered by a twelve (12) month limited warranty of the manufacturer.

B. If gas sensors are covered by this limited warranty, the gas sensor is subject to inspection by Honeywell Analytics for extended exposure to excessive gas concentrations if a claim by the Purchaser is made under this limited warranty. Should such inspection indicate that the gas sensor has been expended rather than failed prematurely, this limited warranty shall not apply to the Product.

C. This limited warranty does not cover consumable items, such as batteries, or items subject to wear or periodic replacement, including lamps, fuses, valves, vanes, sensor elements, cartridges, or filter elements.

Warranty Limitation and Exclusion

Honeywell Analytics will have no further obligation under this limited warranty. All warranty obligations of Honeywell Analytics are extinguishable if the Product has been subject to abuse, misuse, negligence, or accident or if the Purchaser fails to perform any of the duties set forth in this limited warranty or if the Product has not been operated in accordance with instructions, or if the Product serial number has been removed or altered.

Disclaimer of Unstated Warranties

The warranty printed above is the only warranty applicable to this purchase. All other warranties, express or implied, including, but not limited to, the implied warranties of merchantability or fitness for a particular purpose are hereby disclaimed.

Limitation of Liability

It is understood and agreed that Honeywell Analytics' liability, whether in contract, in tort, under any warranty, in negligence or otherwise shall not exceed the amount of the purchase price paid by the purchaser for the product and under no circumstances shall Honeywell Analytics be liable for special, indirect, or consequential damages. The price stated for the product is a consideration limiting Honeywell Analytics' liability. No action, regardless of form, arising out of the transactions under this warranty may be brought by the purchaser more than one year after the cause of actions has occurred.