

VerifEye® Series 2500 Meter

Cat. No. 25B01
User Guide



TABLE OF CONTENTS

1	Warnings and Cautions	1
2	Tools Needed	2
3	Introduction	3
4	Installation	4
5	Configuring the Meter	9
6	Confirming the Installation and Configuration	15
7	Technical Specifications	18
8	Addendum	19
9	Standard Statements and Warranty	22



1 WARNINGS AND CAUTIONS

WARNINGS:

- **HAZARD OF ELECTROCUTION, SHOCK, EXPLOSION, OR ARC FLASH. CAREFULLY READ AND FOLLOW INSTRUCTIONS.**
- **TO AVOID FIRE, SHOCK OR DEATH**, turn OFF all power supplying equipment before working on or inside the equipment. Use a properly rated voltage sensing device to confirm power is OFF.
- Follow safe electrical work practices. See NFPA 70E in the USA, or applicable local codes.
- This equipment **MUST** be installed and serviced by an electrician or other qualified personnel with the requisite knowledge, training, and experience related to the installation and operation of this equipment.
- Product may use multiple voltage/power sources. Be sure all sources of power have been disconnected before servicing.
- Do not depend on this product for voltage indication.
- Only install this product on insulated conductors.
- If the meter appears damaged or defective, first disconnect all power to the meter. Then call or e-mail technical support for assistance.

This meter is designed to support the following electrical service types:

- 120/208VAC and 277/480VAC, 3-Phase/4 Wire Wye
- 240VAC, Split-Phase 3 wire

This meter DOES NOT support Delta service.

DO NOT EXCEED 304V Line to Neutral (L-N). Exceeding this voltage will cause damage to the meter and danger to the user. Always use a Potential Transformer (PT) for voltages in excess of 277V L-N.

VerifEye® Series 2500 meters are rated as 480 Volt (4-Wire) Over Voltage Category III devices.

For use in a Pollution Degree 2 or better environment only. A Pollution Degree 2 environment must control conductive pollution and the possibility of condensation or high-humidity. Consider the enclosure, the correct use of ventilation, thermal properties of the equipment, and the relationship with the environment.

Installation overvoltage category: CAT III.

Provide a disconnect device to disconnect the meter from the supply source. This disconnect should be clearly labeled as the disconnect for the Series 2500 meter. Place this device in close proximity to the equipment, within easy reach of the operator, and mark it as the disconnecting device. The disconnecting device must meet the requirements of the relevant safety standards, and be suitable for the application. In the US and Canada, disconnecting fuse holders can be used. Provide over-current protection and disconnecting device for supply conductors with approved current-limiting devices suitable for protecting the wiring. If the equipment is used in a manner not specified by the manufacturer, the protection provided by the device may be impaired.

CAUTIONS:

- Disconnect power from the meter before installing the current sensors.
- This product is not intended for life or safety applications.
- Do not install this product in hazardous or classified locations.
- The installer is responsible for compliance with all applicable codes.
- Mount this product inside a suitable fire and electrical enclosure.
- If the collector is connected directly to a source of voltage, the pulse isolator burns out immediately and becomes non-responsive.
- Do not use any cleaning agents, including water, on the device.
- No accessories are approved for use with the meter other than those specified in the Leviton Manufacturing product literature and price sheets.
- Current transformers may not be installed in equipment exceeding 75 percent of the wiring space of any cross-sectional area within the equipment.
- Current transformers (CTs) may not be installed in an area where they block ventilation openings.
- Current transformers (CTs) may not be installed in an area of breaker arc venting.
- Not suitable for Class 2 wiring method nor intended for connection to Class 2 equipment.
- Secure current transformers and route conductors so that they do not directly contact live terminals or buss.
- External secondary inputs and outputs should be connected to devices meeting the requirements of IEC 60950.
- For use only with listed energy-monitoring current transformers.
- Use this device with **copper or copper-clad wire only**.

2 TOOLS NEEDED

#	Product Name	Quantity
1	VerifEye® Series 2500 meter	1
2	Quick Start Guide	1
3	Mounting Tabs	4
4	Mounting Tab Screws (3/8")	4
5	Flush Mount Kit Toggle Anchors (Optional, sold separately)	4
6	Paintable Flush Mount Cover (Optional, sold separately)	1

Tools required before installing the meter:

- Wire stripper
- Phillips screwdriver
- Voltmeter or digital multimeter (for measuring AC voltage at the installation site)
- Level
- Pencil or marker
- Drill
- Hand saw

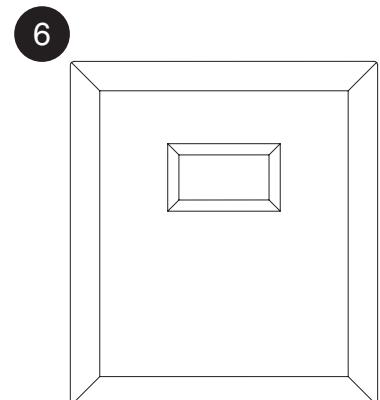
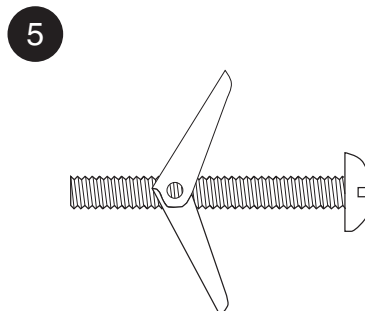
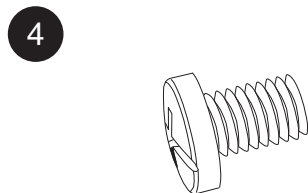
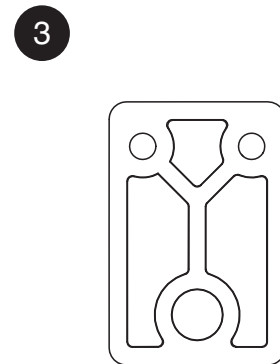
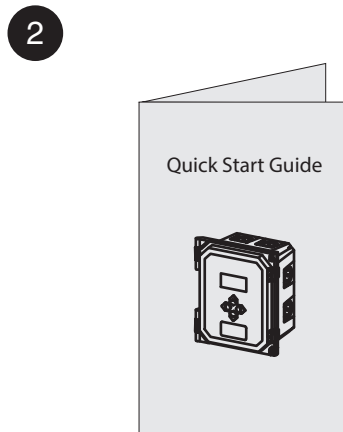
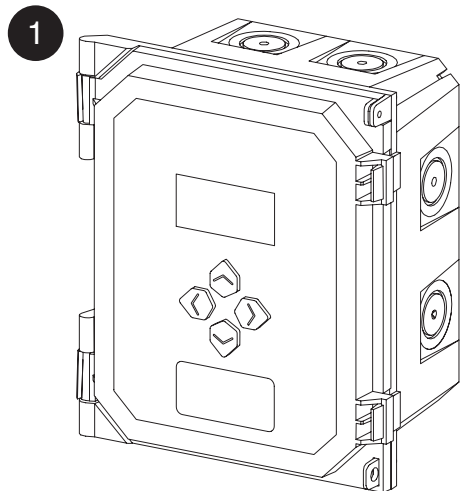

3 INTRODUCTION

The VerifEye® Series 2500 meters monitor the voltage, current, power, and energy parameters on single and three-phase electrical systems. A VerifEye® meter uses direct connections to each phase of the voltage and current transformers to monitor each phase of the current. Information on energy use, demand, power factor, line frequency, and more are derived from these voltage and current inputs.

These meters are not intended to be standalone energy recorders; rather they are connected as client devices to an Energy Monitoring Hub, or Building Management host network. The VerifEye® meter communication interfaces include pulse outputs and RS485 serial. Modbus RTU is the one of the most widely used communication protocols, operating over an RS485 serial network.

3.1 Unpacking the Unit

VerifEye® meters product features are identifiable by the part numbering scheme:

VerifEye® Part Numbering Scheme

- 25B01-000 3-Phase meter – 3 CT inputs, Modbus and pulse outputs
- 25B01-FMK Flush Mount Kit – faceplate & mounting hardware

Each VerifEye® Series 2500 meter includes the items below:

- Meter – Serial Number and FCC ID indicated on side label.
- Quick install guide (QR code with links to complete user documentation)
- Quick connect terminals for voltage input wiring
- Mounting feet for wall mounting

3.2 Meter Anatomy

All user connections are made on the circuit board, which is attached to the door. Connectors on the back of the board, are identified by function and include polarity markers.

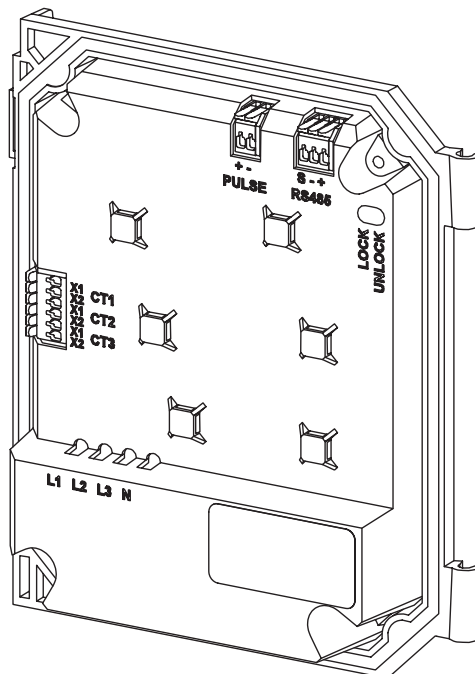

4 INSTALLATION

4.1 Planning for Installation

Things to consider:

- Modbus addresses – Because every Modbus device must have a unique address, preparing a list of devices and pre-assigning Modbus addresses will help to avoid duplications, which prevent devices from being recognized on the network.
- Panel schedules and naming conventions – It will be very helpful to prepare a list of circuit names and which breakers they are associated with in the panel, so naming these inputs in the meter and Energy Monitoring Hub are aligned.
- On this same panel schedule, include which CTs are installed on each circuit. This will be required for meter configuration.

Disclaimer:

- The device must be installed following the guidelines set forth in this document, or the inherent protection provided by the device may be compromised.
- This device is suitable for indoor or outdoor use. When used outdoors or in harsh environments, appropriate sealed fittings must be used, and the NEMA 3R rating must be maintained.
- Leviton products are not intended for use in critical applications such as nuclear facilities, or life support. Leviton is not liable in whole or in part, for any claims or damages arising from such uses.

4.2 Meter Installation

Meter Mounting Configurations:

VerifEye® Series 2500 meters are designed to be wall mounted and connected to electrical conduit. This enclosure may also be flush mounted into a wall using the optional flush mount kit, which includes a faceplate to cover the face of the meter, leaving only the LCD visible. The flush mount kit is sold separately.

CAUTION: Be careful not to flex the circuit board during installation

Mounting the Meter:

Conduit Entry Points:

The enclosure is pre-marked with knockout features all around the housing for locating the conduit fittings. The entry locations are designed for ½ inch conduit and fittings. Pre-drill in the marked locations where the wiring will enter the enclosure. Best practice is to use separate entries for low voltage and line voltage wiring. Reference voltage wiring is on the bottom of the meter, with the Modbus, pulse wiring on the top. CT wiring may be run in the same conduit with the reference voltage, or in a separate entry.

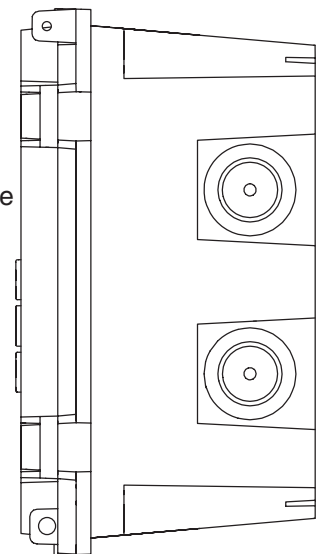

4 INSTALLATION

Wall Mounting:

1. Attach the mounting tabs to the back of the enclosure using the screws provided.

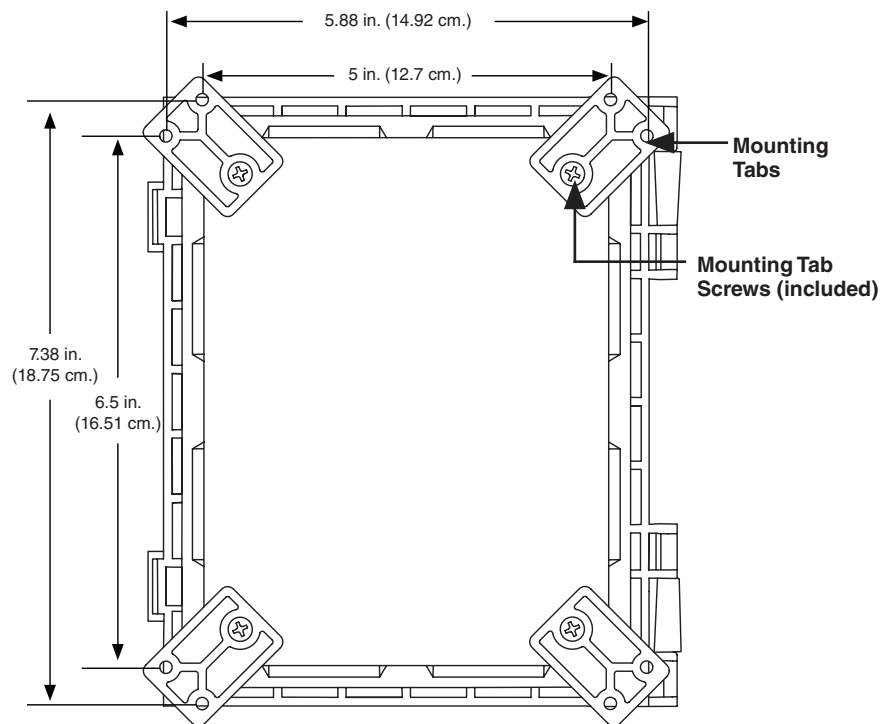

2. Mount the meter to the wall using these mounting tabs (mounting screws not provided).

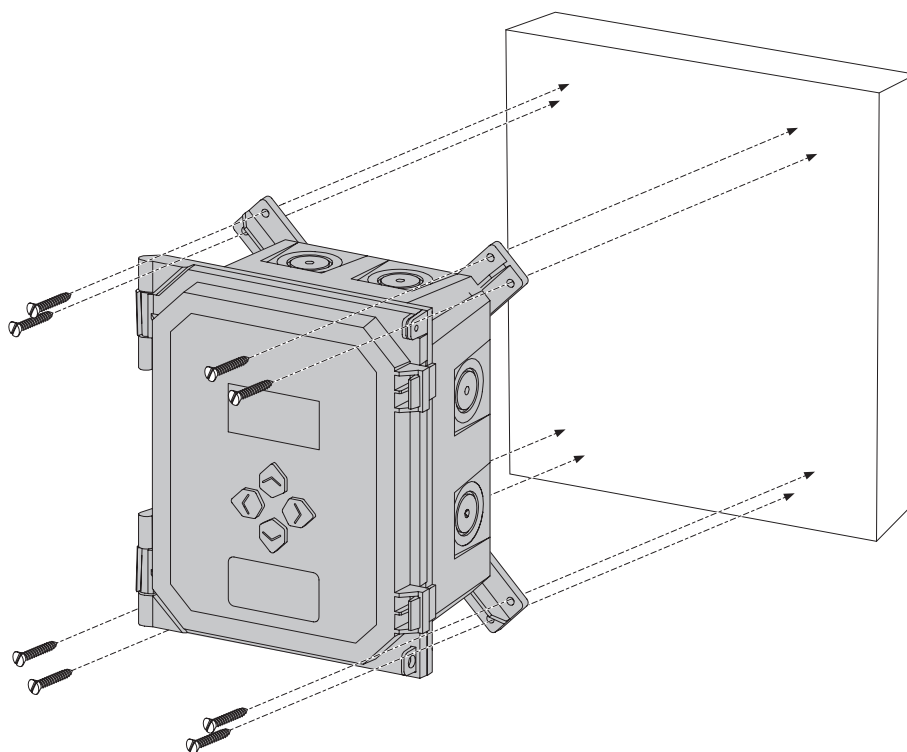

4 INSTALLATION

Flush Mounting:

Using the flush mount kit, attach the flush mount tabs to the enclosure, using the screws provided. The meter is designed to fit into a cutout in standard sheetrock wall of 5.5 in. wide x 7.0 in. tall. The flush mount kit includes the tabs to secure the meter to the wall and a paintable faceplate to cover the front.

1. Remove the toggle anchor from the screw.



2. Thread the screw through the mounting holes of the enclosure.

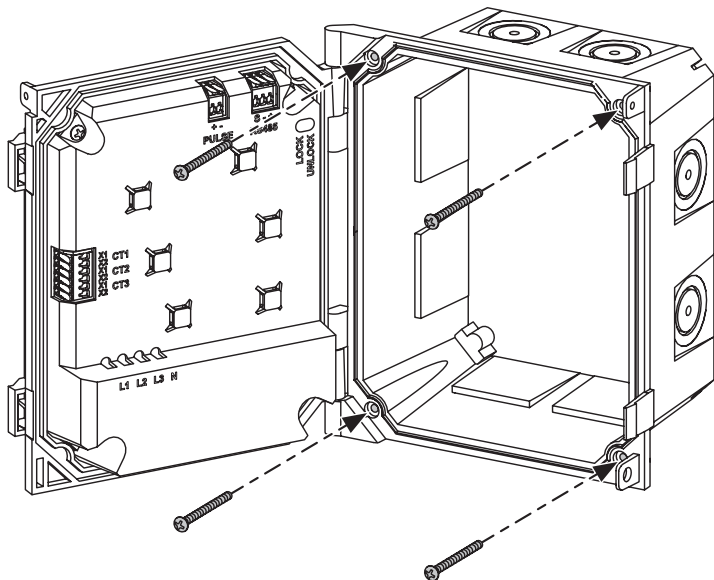

3. Attach the toggle anchor to the screw.

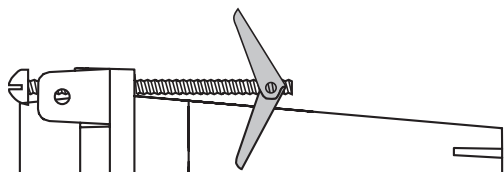

4. Cut out a 5.5 in. wide by 7 in. high section of sheetrock where you want to mount the meter.
5. Insert the meter into the cutout in the wall and turn the screws until the meter is held flush with the wall.
NOTE: Do not overtighten. Minimal force should be required to hold the meter securely in place.
6. Snap the Flush Mount Cover to the front of the meter.
NOTE: This faceplate cover is paintable.

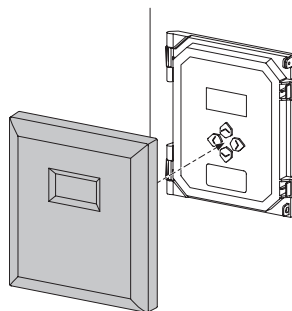
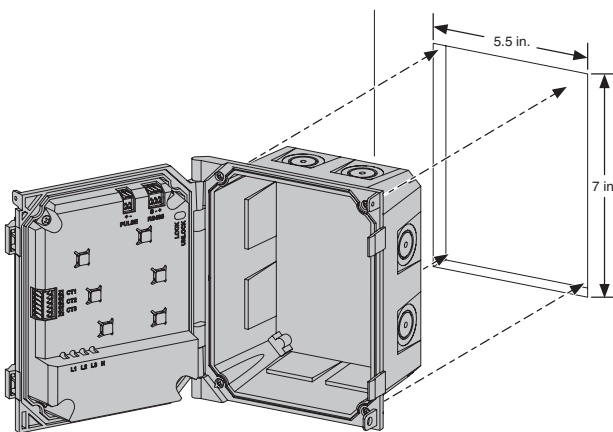

4 INSTALLATION

4.3 Wiring

Connect Voltage Leads:

WARNING: RISK OF ELECTROCUTION, SHOCK, EXPLOSION, OR ARC FLASH. DO NOT ENERGIZE METER WITH VOLTAGE COVER REMOVED. CAREFULLY READ AND FOLLOW INSTRUCTIONS.

1. Connect the voltage leads (L1, L2, L3, and N as necessary) to the meter through a dedicated disconnect or circuit breaker. A voltage lead of 14 AWG THHN minimum 600V AC rating (or equivalent) is required.

NOTES:

- Verify the circuit breaker is marked as the disconnect breaker for the meter.
- The meter is powered from L1 and N, these wires must be connected at minimum.
- Delta (no neutral) service is not supported. Reference voltage must come from the same panel (transformer) source as the circuits being monitored.

The Series 2500 meter comes with flying leads on each of the reference voltage inputs

2. Attach L1 to line 1, L2 to Line 2, L3 to line 3, N to neutral.

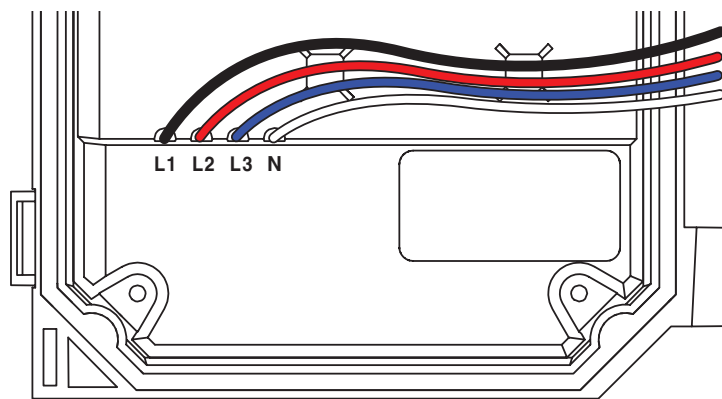
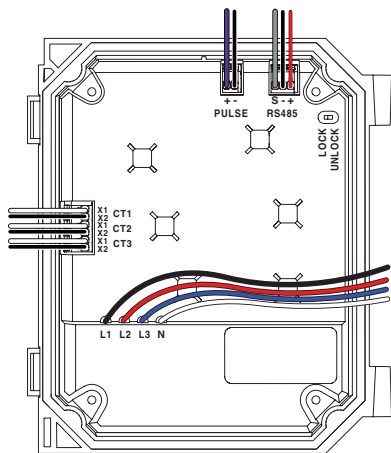

Connect Meter Output Wiring:

Connect the pulse output or Modbus (RS485) wiring to the appropriate meter output terminals at the top of the meter.

1. **Modbus wiring (RS485):** Twisted pair, shielded data cable must be used. Leviton recommends Belden 1120A or equivalent. RS485 is limited to a maximum run length of 4,000 feet. RS485 best practice calls for a 120 ohm termination resistor at each end of the line.

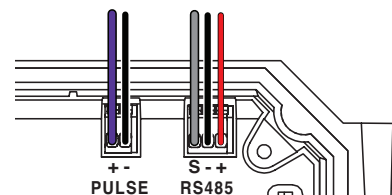

2. **Pulse output wiring:** Stranded 18 to 22 AWG wire is suitable for pulse output wiring. For longer cable runs, heavier gauge wire may prove more reliable. (See Technical Specs for wire types and extension limits)

(See Addendum for wire types and extension limits)

NOTE: There are 6 zip tie anchor points conveniently located on the protective cover to be used as anchors for strain relief and wire management. It is best practice to keep communications wiring separated from high voltage wiring.

Pulse input and RS485 connections are electrically isolated from the CT and voltage input connections.

4 INSTALLATION

Connect Current Transformer Wiring:

1. Attach the current transformer leads to the CT terminals on the meter. They must be connected on the CT input for the matching reference voltage. CT1 corresponds to L1, CT2 corresponds to L2, & CT3 corresponds to L3. (No CT is required for the neutral connection)

Note: CT polarity is critical, so the X1/X2 connections must be correctly connected to the CT +/- output. (see the CT installation guide for specifics)

2. Label the CT wiring prior to pulling it through the conduit to identify each CT and which circuit/phase it is attached to. It is very difficult to identify individual CTs, if they are not properly marked. This is important when working with multi-circuit meters. (Best practice would be to use the breaker position numbers to number the CT leads.)

(See Addendum for CT wire types and extension limits)

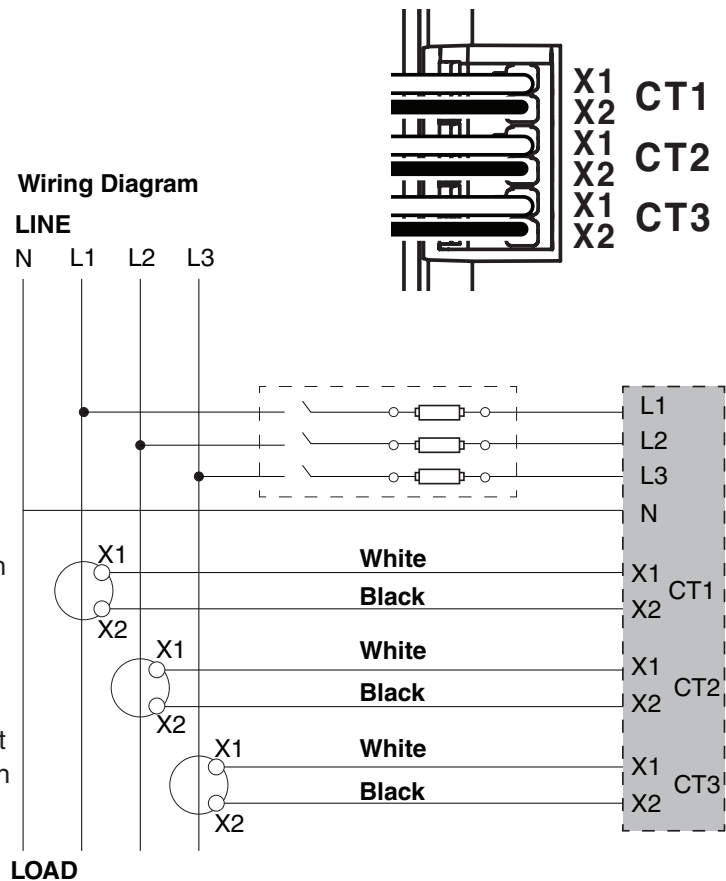

Current Transformers:

To ensure the accuracy of the metering system, use only approved CTs, which have been validated for use with the Series 2500 meter.

- Leviton offers a broad range of approved models, including solid core, split core and Rogowski coil CTs in a variety of sizes and amperage ratings.
- CT orientation is critical. They are marked with indicators showing which side should face line and load. Reversed CTs will provide negative readings to the meter.
- Follow the CT installation guide instructions for proper orientation and wiring.
 - Leviton solid core, split core and Rogowski CTs
 - White wire to X1
 - Black wire to X2
- CTs must be rated for at least the maximum current rating of the circuit being monitored. A CT with a higher current rating than the circuit may be used, but a CT with a rating less than the max rating of the circuit must not be used.



5 CONFIGURING THE METER

The VerifEye® meter has two methods for configuration and data viewing.

1. The meter's front panel user interface, comprised of the LCD and 4 button navigation.
2. The Energy Monitoring Hub (EMH) user interface, which is browser-based and can be accessed with a computer or other browser enabled device.

5.1 Initial Setup - Using the Front Panel Controls & Configuration Wizard

Configuration Menu:

At initial startup, the meter will enter the Config mode wizard, which will guide the user through the basic setup steps. Clicking on the right arrow will enter the setup wizard.



Modbus Address:

Enter the Modbus address for this device. It must be a unique, numeric value between 0 and 247 for the RS485 network it is attached to. The default address is 001. Unless this is the first or only device on the RS485 network, it will need to be changed to a new value.

1. Enter the Modbus setup. Click the right arrow to proceed to the Modbus edit address screen.
2. Use the left and right buttons to move between digits. Use the up and down buttons to change the selected digit to the appropriate value for the Modbus address. With the desired address displayed, click the right arrow to exit the Modbus Address setup and move to the next step.



5 CONFIGURING THE METER

Service Type:

The next step is selecting the service type the meter is being used to monitor. Series 2500 meters are compatible with single-phase 1P/2W, 2P/3W and 3P/4W Wye electrical services from 120VAC to 480VAC. Delta (no neutral) service is not supported.

NOTE: Series 2500 meters do not support Delta service configurations.

There is no default service type selected, requiring the user to select an appropriate service type before the meter will function.

1. Enter the Service Type menu.
Click the right arrow to navigate into the selector.
2. Using the up and down arrows, navigate through the service type selections until the appropriate option is displayed. There are 3 options for service type:
 - 3Ln-n = 3-phase 4 wire Wye
 - 2Ln-n = 2-phase 3 wire Wye
 - 1Ln-n = 1-phase 2 wire Wye
3. With the appropriate option selected, use the right arrow to exit the service type menu to the next step.



5 CONFIGURING THE METER

CT Type:

In order for the meter to properly read the current from the CT (current transformer), the appropriate CT type and amperage must be selected. Unless the meter is properly configured for the attached CT, the readings will not be accurate.

Series 2500 meters are compatible with a variety of solid core, split core, and Rogowski CTs. The Leviton CTs presented in the CT selection menu have been tested and verified for use with these meters. While other 333mV CTs might work, Leviton cannot guarantee the accuracy of the meter with unverified CTs.

- From the CT Type menu, use the right arrow to navigate to the CT selection list.
- Using the up and down arrows, navigate through the CT type selections until the appropriate option is displayed. The list will display the part number of the approved Leviton CTs. This part number can be found on the CT as well as on the packaging.

CT Model Number	Specification
CDV01W15	100A Solid Core
CDV02W20	200A Solid Core
CTV01KD0	100A Split Core
CTV01WC9	100A Split Core
CTV02KD0	200A Split Core
CTV02WC9	200A Split Core
CTV04KD1	400A Split Core
CTV04WD5	400A Split Core
CTV08KG1	800A Split Core
GENR100A	Generic 100A CT
GENR200A	Generic 200A CT
GENR400A	Generic 400A CT
GENR800A	Generic 800A CT

1. From the CT Type menu, use the right arrow to navigate to the CT selection list.

2. Using the up and down arrows, navigate through the CT type selections until the appropriate option is displayed. The list will display the part number of the approved Leviton CTs. This part number can be found on the CT as well as on the packaging.

3. With the appropriate option selected, use the right arrow to exit the CT selection menu and save the configuration settings.



5 CONFIGURING THE METER

4. With the Save Change menu displayed, hold the right arrow button for 3 to 5 seconds to save the changes. When the button is released, the screen will blink and display the Input Saved message.



5. The basic configuration is set and the meter should now display the current kWh readings.



5.2 Meter configuration using the full front panel Settings menus

In addition to the Configuration Wizard, which is intended to help with the initial meter setup, the front panel Settings menus offer a full range of configuration options. These menu options follow the same navigation and flow as the wizard, with access to the full range of configurable settings.

The primary configuration selections required for the meter to function are covered in the configuration wizard, but these same options are also available from the main Settings menu screens.

Following are a number of settings not covered by the configuration wizard, which may need to be adjusted.

1. Modbus

- Address – Default is 1, but this will likely need to be changed to avoid Modbus address conflicts.
NOTE: Every Modbus device on the network must have a unique Modbus address between 1 and 247.
- Baud Rate – Default is 9600, which is appropriate for most applications.
Other settings: 19,200 / 38,400 / 57,600 / 76,800 / 115,200
- Parity – Default setting is none, which is used with other Leviton Modbus devices.
Other settings: even / odd
- Stop Bit – Default is 1, which is used with other Leviton Modbus devices.
Other settings: 2

5 CONFIGURING THE METER

2. Service Type (SERVTYPE) – Setting the reference voltage input configuration for the meter.
- No default setting. This must be configured for the meter to function.
 - Settings: WYE 3P4W (3-phase 4 wire) / WYE 2P3W (2-phase 3 wire) / WYE 1P2W (single-phase 2 wire)

3. CT Type – Define which CTs are being attached to the meter. All CTs must be the same model and rating.

CT options:

CT Model Number	Specification
CDV01W15	100A Solid Core
CDV02W20	200A Solid Core
CTV01KD0	100A Split Core
CTV01WC9	100A Split Core
CTV02KD0	200A Split Core
CTV02WC9	200A Split Core
CTV04KD1	400A Split Core
CTV04WD5	400A Split Core
CTV08KG1	800A Split Core
GENR100A	Generic 100A CT
GENR200A	Generic 200A CT
GENR400A	Generic 400A CT
GENR800A	Generic 800A CT

4. Pulse Output (PULS OUT) indicates the value represented by each pulse.

- Default is 1000 = 1kWh
- Other settings: 10 = 10 Wh (0.001 kWh) / 100 = 100 Wh (0.01 kWh)

5. Demand – The demand interval can be set in increments from 1 minute to 60 minutes.

- Demand interval options: 1 min / 5 min / 15 min / 30 min / 60 min

The following flow chart shows the full set of menu options and the navigation flow chart between the various menus.

5 CONFIGURING THE METER

BASIC METER MENU STRUCTURE/FLOW

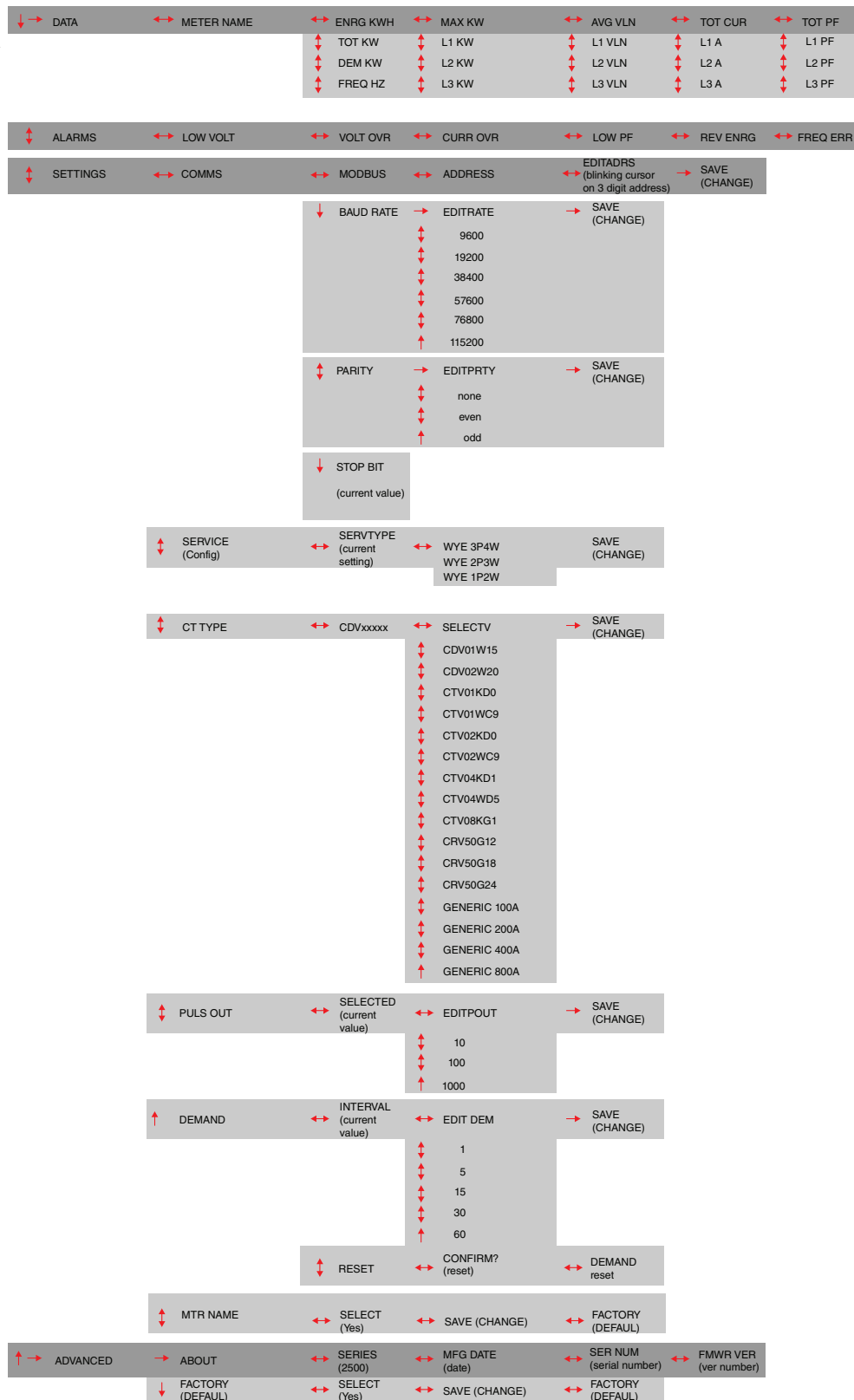

6 CONFIRMING THE INSTALLATION AND CONFIGURATION

6.1 What to do if...

Following is a summary of several troubleshooting tips to help confirm the meter is configured and operating as expected.

Basics

With the meter installed and operating:

1. Confirm the meter is powered and the LCD is on.
2. Confirm the wiring connections are properly attached to the meter. See the Meter Installation section for wiring details.
3. Confirm the CTs are properly installed on the appropriate circuit and there is a sufficient load on the circuit for the meter to sense the load. (min 2% of the rated CT value)
 - Double check CT orientation for line/load.

Configuration Settings

Scrolling through the LCD screens is an easy way to validate the meter configuration settings. This may be done either by using the setup wizard, or simply by navigating through the various menu options.

The critical settings are:

1. Modbus Address: Every device in a Modbus network must have a unique address between 0 and 247. The factory default setting is 1
2. Service Type: The meter must be configured to match the electrical service being monitored, which may be a single-pole, 2-pole, or 3-pole load. The meter can sense the voltage input, but it must be configured for the appropriate number of CT inputs to match the circuit.
3. CT Type & Rating: A variety of CTs are available for use with the meter. In order for the meter to provide accurate readings, the appropriate CT must be selected from the CT selection menu. The menu options list the Leviton CT part numbers. Select the part number matching the CTs being used.

Live Readings

The LCD readings of the live values are also a good way to validate the meter functions.

From the main Data menu, use the front panel buttons to scroll through the various readings, which follow the basic navigation outlined on the next page.

6 CONFIRMING THE INSTALLATION AND CONFIGURATION

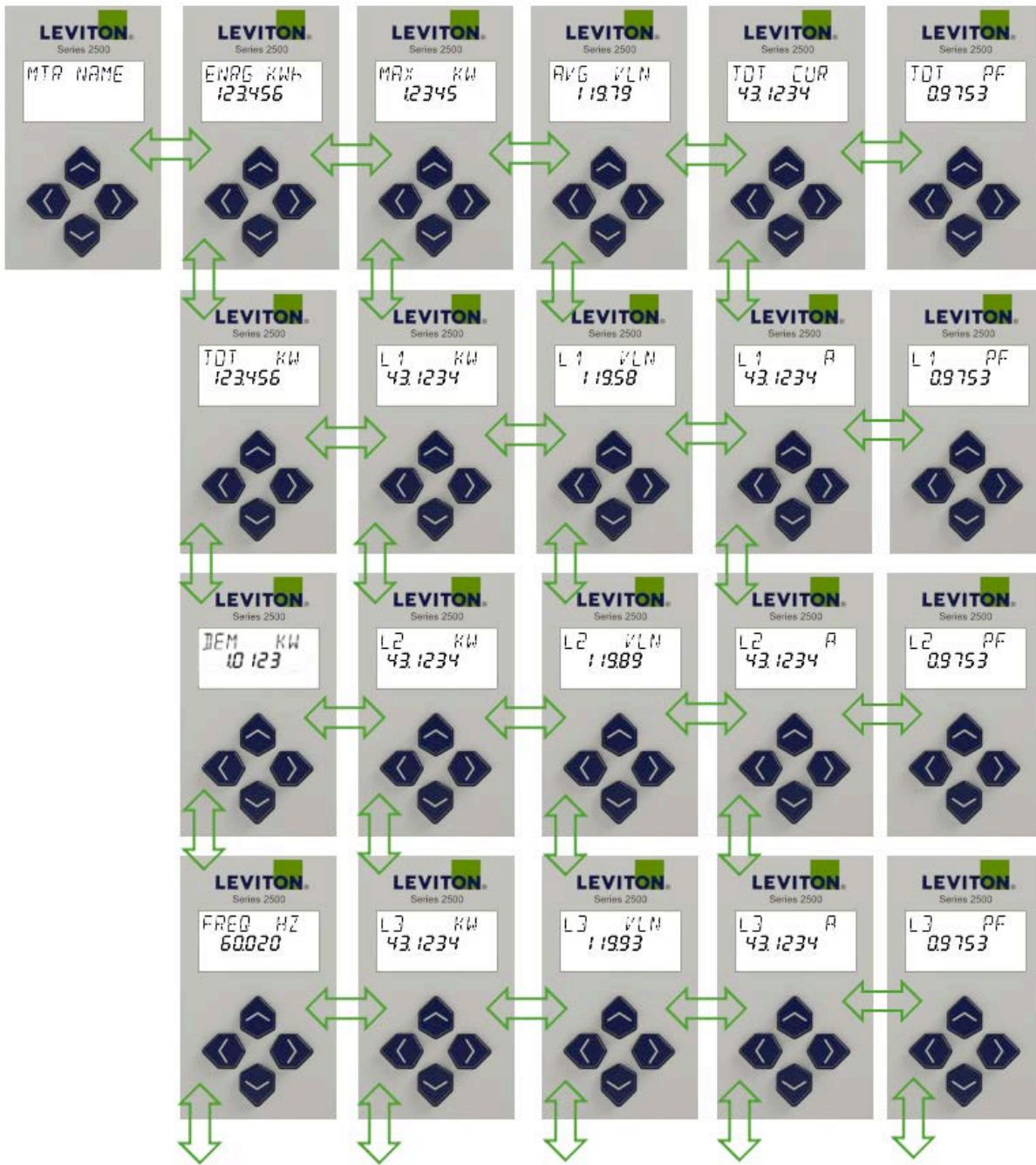

6 CONFIRMING THE INSTALLATION AND CONFIGURATION

Alarms

The meter provides a series of alarms functions to highlight several key parameters, which may have reported values outside the normal operating tolerances of the meter. When an alarm condition occurs, it will be noted by the alarm (bell) icon on the front panel. View the alarms from the Alarms menu options: (Low Voltage, Over Voltage, Low Power Factor, Reverse Energy, Frequency Error, Firmware Error).

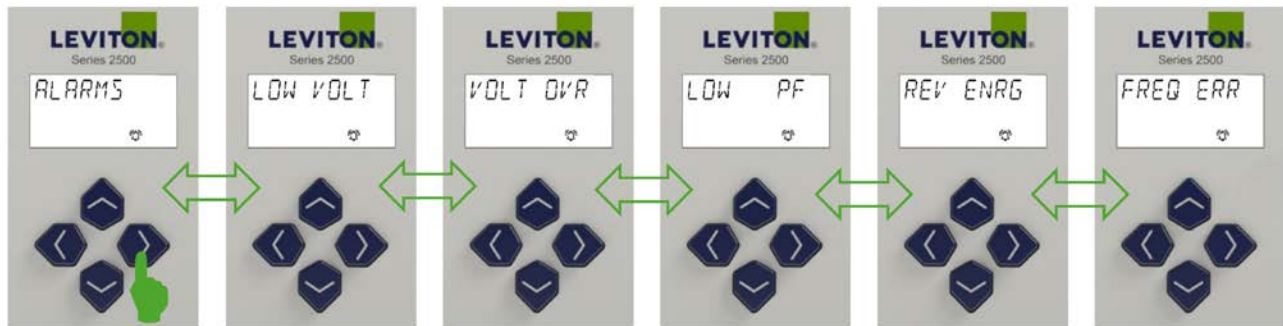

Lock / Unlock - Sealing the Meter

In the upper right corner is a small switch labeled Lock / Unlock. This switch is used to lock the meter, after it has been configured, preventing any of the configuration settings from being changed. The default is unlocked. Switching to the locked position will prevent configuration changes, either from the front panel or through the Modbus RS485 port.

This feature is typically used in situations where there are requirements to seal the meter for billing use. When the meter must be “sealed” after installation, setting this switch to the locked position and placing a lock or seal through the tabs on the enclosure will fulfill this requirement.

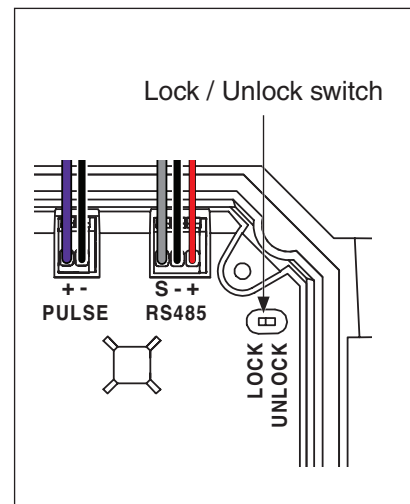

7 TECHNICAL SPECIFICATIONS

MEASUREMENT ACCURACY	
Real Power and Energy	Meets ANSI C12.1, Class 0.2%
Current	0.4% (+0.015% per °C deviation from 25°C) from 5% to 100% of range; 0.8% (+0.015% per °C deviation from 25°C) from 1% to 5% of range
Voltage	0.4% (+0.015% per °C deviation from 25°C) from 90VAC to 277VAC L-N
Data Update Rate	1 sec
INPUT VOLTAGE CHARACTERISTICS	
Measured AC Voltage	This meter is designed to support the following electrical service types: <ul style="list-style-type: none"> • 120/208VAC (120V, L-N) and 277/480VAC, 3-Phase/4 Wire Wye (277V, L-N) • 240VAC, Split-Phase 3 wire (120V, L-N) <p>This meter Does Not support Delta service. (L-L with no Neutral) Minimum 90VL-N for stated accuracy; Maximums: 304VL-N</p>
Input Voltage, Current	120-277VAC, 45mA
Metering Over-Range	+10% (UL Maximums: 304VL-N)
Impedance	2.5 MΩ L-N /5 MΩ L-L
Frequency Range	57 to 63 Hz
INPUT CURRENT CHARACTERISTICS	
CT Scaling	Primary: Adjustable from 100 A to 5,000 A
Measurement Input Range	0 to 0.333 VAC or 0 to 0.350 VAC (+20% over-range), rated for use with Class 1 voltage inputs
OUTPUT	
Real Energy Pulse Contacts	N.O., static output (30VAC/DC, 100mA max. @ 25°C, derate 0.56mA per °C above 25°C) Max pulse output frequency 10 Hz.
RS485 Port	2-wire + shield, 9600 to 115200 baud, Modbus RTU
MECHANICAL CHARACTERISTICS	
Weight	1.5 lb (0.68 kg)
IP Degree of Protection (IEC 60529)	IP14 (NEMA 3R)
Display Characteristics	Back-lit LCD
Terminal Wire Size Reference Voltage	18 AWG (flying leads from the meter)
Pulse Output	24 to 18 AWG
RS485 (Modbus)	24 to 18 AWG (Use only shielded data cable) Belden 1120A recommended
OPERATING CONDITIONS	
Operating Temperature Range	-20° to 70°C (-4° to 158°F)
Storage Temperature Range	-40° to 85°C (-40° to 185°F)
Humidity Range	<95% RH noncondensing
Altitude of Operation	2000 m
COMPLIANCE LISTING	
Agency Listing	UL

8 ADDENDUM

Wiring and Lead Extension

In addition to the specifications below, all cables entering electrical panels must have an insulation rating meeting or exceeding the service voltage. All installations must conform to any applicable electrical and building codes.

CT Wiring Details

CT Wire Extensions: While CT leads may be extended, best practice is to use the shortest length possible. Overall, maximum lead-length allowed for CTs are shown below.

Meter CT Wiring Lengths			
CT Series	CT Output	CTs Max Combined Length	Wire Type
Solid Core CDVxx series Split Core CTVxx series	333mV	200 ft / 60.9 meters	18AWG/20AWG UL1015, 600V, 221° F/105° C, twisted pair black and white
Rogowski Coil CRV50-xxx	70mV/1kA	100 ft / 30.4 meters	Shielded cable with thermoplastic insulation, 600-1000VAC VW-1, 2x24AWG, 105°C, UR listed, Wire Model# RM999F0000000

RECOMMENDED SPLICING METHOD/MATERIALS: (“Bare” Only) Sure-Connect sealed butt splices from McMaster-Carr (p/n 9895K11) which require a crimping tool and hot air gun. Always follow manufacturer’s instructions.

Communications Wiring Details

Modbus Communications Wiring: Follow standard Modbus rules for wiring all Modbus connected devices.

- **Daisy-Chain Configuration:** Modbus devices should be wired in a daisy-chain configuration, with a single data path running from device to device.
- **Total Network Length:** The total cable length of the Modbus network should not exceed 4000 ft (1219 meters).
- **Shielded Twisted-Pair Cable:** Use shielded twisted-pair cable to reduce interference and ensure signal integrity.
- **Impedance:** The cable should have a characteristic impedance of approximately 120 ohms +/- 10%.
- Examples: Leviton recommends Belden 1120A shielded twisted-pair data cable.

Pulse Output Wiring: Use wire or cable rated for the highest voltage present. Pulse output is a simple contact closure circuit with a low voltage and low current signal, so the specific requirements are minimal.

- 2-wire connection.
- 18-24 AWG, 600V, 105°C rated wire
- Leviton recommends 24 AWG purple (+) and gray (-/common) for this application

Communications Cable Type Lengths		
Connection Type	Recommended Wire Type	Max Length
RS485 (Modbus)	Shielded, twisted pair data cable. Belden 1120A or equivalent.	4000 ft / 1219 meters
Pulse Output	18-24 AWG (shielded cable recommended for noisy environments)	200 ft / 60.9 meters

8 ADDENDUM

Modbus Data Point Map

Group	Name	Description	Read/Write	Type	Register Location	# of registers	Applicable Standard	Allowable values	units		
Firmware	Command	reset demand	R/W	unsigned int (16 bits)	1	1	n/a	Hexadecimal 3509	n/a		
		enter FW DL mode						Hexadecimal 539			
		wipe meter						Hexadecimal 1572			
	Meter mode	Standard mode	R	unsigned int (16 bits)	2	1	n/a	Hexadecimal CCCC	n/a		
Firmware update mode		Hexadecimal EEEE									
Global Config	Service Type	3 LN - 1 N	R/W	unsigned int (16 bits)	84	1	n/a	31	n/a		
		2 LN - 1 N						21			
		1 LN - 1 N						11			
	CT Size	Various CT sizes	R	unsigned int (16 bits)	85	1	n/a	100	n/a		
								200			
								400			
								800			
	Global Config	CT Type	enumerated value	R/W	unsigned int (16 bits)	86	1	n/a	CDV01W15 = 0	n/a	
									CDV02W20 = 1		
									CTV5XWA4 = 2		
CTV01KD0 = 3											
CTV01WC9 = 4											
CTV02KD0 = 5											
CRV50G12 = 6											
CTV02WC9 = 10											
CTV04KD1 = 11											
CTV04WD5 = 12											
CTV08KG1 = 13											
CRV50G18 = 14											
CRV50G24 = 15											
GENR100A = 16											
GENR200A = 17											
GENR400A = 18											
GENR800A = 19											
Global Config	CT Name Array	the name of the CT selected by CT type	R	unsigned int (16 bits) array	87	4	n/a	ASCII characters	n/a		
	Subinterval Length	Demand interval	R/W	unsigned int (16 bits)	91	1	n/a	1	minutes		
								5			
								15			
30											
Global Config	Pulse_Weight	wh	R/W	unsigned int (16 bits)	92	1	n/a	50	wH/pulse		
								10			
								100			
Global Branding	MeterModel	model of the meter	R	unsigned int (16 bits) array	93	4	n/a	ASCII characters	n/a		
	MeterSeries	series of the meter								97	4
	MeterBrand	brand of the meter								101	8
	MeterHWDateOfManufacture	date of manufacturer								109	4
	MeterSerialNumberArray	serial number of the meter								113	6
	MeterFWVersion	FW version								119	4
	Reserved	Reserved register		unsigned int (16 bits)	123	1	n/a				
	Reserved	Reserved register						124	1		

8 ADDENDUM

Modbus Data Point Map (continued)

Group	Name	Description	Read/Write	Type	Register Location	# of registers	Applicable Standard	Allowable values	units
Config	Service_Type	3 LN - 1 N	R/W	unsigned int (16 bits)	145	1	n/a	31	n/a
		2 LN - 1 N						21	
		1 LN - 1 N						11	
	Which_Circuit[A]	L1	R/W	unsigned int (16 bits)	146	1	n/a	1	n/a
		L2						2	
		L3						3	
	Which_Circuit[B]	L1	R/W	unsigned int (16 bits)	147	1	n/a	1	n/a
		L2						2	
		L3						3	
	Which_Circuit[C]	L1	R/W	unsigned int (16 bits)	148	1	n/a	1	n/a
		L2						2	
		L3						3	
	CT Size	various CT sizes	R	unsigned int (16 bits)	149	1	n/a	100	n/a
								200	
								400	
								800	
								5000	
	CT Type	enumerated value	R/W	unsigned int (16 bits)	150	1	n/a	CDV01W15 = 0	n/a
								CDV02W20 = 1	
								CTV5XWA4 = 2	
CTV01KD0 = 3									
CTV01WC9 = 4									
CTV02KD0 = 5									
CRV50G12 = 6									
CTV02WC9 = 10									
CTV04KD1 = 11									
CTV04WD5 = 12									
CTV08KG1 = 13									
CRV50G18 = 14									
CRV50G24 = 15									
GENR100A = 16									
GENR200A = 17									
GENR400A = 18									
GENR800A = 19									
Reserved	Reserved register	n/a	unsigned int (16 bits)	151	1	n/a	n/a	n/a	
System_Voltage	This is an auto detect voltage	R	unsigned int (16 bits)	152	1	n/a	typical values 120 to 277	Volts	
Pulse_Weight	wh	R/W	unsigned int (16 bits)	153	1	n/a	10	wH/pulse	
							100		
							1000		
Alerts 0	bit 15 - Frequency error	R	unsigned int (16 bits)	154	1	n/a	0x0000 - 0xFFFF	n/a	
	bit 14 - CT reversal L3								
	bit 13 - CT reversal L2								
	bit 12 - CT reversal L1								
	bit 11 - low PF L3								
	bit 10 - low PF L2								
	bit 9 - low PF L1								
	bit 8 - over current phase L3								
	bit 7 - over current phase L2								
	bit 6 - over current phase L1								
	bit 5 - over voltage phase L3								
	bit 4 - over voltage phase L2								
	bit 3 - over voltage phase L1								
	bit 2 - low voltage phase L3								
bit 1 - low voltage phase L2									
bit 0 - low voltage phase L1									

8 ADDENDUM

Modbus Data Point Map (continued)

Group	Name	Description	Read/Write	Type	Register Location	# of registers	Applicable Standard	Allowable values	units
Config (con't)	Alerts 1	bit 15	R	unsigned int (16 bits)	155	1	n/a	0x0000 - 0xFFFF	n/a
		bit 14							
		bit 13							
		bit 12							
		bit 11							
		bit 10							
		bit 9							
		bit 8							
		bit 7							
		bit 6							
		bit 5							
		bit 4							
		bit 3							
		bit 2							
		bit 1							
	bit 0 - firmware error								
	Reserved	Reserved register	R	unsigned int (16 bits)	156	1	n/a	0x0000 - 0xFFFF	n/a
	Subinterval Length	Demand interval	R/W	unsigned int (16 bits)	157	1	n/a	1 5 15 30 60	minutes
	Power Up Counter	self explanatory	R	unsigned int (16 bits)	158	1	n/a	0x0000 - 0xFFFF	n/a
	Meter locked	self explanatory	R	unsigned int (16 bits)	159	1	n/a	0 - unlocked 1 - locked	n/a
	MeterName	user entered name	R/W	unsigned int (16 bits)	160	4	ASCII characters	ASCII characters	n/a
	CTNameArray	CTs installed	R	unsigned int (16 bits)	164	4	ASCII characters	ASCII characters	n/a
	Reserved	Reserved register	R	unsigned int (16 bits)	168	1	n/a	0x0000 - 0xFFFF	n/a
	Reserved	Reserved register	R	unsigned int (16 bits)	169	1	n/a	0x0000 - 0xFFFF	n/a
	Reserved	Reserved register	R	unsigned int (16 bits)	170	1	n/a	0x0000 - 0xFFFF	n/a
	Reserved	Reserved register	R	unsigned int (16 bits)	171	1	n/a	0x0000 - 0xFFFF	n/a
Comm. Config.	Modbus address	Modbus slave address	R/W	unsigned int (16 bits)	172				
	baud rate	Modbus baud rate	R/W	unsigned int (16 bits)	173				
parity	Modbus parity	R/W	unsigned int (16 bits)	174					
stop bits			R		175	1		1	1 for even or odd parity
								2	2 for no parity
									Auto populates

8 ADDENDUM

Modbus Data Point Map (continued)

Group	Name	Description	Read/Write	Type	Register Location	# of registers	Applicable Standard	Allowable values	units
Data	kWh	total real energy	R	float	304	2	IEEE standard	max per IEEE	kilo-watt hours
	Reserved	reserved register	R	float	306	2	IEEE standard	n/a	n/a
	Total kW	total real power	R	float	308	2	IEEE standard	typical value 0 to 4160	kilo-watt
	Total PF	total power factor	R	float	310	2	IEEE standard	0 to 1	power factor is unitless
	L1 PF	L1 power factor	R	float	312	2	IEEE standard	0 to 1	power factor is unitless
	L2 PF	L2 power factor	R	float	314	2	IEEE standard	0 to 1	power factor is unitless
	L3 PF	L3 power factor	R	float	316	2	IEEE standard	0 to 1	power factor is unitless
	Reserved	reserved register	R	float	318	2	IEEE standard	typical value 0 to 470	volts
	Average VLN	Average line to neutral voltage	R	float	320	2	IEEE standard	typical value 0 to 277	volts
	L1 VLN	L1 line to neutral voltage	R	float	322	2	IEEE standard	typical value 0 to 277	volts
	L2 VLN	L2 line to neutral voltage	R	float	324	2	IEEE standard	typical value 0 to 277	volts
	L3 VLN	L3 line to neutral voltage	R	float	326	2	IEEE standard	typical value 0 to 277	volts
	Total I	Total current	R	float	328	2	IEEE standard	typical value 0 to 5000	amps
	L1 I	L1 current	R	float	330	2	IEEE standard	typical value 0 to 5000	amps
	L2 I	L2 current	R	float	332	2	IEEE standard	typical value 0 to 5000	amps
	L3 I	L3 current	R	float	334	2	IEEE standard	typical value 0 to 5000	amps
	Frequency	line frequency	R	float	336	2	IEEE standard	45 - 65	hertz
	Total kW demand	Max real power demand	R	float	338	2	IEEE standard	typical value 0 to 4160	kilo-watt
	Present kW demand	Present real power demand	R	float	340	2	IEEE standard	typical value 0 to 4160	kilo-watt
	L1 kW	L1 real power	R	float	342	2	IEEE standard	typical value 0 to 4160	kilo-watt
	L2 kW	L2 real power	R	float	344	2	IEEE standard	typical value 0 to 4160	kilo-watt
	L3 kW	L3 real power	R	float	346	2	IEEE standard	typical value 0 to 4160	kilo-watt
	Reserved	reserved register	R	float	348	2	IEEE standard	n/a	n/a
	Reserved	reserved register	R	float	350	2	IEEE standard	n/a	n/a
Reserved	reserved register	R	float	352	2	IEEE standard	n/a	n/a	

9 STANDARD STATEMENTS AND WARRANTY

FCC STATEMENT:

This equipment has been tested and found to comply with the limits for a Class A digital device, pursuant to part 15 of the FCC Rules. These limits are designed to provide reasonable protection against harmful interference when the equipment is operated in a commercial environment. This equipment generates, uses, and can radiate radio frequency energy and, if not installed and used in accordance with the instruction manual, may cause harmful interference to radio communications. Operation of this equipment in a residential area is likely to cause harmful interference in which case the user will be required to correct the interference at his own expense.

FCC SUPPLIER'S DECLARATION OF CONFORMITY:

Model 25B01 is sold by Leviton Manufacturing Inc. 201 N Service Rd, Melville, NY 11747. This device complies with part 15 of the FCC Rules. Any changes or modifications not expressly approved by Leviton Manufacturing Co., Inc., could void the user's authority to operate the equipment. .

Any changes or modifications not expressly approved by Leviton Manufacturing Co., could void the user's authority to operate the equipment.

IC STATEMENT:

This device contains license-exempt transmitter(s)/receiver(s) that comply with Innovation, Science and Economic Development Canada's license-exempt RSS(s). Operation is subject to the following two conditions:

- (1) This device may not cause interference.
- (2) This device must accept any interference, including interference that may cause undesired operation of the device.

TRADEMARK DISCLAIMER:

Leviton, the Leviton Logo and Verifeye are trademarks of Leviton Manufacturing Co., Inc., registered in the U.S. and other countries. Use herein of third-party trademarks, service marks, trade names, brand names and/or product names are for informational purposes only, are/may be the trademarks of their respective owners; such use is not meant to imply affiliation, sponsorship, or endorsement. Modbus is a trademark of Schneider Electric USA.

Leviton Manufacturing Co., Inc.
201 North Service Road, Melville, NY 11747

Visit Leviton's website at www.leviton.com

© 2025 Leviton Manufacturing Co., Inc. All rights reserved.

Specifications and price subject to change at any time without notice.

FOR CANADA ONLY.

For warranty information and/or product returns, residents of Canada should contact Leviton in writing at **Leviton Manufacturing of Canada ULC** to the attention of the **Quality Assurance Department, 165 Hymus Blvd, Pointe-Claire (Quebec), Canada H9R 1E9** or by telephone at **1 800 405-5320**.

LIMITED 5 YEAR WARRANTY

For Leviton's limited 5 year product warranty, go to www.leviton.com. For a printed copy of the warranty, call 1-800-824-3005.

For Technical Assistance Call: 1-800-824-3005 (USA Only) or 1-800-405-5320 (Canada Only) www.leviton.com