

# Data Logger Models L411, L412 & L461



## DATA LOGGERS

### REGISTER ONLINE NOW!

Activate Your New Product Warranty  
and Qualify for Exciting Giveaways!

Measure Up  
WITH AEMC INSTRUMENTS<sup>®</sup>



Copyright© Chauvin Arnoux®, Inc. d.b.a. AEMC® Instruments. All rights reserved.

No part of this documentation may be reproduced in any form or by any means (including electronic storage and retrieval or translation into any other language) without prior agreement and written consent from Chauvin Arnoux®, Inc., as governed by United States and International copyright laws.

Chauvin Arnoux®, Inc. d.b.a. AEMC® Instruments

This documentation is provided **as is**, without warranty of any kind, express, implied, or otherwise. Chauvin Arnoux®, Inc. has made every reasonable effort to ensure that this documentation is accurate; but does not warrant the accuracy or completeness of the text, graphics, or other information contained in this documentation. Chauvin Arnoux®, Inc. shall not be liable for any damages, special, indirect, incidental, or inconsequential; including (but not limited to) physical, emotional or monetary damages due to lost revenues or lost profits that may result from the use of this documentation, whether or not the user of the documentation has been advised of the possibility of such damages.

# Statement of Compliance

Chauvin Arnoux<sup>®</sup>, Inc. d.b.a. AEMC<sup>®</sup> Instruments certifies that this instrument has been calibrated using standards and instruments traceable to international standards.

We guarantee that at the time of shipping your instrument has met the instrument's published specifications.

**An NIST traceable certificate may be requested at the time of purchase, or obtained by returning the instrument to our repair and calibration facility, for a nominal charge.**

The recommended calibration interval for this instrument is 12 months and begins on the date of receipt by the customer. For recalibration, please use our calibration services.

**Serial #:**

**Catalog #:** ~~2153.52 / 2153.53 / 2153.54~~

**Model #:** L411 / L412 / L461

Please fill in the appropriate date as indicated:

Date Received:

Date Calibration Due: \_\_\_\_\_  
\_\_\_\_\_





Chauvin Arnoux<sup>®</sup>, Inc.  
d.b.a AEMC<sup>®</sup> Instruments

---

# TABLE OF CONTENTS

---

<b>1. INTRODUCTION.....</b>	<b>7</b>
1.1 INTERNATIONAL ELECTRICAL SYMBOLS.....	7
1.2 DEFINITION OF MEASUREMENT CATEGORIES (CAT).....	7
1.3 PRECAUTIONS FOR USE  .....	8
1.4 RECEIVING YOUR SHIPMENT .....	8
1.5 PRODUCT PACKAGING .....	9
1.6 ORDERING INFORMATION.....	10
1.6.1 Accessories.....	10
1.6.2 Replacement Parts .....	10
1.7 INSTALLING THE BATTERIES .....	11
<b>2. PRODUCT FEATURES.....</b>	<b>12</b>
2.1 MODEL L411 .....	12
2.2 MODEL L412 .....	13
2.3 MODEL L461 .....	13
2.4 DESCRIPTION .....	14
2.5 FUNCTION BUTTONS.....	14
2.6 LCD DISPLAY .....	15
2.6.1 Status Icons .....	15
2.6.2 Mode Icons .....	16
2.7 MOUNTING .....	16
2.8 EXTERNAL POWER SUPPLY .....	16
<b>3. OPERATION .....</b>	<b>17</b>
3.1 TURNING THE INSTRUMENT ON AND OFF .....	17
3.2 CONFIGURING THE INSTRUMENT .....	18
3.2.1 Front Panel.....	18
3.2.2 AC/DC (L461) .....	18
3.2.3 Wi-Fi .....	19
3.2.3.1 Wi-Fi Access Point Connection Procedure .....	19
3.2.3.2 Configuration of the Wi-Fi Router Connection .....	20
3.2.3.3 Configuration of the DataViewSync™ Connection.....	22
3.2.3.4 Connecting to DataViewSync™ .....	23
3.2.4 Rated Primary Current (Model L411, Model L412) .....	24
3.2.5 Aggregation Period.....	25
3.2.6 Extended Recording Mode.....	25
3.2.7 Reset.....	26
3.3 REMOTE USER INTERFACE .....	26
3.4 INFORMATION .....	29

<b>4. USE</b> .....	<b>32</b>
4.1 CONNECTIONS.....	32
4.1.1 Model L411.....	32
4.1.2 Model L412.....	33
4.1.3 Model L461.....	33
4.1.4 Monitoring a Distribution Panel.....	34
4.1.5 Monitoring at an Outlet.....	34
4.2 STARTING AND STOPPING A RECORDING.....	35
4.3 MEASURED VALUE DISPLAY MODES.....	35
4.3.1 Measurement Mode  .....	35
4.3.2 Maximum Mode  .....	36
<b>5. DATAVIEW® SOFTWARE</b> .....	<b>37</b>
5.1 INSTALLING THE SOFTWARE®.....	37
<b>6. SPECIFICATIONS</b> .....	<b>41</b>
6.1 REFERENCE CONDITIONS.....	41
6.2 ELECTRICAL SPECIFICATIONS.....	41
6.2.1 General.....	41
6.2.2 Model L411.....	41
6.2.2.1 Specific Reference Conditions.....	41
6.2.2.2 Current Measurement Specifications.....	41
6.2.2.3 Current Sensor Thresholds.....	42
6.2.2.4 Frequency Measurement Specifications.....	42
6.2.3 Model L412.....	42
6.2.3.1 Specific Reference Conditions.....	42
6.2.3.2 Specifications of the Current Sensors.....	42
6.2.3.3 Current Sensor Thresholds.....	45
6.2.3.4 Frequency Measurement Specifications on Channel 1.....	46
6.2.4 Model L461.....	46
6.2.4.1 Specific Reference Conditions.....	46
6.2.4.2 DC Measurement Specifications.....	46
6.2.4.3 AC Measurement Specifications.....	46
6.2.4.4 Frequency Measurement Specifications.....	47
6.3 VARIATION IN OPERATING RANGE.....	47
6.3.1 Model L411.....	47
6.3.2 Model L412.....	48
6.3.2.1 Disturbed Signals.....	48
6.3.3 Model L461.....	49
6.4 POWER SUPPLY.....	49
6.4.1 Batteries.....	49
6.4.2 Via USB.....	50
6.5 ENVIRONMENTAL SPECIFICATIONS.....	50











6.6 WI-FI .....	51
6.7 MECHANICAL SPECIFICATIONS .....	51
6.7.1 Model L411 .....	51
6.7.2 Model L412 .....	51
6.7.3 Model L461 .....	51
6.8 COMPLIANCE WITH INTERNATIONAL STANDARDS .....	52
6.8.1 Model L411 .....	52
6.8.2 Model L412 .....	52
6.8.3 Model L461 .....	52
6.9 ELECTROMAGNETIC COMPATIBILITY .....	52
6.10 RADIO EMISSIONS .....	52
6.11 MEMORY .....	52
<b>7. MAINTENANCE .....</b>	<b>53</b>
7.1 CLEANING .....	53
7.2 REPLACING THE BATTERY .....	53
7.3 UPDATING THE FIRMWARE .....	53
7.4 REPLACING THE SD CARD .....	54
7.4.1 Instructions to Replace SD Card .....	54
7.5 MESSAGES .....	55
7.5.1 Main Messages Concerning Wi-Fi .....	55
7.6 REPAIR AND CALIBRATION .....	57
7.7 TECHNICAL SUPPORT .....	57
7.8 LIMITED WARRANTY .....	58
7.8.1 Warranty Repairs .....	58
<b>8. APPENDIX .....</b>	<b>59</b>
8.1 MEASUREMENT FORMULAS .....	59
8.1.1 Aggregation .....	59
8.1.2 Normal Mode .....	59
8.1.3 Extended Mode .....	60

# 1. INTRODUCTION

Thank you for purchasing an AEMC® Instruments Data Logger Model L411, Model L412 or Model L461.

For best results from your instrument and for your safety, read the enclosed operating instructions carefully and comply with the precautions for use. Only qualified and trained operators should use this product.

## 1.1 INTERNATIONAL ELECTRICAL SYMBOLS

	<b>CAUTION - Risk of Danger!</b> Indicates a <b>WARNING</b> . Whenever this symbol is present, the operator must refer to the user manual before operation.
	Indicates a risk of electric shock. The voltage at the parts marked with this symbol may be dangerous.
	Indicates important information to acknowledge.
	Battery
	Strong Magnet
	Signifies that the instrument is protected by double or reinforced insulation.
	Refers to a Type-B current sensor. Application or withdrawal not authorized on conductors carrying dangerous voltages. Type-B current sensor as per IEC 61010-2-032.
	This product complies with the Low Voltage & Electromagnetic Compatibility European directives.
	In the European Union, this product is subject to a separate collection system for recycling electrical and electronic components in accordance with directive WEEE 2012/19/EU.
	Chauvin Arnoux® and AEMC® Instruments have adopted an Eco-Design approach in order to design this instrument. Analysis of the complete lifecycle has enabled us to control and optimize the effects of the product on the environment. In particular this instrument exceeds regulation requirements with respect to recycling and reuse in accordance with ISO 14040.

## 1.2 DEFINITION OF MEASUREMENT CATEGORIES (CAT)

- CAT IV:** Corresponds to measurements performed at primary electrical supply (< 1000 V).  
*Example: primary overcurrent protection devices, ripple control units, and meters.*
- CAT III:** Corresponds to measurements performed in the building installation at the distribution level.  
*Example: hardwired equipment in fixed installation and circuit breakers.*
- CAT II:** Corresponds to measurements performed on circuits directly connected to the electrical distribution system.  
*Example: measurements on household appliances and portable tools.*

## 1.3 PRECAUTIONS FOR USE

These instruments comply with the following safety standards:

- **Model L411:** IEC/EN 61010-2-032 for voltages up to 600 V in CAT IV or 1000 V in CAT III.
- **Model L412:** IEC/EN 61010-2-30 and current sensors comply with IEC/EN 61010-2-032.
- **Model L461:** IEC/EN 61010-2-30 for voltages up to 1000 Vac in CAT IV or 1500 Vdc in CAT III and the leads comply with IEC/EN 61010-031.

Failure to observe the precautions for use may lead to a risk of electric shock, fire, explosion, and/or destruction of the instrument and of the installations.

- The operator and/or the responsible authority must carefully read and clearly understand the various precautions to be taken in use. Sound knowledge and a keen awareness of electrical hazards are essential when using this instrument.
- **Model L461:** Use only the supplied or specified accessories (voltage leads).
  - When assembling an instrument with leads, alligator clips or power adapter, the nominal voltage for a single measurement category is the lowest of the nominal voltages assigned to the individual components.
  - When connecting a current sensor to a measuring instrument, account must be taken of any potential feedback of voltage from the measuring instrument to the current sensor and therefore of the common mode voltage and acceptable measurement category at the current sensor secondary.
  - When handling leads and alligator clips, do not place fingers beyond the physical guard.
- Before each use, check the condition of the insulation on the leads, housing, and accessories. Any item of which the insulation is deteriorated (even partially) must be set aside for repair or scrapping.
- Do not use the instrument on networks whose voltage or category exceeds those mentioned.
- Do not use the instrument if it seems to be damaged, incomplete, or poorly closed.
- Use personal protection equipment systematically.
- If the instrument gets wet, dry it before connecting it.
- All troubleshooting and metrological checks must be performed by competent, accredited personnel.

## 1.4 RECEIVING YOUR SHIPMENT

Upon receiving your shipment, make sure that the contents are consistent with the packing list. Notify your distributor of any missing items. If the equipment appears to be damaged, file a claim immediately with the carrier and notify your distributor at once, giving a detailed description of any damage. Save the damaged packing container to substantiate your claim.

## 1.5 PRODUCT PACKAGING

### PRODUCT PACKAGING



Data Logger  
Model L411  
**Cat. #2153.52**



Data Logger  
Model L412  
**Cat. #2153.53**



Data Logger  
Model L461  
**Cat. #2153.54**



\*Adapter - US wall plug  
to USB  
**Cat. #2153.78**



Cable - 6 ft USB Type  
A-Type B Micro  
**Cat. #2138.66**



Set of 2,  
10 ft (3 m) color-coded  
ST/ST leads (red/black)  
**Cat. #5100.29**  
*(Included with L461 Only)*

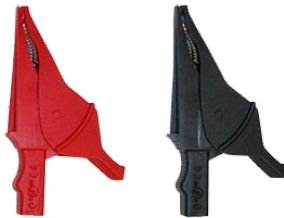

Set of 2, color-coded  
safety alligator clips  
(red/black)  
**Cat. #5000.99 (black)**  
**Cat. #5100.00 (red)**  
*(Included with L461 Only)*

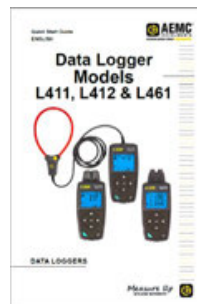

Quick Start Guide

(1) 4 GB USB Drive  
with User Manual &  
Dataview® Software

#### Also Included:

- (3) AA LR6 Alkaline Batteries
- (1) Declaration of Conformity
- (1) Test Report

\*Replacement 5 V, 2 A USB chargers can be purchased from third-party manufacturers.

## 1.6 ORDERING INFORMATION

### Data Logger Model L411

(1-CH, TRMS, w/LCD, 3000 A<sub>AC</sub>, DataView® software)..... Cat. #2153.52

*Includes: Meter with attached MiniFlex® sensor, USB to micro USB cable, US wall plug to USB adapter (2 A, 5 V, 10 W USB-A), (3) AA LR6 alkaline batteries, quick start guide, USB drive with DataView® software and user manual.*

### Data Logger Model L412

(2-CH, TRMS, w/LCD, Current, DataView® software)..... Cat. #2153.53

*Includes: Meter, USB to micro USB cable, US wall plug to USB adapter (2 A, 5 V, 10 W USB-A), (3) AA LR6 alkaline batteries, quick start guide, USB drive with DataView® software and user manual.*

**Data Logger Model L461 (1-CH, TRMS, w/LCD, 1200 VAC/1700 VDC, DataView® software, voltage input for solar panels) ..... Cat. #2153.54**

*Includes: Meter, USB to micro USB cable, US wall plug to USB adapter (2 A, 5 V, 10 W USB-A), Set of 2, 10 ft (3 m) color-coded ST/ST leads, (2) color-coded alligator clips (red/black), (3) AA LR6 alkaline batteries, quick start guide, USB drive with DataView® software and user manual.*

### 1.6.1 Accessories

Multifix (Universal Mounting System) ..... Cat. #5000.44

Pouch - Replacement for small Meters (8.5 x 6.75 x 2.7) in..... Cat. #2117.73

Soft carrying pouch (7.75 x 9.25 x 2.75) in..... Cat. #2119.02

#### **For Model L412**

AC Current Probe Model MN93-BK..... Cat. #2140.32

AC Current Probe Model SR193-BK ..... Cat. #2140.33

AC Current Probe Model MN193-BK (5 A & 100 A<sub>AC</sub>) ..... Cat. #2140.36

AmpFlex® Sensor Model 193-24-BK ..... Cat. #2140.34

AmpFlex® Sensor Model 193-36-BK ..... Cat. #2140.35

MiniFlex® Model MA 193-10-BK ..... Cat. #2140.48

MiniFlex® Model MA 193-14-BK ..... Cat. #2140.50

MiniFlex® Model MA 193-24-BK ..... Cat. #2140.80

AC Current Probe Model MN94..... Cat. #2140.81

#### **For Model L461**

Adapter - 110 V Outlet w/4mm banana plugs..... Cat. #2118.49

### 1.6.2 Replacement Parts

Cable - 6 ft USB Type A-Type B Micro ..... Cat. #2138.66

Adapter - US wall plug to USB ..... Cat. #2153.78

Clip - Safety Alligator-Black (1500 V CAT III or 1000 V CAT IV)..... Cat. #5000.99

Clip - Safety Alligator-Red (1000 V CAT IV, 15 A, UL V2)..... Cat. #5100.00

Lead - Set of 2, 10 ft (3 m) color-coded (red/black) ST/ST banana plug... Cat. #5100.29

**Order Accessories and Replacement Parts Directly Online**

## 1.7 INSTALLING THE BATTERIES

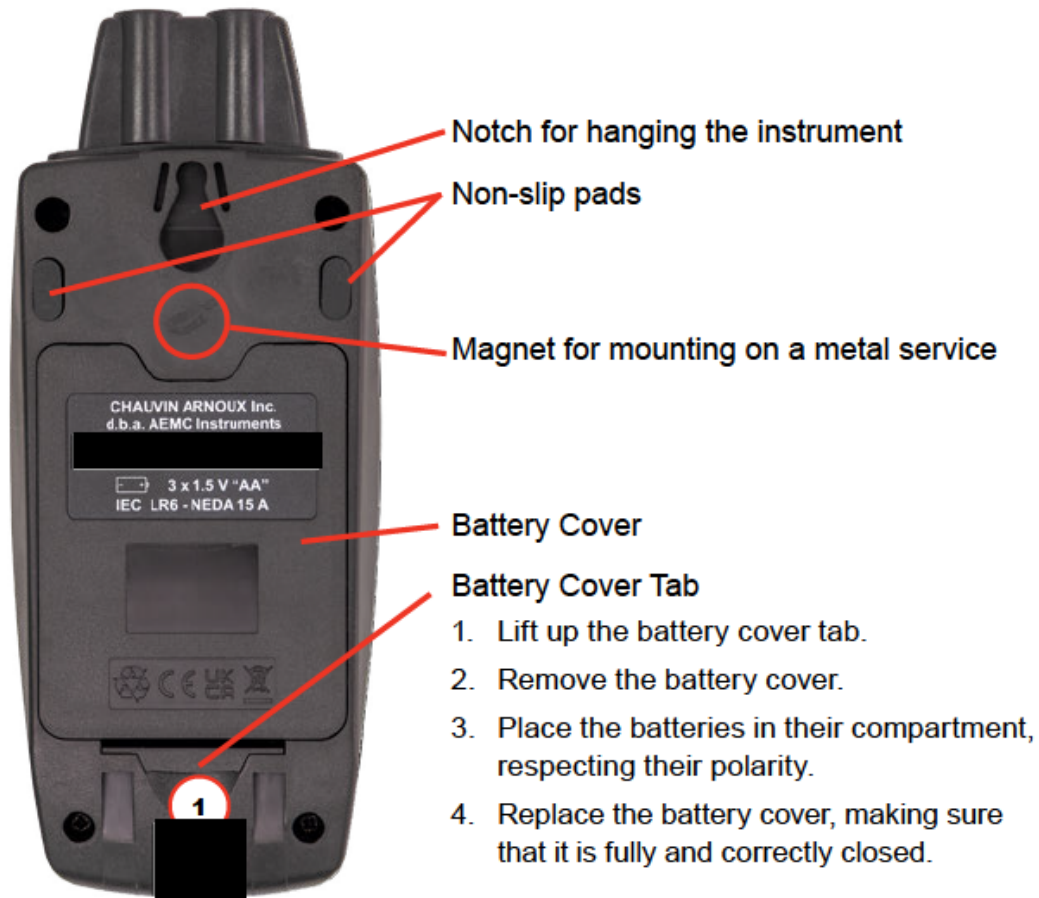

Figure 1



Figure 2

---

## 2. PRODUCT FEATURES

---

### 2.1 MODEL L411

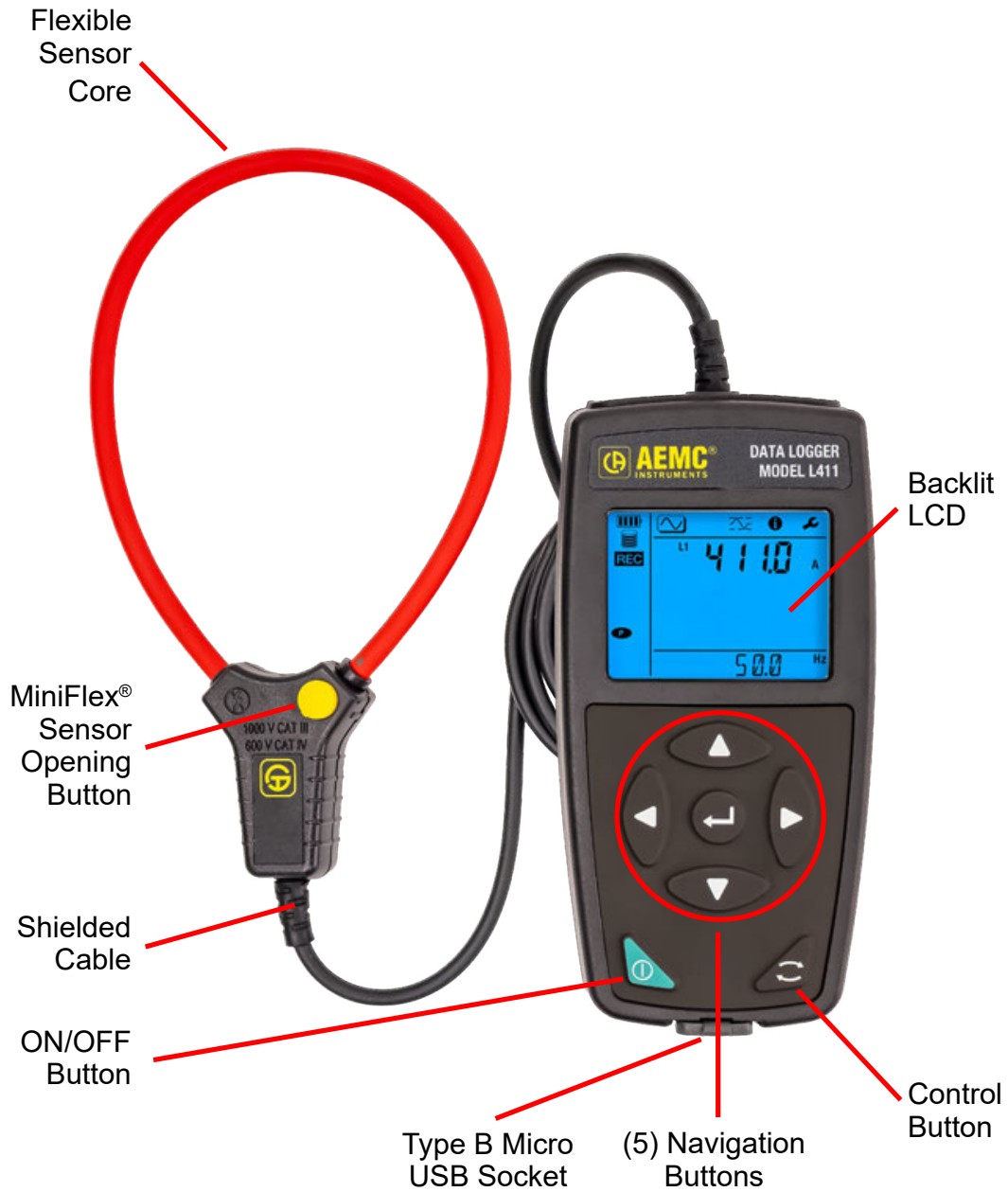

**Figure 3**

## 2.2 MODEL L412



Figure 4

## 2.3 MODEL L461



Figure 5

## 2.4 DESCRIPTION

The Data Logger Models L411, L412 and L461 are single or dual channel data loggers. They are powered by batteries or from the power source via a USB cable. They can record up to 200 recording sessions.

The Model L411 can record AC currents on one channel, from (0.4 to 3600) A<sub>AC</sub>.

The Model L412 can record AC currents on two channels, from 10 mA<sub>AC</sub> to 25,000 A<sub>AC</sub>.

The Model L461 can record AC or DC voltages on one channel, from (10 to 1200) V<sub>AC</sub> and (10 to 1700) V<sub>DC</sub>. It is specifically designed for monitoring distribution and solar PV voltages.

They can communicate with a PC via USB or via Wi-Fi.

## 2.5 FUNCTION BUTTONS





	Description
	<p><b>On/Off Button</b> A long press turns the instrument on or off. The instrument cannot be turned off while a recording is in progress or pending, or when the device is connected to an external power supply.</p>
	<p><b>Control Button</b> This starts or stops a recording or allows the Wi-Fi mode to be chosen.</p>
	<p><b>Navigation Buttons</b> Up, Down, Left &amp; Right Used to configure the instrument and browse the data displayed.</p>
	<p><b>Enter Button</b> In Configuration mode, selects a setting to change. In Select mode, starts or stops a recording. Allows the type of Wi-Fi to be chosen.</p>

Table 1

## 2.6 LCD DISPLAY

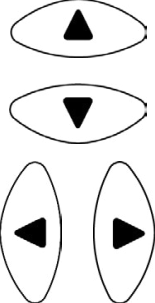
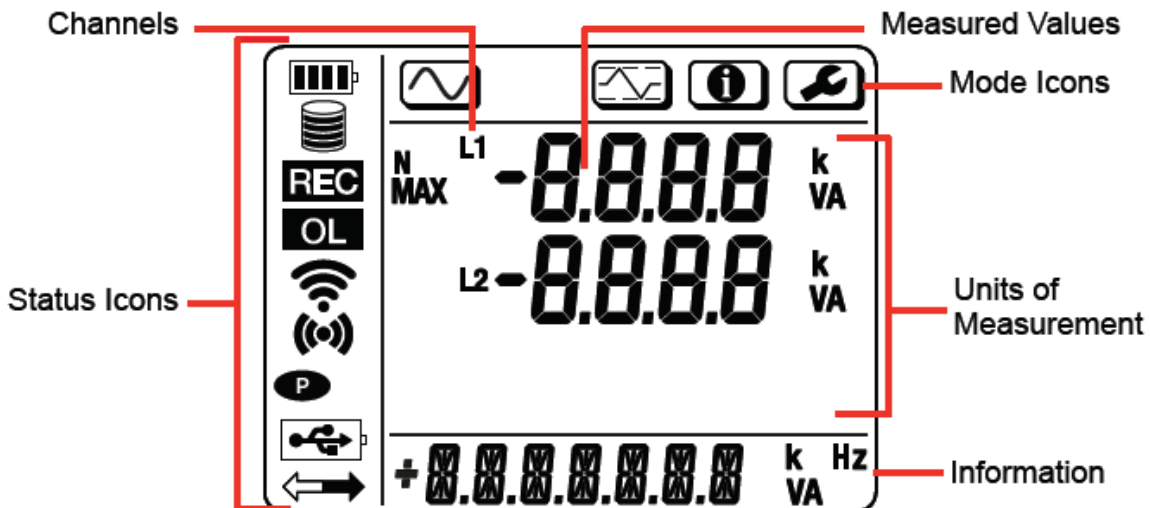

Figure 6

### 2.6.1 Status Icons

Icon	Description
	Indicates battery status. When blinking, batteries need to be changed.
	Indicates memory filling.
	When steady, Normal mode recording is in progress. When blinking slowly (once every 5 seconds), Extended mode recording is in progress. When blinking rapidly (once every 2 seconds), a recording is scheduled.
	Indicates an out-of-range value that cannot be displayed. <b>Model L412:</b> If the indicator is blinking, the two current sensors are not identical.
	Indicates active Wi-Fi at the access point. When blinking, a transmission is in progress.
	Indicates active Wi-Fi at the router. When blinking, a transmission is in progress.
	Indicates the instrument's automatic shutdown function is disabled.
	When on and steady, it indicates that the instrument is powered by USB. When it blinks, the USB link is active.
	Indicates the instrument is being controlled remotely (by a PC, smartphone or tablet).

Table 2

## 2.6.2 Mode Icons





Icon	Description
	Measurement mode
	Maximum mode
	Information mode
	Configuration mode

Table 3

## 2.7 MOUNTING

As recorders, the instruments are intended to be installed for a fairly long period in a technical/mechanical room.

They must be placed in a well ventilated room where the temperature must not exceed the values specified (see § 6.5 Environmental Specifications).

It can be mounted on a flat vertical ferromagnetic surface using the magnets incorporated in its housing.



**WARNING:** The strong magnetic field of the magnets can damage your hard drives or medical devices.

## 2.8 EXTERNAL POWER SUPPLY

The instrument operates on batteries or can be powered through the USB port using a micro USB cable connected to a PC or a wall adapter.

- Open the elastomer cover that protects the micro USB socket.
- Connect the supplied micro USB cable.
- Connect the cable to the supplied USB-AC adapter.
- Plug the adapter into a power outlet.

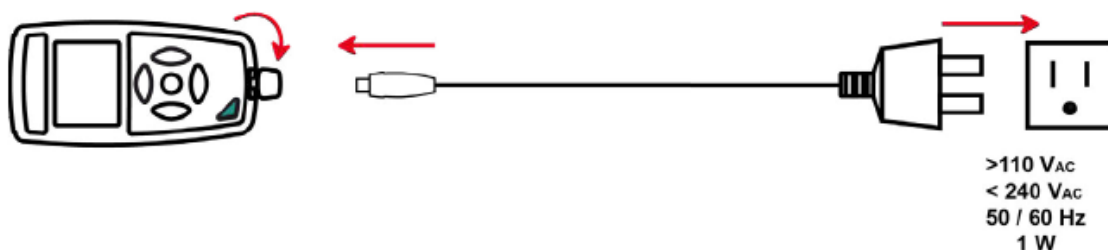

Figure 7

The  icon is displayed.



**NOTE:** Connecting the external power supply does not charge the batteries.

## 3. OPERATION

Before recording the instrument **MUST** be configured. The checkmarks shown in the table below indicates the settings to be configured for each Data Logger model.

	Set Rated Primary Current** (300 / 3000) A 1t or (Sensor dependent)	Select Signal (AC or DC)	Set Wi-Fi* (OFF, On St, or On AP)	Select Aggregation Period (1, 2, 3, 4, 5, 6, 10, 12, 15, 20, 30, or 60)	Choose Type of Recording (Normal or Extended)	Reset to Default
L411	✓	x	✓	✓	✓	✓
L412	✓	x	✓	✓	✓	✓
L461	x	✓	✓	✓	✓	✓

\*Establish a Wi-Fi link with the PC (this link is not essential if you are using a USB link).

\*\*Models L411/L412: See Table 5 for the rated currents of the available compatible current sensors.

**Table 4**

These configurations are made through the instrument in **Configuration mode** (see § 3.2 Configuring Instrument) or through the DataView® Data Logger Control Panel application software (see § 5 DataView®).

To connect the instrument to the PC, you can use the USB link or the Wi-Fi link (to be configured).



**NOTE:** In order to avoid accidental changes, the instrument cannot be configured while recording or if there is a recording pending.

### 3.1 TURNING THE INSTRUMENT ON AND OFF

To start the instrument, press and hold the **ON/OFF**  button. To turn the instrument off, press and hold the **ON/OFF**  button again. The instrument cannot be turned off while a recording is in progress or pending, or when the device is connected to an external power supply.

When the instrument is running on batteries, it turns off automatically after a period with no keypad activity and no recording in progress. The time is set using the Data Logger Control Panel.

It is also possible to switch the instrument to permanent mode, with the Data Logger Control Panel. The icon  is displayed and the instrument no longer turns off.

If there is no action by the user, the instrument switches to standby mode after three minutes, this duration can be programmed at 3, 10 or 15 minutes via the Data Logger Control Panel. It continues to make measurements but they are no longer displayed.

The blue display backlight turns on at startup. It turns off after one minute. It turns on again when a button is pressed or when the USB is connected.

## 3.2 CONFIGURING THE INSTRUMENT

### 3.2.1 Front Panel



Limited functions, show below by model, can be configured directly through the instrument front panel:

- **L411/L412/L461:**
  - set Wi-Fi (OFF, On St, or On AP)
  - set aggregation period (1, 2, 3, 4, 5, 6, 10, 12, 15, 20, 30, or 60)
  - set recording mode (NORMAL or EXTENDED)
  - reset to default
- **L461:** select signal AC or DC
- **L411/L412:** set rated primary current (300 A 1t or 3000 A 1t)



**WARNING:** The date and time cannot be set through the instrument front panel. Connect the instrument to the DataView<sup>®</sup> control panel to set the date and time before first use.

For full configuration use the Data Logger Control Panel (see § 5 DataView<sup>®</sup>).

To enter Configuration mode from the instrument, press the  or  **Navigation** buttons until the  icon is selected.



**NOTE:** If the instrument is already being configured from the Data Logger Control Panel, it is not possible to enter Configuration mode on the instrument. In this case, when an attempt is made to configure it, the instrument displays **LOCK**.

### 3.2.2 AC/DC (L461)

For Model L461, the first screen displayed in Configuration mode is the **Select Signal** screen which allows you to choose between type of signal measured, AC or DC.

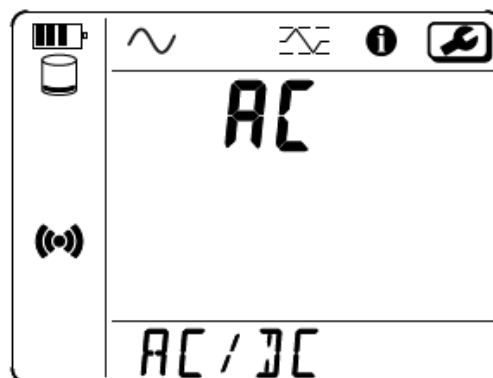



Figure 8

Press the **Enter**  button to switch from AC to DC.

Press the  **Navigation** button to go to the next screen (WIFI).

### 3.2.3 Wi-Fi



**NOTE:** For the Wi-Fi to operate, the battery must be sufficiently charged ( or ), or the instrument must be connected to the external power supply. If the instrument indicates **Battery too low**, then Wi-Fi activation is not possible. Battery charge status can be checked in **Information mode**.

For **Model L411** and **Model L412**, the first screen to appear will be one of the screens shown below in **Figure 9**. This will be the second screen to appear for **Model L461**. These screens allow you to choose between **WIFI OFF**, **WIFI On St** or **WIFI On AP**.

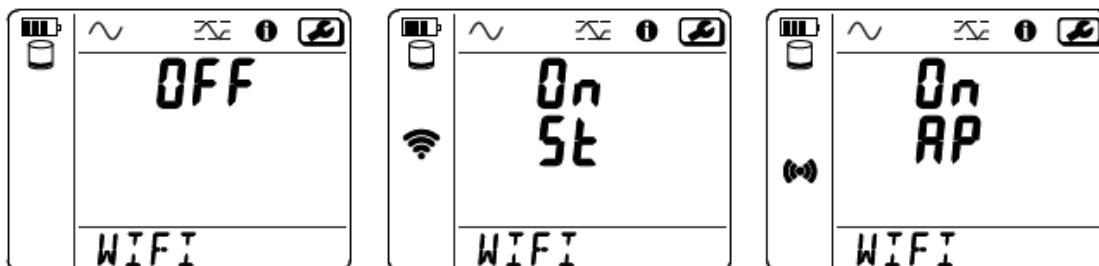

**Figure 9**

Continuously press the button to either activate **On St**, activate **On AP** or deactivate the Wi-Fi (**OFF**).

The Wi-Fi connection allows you to connect to your PC and then to another instrument such as a smartphone or a tablet.

#### 3.2.3.1 Wi-Fi Access Point Connection Procedure

- Press the **Control** button first. The instrument displays **START REC. PRESS ENTER TO START RECORDING.**
- Press the **Control** button a second time and the instrument displays:
  - **WIFI ST. PRESS ENTER FOR WIFI ST,**
  - or **WIFI OFF. PRESS ENTER FOR WIFI OFF,**
  - or **WIFI AP. PRESS ENTER FOR WIFI AP.**

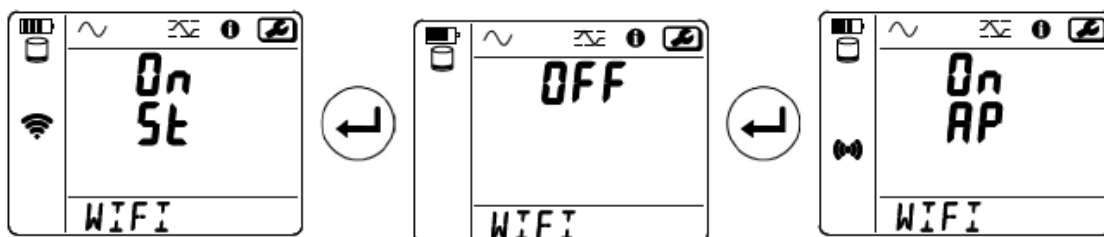

**Figure 10**

Change by pressing the  button to select  **WIFI AP**.

Your instrument's IP address, shown in the information menu, is 192.168.2.1 3041 UDP.

- Connect your PC to the instrument's Wi-Fi.

In the Windows status bar, click the connection icon.

Select your instrument from the list.

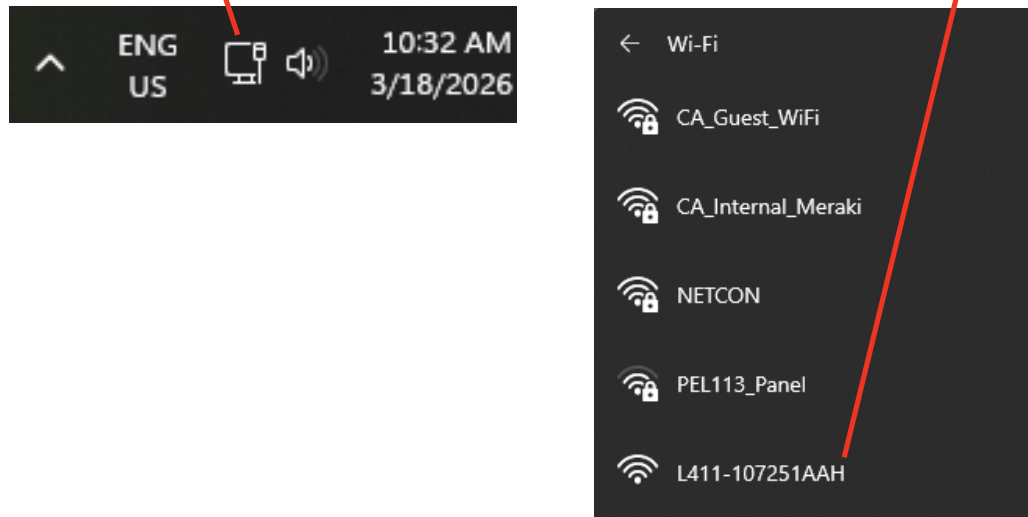

**Figure 11**

- Start the Data Logger Control Panel software application (see § 5 DataView®).
- Go to **Configure Instrument > Instrument > Add an instrument**, then select **L411, L412, or L461 to connect to the Wi-Fi access point**.

This connection to the Data Logger Control Panel software lets you configure the instrument, view real-time measurements, upload recordings, and manage Wi-Fi settings (change and secure the access point SSID, enter network SSID/password, and set the DataViewSync™ password for access to public or private networks).

If the username and password are lost, you can reset the factory configuration (see § 3.2.7 Reset).

### 3.2.3.2 Configuration of the Wi-Fi Router Connection



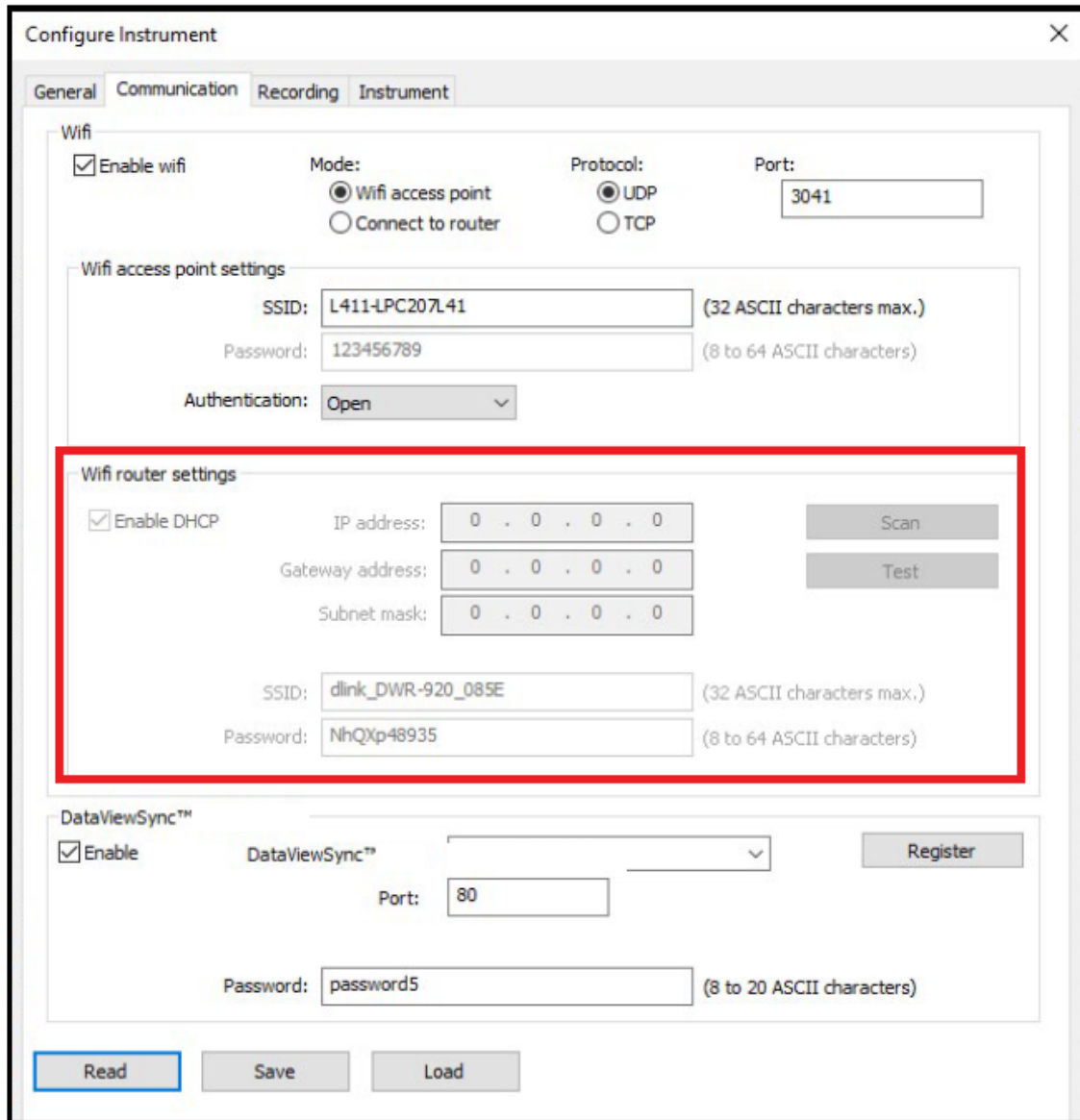

The Wi-Fi router connection will allow you to access your instrument from a smartphone or tablet, or even from DataViewSync™ through a public or private network.

- To do this, connect the instrument to the PC via USB. For security reasons, it is not possible to modify the Wi-Fi connection when you are in Wi-Fi.
- From the Configuration menu , go to **Configure Instrument > Instrument > Add an instrument**. Under **Data Logger**, choose **USB**, select **L411, L412 or L461**, then **confirm**.
- **Instrument, Add an instrument, Data Logger, L411, L412 or L461, in USB**. Select your instrument and confirm.

- In the Data Logger Control Panel, go to **Configure Instrument > Communication**. Enable **Connect to router**, and set Protocol to **UDP** and enter **3041** for Port.
- In the **Wi-Fi router settings** box, enter the network name (SSID) and the password. The SSID is the name of the network you want to connect to. It may be the network of your smartphone or tablet in hotspot mode. Click **Scan** to find networks. Select one, then click **Test** to confirm the connection.
- Click **OK** to confirm.



**Figure 12**

- The instrument automatically switches to  **WIFI ST**. If this does not happen, press the instrument **Control**  button twice, then the **Enter**  button twice to switch to  **WIFI ST**.  
Your instrument connects to this Wi-Fi network.  
The Wi-Fi access point connection is lost.

Once the instrument is connected to the network, you can find its IP address in Information mode .

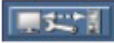

- Connect the PC to the router as explained in Figure 11.
- In the Data Logger Control Panel, change the connection  to **Ethernet (Wifi)** and enter the IP address of your instrument, enter Port **3041** and set Protocol to **UDP**.

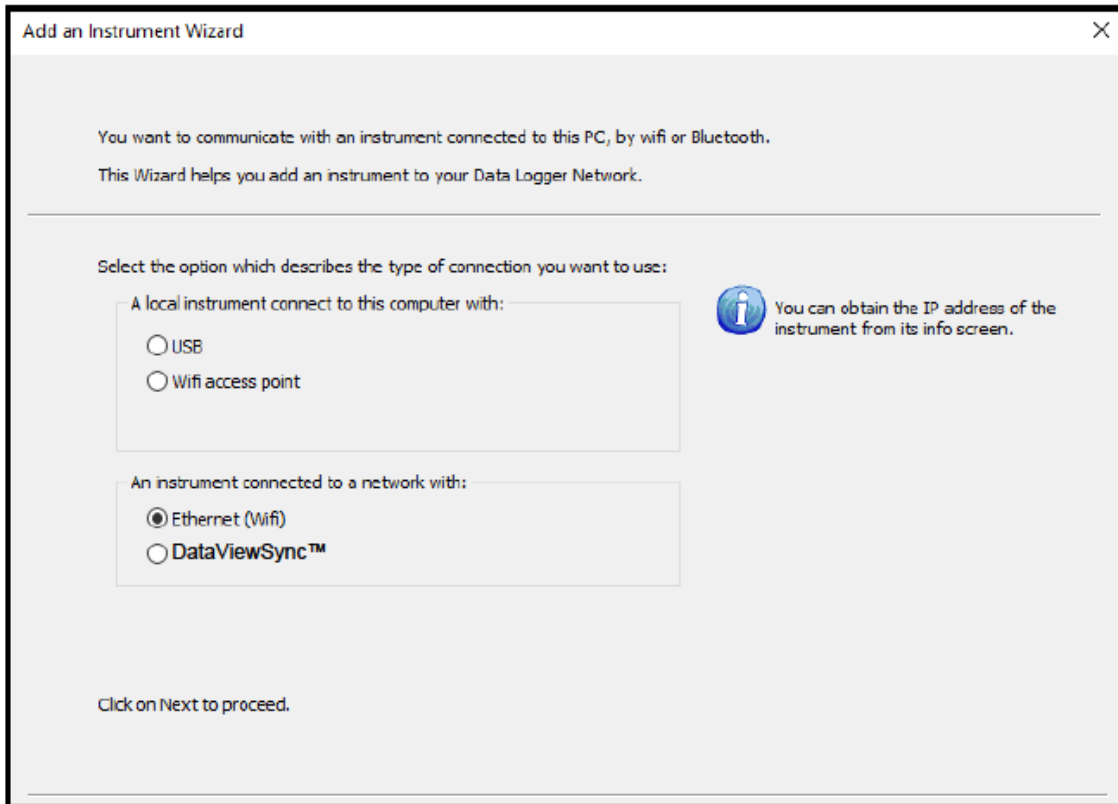
This lets you connect several instruments on the same network.



**Figure 13**

### 3.2.3.3 Configuration of the DataViewSync™ Connection

- To connect the instrument to DataViewSync™ it must be in  **WIFI ST** and the router to which it is connected must have Internet access to be able to access DataViewSync™.
- To configure DataViewSync™, connect the instrument via USB to the Data Logger Control Panel.
- Go to the Configuration menu . Then Go to **Configure Instrument > Communication**. Next **Enable DataViewSync™** and enter the password that will be stored and later used to connect to DataViewSync™.

- Click **Register** to confirm.

The screenshot shows the 'Configure Instrument' dialog box with the following settings:

- Wifi Section:**
  - Enable wifi
  - Mode:  Wifi access point,  Connect to router
  - Protocol:  UDP,  TCP
  - Port: 3041
  - Wifi access point settings:
    - SSID: L411-LPC207L41 (32 ASCII characters max.)
    - Password: 123456789 (8 to 64 ASCII characters)
    - Authentication: Open
  - Wifi router settings:
    - Enable DHCP
    - IP address: 0 . 0 . 0 . 0
    - Gateway address: 0 . 0 . 0 . 0
    - Subnet mask: 0 . 0 . 0 . 0
    - Buttons: Scan, Test
    - SSID: dlink\_DWR-920\_085E (32 ASCII characters max.)
    - Password: NhQXp48935 (8 to 64 ASCII characters)
- DataViewSync™ Section (highlighted in red):**
  - Enable
  - DataViewSync™: [Dropdown menu]
  - Port: 80
  - Password: password5 (8 to 20 ASCII characters)
  - Buttons: Register, Read, Save, Load

**Figure 14**

### 3.2.3.4 Connecting to DataViewSync™

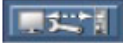
- In the Data Logger Control Panel, change the connection by clicking on the  icon then on **DataViewSync™**.
- Enter the DataViewSync™ address (the same one chosen during setup), the instrument serial number and the password you set in the previous step.
- Click **Next** to confirm.

### 3.2.4 Rated Primary Current (Model L411, Model L412)

Press the  Navigation button to go to the next screen.

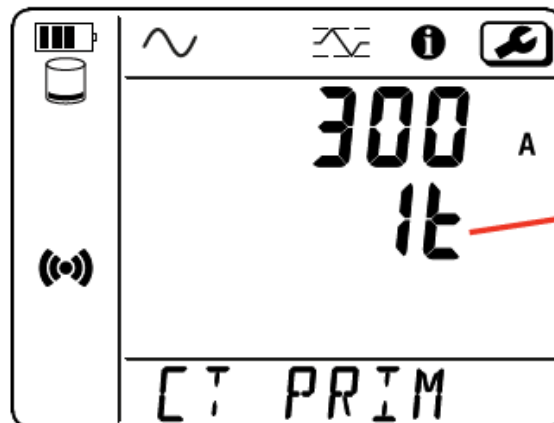

Number of turns the current sensor makes around the conductor. This example displays 1 turn.

Figure 15

For Model L412:

- Connect the current sensor(s).
- The current sensor is automatically detected by the instrument.
- If two current sensors are connected, they must be identical.

For AmpFlex® or MiniFlex® sensors, press the  button to select 300 A or 3000 A.

For the other sensors, configuration is done via the Data Logger Control Panel.

The rated currents of the current sensors are as follows:

Sensor	Rated Current	Choice of Gain	Number of Turns
SR193-BK	1000 A	×	×
AmpFlex® 193-24-BK MiniFlex® MA194-24-BK	300 A or 3000 A	✓	1, 2 or 3 to be configured in Data Logger Control Panel
MN193-BK 5 A	(5 to 25,000) A*	to be configured in Data Logger Control Panel	×
MN193-BK 100 A	100 A	×	×
MN93-BK	200 A	×	×
MN94	200 A	×	×

\* Using a ratio.

Table 5

### 3.2.5 Aggregation Period

Press the  Navigation button to go to the next screen.

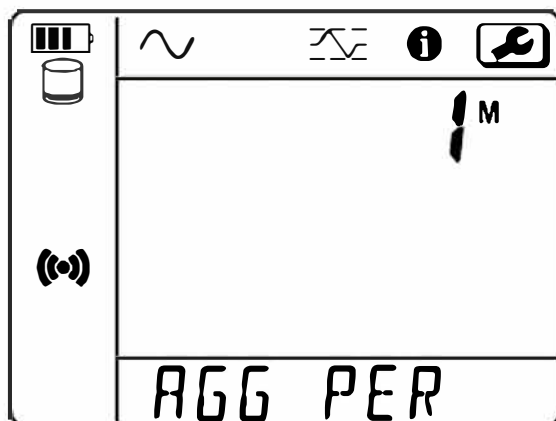



Figure 16

To change the aggregation period, continuously press the  button and stop on the desired option:  
(1, 2, 3, 4, 5, 6, 10, 12, 15, 20, 30 or 60) minutes.

### 3.2.6 Extended Recording Mode

Press the  Navigation button to go to the next screen.

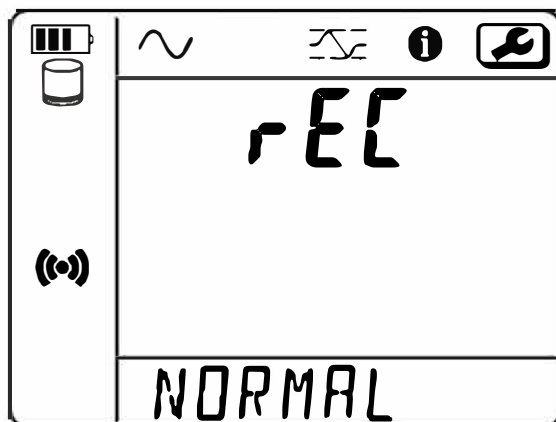



Figure 17

To change the recording mode, continuously press the  button and stop on desired option (NORMAL or EXTENDED).

When the instrument is recording, it may go into standby between two measurements. This can significantly increase its battery life.

In **NORMAL** mode, the instrument is never in standby.

In **EXTENDED** mode, the instrument enters sleep mode and wakes a few seconds before each measurement to record it, without displaying the reading.

In **EXTENDED** mode, the instrument records four measurements per aggregation period instead of one per second. Standby time varies with the aggregation period. This improves battery life but records fewer measurements, which can cause information gaps between readings (see § 8.1.3 Extended Mode).

Press the  button to choose **NORMAL** or **EXTENDED**.

### 3.2.7 Reset

Press the  Navigation button to go to the next screen.

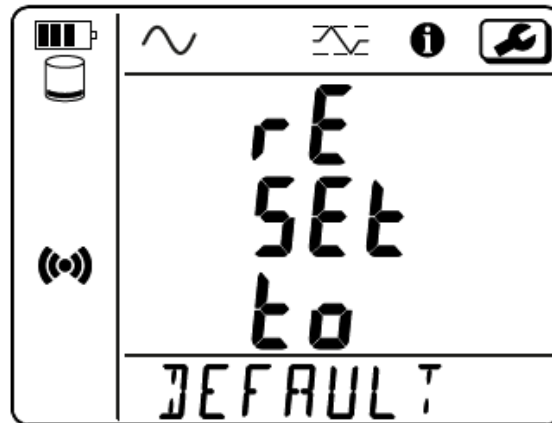



Figure 18





To reset the instrument to the default Wi-Fi configuration (direct Wi-Fi, password deleted), press the  button.

The instrument asks for confirmation before performing the reset. Press the  button to confirm and any other button to cancel.

## 3.3 REMOTE USER INTERFACE

The remote user interface runs on a PC, tablet or smartphone.

It enables:

- consulting the instrument's information,
  - establishing a Wi-Fi router connection,
  - synchronizing date and time,
  - scheduling a recording.
- Enable Wi-Fi on the instrument. The remote user interface can work with an access point Wi-Fi link  or a router Wi-Fi link  but not through DataViewSync™.
  - On a PC, tablet or smartphone, connect as you would to your instrument's Wi-Fi network (see § 3.2.3 Wi-Fi).
  - In a web browser, enter `http://IP_address_instrument`.
  - For a Wi-Fi access point connection , enter `http://192.168.2.1`
  - For a Wi-Fi router connection , the address is indicated in the Information menu (see § 3.4 Information).

The following screen will be displayed (which differs depending on the instrument model):

To enter the SSID and password, click on **Edit**.

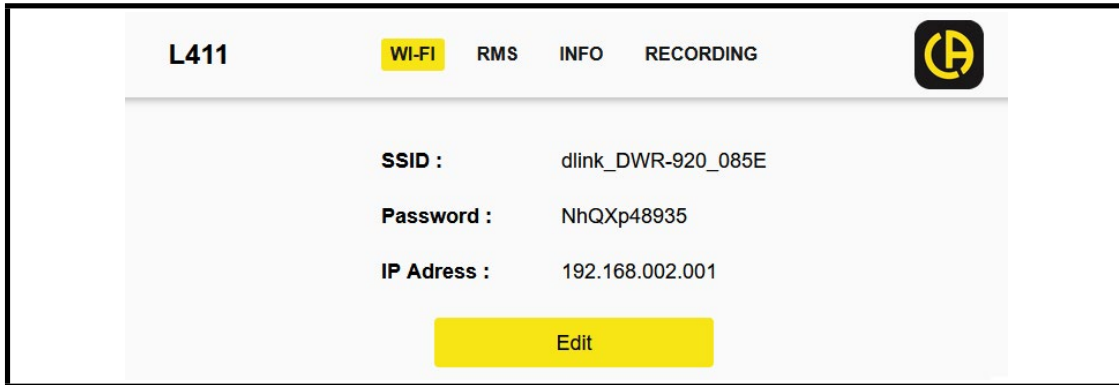

**Figure 19**

Fill in the fields then click on **Submit**.



**Figure 20**

Click on **RMS** to view the measurements.

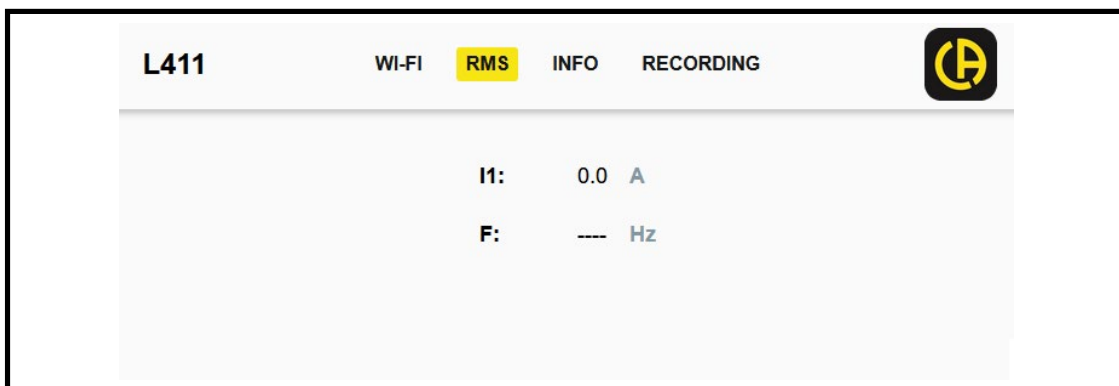

**Figure 21**

Click on **INFO** to view the instrument's Information.

Click on **Synchronize date and hour** to synchronize your instrument's date and time with your PC, tablet or smartphone.

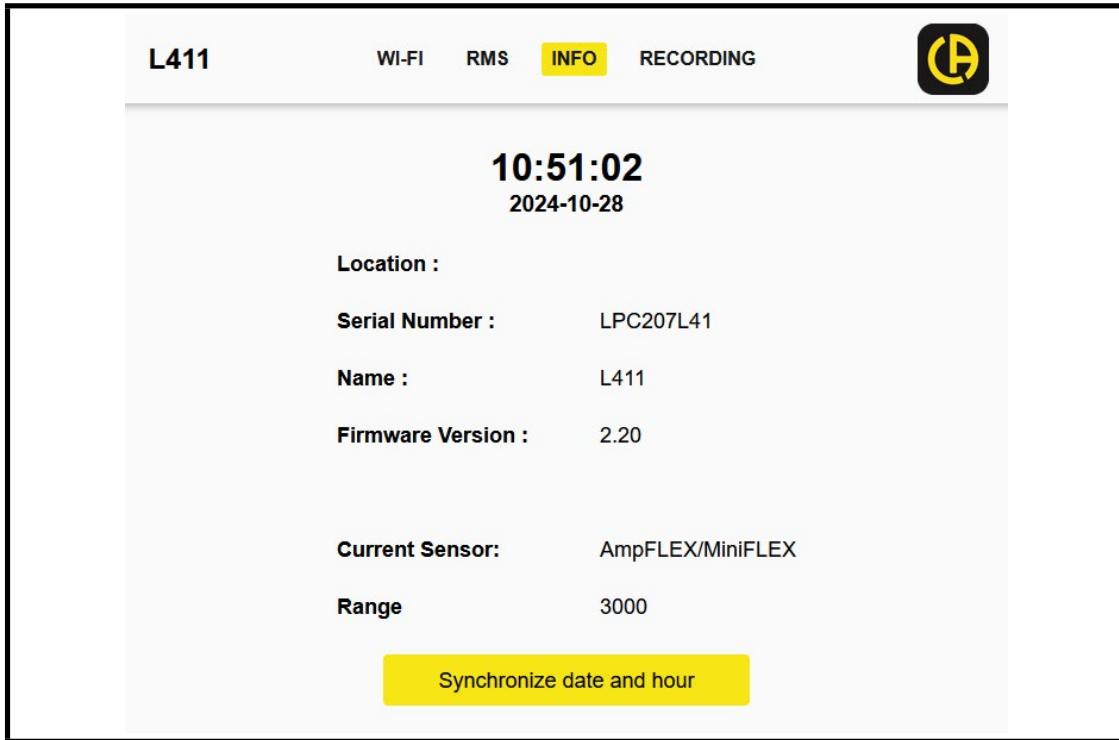

**Figure 22**

Click on **RECORDING** to view information about the current recording or the last recording made.

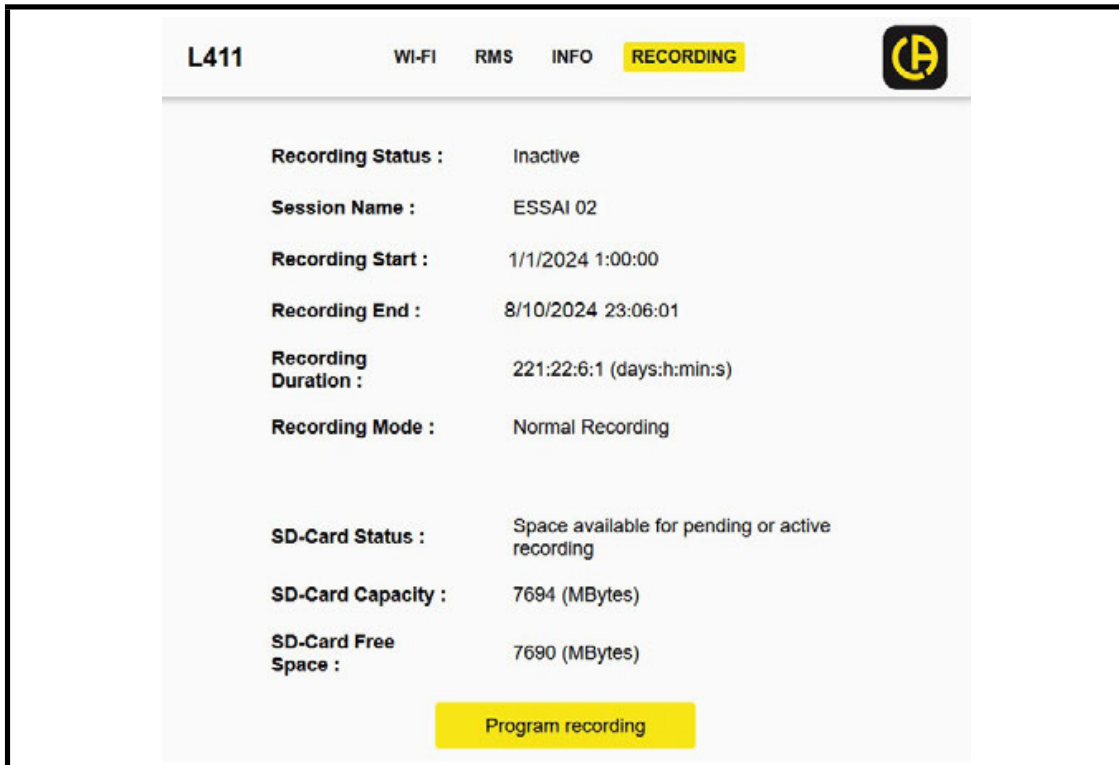



**Figure 23**

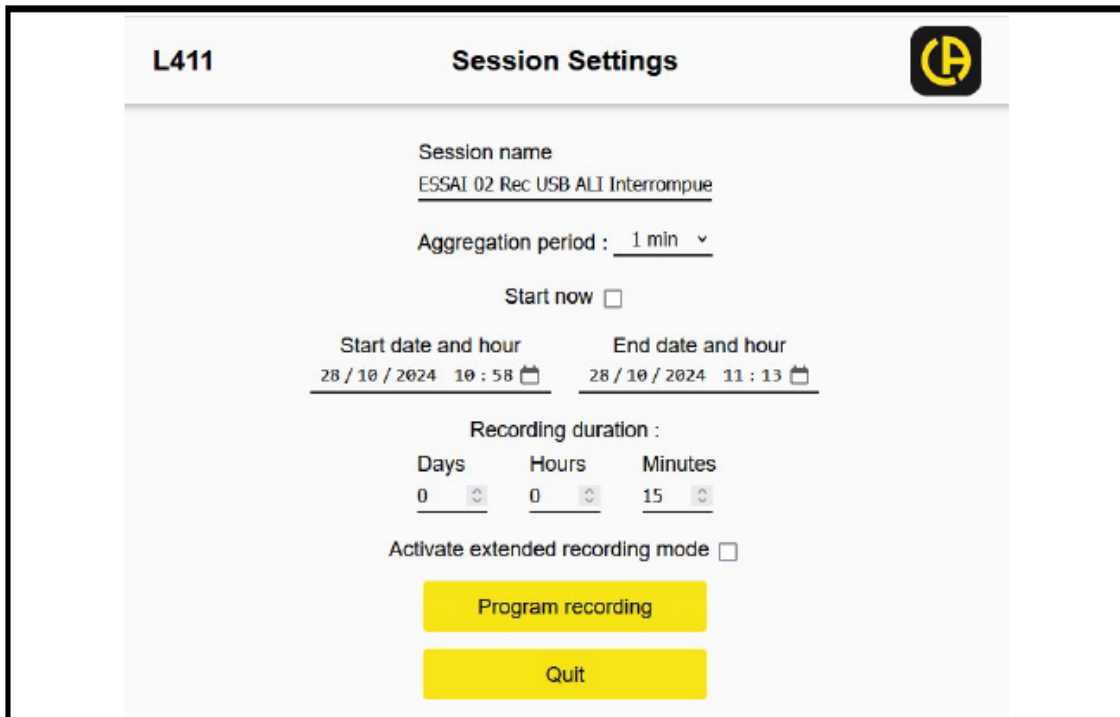

Click on **Program recording** to configure the recording. Click on **Quit** to exit Session Settings.



**Figure 24**

### 3.4 INFORMATION

To enter Information mode, press the  or  **Navigation** buttons until the **Information**  icon is selected.

Then press the  and  **Navigation** buttons to cycle through the instrument Information screens.



**NOTE:** Configuration settings cannot be changed while in Information mode. You must be in Configuration mode to edit settings. See § 3.2 Configuring Instrument.

#### Model L461

- AC/DC Signal Type

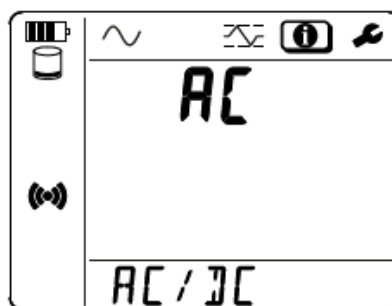

**Models L411 and L412**

- Rated Primary Current

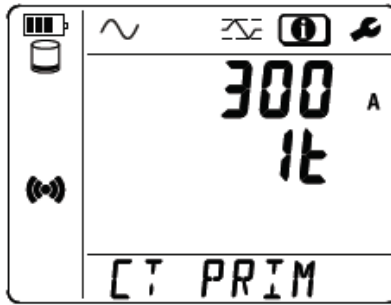

**AEMC® Instruments  
Compatible  
AC Current Probes  
and Sensors**

- SR193-BK: 1000 A
- AmpFlex® or MiniFlex®: 300 A or 3000 A
- MN193-BK: 5 A  
Range: 5 A changeable
- MN193-BK: 100 A  
Range: 100 A
- MN93-BK: 200 A
- MN94: 200 A

- Aggregation Period

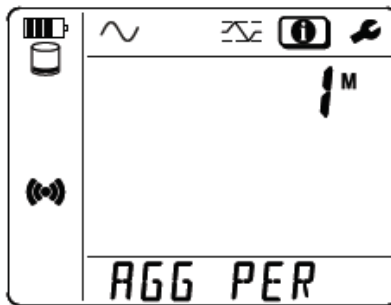

- Recording Type  
Normal or Extended

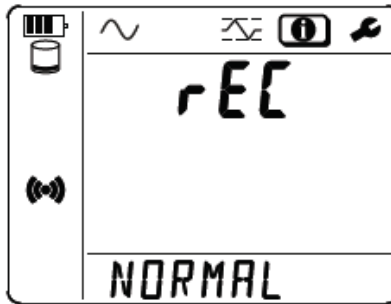

- Date  
Year, Month, Day

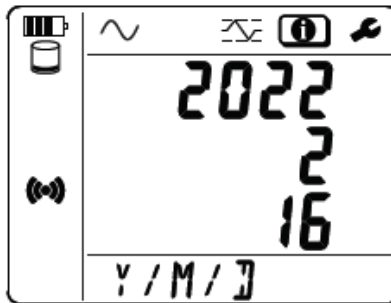

- Time  
Hour, Minute, Second

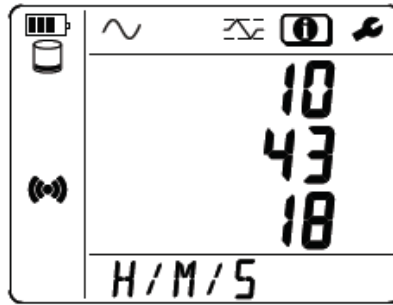

- Battery Voltage

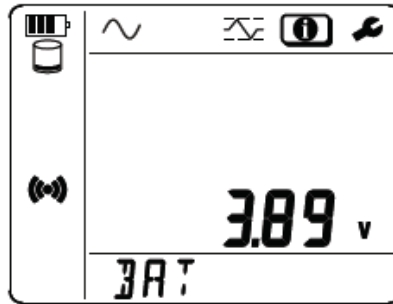

- IP Address (scrolling)

If Wi-Fi is activated, instrument scrolls the IP address, port, and network delivery method.

Example: 192.168.2.1 3041 UDP

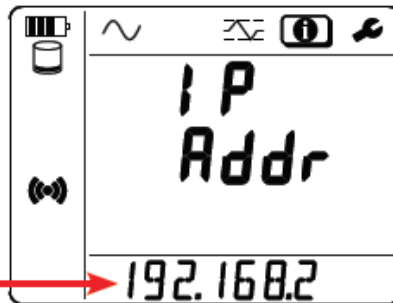

If Wi-Fi is deactivated, instrument scrolls WIFI OFF.

- Software Version and serial number (scrolling)

Instrument scrolls software version and serial number.

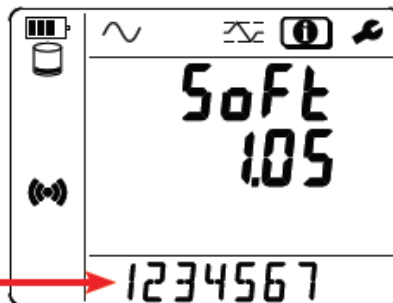

Table 6

---

## 4. USE

---

Once the instrument has been configured, it is ready for use.

### 4.1 CONNECTIONS

---



**NOTE:** When you make connections to live networks, in particular Type-B (AC/DC capable) current sensors, you **MUST** use personal protective equipment for your safety.

---

Current clamps and flexible current sensors are used to measure the current flowing in a cable without opening the circuit. They also isolate the user from dangerous voltages present in the circuit.

The choice of the current sensor to use depends on the current to be measured and the diameter of the cables.

When installing current sensors, point the arrow on the sensor towards the load.

When a current sensor is not connected, the instrument displays - - - -.

#### 4.1.1 Model L411

1. Press the sensor opening button.
2. Wrap sensor around the cable to be measured. The cable should be centered inside the sensor as much as possible.
3. Snap sensor back into it's closed position. A **click** will confirm that it is closed correctly.

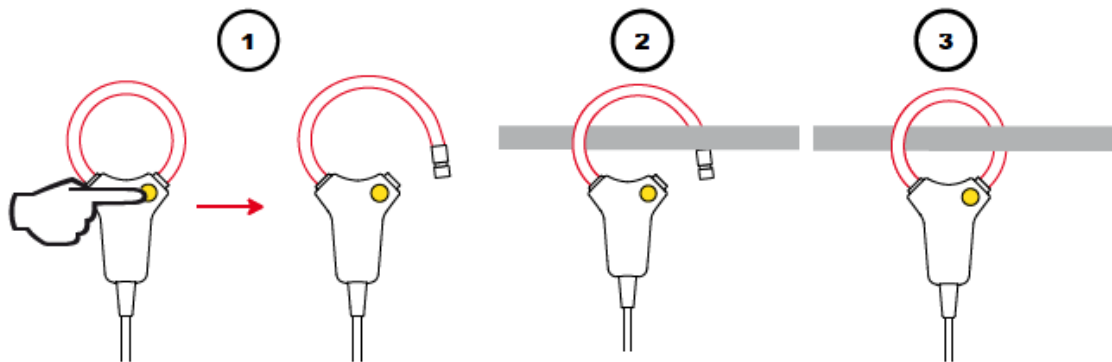

**Figure 25**

4. To remove the sensor, press the sensor opening button. Remove the sensor from the cable and again snap the sensor back into it's closed position.

### 4.1.2 Model L412

- Connect the first current sensor to the instrument's terminal I1.
- If applicable, connect the second current sensor to instrument's terminal I2.



**NOTE:** If two current sensors are connected, they must be identical.

- Press the clamp tab to open the clamp's jaws.
- Then clamp around the cable to be measured. The cable should be centered inside the clamp jaws as much as possible.
- The arrow on the clamp housing should point in the assumed direction of current.
- Release the tab and make sure the jaws are properly closed.

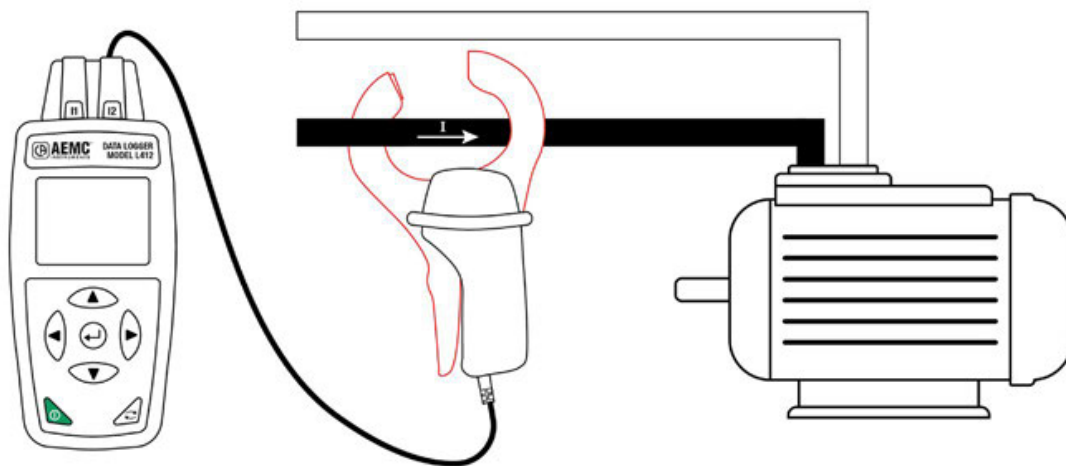

**Figure 26**

### 4.1.3 Model L461

- Connect the black safety lead to the **COM** terminal.
- Connect the red safety lead to the **+** terminal.
- Connect the leads to the voltage to be measured.

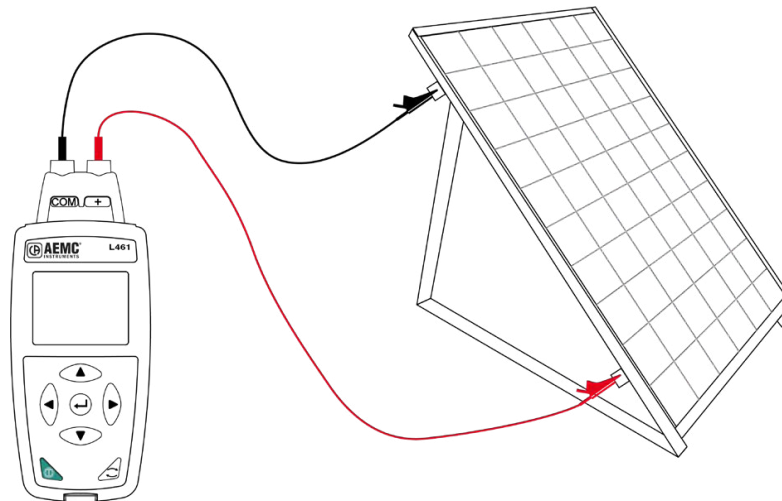

**Figure 27**

#### 4.1.4 Monitoring a Distribution Panel

Ensure the circuit being monitored does not exceed the rated input voltage of the instrument.

- Connect the black safety lead to the **COM** terminal.
- Connect the red safety lead to the **+** terminal.
- Connect the leads to the voltage points to be monitored (e.g., line-to-neutral or line-to-line at the breaker terminals).

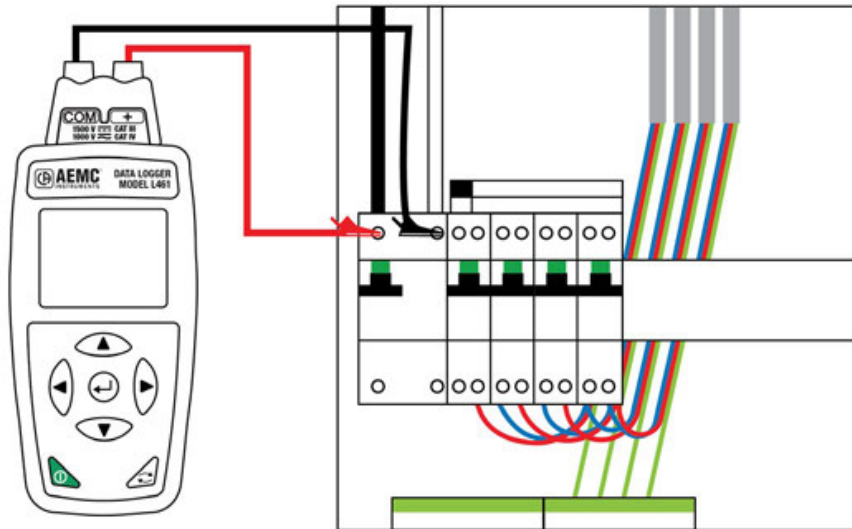

Figure 28

#### 4.1.5 Monitoring at an Outlet

Ensure the outlet voltage does not exceed the rated input voltage of the instrument.

- Connect the banana plugs of accessory Cat. 2118.49, Plug-to-Banana Adapter, to the **+** and **COM** terminals of the instrument (red to **+**, black to **COM**).
- Insert the bladed plug end of the adapter into the outlet to be monitored.

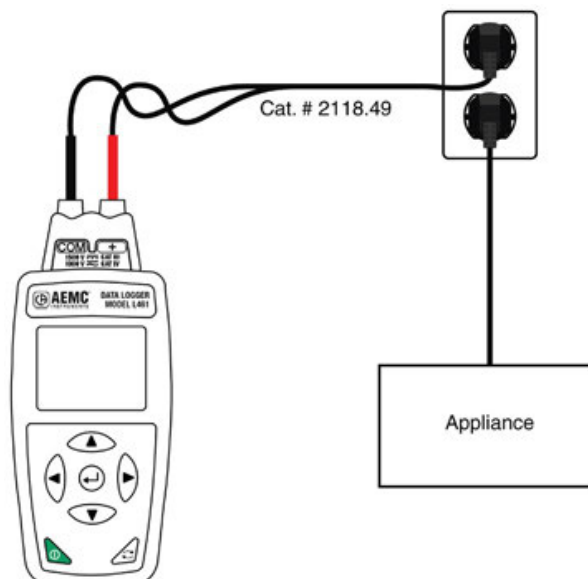

Figure 29

## 4.2 STARTING AND STOPPING A RECORDING



**NOTE:** During a recording, it is not possible to modify the configuration of the instrument.

To start a recording:

- Check that there is enough memory, or but not , (see § 6.11 Memory).
- Press the **Control** button. The instrument displays:  
**START REC. PRESS ENTER** **TO START RECORDING.** If it displays **SD CARD FULL**, the memory is full and recordings cannot be made.
- Press the **Enter** button to confirm. The **REC** icon blinks for 5 seconds, then remains lit in Normal mode or blinks every 5 seconds in Extended mode.

To stop a recording:

- Press the **Control** button. The instrument displays:  
**STOP REC. PRESS ENTER** **TO STOP RECORDING.**
- Press the **Enter** button to confirm. The **REC** icon disappears.

Recordings can also be managed from the Data Logger Control Panel (see § 5 DataView®).

## 4.3 MEASURED VALUE DISPLAY MODES

The instrument has two measurement display modes, Measurement mode and Maximum mode , represented by the icons at the top of the display. To switch from one mode to another, use the or **Navigation** buttons.

The displays can be accessed as soon as the instrument is turned on but the values are at zero. As soon as voltage or current is present at the inputs, the values are updated.

### 4.3.1 Measurement Mode

This mode is used to display the values in real time.

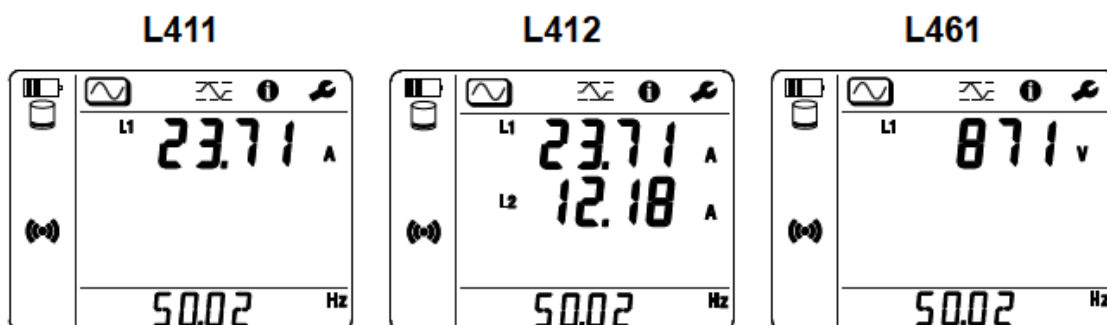

Figure 30

For Model L412, if the current sensor is not detected, the measurements are not displayed (--- is shown).

For Model L461, if it is a continuous measurement, instead of frequency, the instrument displays **DC**.

L461

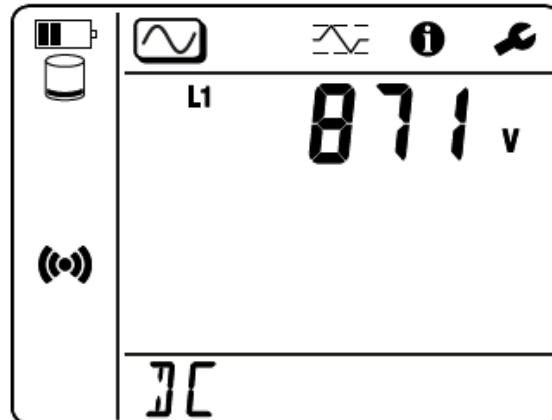

Figure 31

#### 4.3.2 Maximum Mode

This mode displays the maximum aggregated values of the measurements.

Depending on the option selected, these may be the maximum aggregated values for the recording in progress or the maximum aggregated values of the last recording, or the maximum aggregated values since the last reset to zero.

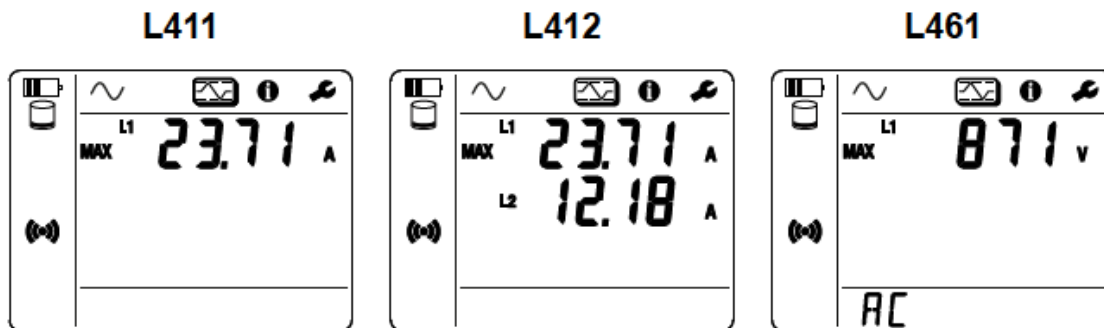

Figure 32



**NOTE:** For Model L461, the maximum DC values may be negative.

---

## 5. DATAVIEW® SOFTWARE

---

**DataView** enables a computer to connect to and interact with a variety of AEMC® Instruments devices, including Data Logger Models L411, L412 & L461. The primary purpose of DataView is to view data that has been recorded by the instrument and display it as a report. It allows you to open recordings, upload them to a PC, export them to a spreadsheet, view the corresponding curves and create and print reports. DataView® will also inform you if a firmware update is available.

With DataView application software, you can:

- Connect the instrument to the PC via USB or Wi-Fi.
- Configure the instrument: Give a name to the instrument, choose the automatic power-off time, lock the **Control**  button on the instrument, set the date and time, and format the SD card.
- Configure communication between the instrument, PC and network.
- Configure recordings: Choose their names, duration, start and end date, aggregation period and the type of recording.
- Configure the instrument: Choose AC/DC (L461), choose the frequency, configure the current sensors (L411 and L412), select whether MAX values are aggregated or not. This configuration can be password protected.

During installation you will be able to select which AEMC® Instruments Control Panels you want to install. If you intend to use DataView® for report generation, you **MUST** install the DataView Core control panel.

If not using DataView to connect to a control panel, you can perform limited configurations direct through the instrument front panel (see § 3.2.1 Configuring Instrument).

### 5.1 INSTALLING THE SOFTWARE®

---

**NOTE:**



1. You must have administrator rights on your PC to install the DataView Data Logger application software.
2. **DO NOT** connect the instrument to the computer before installing the software and drivers.

---

To install the software:

1. Insert USB Drive into an available USB port.
2. When the DataView folder opens, **double-click** on  (Setup.exe).
3. The DataView Installer (setup) screen appears.
  - a. From language section **select** desired language for UI.
  - b. From Options list **select** DataView Version.

In addition, you can also select **Adobe Reader**. This links to the Adobe web site where you can download the latest version of Reader to later view the DataView .PDF documents.

The Option **User Manuals** displays a list of .PDF files contained in the USB drive that accompanies DataView.

When ready, **click Install**. If prompted to allow changes to device, **click Yes**.

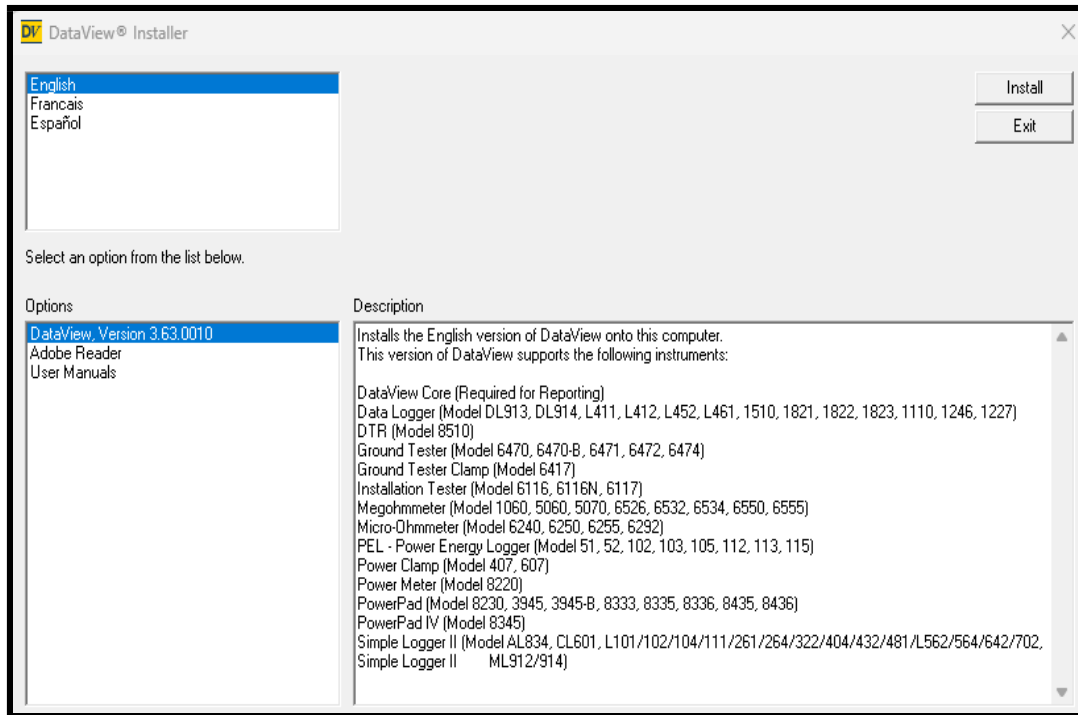
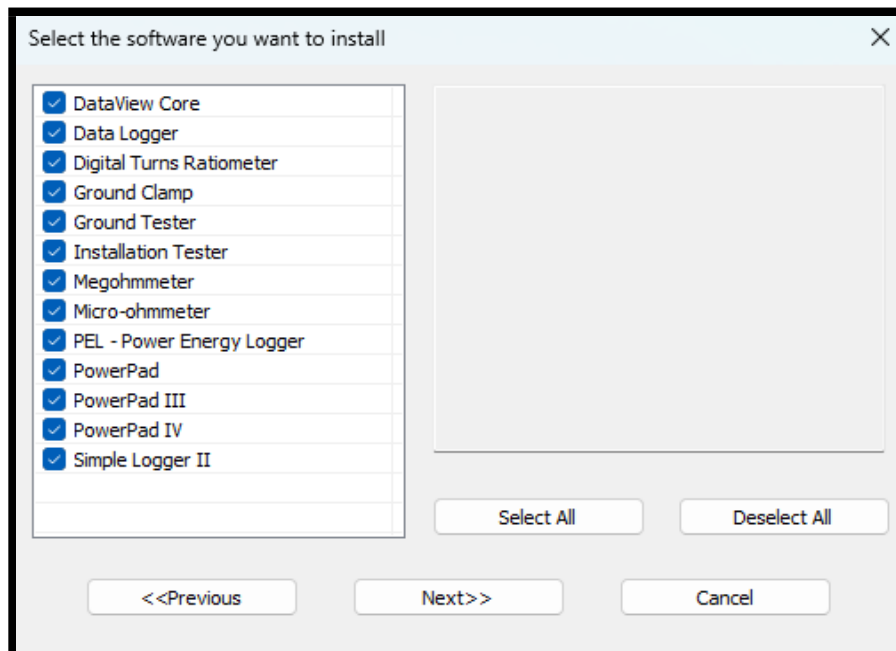

**Figure 33**

4. Each AEMC® product family has its own Control Panel. The **Select the software you want to install** screen appears with all options pre-selected indicating a complete install.

**NOTE:** To later **enable** DataView for report generation, you **MUST now select** DataView Core for install.

To save disk space, **deselect** the software that you **do not** want to install and **click Next**. At any time to review previous selections, **click Previous**.



**Figure 34**

5. The **Install confirm** screen will appear. If the USB Instrument (or cable) is connected to the computer **disconnect** it from computer before proceeding. When ready, **click Install** to proceed. The InstallShield® Wizard begins running.

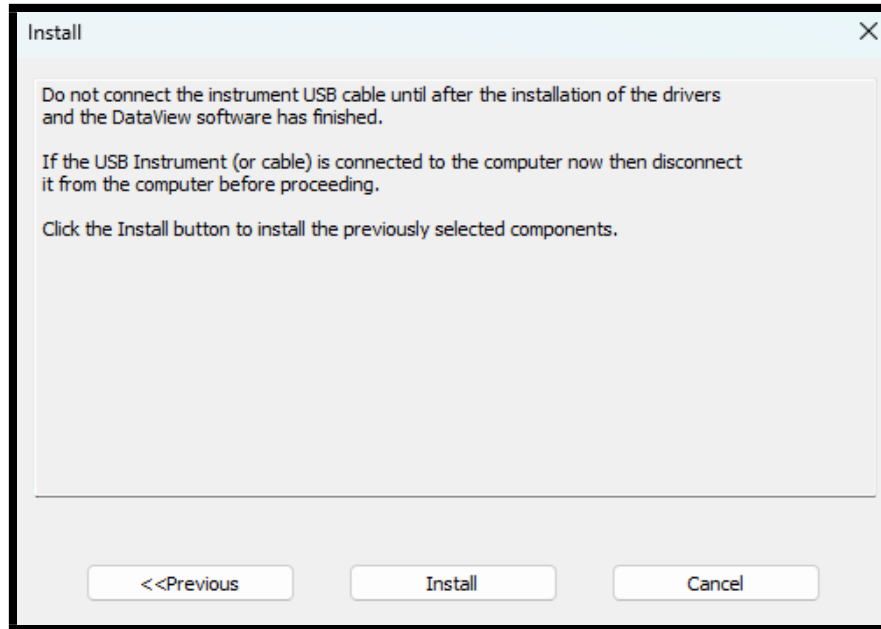

**Figure 35**

6. The InstallShield® Wizard program installs the selected software. If an earlier version of the software is already installed on your PC, for each selected program the InstallShield® Wizard will:
  - (a) Ask you to confirm the installation of the program. **Click Next.**
  - (b) Display a status bar indicating the progress of the installation.
7. When the InstallShield® Wizard has completed, the **Installation of components is complete** screen will appear. **Click Finish.**

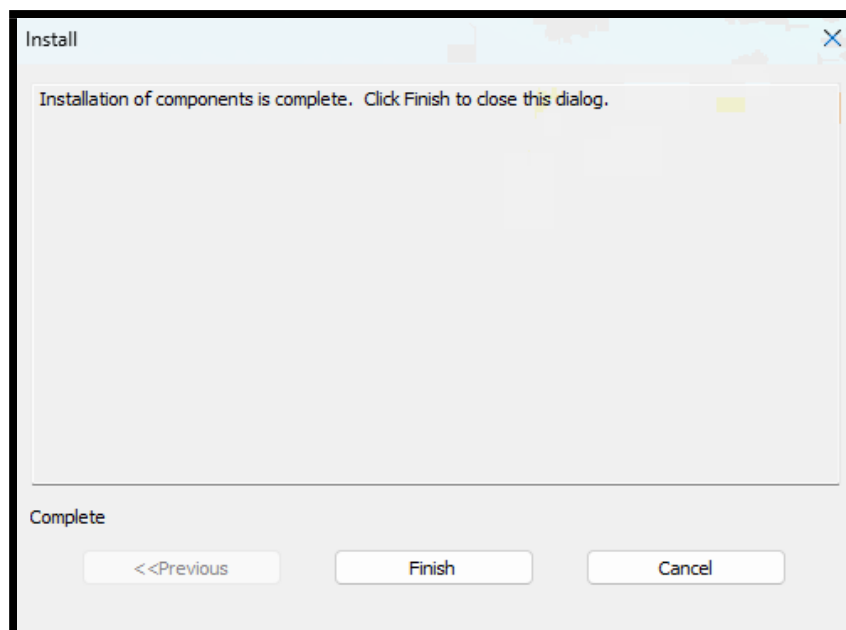

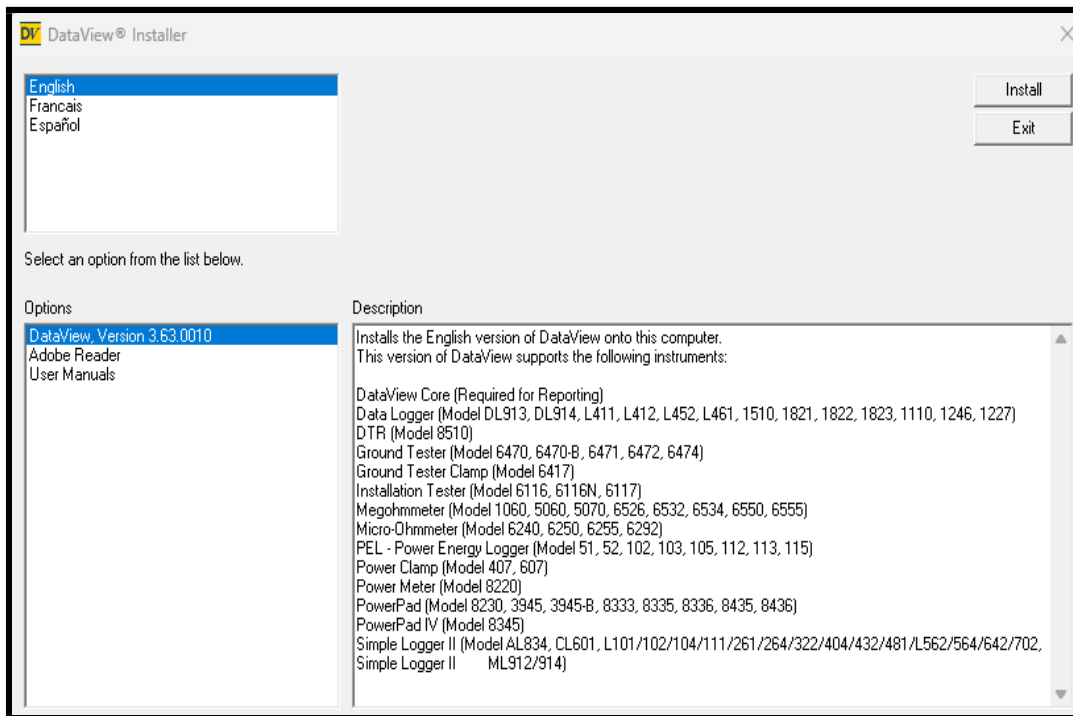

**Figure 36**

8. The program returns to the **DataView Installer** screen. **Click Exit.**



**Figure 37**

9. The DataView folder now appears on your PC desktop , within which is the Data Logger Control Panel icon  and icons for any other Control Panels installed. **Clicking the Data Logger Control Panel icon** opens the Data Logger Control Panel. **Clicking the DataView ** icon in the DataView folder opens the **DataView Core** program.
10. You can now open the Data Logger Control Panel and connect your instrument to the computer. Follow the instructions on the instrument.

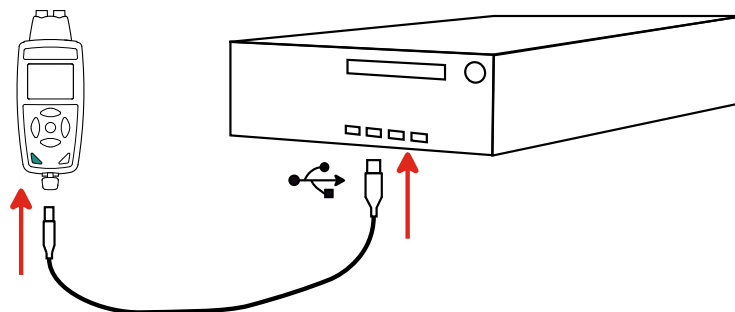

**Figure 38**

**NOTE:** For further information on using the Data Logger Control Panel, access **Help** by **pressing F1** from any screen or by **clicking** on the Help  icon located on the control panel's top menu bar.

## 6. SPECIFICATIONS

### 6.1 REFERENCE CONDITIONS

Parameter	Reference Conditions
Ambient Temperature	23 ± 2 °C
Relative Humidity	(45 to 75) % RH
Preheating	The instrument must have been powered up for at least one hour.
Common Mode	Without (the instrument is powered by batteries).
Magnetic Field	< 40 A/m AC
Electric Field	0 V/m AC
Harmonics	< 0.1 %

Table 7

### 6.2 ELECTRICAL SPECIFICATIONS

#### 6.2.1 General

Intrinsic uncertainties are expressed in % of reading (R) with an offset in number of points:  $\pm (a \% R + b)$

$$I_{nom} = I_{rated}$$

#### 6.2.2 Model L411

##### 6.2.2.1 Specific Reference Conditions

Influencing Quantity	Conditions of Reference
Current	No DC component
Frequency	50 Hz ± 0.1 Hz or 60 Hz ± 0.1 Hz
Conductor	Centered in current sensor, no external conductor

Table 8

##### 6.2.2.2 Current Measurement Specifications

Range	300 A		3000 A	
Specified Measurement Range	(0.40 - 99.99) A	(90.0 - 360.0) A	(2.0 - 99.99) A	(0.900 - 3.600) kA
Resolution	10 mA	100 mA	100 mA	1 A
Intrinsic Uncertainty	± (1 % R + 10 cts)	± (1 % R + 4 cts)	± (1 % R + 5 cts)	± (1 % R + 4 cts)

Table 9

For the 300 A range, above 400 A, the instrument displays **OL**.

For the 3000 A range, above 3800 A, the instrument displays **OL**.

### 6.2.2.3 Current Sensor Thresholds

Below the threshold, the displayed measurement is set to zero.

Rated Current	Number of Turns	Threshold
3000 A	1	1 A
	2	0.5 A
	3	0.4 A
300 A	1	0.24 A
	2	0.12 A
	3	0.08 A

Table 10



**NOTE:** See also current sensor limitation (§ 6.2.3.2. Specifications of the Current Sensors).

### 6.2.2.4 Frequency Measurement Specifications

Specified Measurement Range	(45.00 to 65.00) Hz
Resolution	0.01 Hz
Intrinsic Uncertainty	± 0.1 Hz

Table 11

Outside the measurement range, the instrument displays - - - -.

## 6.2.3 Model L412

### 6.2.3.1 Specific Reference Conditions

Influencing Quantity	Conditions of Reference
Current	No DC component
Frequency	50 Hz ± 0.1 Hz or 60 Hz ± 0.1 Hz
Conductor	Centered in current sensor, no external conductor

Table 12

### 6.2.3.2 Specifications of the Current Sensors



**NOTE:** Refer to either the Safety Data Sheet supplied with the current sensor or the current sensor's user manual.

The measurement ranges are those of the current sensors. Sometimes they may differ from the ranges measurable by the instrument.

The measurement range of the Model L412 is [0.2 %  $I_{nom}$ ; 120 %  $I_{nom}$ ]

The uncertainty of the Model L412 is ± (1 % R + 0.1 %  $I_{nom}$ )

where  $I_{nom}$ : nominal current of the selected current sensor  
R: reading the measurement

The total uncertainty is the sum of the uncertainty of the instrument and the uncertainty of the current sensor.

### SR193-BK

Specified Measurement Range	(1.00 to 49.99) A	(50.00 to 99.99) A	(90.0 to 99.99) A	(0.900 to 1.200) kA
Resolution	10 mA	10 mA	100 mA	1 A
Intrinsic Uncertainty	$\pm (1 \% R + 2 \text{ cts})$	$\pm (0.5 \% R + 1 \text{ ct})$	$\pm (1 \% R + 1 \text{ ct})$	$\pm (1 \% R + 1 \text{ ct})$

**Table 13**

Above 1200 A, the instrument displays **OL**.

### MN93-BK

Specified Measurement Range	(0.50 to 99.99) A	(90.0 to 240.0) A
Resolution	10 mA	100 mA
Intrinsic Uncertainty	$\pm (1 \% R + 10 \text{ cts})$	$\pm (1 \% R + 1 \text{ ct})$

**Table 14**

Above 240 A, the instrument displays **OL**.

### MN193-BK

Specified Measurement Range 100 A Range	(0.200 to 99.99) A	(9.00 to 99.99) A	(90.0 to 120.0) A
Resolution	1 mA	10 mA	100 mA
Intrinsic Uncertainty	$\pm (1 \% R + 2 \text{ cts})$	$\pm 1 \% R$	

**Table 15**

Above 120 A, the instrument displays **OL**.

Specified Measurement Range 5 A Range	(0.010 to 0.249) A	(0.250 to 6.000) A
Resolution	1 mA	1 mA
Intrinsic Uncertainty	$\pm (1.5 \% R + 1 \text{ ct})$	$\pm 1 \% R$

**Table 16**

Above 6 A, the instrument displays **OL**.

## Measurement Units and Range for the MN93A Clamp

MN193-BK 5 A measuring range: (5 to 25,000) A

Measurement Range	999.9	9.999	99.99	999.9	9.999	99.99
Unit	mA *	A	A	A	kA	kA

\* For Data Logger Control Panel software application only.

**Table 17**

## MN94

Specified Measurement Range	(00.10 to 99.99) A	(90.0 to 240.0) A
Resolution	10 mA	100 mA
Intrinsic Uncertainty	$\pm (0.6 \% R + 1 \text{ ct})$	$\pm (0.3 \% R + 1 \text{ ct})$

**Table 18**

Above 240 A, the instrument displays **OL**.

## MiniFlex® / AmpFlex®

Range	300 A		3000 A	
Specified Measurement Range	(0.50 to 99.99) A	(90.0 to 360.0) A	(2.0 to 99.99) A	(0.900 to 3600) kA
Resolution	10 mA	100 mA	100 mA	1 A
Intrinsic Uncertainty	$\pm (1 \% R + 20 \text{ cts})$	$\pm (1 \% R + 4 \text{ cts})$	$\pm (1 \% R + 10 \text{ cts})$	$\pm (1 \% R + 4 \text{ cts})$

**Table 19**

The uncertainty given is the sum of the uncertainty of the Model L412 and the MiniFlex® or AmpFlex® sensor.

For the 300 A range, above 400 A, the instrument displays **OL**.

For the 3000 A range, above 3800 A, the instrument displays **OL**.

### Limitation of AmpFlex® and MiniFlex® (L411 and L412)

As with all Rogowski sensors, the output voltage of AmpFlex® and MiniFlex® is proportional to the frequency.

A high current at high frequency can saturate the current input of the instruments.

To avoid saturation, it is necessary to satisfy the following condition:

$$\sum_{n=1}^{n=\infty} [n \cdot I_n] < I_{nom}$$

Where  $I_{nom}$  is the range of the current sensor

$n$  is the order of the harmonic

$I_n$  is the current value for the harmonic of rank  $n$

For example, the input current range of a dimmer must be one fifth of the current range selected on the instrument.

This requirement does not take into account the limitation of the instrument's bandwidth, which may lead to other errors.

### 6.2.3.3 Current Sensor Thresholds

Below the threshold, the displayed measurement is set to zero.

Sensor	Rated Current	Number of Turns	Display Threshold
SR193-BK	1000 A	-	0.50 A
MN93-BK	200 A	-	0.10 A
MN193-BK	5 A	-	2.5 mA *
	100 A	-	50 mA
MN94	200 A	-	50 mA
AmpFlex® 193-24-BK MiniFlex® A194-24-BK	300 A	1 turn	0.24 A
		2 turns	0.12 A
		3 turns	0.08 A
	3000 A	1 turn	1 A
		2 turns	0.5 A
		3 turns	0.4 A

\* This value is to be multiplied by the ratio (between 5 A and 25,000 A).

**Table 20**

### 6.2.3.4 Frequency Measurement Specifications on Channel 1

<b>Specified Measurement Range</b>	<b>(45.00 - 65.00) Hz</b>
<b>Resolution</b>	0.01 Hz
<b>Intrinsic Uncertainty</b>	± 0.1 Hz

**Table 21**

Outside the measuring range, the instrument displays - - - -.

### 6.2.4 Model L461

#### 6.2.4.1 Specific Reference Conditions

Input impedance: 7 MΩ per input

Maximum continuous overload: 1800 V<sub>AC</sub> or DC

#### 6.2.4.2 DC Measurement Specifications

AC component < 1 % DC component

<b>Specified Measurement Range</b>	<b>± 10.0 - 999.9 V</b>	<b>± 900 - 1700 V</b>
<b>Resolution</b>	100 mV	1 V
<b>Intrinsic Uncertainty</b>	± (1 % R + 5 cts)	± (1 % R + 1 ct)

**Table 22**

Above 1800 V<sub>DC</sub>, the instrument displays **OL**.

#### 6.2.4.3 AC Measurement Specifications

Frequency: 50 ± 0.1 Hz or 60 ± 0.1 Hz

Crest factor:  $\sqrt{2}$

DC component < 1 % AC component

Sinusoidal signal

<b>Specified Measurement Range</b>	<b>(10.0 - 999.9) V</b>	<b>(900 - 1200) V</b>
<b>Resolution</b>	100 mV	1 V
<b>Intrinsic Uncertainty</b>	±(1 % R + 5 cts)	±(1 % R + 1 ct)

**Table 23**

Above 1300 V<sub>AC</sub>, the instrument displays **OL**.

Voltages < 0.2 V<sub>AC</sub> are set to zero.

### 6.2.4.4 Frequency Measurement Specifications

Specified Measurement Range	(45.00 - 65.00) Hz
Resolution	0.01 Hz
Intrinsic Uncertainty	± 0.1 Hz

Table 24

Outside the measuring range, the instrument displays - - - -.

## 6.3 VARIATION IN OPERATING RANGE

### 6.3.1 Model L411

Influence Quantities	Area of Influence	Quantity Influenced	Influences
Temperature	(-20 to +50) °C	Current	± 400 ppm/°C
		Time	0.034 ± 0.006 ppm/°C
Relative Humidity	(30 to 85) % RH	Current	± (1 % R + 2 cts)
Power Supply on Batteries	(3.6 to 4.8) V	Current	± (1 % R + 1 ct)
Power Supply Over USB	(4.4 to 5.25) V	Current	± (1 % R + 1 ct)
Common Mode Rejection AC 50/60 Hz	(0 to 1000) V	Current	2 mA/V
Non-sinusoidal Signal With Harmonics < 6 kHz	Phase chopping variable speed drive	Current	1 %
	Square		1 %
	Diode bridge		Not supported
Crest Factor	1.4 to 2	Current	1 %
	2 to 3		1 % of full scale
Frequency	(45 to 65) Hz	Current	± 0.05 %/Hz
Adjacent External Conductor Carrying an AC Current at 50/60 Hz	conductor in contact with the sensor	Current	> 40 dB typical
	conductor near snap mechanism		> 33 dB
Position of Conductor in the Sensor		Current	≤ 2.5 %
Electric Field	10 V/m 100 MHz to 1 GHz	Current	< 2 % of full scale

Table 25

## 6.3.2 Model L412

Influence Quantities	Area of Influence	Quantity Influenced	Influences
Temperature	(-20 to +50) °C	Current	± 400 ppm/°C
		Time	0.034 ± 0.006 ppm/°C
Relative Humidity	(30 to 85) % RH	Current	± (1 % R + 2 cts)
Power Supply on Batteries	(3.6 to 4.8) V	Current	± (1 % R + 1 ct)
Power Supply Over USB	(4.4 to 5.25) V	Current	± (1 % R + 1 ct)
Non-sinusoidal Signal with Harmonics < 6 kHz	Phase chopping variable speed drive	Current	1 %
	Square		1 %
	Diode bridge		Not supported
Crest Factor	1.4 to 2	Current	1 %
	2 to 3		1 % of full scale
Frequency	(45 to 65) Hz	Current	± 0.05 %/Hz
External Conductor		Current	see the specifications of the current sensor (§ 6.2.3.2)
Position of Conductor		Current	
Magnetic Field		Current	
Electric Field	10 V/m 100 MHz to 1 GHz	Current	

Table 26

### 6.3.2.1 Disturbed Signals

The bandwidth of the following signals must be < 6 kHz. The current is between 5 % and 50 % of the rated value.

Signal Type	Sensor	Typical Influence
Phase Chopping Variable Speed Drive	MN193-BK	< 1 %
	MA194-24-BK	< 3 %
Square	MN193-BK	< 1 %
	MA194-24-BK	< 3 %

Table 27

Signals from a bridge rectifier with a DC component are not supported by Model L411 and Model L412.

### 6.3.3 Model L461

Influence Quantities		Area of Influence	Quantity Influenced	Influences
Temperature		(-20 to +50) °C	VDC	± 52 mV/°C
			VAC	± 110 ppm/°C
			Time	0.034 ± 0.006 ppm/°C
Relative Humidity		(30 to 85) % RH	V	± (1 % R + 2 cts)
Power Supply on Batteries		(3.6 to 4.8) V	V	± (1 % R + 1 ct)
Power supply over USB		(4.4 to 5.25) V	V	± (1 % R + 1 ct)
Common Mode Rejection	AC	(0 to 1000) VAC	VDC	65 dB
	DC	(-1000 to 1000) VDC	VAC	65 dB
Serial Mode Rejection	AC	(0 to 800) VAC	VDC	47 dB
	DC	(-500 to 500) VDC	VAC	47 dB
Frequency		(45 to 65) Hz	VAC	± 0.05 %/Hz

Table 28

## 6.4 POWER SUPPLY

### 6.4.1 Batteries

The instrument is powered by 3 alkaline batteries type AA or LR6.

**Battery weight:** Approx. 3 x .92 oz (3 x 26 g)

**Consumption:** 120 mA max

**Battery life with new batteries:**

- 3 days recording without Wi-Fi
- 1 day with Wi-Fi enabled
- When recording in **EXTENDED** mode without Wi-Fi:
  - 2 weeks for a 1 minute aggregation period
  - 10 weeks for a 10/15 minutes aggregation period

When power is off, the real time clock is retained for more than 120 days.

When the batteries are exhausted, the configuration is retained for 5 years.

The instrument can also be powered by rechargeable batteries, but the battery life will be shorter. Use NiMH type AA or LR6, 2500 mA·h.

## 6.4.2 Via USB

The instrument can also be powered via a micro USB cable, plugged either into a PC or into a wall socket via an AC adapter.

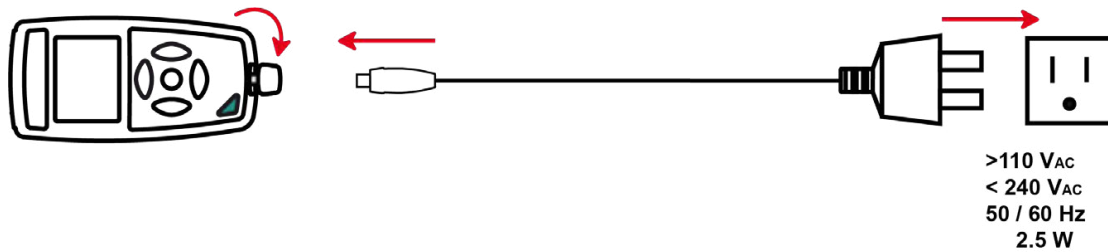

Figure 39

**Operating range:** (4.4 to 5.25) V

**Power:** 0.6 W max

## 6.5 ENVIRONMENTAL SPECIFICATIONS

**Temperature and Relative Humidity:**

1 =	<b>Reference Range:</b>	(68 to 78.8) °F (20 to 26) °C from (45 to 75) % RH
1+2 =	<b>Operating Range:</b>	(14 to 107.6) °F (-10 to 42) °C from (10 to 85) % RH (14 to 122) °F (-10 to 50) °C from (10 to 75) % RH
1+2+3 =	<b>Storage Range (w/ batteries):</b>	(-40 to 95) °F (-40 to 35) °C from (0 to 95) % RH (-40 to 158) °F (-40 to 70) °C from (0 to 75) % RH

% RH

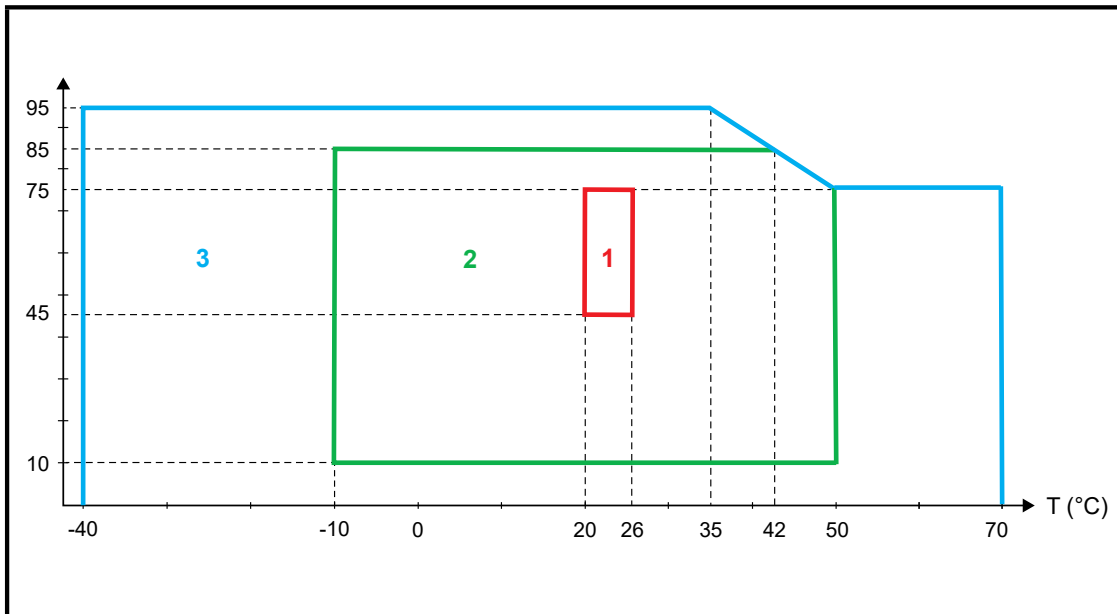

Figure 40

For indoor use.

Altitude:

- Operation: (0 to 2000) m
- Storage: (0 to 10,000) m

## 6.6 WI-FI

2.4 GHz IEEE 802.11 B/G/N band

Tx power: +15.1 dBm

Rx sensitivity: -96.3 dBm

Security: open / WPA2

## 6.7 MECHANICAL SPECIFICATIONS

### 6.7.1 Model L411

- **Dimensions:** (5.79 x 2.83 x 1.34) in approx. (147 × 72 × 34) mm approx.
- **Cable:** 3.94 ft (1.20 m)
- **Current Sensor:** 13.78 in (350 mm)
- **Weight:** Approximately 10.58 oz (340 g)
- **Degree of protection** provided by the enclosure according to IEC 60529
  - IP 54 for the instrument
  - IP 67 for the current sensor

### 6.7.2 Model L412

- **Dimensions:** (6.77 x 2.83 x 1.34) in approx. (172 × 72 × 34) mm approx.
- **Weight:** Approximately 10.58 oz (300 g)
- **Degree of protection** provided by the enclosure according to IEC 60529:
  - IP 54 when the instrument is not in use
  - IP 20 when the instrument is connected

### 6.7.3 Model L461

- **Dimensions:** (7.01 × 2.83 x 1.34) in approx. (178 × 72 × 34) mm approx.
- **Weight:** Approximately 10.58 oz (300 g)
- **Degree of protection** provided by the enclosure according to IEC 60529:
  - IP 54 when the instrument is not in use
  - IP 20 when the instrument is connected

## 6.8 COMPLIANCE WITH INTERNATIONAL STANDARDS

The instruments comply with the EN 62479 standards for EMF.

### 6.8.1 Model L411

The instrument complies with standard IEC/EN 61010-2-0322 for a voltage of 600 V in CAT IV or 1000 V in CAT III, pollution degree 2.

### 6.8.2 Model L412

The instrument complies with standard IEC/EN 61010-2-030 for a voltage of 600 V in CAT IV or 1000 V in CAT III, degree of pollution 2.

### 6.8.3 Model L461

The instrument complies with standard IEC/EN 61010-2-030 for a voltage of 1000 V<sub>AC</sub> in CAT IV or 1500 V<sub>DC</sub> in CAT III pollution degree 2.

The leads and alligator clips comply with IEC/EN 61010-031 for a voltage of 1000 V in CAT IV or 1500 V in CAT III pollution degree 2.

## 6.9 ELECTROMAGNETIC COMPATIBILITY

Emissions and immunity in an industrial environment compatible with IEC/EN 61326-1 or BS EN 61326-1.

With the AmpFlex® and MiniFlex®, the typical influence on the measurement is 0.5 % of full scale with a maximum of 5 A.

## 6.10 RADIO EMISSIONS





The instruments are in compliance with directive RED 2014/53/EU and with FCC regulations.

FCC certification number for the Wi-Fi: QQQWFM200.

## 6.11 MEMORY

The instrument contains a micro-SD card with a capacity of 8 GB formatted FAT32. This card allows recording for 100 years, but the number of recording sessions is limited.

The memory icon on the display indicates that it is full:

-  : number of sessions ≤ 50
-  : number of sessions > 50
-  : number of sessions > 100
-  : number of sessions > 150
-  : number of sessions > 200

Recording sessions can be downloaded and/or deleted individually via the Data Logger Control Panel application software.

---

## 7. MAINTENANCE

---



**WARNING:** The device does not contain any parts that can be replaced by untrained or unaccredited personnel. Any unauthorized work or part replacement with equivalents may seriously compromise safety.

---

### 7.1 CLEANING

---





**WARNING:** Disconnect the instrument from any source of electricity.

---

The instrument should be cleaned periodically to keep the LCD clear and prevent the buildup of dirt and grease around the instrument's buttons.

- Turn the instrument OFF.
- Clean the body of the instrument with a damp and soapy cloth.
- Do not submerge the instrument in water.
- Do not use alcohol, solvents, or hydrocarbons.
- Ensure that no foreign bodies interfere with the current sensor snap-on system.

### 7.2 REPLACING THE BATTERY

The  icon indicates the remaining battery capacity. When the  icon is empty, all the batteries must be replaced.

- Disconnect all connections to the instrument's measurement inputs and switch it off.
- To avoid losing the time, power the device via USB while replacing the batteries.
- Refer to § 1.7 Installing the Batteries, to proceed with the replacement.



**NOTE:** Do not treat spent batteries as ordinary household waste. Take them to the appropriate collection facility for recycling.

---

### 7.3 UPDATING THE FIRMWARE

The Data Logger Models L411, L412 or L461 firmware controls the features and functionality of the instrument. AEMC® Instruments provides firmware updates free of charge to download through our DataView® Data Logger Control Panel software.

Once a connection has been established with the instrument, the instrument will alert the user if a firmware update is available on the AEMC® Instruments website. To proceed with the firmware update, the user should then follow the step-by-step instructions provided on the instrument's display.



**WARNING:** Updating the firmware could reset the configuration and cause loss of stored data. As a precaution, save the stored data to a PC before updating the firmware.

---

## 7.4 REPLACING THE SD CARD

If you press the **Control**  button to start a recording and the instrument displays any of the messages below, the SD card has a problem.

- **INSERT SD CARD**
- **SD CARD WRITE PROTECT**
- **SD CARD ERROR**

If this occurs, connect your instrument to the Data Logger Control Panel application software. In the configuration function, you can then format the SD card.

If this does not solve the problem, you will need to replace the SD card.

### 7.4.1 Instructions to Replace SD Card

1. Disconnect all connections to the instrument and turn it OFF.
2. Turn the instrument over and unscrew the (4) screws using a Phillips screwdriver (Figure 41).



**NOTE:** Before opening the instrument, be sure to take all necessary precautions against electrostatic discharge (ESD).

3. Remove the bottom from the instrument and lay it aside (see Figure 42).

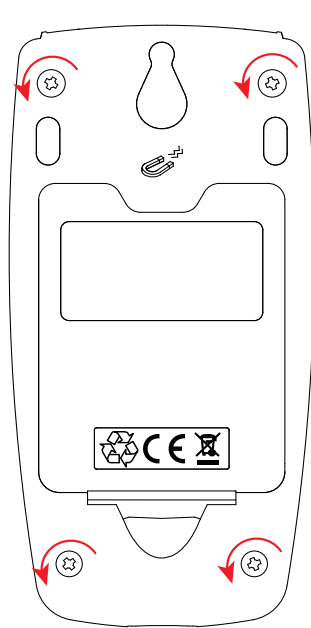

**Figure 41**

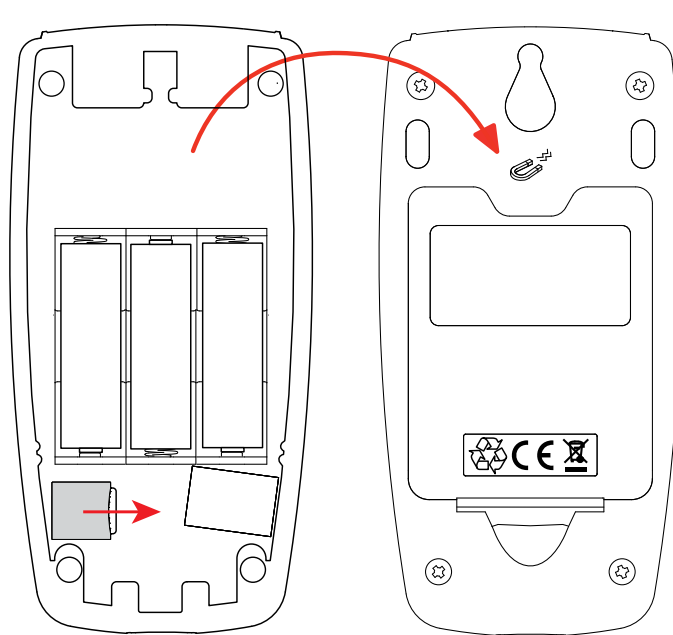

**Figure 42**

4. Push the SD card slot to the right to unlock it (see Figure 42).
5. Next, open and lift SD card up and remove it by sliding it upwards.
6. Insert the new SD card, formatted to FAT 32, into the slot by sliding it into the guides. Following the guides will ensure that the card is inserted in the correct orientation. Push the SD card in all the way.

7. Push the SD card slot down and push it to the left to lock it (see Figure 43).

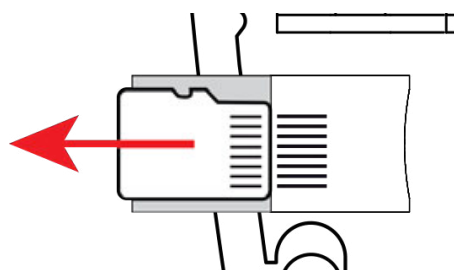

**Figure 43**

8. Replace the bottom of the instrument, making sure that it is completely and correctly closed. Next, screw the (4) screws back in place.

## 7.5 MESSAGES

### 7.5.1 Main Messages Concerning Wi-Fi

AP CONFIG TCPIP FAILED	AP Mode: TCP/IP configuration failed
AP DHCP SERVER FAILED	AP Mode: Failed to start DHCP server
AP MODE START FAILED	AP Mode: Failed to start AP mode
AP POWER MODE FAILED	AP mode: Max power saving mode configuration failed
AP SCAN FAILED	AP Mode: Network scan failed
AP SET PASSWORD FAILED	AP Mode: Failed to set AP mode password
AP UDP SERVER FAILED	AP Mode: Failed to start UDP server
AP TCP SERVER FAILED	AP Mode: Failed to start TCP server
CONFIG AP	Configures the module for operation as an access point
CONFIG DHCP	Configures the modules for the DHCP server
CONFIG HTTP SERVER	Configures the modules for the HTTP server
CONFIG ST	Configures the module for ST mode (router)
CONFIG TCP	Configures TCP settings
CONFIG TCP SERVER	Configures the TCP server settings
CONFIG TCPIP	Configures the TCP/IP settings
CONFIG UDP/TCP SERVER	Configures the modules for UDP/TCP server
CONFIG UDP SERVER	Configures the UDP server settings
CONNECT SSID	Connection to an SSID server
DISABLED	Disabled by user
FLASHING Wi-Fi MODULE	Programming the Wi-Fi module
HTTP SERVER FAILED	Failed to start HTTP server
INIT FAILURE	Initialization failed
NO CONFIG TCPIP RSP	STA mode: No TCP/IP response configuration
NO CONFIG TCPIP EVT	STA mode: No TCP/IP event configuration
NO GET MAC EVT	No response from MAC event
NO GET MAC EVT	No response from MAC address
NO HELLO RSP	No Hello response
NO OP MODE RSP	No response to set operating mode (STA or AP)
NO POWER MODE RSP	STA mode: No response to set Max power saving mode
NO RADIO ON EVT	STA mode: No response to Radio On event
NO RADIO ON RSP	STA mode: No radio activation response

NO RESPONSE	Module did not respond to hard reset
NO SET MAC RSP	No response to setting MAC address
NO SET PASSWORD RSP	STA mode: No response to setting Wi-Fi password
NO SYNC RSP	No sync response
POWER ON	Powering up the module
POWER MODE AP	Set power mode for Wi-Fi AP operation
POWER MODE ST	Set power mode for ST Wi-Fi operation
RADIO ON	Activation of the radio in the module
RADIO ON AP	Activate radio
RADIO ON FAILED	AP Mode: Radio Power On failed
RESETTING MODULE	Resetting the module
SET 80211 MODE	Set 802.11 operating mode
SET 80211 MODE FAILED	Failed to set 802.11 operating mode
SET AP MODE FAILED	AP Mode: Failed to set AP mode
SET AP PASSWORD	Set AP mode password
SET PASSWORD	Set password to use when connecting to an existing SSID
SETTING BPS RATE	Set the BPS of the module
SETTING OPERATING MODE	Setting the module operating mode
SSID SCAN AP	Scan SSID
SSID ERROR	Failed to connect to specified SSID
START AP SERVER	Start the server in AP mode
START TCP AP SERVER	Start the TCP server for operation in AP mode
START TCP SERVER FAILED	STA Mode: Failed to start TCP server
START UDP AP SERVER	Start the UDP server for operation in AP mode
START UDP SERVER FAILED	STA Mode: Failed to start UDP server
START UDP/TCP AP SERVER	Start UDP/TCP servers in APs mode
VALIDATE FAILED	Validation failed
VALIDATING MAC	Checking the validity of the MAC address
WAITING FOR BOOT EVENT	Waiting for the module to send a boot event message
WAIT FOR HELLO MSG	Waiting for module greeting
WAITING FOR SYNC	Waiting for module synchronization messages

## 7.6 REPAIR AND CALIBRATION

To ensure that your instrument meets factory specifications, we recommend that it be sent back to our factory Service Center at one-year intervals for recalibration or as required by other standards or internal procedures.

### For instrument repair and calibration:

You must contact our Service Center for a Customer Service Authorization Number (CSA#). Send an email requesting a CSA#, you will be provided a CSA Form and other required paperwork along with the next steps to complete the request. Then return the instrument along with the signed CSA Form. This will ensure that when your instrument arrives, it will be tracked and processed promptly. Please write the CSA# on the outside of the shipping container. If the instrument is returned for calibration, we need to know if you want a standard calibration or a calibration traceable to N.I.S.T. (includes calibration certificate plus recorded calibration data).

**Ship To:** Chauvin Arnoux®, Inc. d.b.a. AEMC® Instruments

**(Or contact your authorized distributor.)**

Contact us for the costs for repair, standard calibration, and calibration traceable to N.I.S.T.



**NOTE:** You must obtain a CSA# before returning any instrument.

---

## 7.7 TECHNICAL SUPPORT

If you are experiencing any technical problems or require any assistance with the proper operation or application of your instrument, please call or e-mail our technical support team:

Chauvin Arnoux®, Inc. d.b.a. AEMC® Instruments

## 7.8 LIMITED WARRANTY

The instrument is warranted to the owner for a period of two years from the date of original purchase against defects in manufacture. This limited warranty is given by AEMC® Instruments, not by the distributor from whom it was purchased. This warranty is void if the unit has been tampered with, abused, or if the defect is related to service not performed by AEMC® Instruments.

**Full warranty coverage and product registration is available on our website.**

**Please print the online Warranty Coverage Information for your records.**

### **What AEMC® Instruments will do:**

If a malfunction occurs within the warranty period, you may return the instrument to us for repair, provided we have your warranty registration information on file or a proof of purchase. AEMC® Instruments will repair or replace the faulty material at our discretion.

### **7.8.1 Warranty Repairs**

#### **What you must do to return an Instrument for Warranty Repair:**

First, send an email requesting a Customer Service Authorization Number (CSA#) from our Service Department. You will be provided a CSA Form and other required paperwork along with the next steps to complete the request. Then return the instrument along with the signed CSA Form. Please write the CSA# on the outside of the shipping container. Return the instrument, postage or shipment prepaid to:

Chauvin Arnoux®, Inc. d.b.a. AEMC® Instruments

**Caution: To protect yourself against in-transit loss, we recommend that you insure your returned material.**



**NOTE:** You must obtain a CSA# before returning any instrument.

---

---

## 8. APPENDIX

---

### 8.1 MEASUREMENT FORMULAS

#### 8.1.1 Aggregation

Aggregated quantities are calculated by the Data Logger Control Panel software application for a defined period according to the following formulas based on **1 s** values.

The aggregation can be an average or a quadratic average.

Quantities	Formulas
AC RMS Voltage	$V_L = \sqrt{\frac{1}{N} \times \sum_{x=0}^{N-1} V_{Lx}^2}$
DC Voltage	$V_L = \frac{1}{N} \times \sum_{x=0}^{N-1} V_{Lx}$
AC RMS Current	$I_L = \sqrt{\frac{1}{N} \times \sum_{x=0}^{N-1} I_{Lx}^2}$

Table 29

N = number of 1 s values during the aggregation period concerned (1, 2, 3, 4, 5, 6, 10, 12, 15, 20, 30 or 60) minutes.

#### 8.1.2 Normal Mode

In Normal mode, there was a **1 s** measurement every second and the aggregation covers 60 measurements, giving an accurate result.

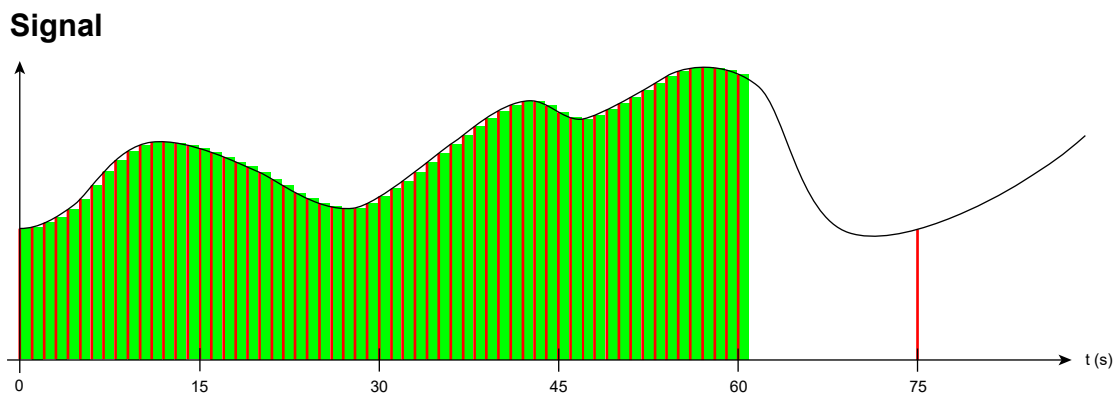

Figure 44

### 8.1.3 Extended Mode

In Extended mode, the interval between measurements,  $s$ , is a quarter of the aggregation period.

For example, for an aggregation period of one minute, the  $1\ s$  measurement will be made every 15 seconds. The four (4)  $1\ s$  measurements will then be aggregated.

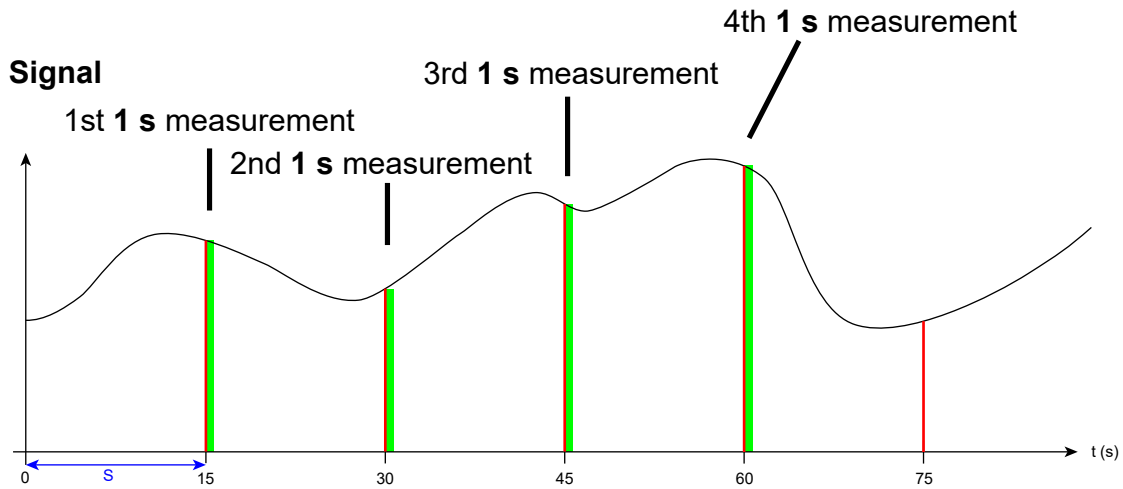

Figure 45

**NOTES:**

---

**NOTES:**

---

**NOTES:**

---



05/26  
99-MAN 100644 v00

---

**AEMC<sup>®</sup> Instruments**