

Data Logger Models L411, L412 & L461



DATA LOGGERS

REGISTER ONLINE NOW!

Activate Your New Product Warranty
and Qualify for Exciting Giveaways!

Measure Up
WITH AEMC INSTRUMENTS[®]



Copyright© Chauvin Arnoux®, Inc. d.b.a. AEMC® Instruments. All rights reserved.

No part of this documentation may be reproduced in any form or by any means (including electronic storage and retrieval or translation into any other language) without prior agreement and written consent from Chauvin Arnoux®, Inc., as governed by United States and International copyright laws.

Chauvin Arnoux®, Inc. d.b.a. AEMC® Instruments

This documentation is provided **as is**, without warranty of any kind, express, implied, or otherwise. Chauvin Arnoux®, Inc. has made every reasonable effort to ensure that this documentation is accurate; but does not warrant the accuracy or completeness of the text, graphics, or other information contained in this documentation. Chauvin Arnoux®, Inc. shall not be liable for any damages, special, indirect, incidental, or inconsequential; including (but not limited to) physical, emotional or monetary damages due to lost revenues or lost profits that may result from the use of this documentation, whether or not the user of the documentation has been advised of the possibility of such damages.

Statement of Compliance

Chauvin Arnoux®, Inc. d.b.a. AEMC® Instruments certifies that this instrument has been calibrated using standards and instruments traceable to international standards.

We guarantee that at the time of shipping your instrument has met the instrument's published specifications.

An NIST traceable certificate may be requested at the time of purchase, or obtained by returning the instrument to our repair and calibration facility, for a nominal charge.

The recommended calibration interval for this instrument is 12 months and begins on the date of receipt by the customer. For recalibration, please use our calibration services. Refer to our repair and calibration section.

Serial #: _____

Catalog #: 2153.52 / 2153.53 / 2153.54

Model #: L411 / L412 / L461

Please fill in the appropriate date as indicated:

Date Received: _____

Date Calibration Due: _____



Chauvin Arnoux®, Inc.
d.b.a AEMC® Instruments

PRODUCT PACKAGING
(2153.52, 2153.53, 2153.54)



Data Logger
 Model L411
Cat. #2153.52



Data Logger
 Model L412
Cat. #2153.53



Data Logger
 Model L461
Cat. #2153.54



*Adapter - US wall plug
 to USB
Cat. #2153.78



Cable - 6 ft USB Type
 A-Type B Micro
Cat. #2138.66



Set of 2,
 10 ft (3 m) color-coded
 ST/ST leads (red/black)
Cat. #5100.29
(Included with L461 Only)



Set of 2, color-coded
 safety alligator clips
 (red/black)
Cat. #5000.99 (black)
Cat. #5100.00 (red)
(Included with L461 Only)

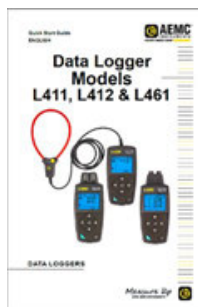

Quick Start Guide

(1) 4 GB USB Drive
 with User Manual &
 Dataview® Software

Also Included:

- (3) AA LR6 Alkaline Batteries
- (1) Declaration of Conformity
- (1) Test Report

**Replacement 5 V, 2 A USB chargers can be purchased from third-party manufacturers.*

Thank you for purchasing an AEMC® Instruments Data Logger Model L411, L412 or L461. The user manual is included on the provided USB Drive along with the DataView® software. Search on the instrument name. Under **Search Results**, click on the **instrument**. On instrument's web page, scroll down, click on **User Manuals**, and download manual.

For best results from your instrument and for your safety, read the enclosed operating instructions carefully and comply with the precautions for use. Only qualified and trained operators should use this product.

PRECAUTIONS FOR USE

These instruments comply with the following safety standards:

- **Model L411:** IEC/EN 61010-2-032 for voltages up to 600 V in CAT IV or 1000 V in CAT III.
- **Model L412:** IEC/EN 61010-2-30 and current sensors comply with IEC/EN 61010-2-032.
- **Model L461:** IEC/EN 61010-2-30 for voltages up to 1000 Vac in CAT IV or 1500 Vdc in CAT III and the leads comply with IEC/EN 61010-031.



Failure to observe the precautions for use may lead to a risk of electric shock, fire, explosion, and/or destruction of the instrument and of the installations.

- The operator and/or the responsible authority must carefully read and clearly understand the various precautions to be taken in use. Sound knowledge and a keen awareness of electrical hazards are essential when using this instrument.
- **Model L461:** Use only the supplied or specified accessories (voltage leads).
 - When assembling an instrument with leads, alligator clips or power adapter, the nominal voltage for a single measurement category is the lowest of the nominal voltages assigned to the individual components.
 - When connecting a current sensor to a measuring instrument, account must be taken of any potential feedback of voltage from the measuring instrument to the current sensor and therefore of the common mode voltage and acceptable measurement category at the current sensor secondary.
 - When handling leads and alligator clips, do not place fingers beyond the physical guard.
- Before each use, check the condition of the insulation on the leads, housing, and accessories. Any item of which the insulation is deteriorated (even partially) must be set aside for repair or scrapping.
- Do not use the instrument on networks whose voltage or category exceeds those mentioned.
- Do not use the instrument if it seems to be damaged, incomplete, or poorly closed.
- Use personal protection equipment systematically.
- If the instrument gets wet, dry it before connecting it.
- All troubleshooting and metro-logical checks must be performed by competent, accredited personnel.

INSTALLING THE BATTERIES



TURNING THE INSTRUMENT ON AND OFF





To turn the instrument on, press and hold the **ON/OFF**  button. To turn the instrument off, press and hold the **ON/OFF**  button again. The instrument cannot be turned off while a recording is in progress or pending, or when the device is connected to an external power supply.

If there is no action by the user, the instrument switches to standby mode after three minutes, this duration can be programmed at 3, 10 or 15 minutes via the Data Logger Control Panel. It continues to make measurements but they are no longer displayed.

It is also possible to switch the instrument to permanent mode, with the Data Logger Control Panel. The icon  is displayed and the instrument no longer turns off.

The blue display backlight turns on at startup. It turns off after one minute. It turns on again when a button is pressed or when the USB is connected.

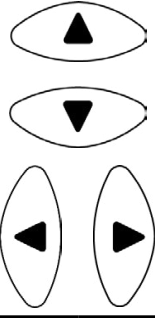
FUNCTION BUTTONS

Button	Description
	<p>On/Off Button</p> <p>A long press turns the instrument on or off.</p> <p>The instrument cannot be turned off while a recording is in progress or pending, or when the device is connected to an external power supply.</p>
	<p>Control Button</p> <p>This starts or stops a recording or allows the Wi-Fi mode to be chosen.</p>
	<p>Navigation Buttons</p> <p>Up, Down, Left & Right</p> <p>Used to configure the instrument and browse the data displayed.</p>
	<p>Enter Button</p> <p>In Configuration mode, selects a setting to change.</p> <p>In Select mode, starts or stops a recording.</p> <p>Allows the type of Wi-Fi to be chosen.</p>

LCD DISPLAY

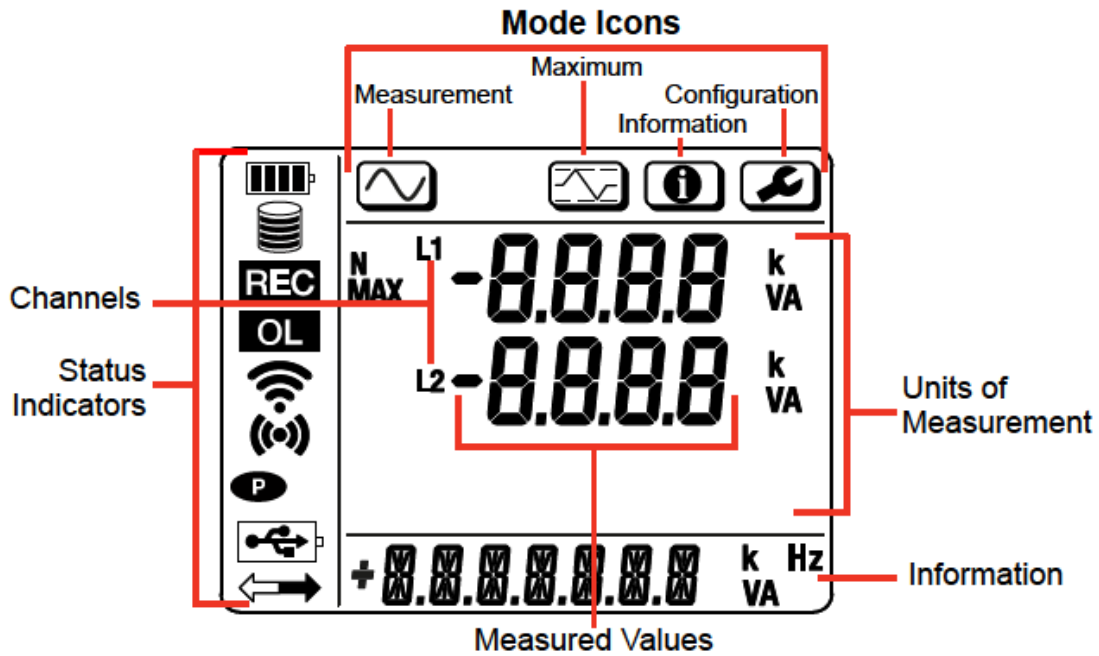

PRODUCT FEATURES

MODEL L411

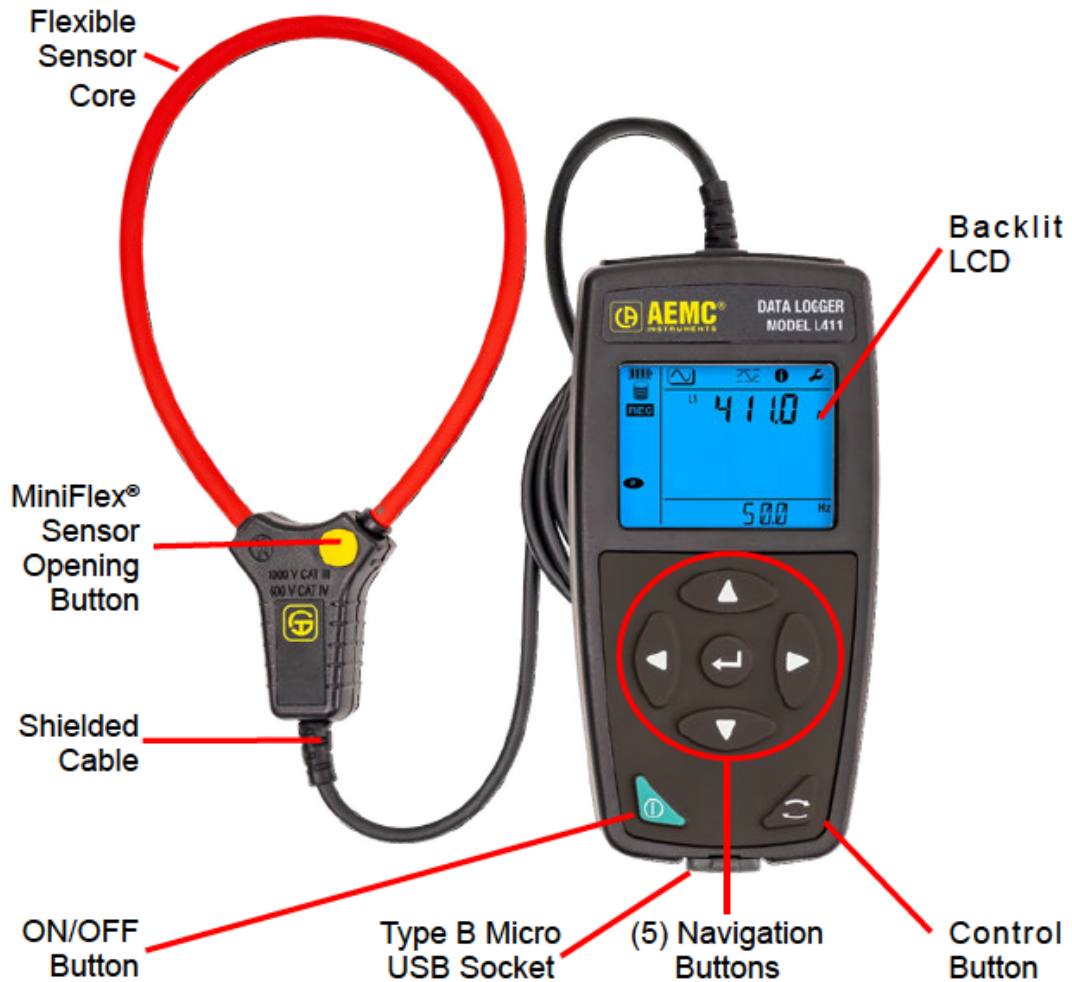

MODEL L412



MODEL L461



INSTALLING THE SOFTWARE

DataView enables a computer to connect to and interact with a variety of AEMC® Instruments devices, including Data Logger Models L411, L412 & L461. The primary purpose of DataView is to view data that has been recorded by the instrument and display it as a report. It allows you to open recordings, upload them to a PC, export them to a spreadsheet, view the corresponding curves and create and print reports. DataView® will also inform you if a firmware update is available.

With DataView application software, you can:

- Connect the instrument to the PC via USB or Wi-Fi.
- Configure the instrument: Give a name to the instrument, choose the automatic power-off time, lock the **Control**  button on the instrument, set the date and time, and format the SD card.
- Configure communication between the instrument, PC and network.
- Configure recordings: Choose their names, duration, start and end date, aggregation period and the type of recording.
- Configure the instrument: Choose AC/DC (L461), choose the frequency, configure the current sensors (L411 and L412), select whether MAX values are aggregated or not. This configuration can be password protected.

During installation you will be able to select which AEMC® Instruments control panels you want to install. If you intend to use DataView® for report generation, you **MUST** install the DataView Core Control Panel.

If not using DataView to connect to a control panel, you can perform limited configurations direct through the instrument front panel (see § 3.2.1 Configuring Instrument).

NOTE:



1. You must have administrator rights on your PC to install the DataView Data Logger application software.
 2. **DO NOT** connect the instrument to the computer before installing the software and drivers.
-

To install the software:

1. Insert USB Drive into an available USB port.
2. When the DataView folder opens, **double-click** on  (Setup.exe).
3. The DataView Installer (setup) screen appears.
 - a. From language section **select** desired language for UI.
 - b. From Options list **select** DataView Version.

In addition, you can also select **Adobe Reader**. This links to the Adobe web site where you can download the latest version of Reader to later view the DataView PDF documents.

The Option **User Manuals** displays a list of PDF files contained in the USB drive that accompanies DataView.

When ready, **click Install**. If prompted to allow changes to device, **click Yes**.

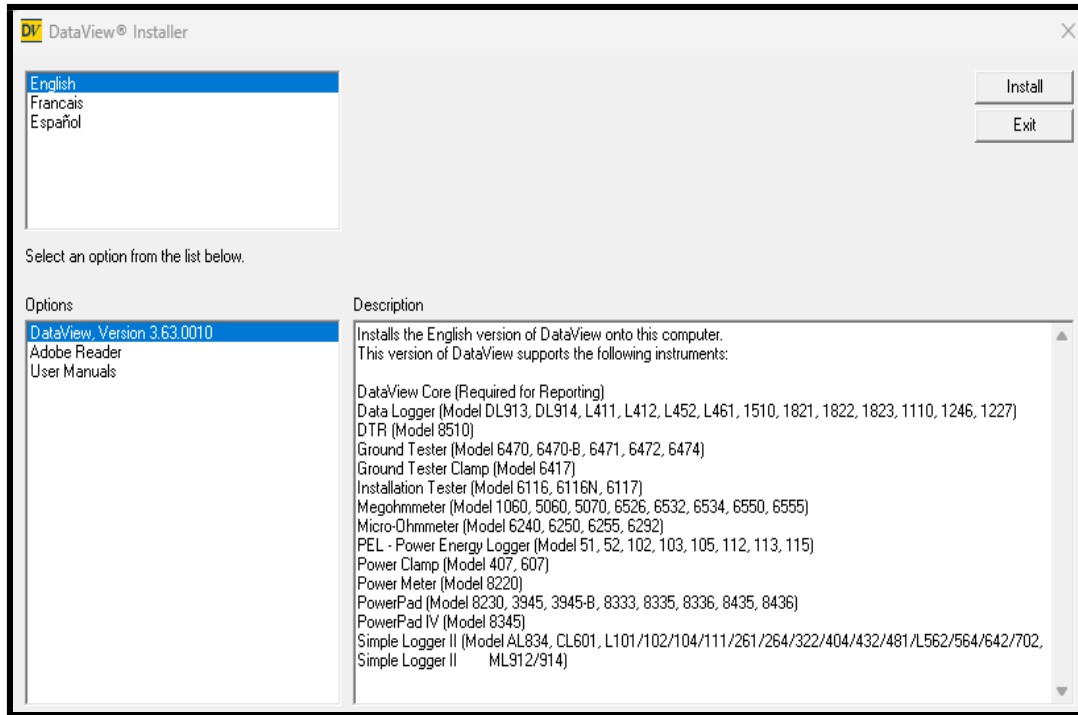

4. Each AEMC® product family has its own control panel. The **Select the software you want to install** screen appears with all options pre-selected indicating a complete install.
NOTE: To later **enable** DataView for report generation, you **MUST now select** DataView Core for install.

To save disk space, **deselect** the software that you **do not** want to install and **click Next**. At any time to review previous selections, **click Previous**.

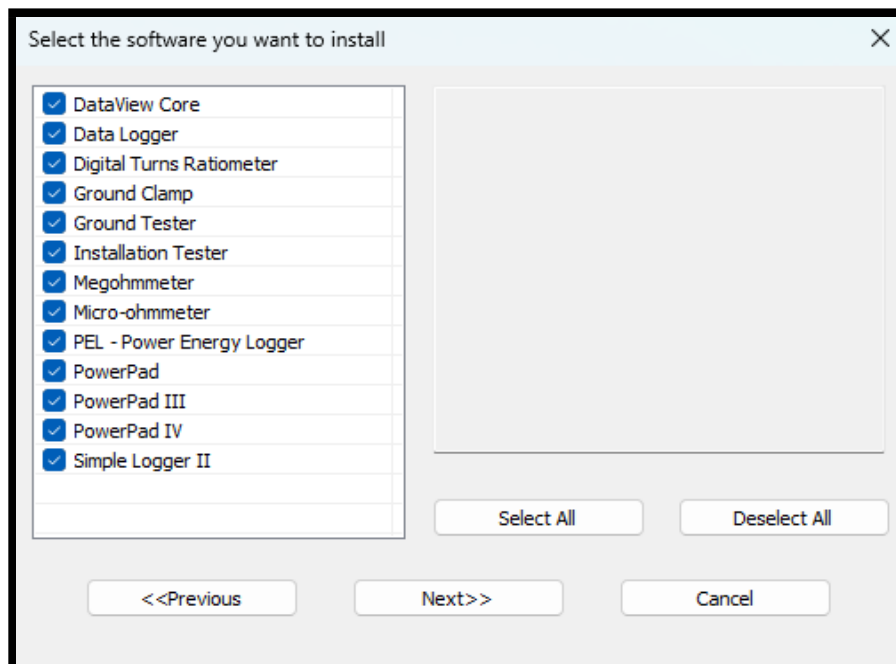

5. The **Install confirm** screen will appear. If the USB Instrument (or cable) is connected to the computer **disconnect** it from computer before proceeding. When ready, **click Install** to proceed. The InstallShield® Wizard begins running.

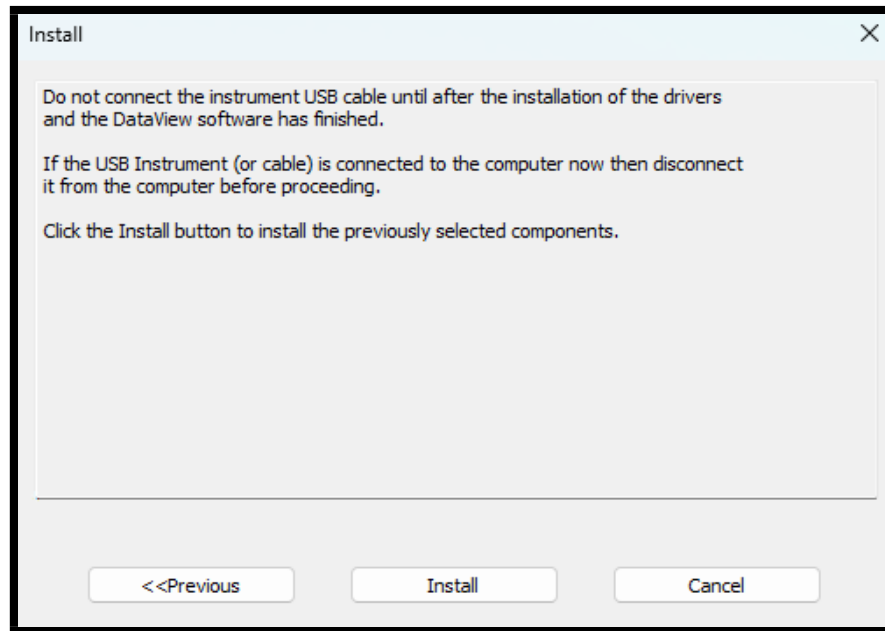

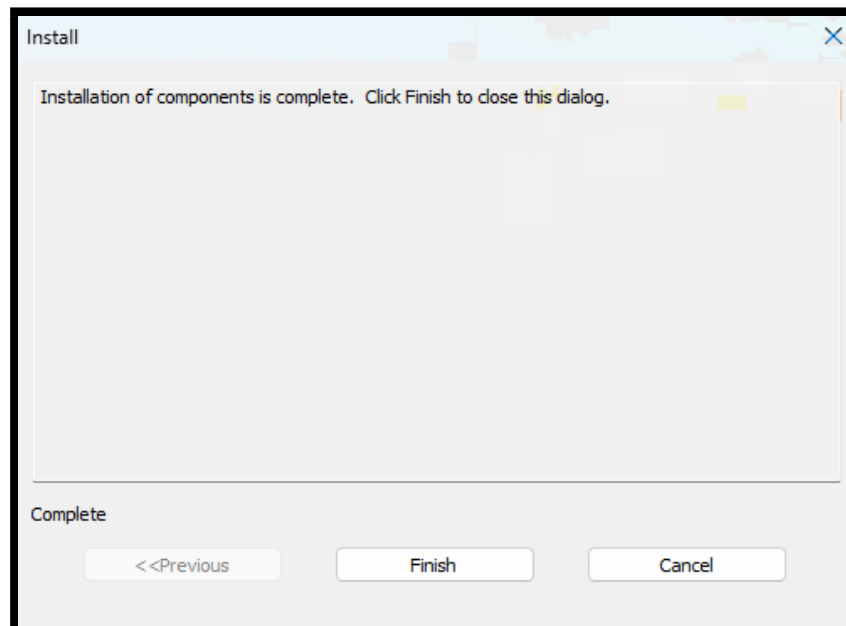

6. The InstallShield® Wizard program installs the selected software. If an earlier version of the software is already installed on your PC, for each selected program the InstallShield® Wizard will:
- (a) Ask you to confirm the installation of the program. **Click Next.**
 - (b) Display a status bar indicating the progress of the installation.
7. When the InstallShield® Wizard has completed, the **Installation of components is complete** screen will appear. **Click Finish.**

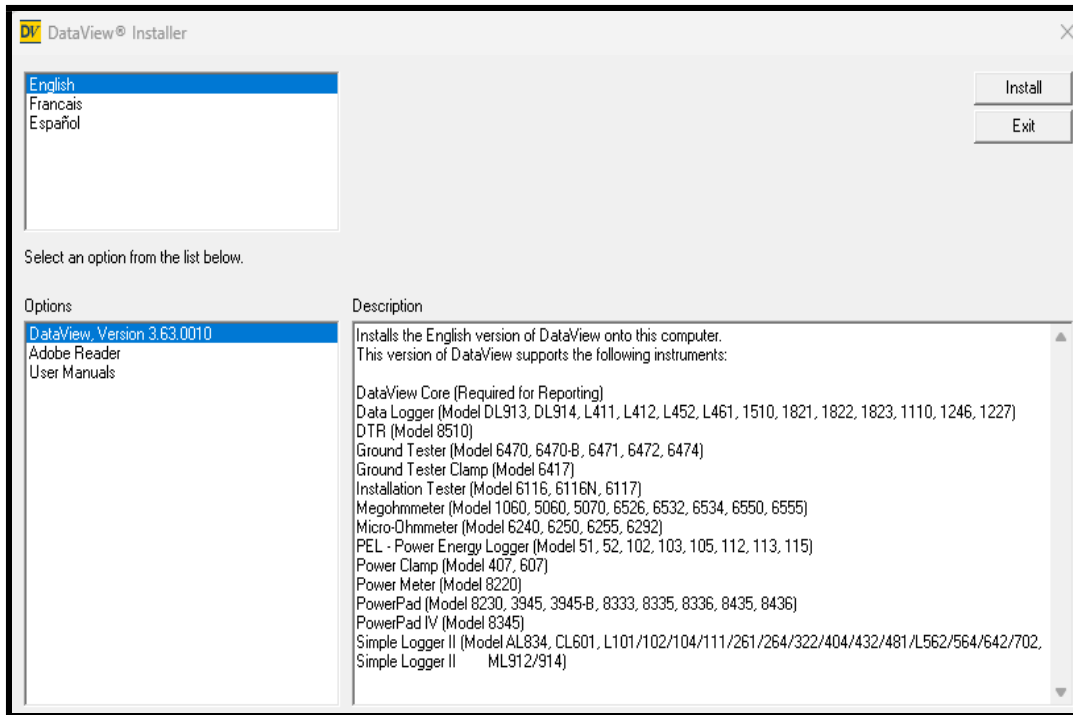

8. The program returns to the **DataView Installer** screen. **Click Exit.**



9. The DataView folder now appears on your PC desktop , within which is the Data Logger Control Panel icon  and icons for any other control panels installed. **Clicking the Data Logger Control Panel icon** opens the Data Logger Control Panel. **Clicking the DataView  icon** in the DataView folder opens the **DataView Core** program.

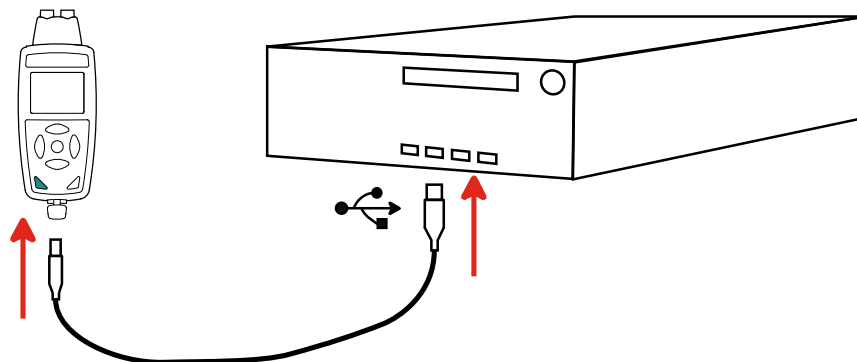

10. You can now open the Data Logger Control Panel and connect your instrument to the computer. Follow the instructions on the instrument or proceed to the next section **Connecting Instrument to Computer.**



CONNECTING THE INSTRUMENT TO COMPUTER

Before you can use the Data Logger Control Panel to communicate with your Data Logger Model L411, L412 or L461, you must establish a connection between the instrument and the computer.

The required communication and connection drivers were installed onto your computer as part of the software installation process completed in the previous section.

1. **Connect** the USB cable to the instrument and computer. The instrument will power on.
2. **Double click** on the DataView Folder  on your desktop to open folder.
3. **Double click** on  to open the Data Logger Control Panel.
4. **Click** on Add an Instrument  .
5. **Select** desired Instrument, **select** desired Model, then **click Next >**.

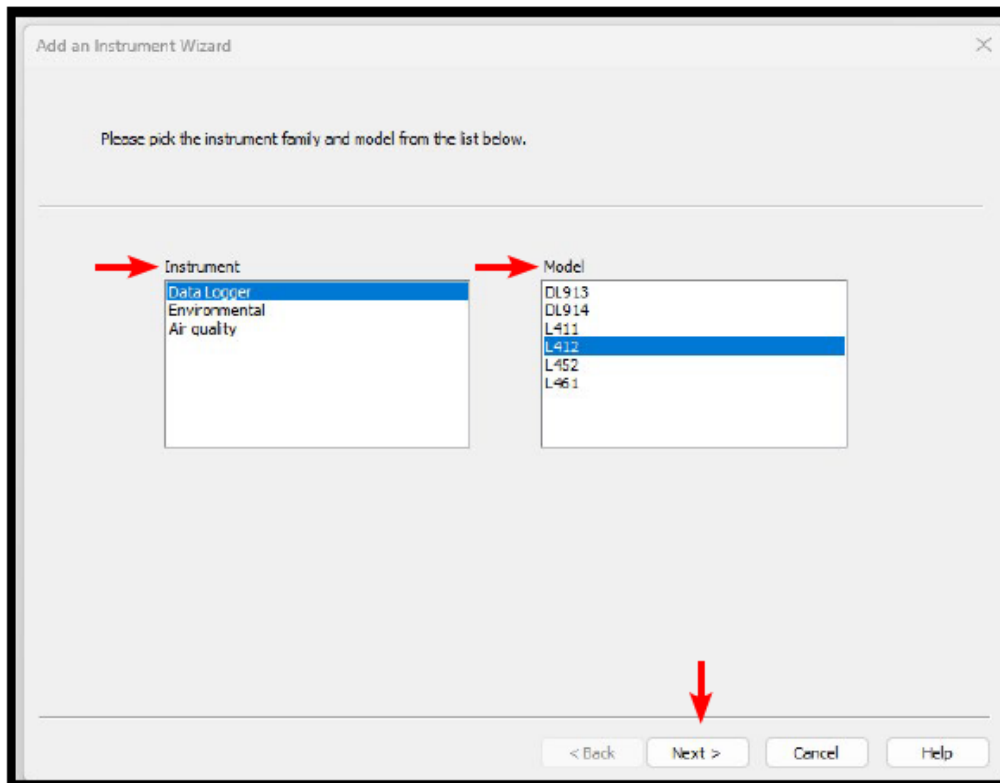

6. Select the desired connection type, then click Next >.

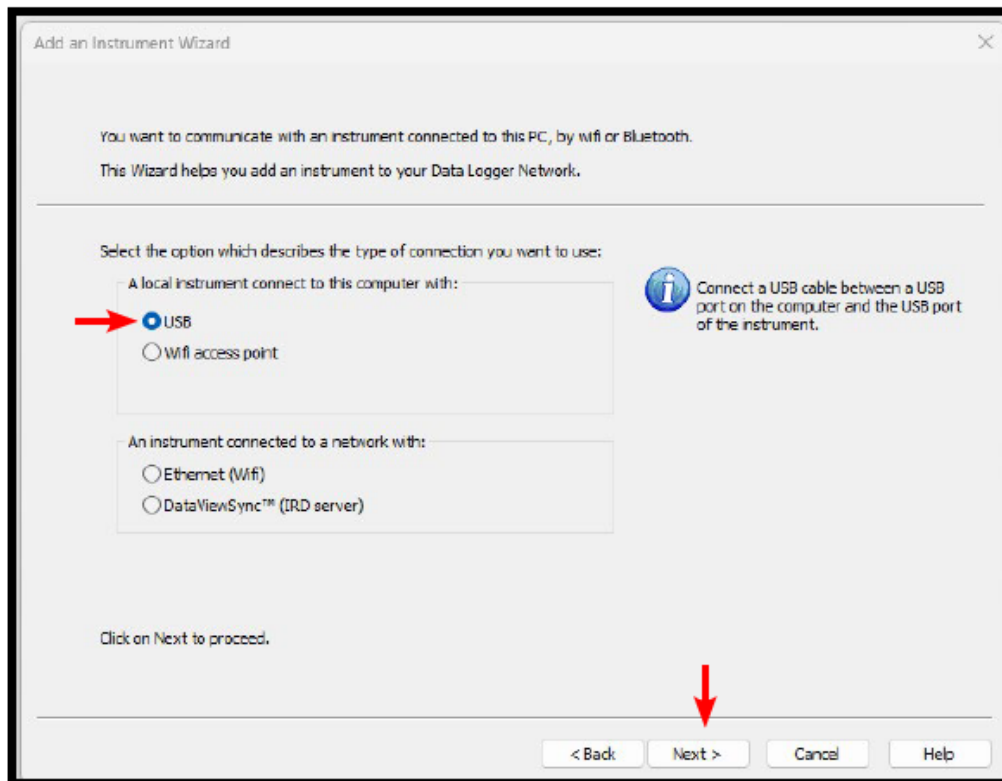

7. Select the desired Instrument from the drop down list, then click Next >. If your instrument does not appear on the list, follow instructions provided on the screen.

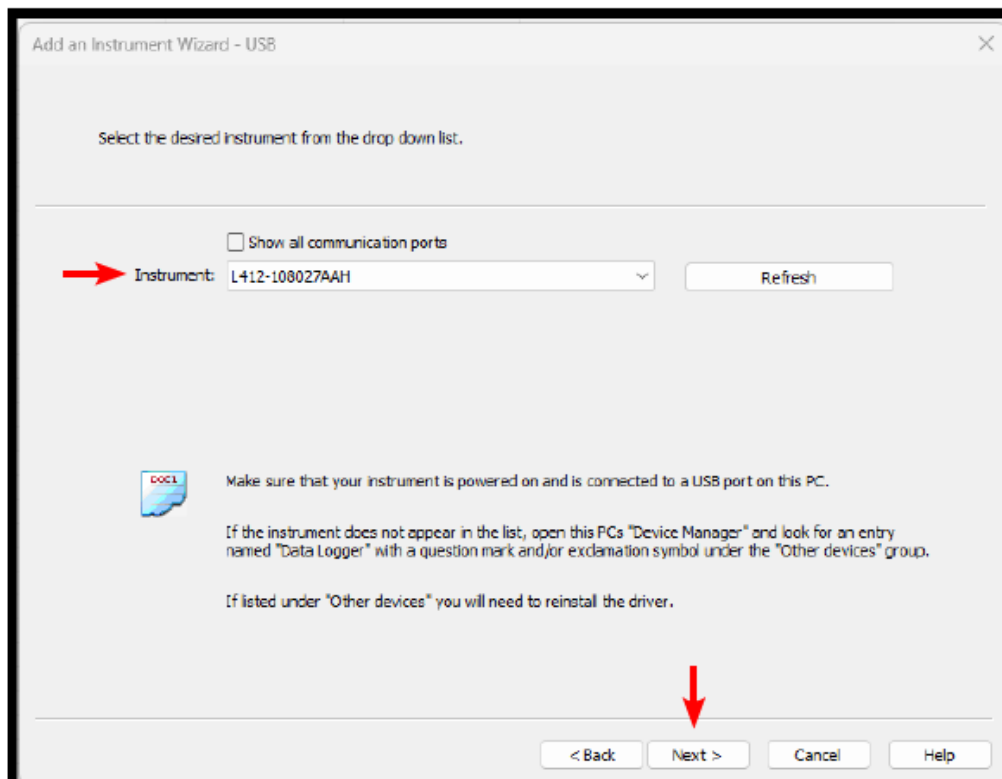

8. If the instrument has been identified, select **Finish** to continue.

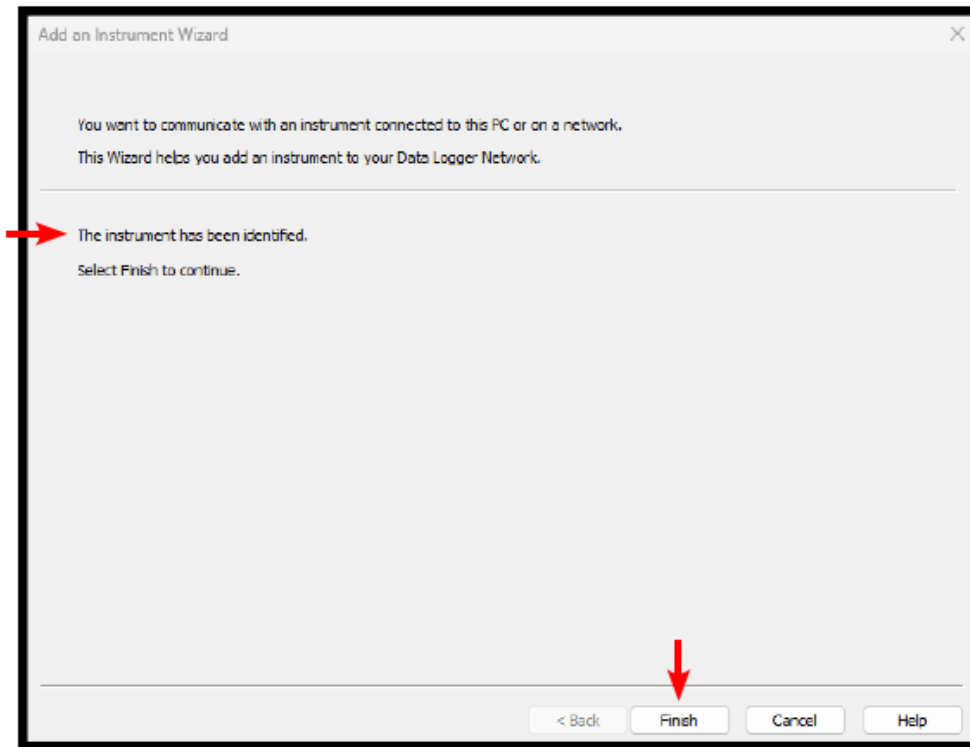

9. The instrument is now connected and the instrument **Status** screen will display.



NOTE: For further information on using the Data Logger Control Panel, access **Help** by pressing **F1** from any screen or by clicking on the Help  icon located on the control panel's top menu bar.

CONFIGURING THE INSTRUMENT VIA CONTROL PANEL

To configure your instrument, select it in the Data Logger Control Panel.

Open the Configure Instrument dialogue box by clicking the **Configure**  icon in the toolbar, in the Instrument menu or in the Status area.

This dialogue box has several tabs:

- **General:** to give a name to the instrument, choose the automatic power-off time, lock the **Select** button on the instrument, set the date and time and format the SD card.
- **Communication:** options relating to communication between the instrument, the PC and the network.
- **Recordings:** choose their name, duration, start and end date, aggregation period and the type of recording.
- **Instrument:** choose AC/DC (L461), choose the frequency, configure the current sensors (L411 and L412), choose the MAX values that are aggregated or not. This configuration can be password protected.

Click **OK** to load the new configuration into the instrument.

CONFIGURING THE INSTRUMENT VIA FRONT PANEL

Limited functions, shown below by model, can be configured directly through the instrument front panel:



- **L411/L412/L461:**
 - set Wi-Fi (OFF, On St, or On AP)
 - set aggregation period (1, 2, 3, 4, 5, 6, 10, 12, 15, 20, 30, or 60)
 - set recording mode (NORMAL or EXTENDED)
 - reset to default
- **L411/L412:** set rated primary current (300 A 1t or 3000 A 1t)
- **L461:** select signal AC or DC

STARTING AND STOPPING A RECORDING





WARNING: The date and time cannot be set through the instrument front panel. Connect the instrument to the DataView® control panel to set the date and time before first use.

To **START** a recording, do one of the following:

- **In Data Logger Control Panel:** Go to the Recording tab of the Configuration dialogue box. The instrument can be configured to trigger a recording either at a future date and time, or immediately after completing the instrument configuration.
- **On the instrument:** Press the Select  button. On the bottom status bar, the instrument will scroll, **START REC. PUSH ENTER TO START RECORDING**. Confirm with the  button. The **REC** symbol blinks.

To **STOP** a recording, do one of the following:

- **In the Data Logger Control Panel:** In the menu, select Instrument > Stop recording .
- **On the instrument:** Press the Select  button. On the bottom status bar, the instrument will scroll, **STOP REC. PUSH ENTER TO STOP RECORDING**. Confirm with the  button. The **REC** symbol disappears.

VIEWING THE RECORDING

To transfer recorded data to the PC for viewing and generating reports:

- **Select** Recorded Sessions in the Data Logger Control Panel navigation tree.
- **Double click** the desired recording session.
- Download will begin. Once the download has finished, **select** it and **click Open** in the Download dialogue box.

The session is added to **My Open Sessions** in the navigation tree. The data can then be displayed.

REPAIR AND CALIBRATION

To ensure that your instrument meets factory specifications, we recommend that it be sent back to our factory Service Center at one-year intervals for recalibration or as required by other standards or internal procedures.

For instrument repair and calibration:

You must contact our Service Center for a Customer Service Authorization Number (CSA#). Send an email requesting a CSA#, you will be provided a CSA Form and other required paperwork along with the next steps to complete the request. Then return the instrument along with the signed CSA Form. This will ensure that when your instrument arrives, it will be tracked and processed promptly. Please write the CSA# on the outside of the shipping container. If the instrument is returned for calibration, we need to know if you want a standard calibration or a calibration traceable to N.I.S.T. (includes calibration certificate plus recorded calibration data).

Ship To: Chauvin Arnoux®, Inc. d.b.a. AEMC® Instruments

(Or contact your authorized distributor.)

Contact us for the costs for repair, standard calibration, and calibration traceable to N.I.S.T.



NOTE: You must obtain a CSA# before returning any instrument.

TECHNICAL SUPPORT

If you are experiencing any technical problems or require any assistance with the proper operation or application of your instrument, please call or e-mail our technical support team:

Chauvin Arnoux®, Inc. d.b.a. AEMC® Instruments

LIMITED WARRANTY

The instrument is warranted to the owner for a period of two years from the date of original purchase against defects in manufacture. This limited warranty is given by AEMC® Instruments, not by the distributor from whom it was purchased. This warranty is void if the unit has been tampered with, abused, or if the defect is related to service not performed by AEMC® Instruments.

Full warranty coverage and product registration is available on our website.

Please print the online Warranty Coverage Information for your records.

What AEMC® Instruments will do:

If a malfunction occurs within the warranty period, you may return the instrument to us for repair, provided we have your warranty registration information on file or a proof of purchase. AEMC® Instruments will repair or replace the faulty material at our discretion.

WARRANTY REPAIRS

What you must do to return an Instrument for Warranty Repair:

First, send an email requesting a Customer Service Authorization Number (CSA#) from our Service Department. You will be provided a CSA Form and other required paperwork along with the next steps to complete the request. Then return the instrument along with the signed CSA Form. Please write the CSA# on the outside of the shipping container. Return the instrument, postage or shipment prepaid to:

Chauvin Arnoux®, Inc. d.b.a. AEMC® Instruments

Caution: To protect yourself against in-transit loss, we recommend that you insure your returned material.



NOTE: You must obtain a CSA# before returning any instrument.

QUICK START GUIDE TRANSLATIONS

Visit our website to view and download a PDF version of this Quick Start Guide

NOTES:



05/26
99-MAN 100647 v00

AEMC[®] Instruments