

Cable Verification & Tracing Analyzer Model 6683



Transmitter (6683E)



Receiver (6683R)

CABLE ANALYZER

ENGLISH

Statement of Compliance

Chauvin Arnoux[®], Inc. d.b.a. AEMC[®] Instruments certifies that this instrument has been calibrated using standards and instruments traceable to international standards.

We guarantee that at the time of shipping your instrument has met the instrument's published specifications.

An NIST traceable certificate may be requested at the time of purchase, or obtained by returning the instrument to our repair and calibration facility, for a nominal charge.

The recommended calibration interval for this instrument is 12 months and begins on the date of receipt by the customer. For recalibration, please use our calibration services. Refer to our repair and calibration section

Serial #: _____

Catalog #: 2127.89

Model #: 6683

Please fill in the appropriate date as indicated:

Date Received: _____

Date Calibration Due: _____



TABLE OF CONTENTS

1. INTRODUCTION.....	7
1.1 INTERNATIONAL ELECTRICAL SYMBOLS.....	7
1.2 DEFINITION OF MEASUREMENT CATEGORIES (CAT).....	7
1.3 PRECAUTIONS OF USE 	8
1.4 RECEIVING YOUR SHIPMENT	8
1.5 ORDERING INFORMATION.....	9
1.5.1 Accessories.....	9
1.6 INSTALLING THE BATTERIES	9
2. FEATURES	10
2.1 MODEL 6683	10
2.2 DISPLAYS	11
2.2.1 Transmitter Display (6683E)	11
2.2.2 Receiver Display (6683R)	11
2.3 BUTTONS	12
2.3.1 Transmitter Keypad (6683E).....	12
2.3.2 Receiver Keypad (6683R)	12
2.4 AUTO OFF.....	12
3. OPERATION	13
3.1 WARNING.....	13
3.2 MEASUREMENT PRINCIPLE.....	13
3.3 GETTING STARTED	13
3.3.1 Connection Example.....	13
3.3.2 Use	14
3.3.3 The 2 Transmitter Connection Modes	14
3.4 UNIPOLAR MODE	14
3.4.1 Locating and Tracing Conductors and Identifying Outlets	14
3.4.2 Locating Line Breaks.....	15
3.4.3 Data Cabling.....	16
3.4.4 Locating Line Interruption Breaks Using Two Transmitters	16
3.4.5 Detecting Faults in an Underfloor (unshielded) Heating System	17
3.4.6 Detecting the Narrowed Part of a Non-metallic Sheath.....	18
3.4.7 Detection of a Metal Water Supply or Heating Pipe	19
3.4.8 Identification of a Power Supply on the Same Floor	20
3.4.9 Tracing a Buried Circuit.....	20









3.5 BIPOLAR MODE	21
3.5.1 Closed Circuit Applications	21
3.5.2 Searching for Fuses	22
3.5.3 Data Cabling	23
3.5.4 Checking for a Short Circuit	24
3.5.5 Detection of Relatively Deeply Buried Circuits.....	24
3.5.6 Sorting or Determining Conductors by Pair.....	25
3.6 METHOD FOR INCREASING THE EFFECTIVE DETECTION RADIUS OF LIVE CIRCUITS	26
3.7 IDENTIFYING THE LINE VOLTAGE AND LOOKING FOR BREAKS IN THE CIRCUIT	27
3.8 TRANSMITTER VOLTMETER FUNCTION	27
4. SPECIFICATIONS	28
4.1 ELECTRICAL SPECIFICATIONS	28
4.1.1 Transmitter.....	28
4.1.2 Receiver	28
4.2 POWER SUPPLY	28
4.3 ENVIRONMENTAL CONDITIONS	28
4.4 MECHANICAL SPECIFICATIONS	28
4.5 COMPLIANCE WITH INTERNATIONAL STANDARDS	29
4.6 ELECTROMAGNETIC COMPATIBILITY (EMC).....	29
5. MAINTENANCE	30
5.1 CLEANING	30
5.2 BATTERY REPLACEMENT	30
5.3 REPAIR AND CALIBRATION	31
5.4 TECHNICAL ASSISTANCE	31
5.5 LIMITED WARRANTY	32
5.5.1 Warranty Repairs	32

1. INTRODUCTION

Thank you for purchasing an AEMC® Instruments **Cable Verification & Tracing Analyzer Model 6683**.

For best results from your instrument and for your safety, read the enclosed operating instructions carefully and comply with the precautions for use. Only qualified and trained operators should use this product.

1.1 INTERNATIONAL ELECTRICAL SYMBOLS

	Signifies that the instrument is protected by double or reinforced insulation.
	CAUTION - Risk of Danger! Indicates a WARNING . Whenever this symbol is present, the operator must refer to the user manual before operation.
	Indicates a risk of electric shock. The voltage at the parts marked with this symbol may be dangerous.
	Battery
	Indicates Important information to acknowledge.
	The product has been declared recyclable.
	This product complies with the Low Voltage & Electromagnetic Compatibility European directives.
	In the European Union, this product is subject to a separate collection system for recycling electrical and electronic components in accordance with directive WEEE 2012/19/EU.

1.2 DEFINITION OF MEASUREMENT CATEGORIES (CAT)

CAT IV: Corresponds to measurements performed at primary electrical supply (< 1000 V).

Example: primary overcurrent protection devices, ripple control units, and meters.

CAT III: Corresponds to measurements performed in the building installation at the distribution level.

Example: hardwired equipment in fixed installation and circuit breakers.

CAT II: Corresponds to measurements performed on circuits directly connected to the electrical distribution system.

Example: measurements on household appliances and portable tools.

1.3 PRECAUTIONS OF USE

This instrument complies with safety standard IEC/EN 61010-2-030 for voltages up to 300 V in CAT III and the leads comply with IEC/EN 61010-031.

Failure to observe the precautions for use may create a risk of electric shock, fire, explosion, and/or destruction of the instrument and of the installations.

- The operator and/or the responsible authority must carefully read and clearly understand the various precautions to be taken in use. Sound knowledge and a keen awareness of electrical hazards are essential when using this instrument.
- If you use this instrument other than as specified, the protection it provides may be compromised, thereby endangering you.
- Do not use the instrument on networks whose voltage or category exceeds those listed.
- Do not use the instrument if it seems to be damaged, incomplete, or poorly closed.
- Before each use, check the condition of the insulation on the leads, housing, and accessories. Any item whose insulation is deteriorated (even partially) must be set aside for repair or scrapping.
- Use only the leads and accessories supplied. The use of leads (or accessories) of a lower voltage or category limits the voltage or category of the combined instrument and leads (or accessories) to that of the leads (or accessories).
- When handling leads and crocodile clips, do not place fingers beyond the physical guard.
- Always use personal protection equipment systematically.
- All troubleshooting and metrological checks must be performed by competent and accredited personnel.

1.4 RECEIVING YOUR SHIPMENT

Upon receiving your shipment, make sure that the contents are consistent with the packing list. Notify your distributor of any missing items. If the equipment appears to be damaged, file a claim immediately with the carrier and notify your distributor at once, giving a detailed description of any damage. Save the damaged packing container to substantiate your claim.

1.5 ORDERING INFORMATION

Cable Verification & Tracing Analyzer Model 6683..... Cat. #2127.89

Includes transmitter & receiver, soft carrying case, set of 2, 5 ft silicone color-coded (red/black) safety leads w/4mm straight/right angle banana plugs, (2) alligator clips (red/black), 110 V outlet adapter with banana plugs, mini ground rod, E14 bulb adapter, (6) 1.5 V AAA (LR03) batteries and multilingual user manual.

1.5.1 Accessories

Probe - Black test probe (Rated 1000 V, CAT IV, 15 A, UL V2).....**Cat. #5000.97**

Probe - Red test probe (Rated 1000 V, CAT IV, 15 A, UL V2).....**Cat. #5000.98**

1.5.2 Replacement Parts

Adapter - 110 V outlet w/4 mm banana plugs **Cat. #2118.49**

Lead - Set of 2, 5 ft silicone color-coded (red/black) with 4 mm straight/right angle banana plugs (Rated 1000 V, CAT IV, UL).....**Cat. #5000.94**

Clip - Safety alligator - Black (1000 V, CAT IV, 15 A, UL V2).....**Cat. #5000.99**

Clip - Safety alligator - Red (1000 V, CAT IV, 15 A, UL V2).....**Cat. #5100.00**

Mini ground rod for use with Models 6681 & 6683 **Cat. #5100.22**

Adapter - E14 Bulb adapter for use with Model 6683 **Cat. #5100.23**

Case - Replacement soft carrying case for Model 6683 **Cat. #5100.24**

1.6 INSTALLING THE BATTERIES

Two sets of six batteries will need to be installed in the transmitter and receiver.

1. Turn the instrument over.
2. Using a screwdriver, remove the (2) screws on the back of the instrument.
3. Remove the battery compartment cover.
4. Position the ribbon at the bottom of the battery compartment.
5. Place the (6) batteries in their housing on the ribbon, matching the polarity indicated.
6. Close the battery compartment cover, making sure that it is fully and correctly closed.
7. Screw the (2) screws back in place and tighten.

When the batteries need to be removed, pull the ribbon.

2. FEATURES

The AEMC® Instruments Cable Verification & Tracing Analyzer Model 6683 is a portable instrument consisting of a transmitter and a receiver. The transmitter and receiver are powered by batteries. They are each equipped with a large backlit LCD.

The Model 6683 makes it possible to:

- search for and detect ungrounded electrical or metal conductors,
- find a short-circuit or break in an electrical cable or conductor.

The Model 6683 indicates the value of the AC or DC voltage present and enables non-contact detection (NCV: Non Contact Voltage) of the phase conductors.

The receiver is equipped with a light to illuminate dark locations.

2.1 MODEL 6683



Figure 1

2.2 DISPLAYS

2.2.1 Transmitter Display (6683E)

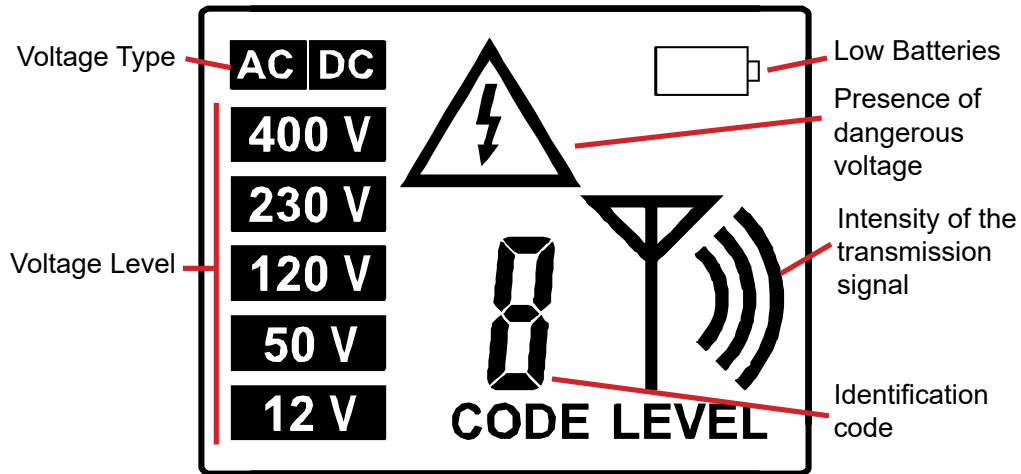

Figure 2

2.2.2 Receiver Display (6683R)

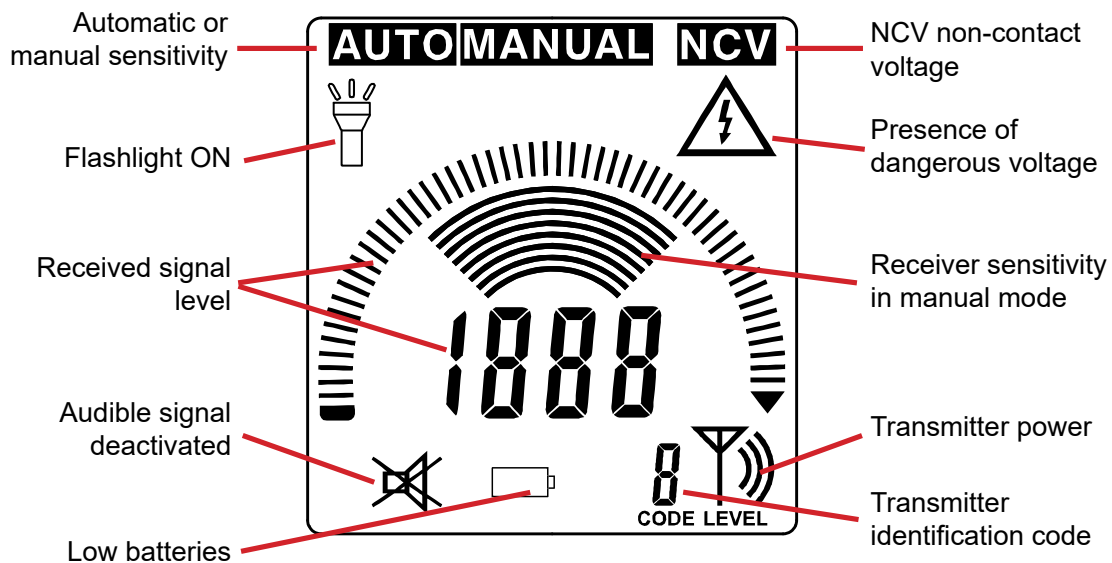













Figure 3

2.3 BUTTONS

2.3.1 Transmitter Keypad (6683E)

	To turn instrument ON and OFF.
	To increase or decrease the signal transmission strength.
	To select the transmitter identification code.
	To switch the display backlighting ON or OFF.

2.3.2 Receiver Keypad (6683R)

	To turn instrument ON and OFF.
	To turn flashlight ON or OFF.
	To increase or decrease signal reception sensitivity in manual mode.
	To activate or deactivate the NCV function.
	Short press: To switch the display backlighting ON or OFF. Long press: To activate or deactivate the sound signal.
	<ul style="list-style-type: none"> ■ To switch detection sensitivity level from automatic to manual mode. In this case, the setting is made using the  and  buttons. ■ If the NCV function is active, it can be deactivated to switch in the transmitter signal detection function.

2.4 AUTO OFF

To save battery life, the receiver switches off automatically after 15 minutes with no buttons being pressed or no voltage detected in **NCV**. Backlighting and the flashlight are not affected by auto power off.

The transmitter does not have an automatic switch-off function, but to save battery life, the backlight switches off after one minute.

3. OPERATION

3.1 WARNING

Connecting the transmitter to a live installation may cause a current in the circuit in the order of a mA. Normally, the transmitter should only be connected between phase and neutral.

If the transmitter is accidentally connected between the phase and the protection conductor, this can, under certain conditions, lead to tripping differential protection devices. In the event of a fault in the installation, all parts connected to ground may become live.

This is why, when using the instrument on a live installation, it is necessary to check beforehand that the installation complies with the standards (NFC15-100, VDE-100, etc., depending on the country), particularly the aspects concerning ground resistance and the connection of the protection conductor to ground.

3.2 MEASUREMENT PRINCIPLE

The transmitter injects an alternating voltage, modulated by digital signals, into the conductor to be identified, generating a proportional alternating electric field.

The receiver is equipped with a sensitive sensor, which displays the level of the electric field detected.

3.3 GETTING STARTED

3.3.1 Connection Example

To understand how the instrument works, make the following example connection.

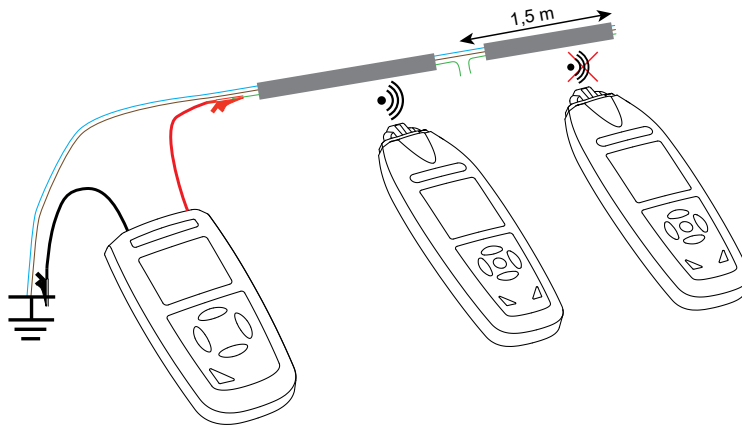











Figure 4

- Take a piece of 3-conductor cable with a section area of 1.5 mm², a few meters long.
- Create an artificial break by cutting one of the conductors about 1.5 m from the end of the cable.
- Using the leads supplied, connect the end of this conductor to one terminal on the transmitter and the other terminal to ground.
- Connect the other conductors of the cable to the same ground.
- At the other end of the cable, the conductors must be in the air (not connected).

3.3.2 Use

- Turn on the transmitter by pressing the  button.
- Press the **CODE SEL**  button to select the transmitter identification code from 1 to 7.
- Press the  and  buttons to set the transmission level to maximum intensity (3 waves).
- Turn on the receiver by pressing the  button. It automatically detects the transmitter's ID code and switches to the same channel.
- By default, the instrument is in automatic (**AUTO**) mode. Press the  button to switch to manual mode (**MANUAL**) in order to adjust the sensitivity. Press the  and  buttons to adjust the signal reception sensitivity. The sound signal changes pitch with the change in signal intensity.
- Move the sensitive part of the receiver slowly along the cable to the location of the break. The display shows the reception level and the received signal level. When the receiver passes over the break, the intensity of the signal displayed drops and eventually disappears completely.
- To refine detection, use the  button to reduce sensitivity as much as possible.

3.3.3 The 2 Transmitter Connection Modes

These two connection modes are the unipolar mode and the bipolar mode.

- In unipolar mode, the connection is made only with the power off.
- In bipolar mode, the connection can be made with the power on or off.

3.4 UNIPOLAR MODE

Unipolar mode is used to:

- detect a break in a conductor in the walls or floors;
- locate and follow a conductor, socket, junction box, switch, etc., in domestic installations;
- locate bottlenecks, kinks, deformations and obstructions in the sheaths and conduits of installations.

In the unipolar mode, connect the + terminal of the transmitter to one conductor and the - to ground. This ground can be an auxiliary ground, the ground terminal of a power outlet or a water pipe connected to ground.

3.4.1 Locating and Tracing Conductors and Identifying Outlets

Preconditions:

- The circuit must be de-energized.
- The neutral conductor and the ground conductor must be connected.

Measurement:

- Connect the transmitter between the phase and the protective conductor.
- Follow the line starting from the socket to find the switch (mechanical or differential) to disconnect this socket.

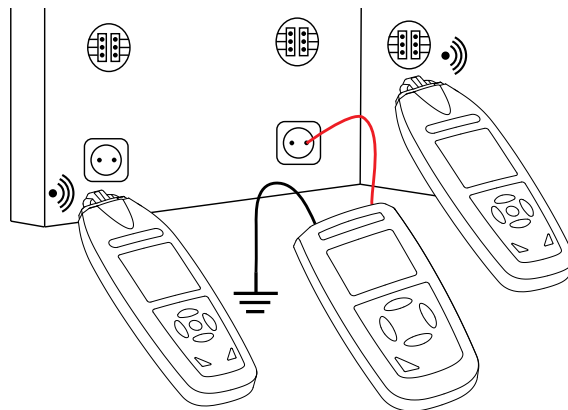

Figure 5



NOTE: If the cable fed by the transmitter signals is close to other conductors, the signal can spread over these cables, creating parasitic circuits and causing erroneous detections.

3.4.2 Locating Line Breaks

Preconditions:

- The circuit must be de-energized.

Measurement:

- Connect the transmitter to the wire being checked and ground.
- Connect all unused lines to ground.
- Move the sensitive part of the receiver slowly along the cable. When the receiver passes over the break, the intensity of the signal displayed drops and eventually disappears completely.
- Fine-tune the detection by minimizing the power level emitted by the transmitter and adjusting the receiver sensitivity to manual mode.

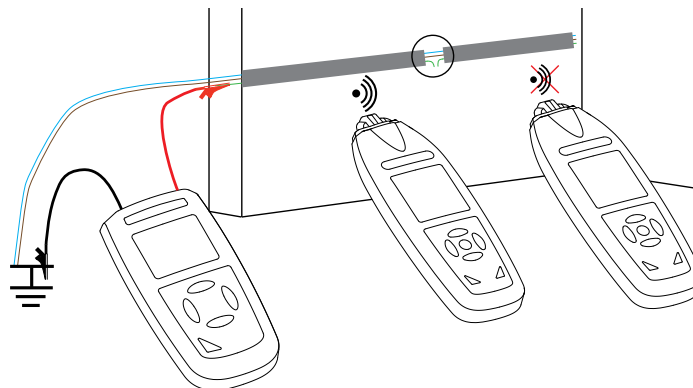

Figure 6



NOTE: The resistance of the interrupted line must be $> 100 \text{ k}\Omega$.

3.4.3 Data Cabling

Unipolar for twisted pair data cable:

Preconditions:

- The cable termination must be removed.
- All pairs must be untwisted and each conductor stripped.
- Join (twist or jumper) all conductors together.

Measurement:

- Connect the transmitter to all conductors of the cable under test and to a nearby grounded point. Ensure that the grounding point has continuity to the equipment grounding network.
- Move the sensitive part of the receiver slowly along the expected cable route or at the termination point to identify the cable under test.
- The transmitter signal may couple into adjacent wiring. Fine-tune detection by reducing the transmitter power level and adjusting the receiver sensitivity in manual mode.

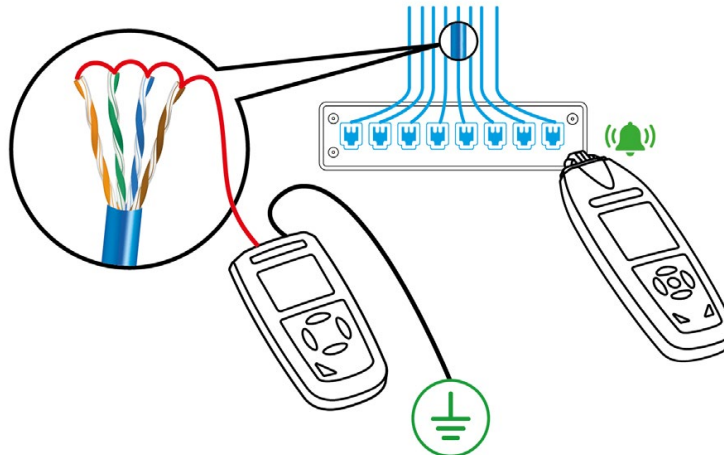

Figure 7



NOTE: It is recommended to use the **unipolar** method for data cabling, as the unipolar method will provide a larger detection area.

3.4.4 Locating Line Interruption Breaks Using Two Transmitters

The location of a line break may not be accurate in the event of unsatisfactory conditions due to field disturbance. By using two transmitters (the second being optional), one at each end of the broken line, a more precise location can be obtained. Each transmitter is set to a different identification code. For example, one on code 7 and the other on code 3.

Preconditions:

- The circuit being measured must not be live.

Measurement:

- Connect the two transmitters to each end of the line.
 - Connect all unused lines to ground.
-

- Move the sensitive part of the receiver slowly along the cable. The receiver will indicate 7 on the left side of the line break and 3 on the right side. When the receiver is placed directly above the break, no line code will be displayed because the signals from the two transmitters are superimposed.
- Fine-tune the detection by reducing the power level emitted by the transmitter and adjusting the receiver sensitivity to manual mode.

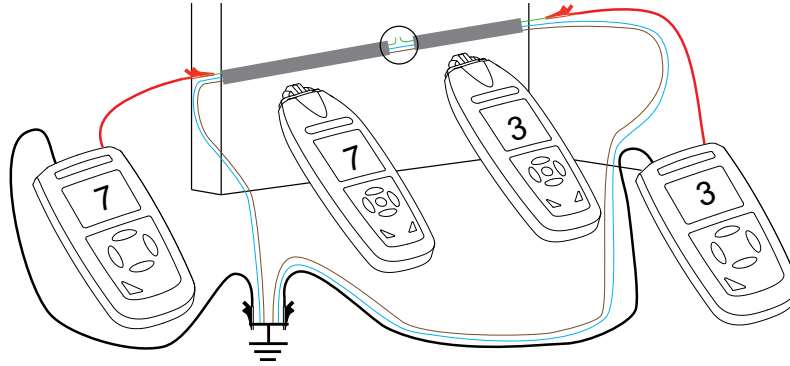

Figure 8



NOTE: The resistance of the interrupted line must be $> 100 \text{ k}\Omega$.

3.4.5 Detecting Faults in an Underfloor (unshielded) Heating System

Preconditions:

- The circuit must be de-energized.
- The resistance circuit must not be shielded with a grounded shield, otherwise the identifier will not work.

Measurement:

- This measurement can be made with one or two transmitters. Connect the transmitter(s) as described in § 3.4.2 or § 3.4.4.
- The measurement method is identical.

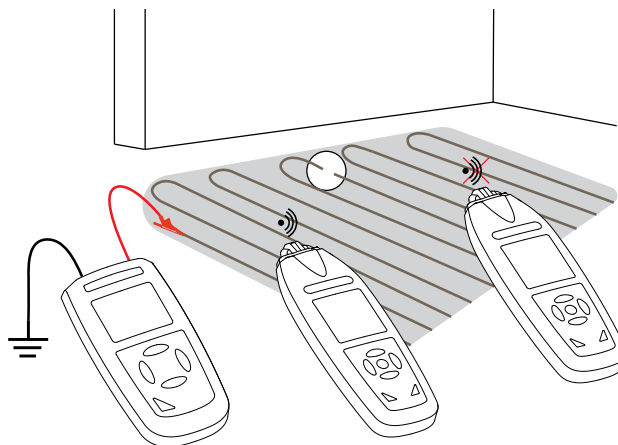

Figure 9

NOTES:

- If there is a shielding layer above the heating wires, there may be no ground connection. If necessary, disconnect the shield from the ground connection.
- Make sure there is a considerable distance between the transmitter ground and the line you are looking for. If this distance is too short, the line may not be located accurately.

3.4.6 Detecting the Narrowed Part of a Non-metallic Sheath**Preconditions:**

- The sheath must be made of a non-conductive material (such as plastic).
- The conductor in the sheath must not be live.

Measurement:

- Connect the transmitter to the metal conductors in the sheath and to an auxiliary ground.
- Move the sensitive part of the receiver slowly along the sheath. When the receiver passes over the narrowed area, the signal intensity displayed drops sharply.
- Fine-tune the detection by minimizing the power level emitted by the transmitter and adjusting the receiver sensitivity to manual mode.

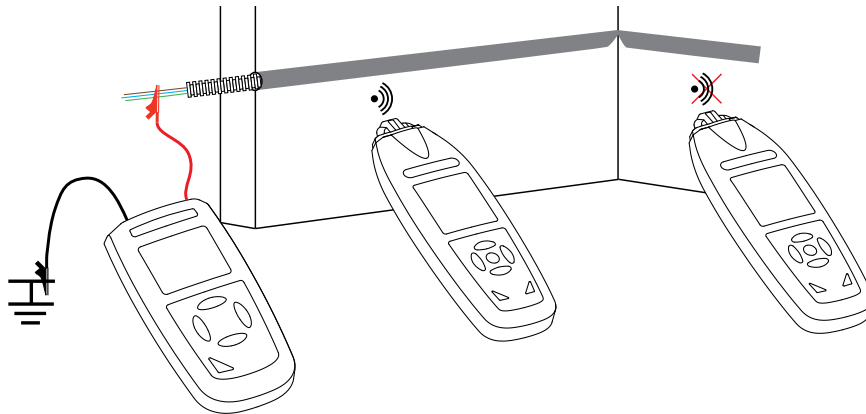

Figure 10

NOTES:

- Make sure there is a considerable distance between the transmitter ground and the sheath being located. If the distance is too short, the sheath may not be located accurately. It is preferable to use a ground connection outside the installation, for example using the grounding rod supplied.
 - If you only have a non-conductive sheath (fiberglass, PVC, etc.), insert a metal wire with a sectional area of around 1.5 mm² into it.
-

3.4.7 Detection of a Metal Water Supply or Heating Pipe

Preconditions:

- The pipe must be conductive (such as galvanized steel).
- The pipe must not be grounded.
- The pipe must not be too close to the ground, otherwise the detection distance will be very short.

Measurement:

- Connect the transmitter to the pipe to be detected and to ground.
- Move the sensitive part of the receiver slowly along the pipe. Follow it along the walls or floor.
- Fine-tune detection by adjusting the power level emitted by the transmitter and the sensitivity of the receiver in manual mode.

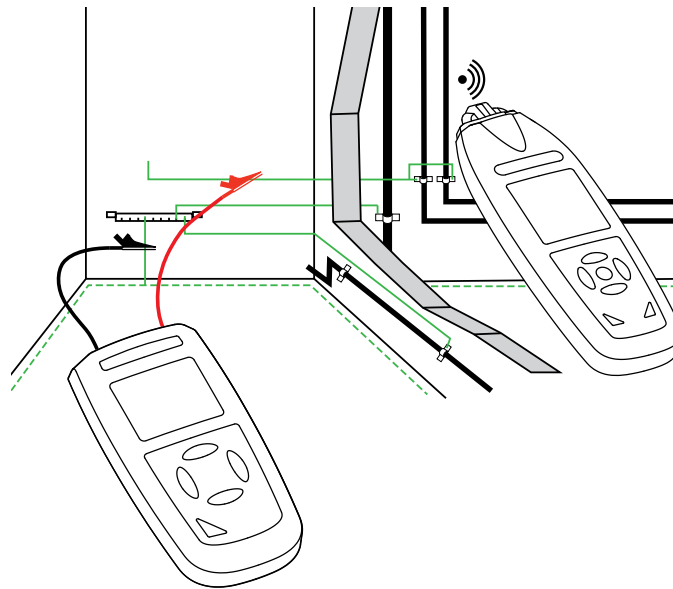

Figure 11

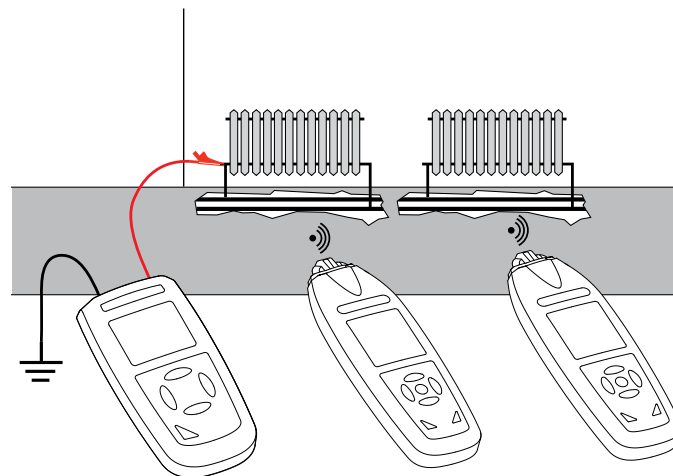

Figure 12

3.4.8 Identification of a Power Supply on the Same Floor

Preconditions:

- The circuit being measured must not be live.

Measurement:

- To cut power, trip the main circuit breaker for this floor.
- In the electrical distribution box, disconnect the neutral wire of the circuit to be identified.
- Connect the transmitter between this neutral wire and an auxiliary ground.
- Fine-tune detection by adjusting the power level emitted by the transmitter and the sensitivity of the receiver in manual mode.

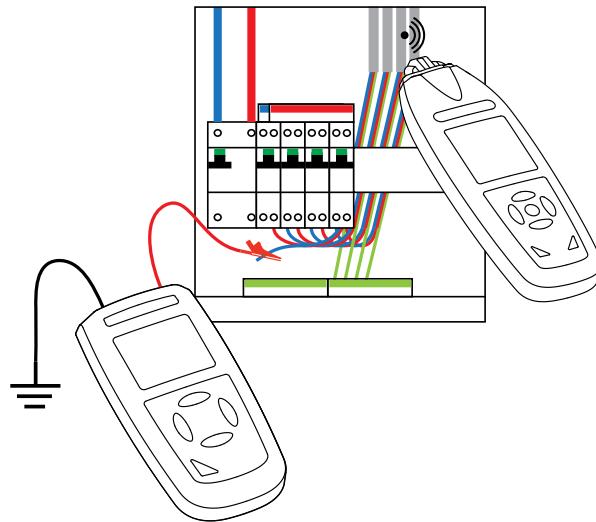

Figure 13

3.4.9 Tracing a Buried Circuit

Preconditions:

- The circuit must not be live.
- The distance between the ground wire and the circuit to be searched for should be as long as possible. If this distance is too short, the circuit may not be located accurately.

Measurement:

- Connect the transmitter between the wire to be searched for and an auxiliary ground.
- Slowly move the receiver along the circuit to be searched for. The strongest signals represent the precise position of the circuit.
- The depth of detection is strongly influenced by the grounding conditions. Select the appropriate receiver sensitivities to locate the circuit accurately.

- The greater the distance between the transmitter and receiver, the lower the power of the signals received, and the shallower the depth of detection.

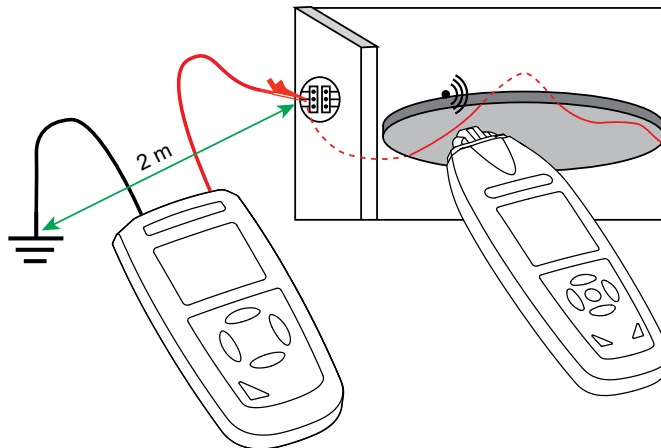

Figure 14

3.5 BIPOLAR MODE

This connection can be used on a live or a de-energized power line. The transmitter is connected to the two conductors by the two test leads.

Connection to a live line:

- Connect the + terminal of the transmitter to the phase.
- Connect the - terminal of the transmitter to neutral.



NOTE: If the terminal - is connected to the ground conductor instead of the neutral, the current from the transmitter is added to the leakage current already present in the installation. The total current can then trip the differential circuit breaker.

Connection to a de-energized line:

- Connect the + terminal of the transmitter to a conductor,
- Connect the - terminal of the transmitter to the other conductor,
- At the end of the line, connect the two wires together.

Alternatively, the two transmitter test leads can be connected to the two ends of a single conductor. In addition, since the installation is de-energized, the ground conductor can also be used without risk.

3.5.1 Closed Circuit Applications

- In de-energized circuits, the transmitter sends signals to the circuits to be detected.
- In live circuits, the transmitter sends signals to the circuits to be detected and also measures the voltage present.

Measurement:

- Connect the transmitter between phase and neutral.
- Follow the line starting from the socket to find the switch (mechanical or differential) to disconnect this socket.

- If necessary, adapt the transmitter's transmitting power.

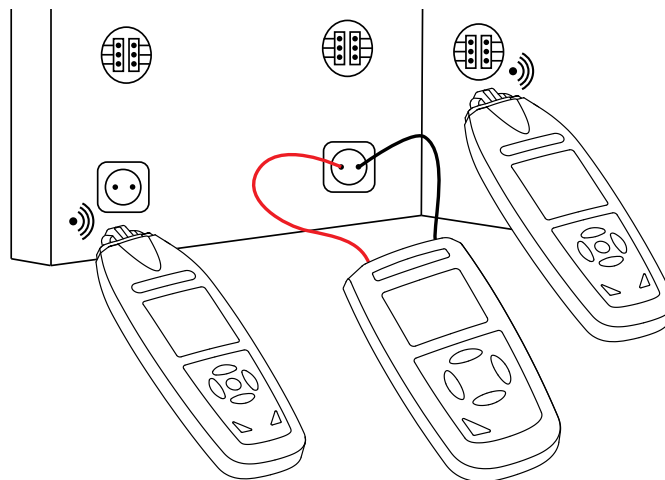

Figure 15

NOTES:



- This method is used to search for outlets, switches, fuses, etc., in electrical installations equipped with sub-distribution cabinets.
- The depth of detection varies depending on the material where the cable is located. It is generally less than 50 cm.

3.5.2 Searching for Fuses

Measurement:

- To cut off the voltage, trip all the distribution box differential breakers.
- Connect the transmitter between the phase and neutral of the circuit for which the protection fuse is being sought. Use the optional connection accessories for power sockets or outlets.
- The fuse sought for is the one with the strongest and most stable signals. The detector can find signals on other fuses, but they are relatively weak.
- For best detection results, place the receiver on the edge of the fuse holder.
- Adjust the transmitter power.
- Select manual mode on the receiver and the appropriate reception sensitivity to locate the circuit accurately.

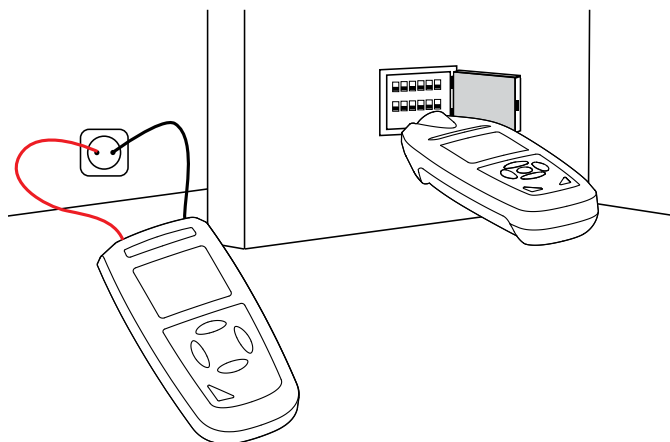

Figure 16



NOTE: The identification and location of fuses is strongly influenced by the state of the wiring in the electrical distribution box. In order to search for fuses as accurately as possible, it may be necessary to open or remove the box cover.

3.5.3 Data Cabling

Bipolar for twisted pair data cable:

Preconditions:

- The cable termination must be removed.
- All pairs must be untwisted and each conductor stripped.
- To increase the effective detection loop, combine multiple conductors to form two larger groups (two **pairs**).

Measurement:

- Connect the transmitter across one selected group (pair) of conductors in the cable.
- Move the sensitive part of the receiver slowly along the expected cable route or at the termination point to identify the cable under test.
- Fine-tune detection by reducing the transmitter power level and adjusting the receiver sensitivity in manual mode.
- For improved identification at the outlet, gently insert the receiver's detection element into the suspected data jack.

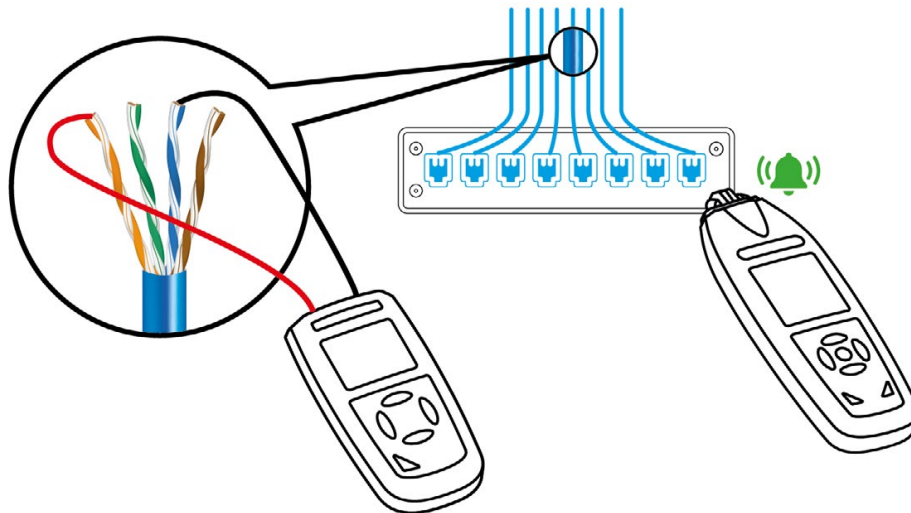

Figure 17



NOTE: It is recommended to use the **unipolar** method for data cabling, as the unipolar method will provide a larger detection area.

3.5.4 Checking for a Short Circuit

Preconditions:

- The circuit must be de-energized.

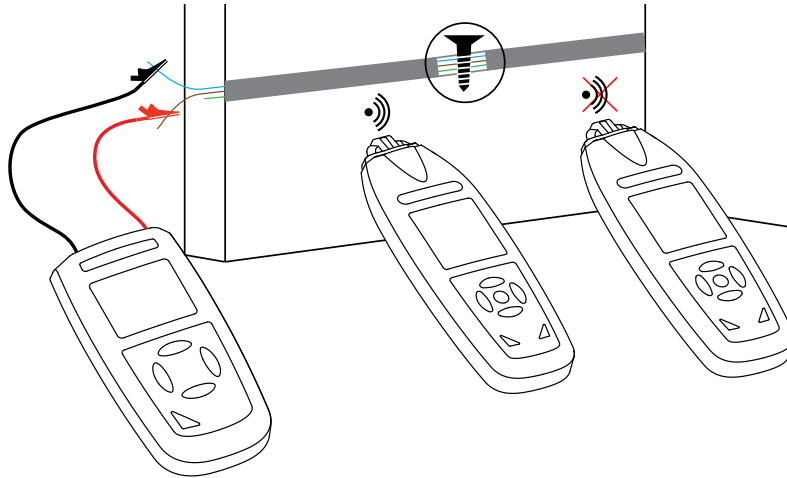

Figure 18

Measurement:

- Connect the transmitter to two of the circuit conductors.
- Move the sensitive part of the receiver slowly along the cable. When the receiver passes over the short-circuit, the intensity of the signal displayed drops and eventually disappears completely.
- Fine-tune the detection by minimizing the power level emitted by the transmitter and adjusting the receiver sensitivity to manual mode.

NOTES:



- When searching for short circuits in sheathed electrical wires and cables, detection depths vary because the wires in the sheath are twisted. Only short circuits with an impedance of $< 20 \Omega$ can be detected correctly. The impedance of the short circuit can be measured with a multimeter.
- If the short-circuit impedance is $> 20 \Omega$, use the method in § 3.4.2. Locating Line Breaks.

3.5.5 Detection of Relatively Deeply Buried Circuits

When measuring in bipolar mode on a multiconductor cable, the depth of detection is severely limited. Use an auxiliary conductor, outside the cable.

Preconditions:

- The circuit must be de-energized.

Measurement:

- Connect the transmitter between one of the circuit conductors and the auxiliary conductor. The distance between the circuit and the auxiliary conductor must be at least 2 m and greater than the burial depth.

- Follow the buried circuit by slowly moving the sensitive part of the receiver.

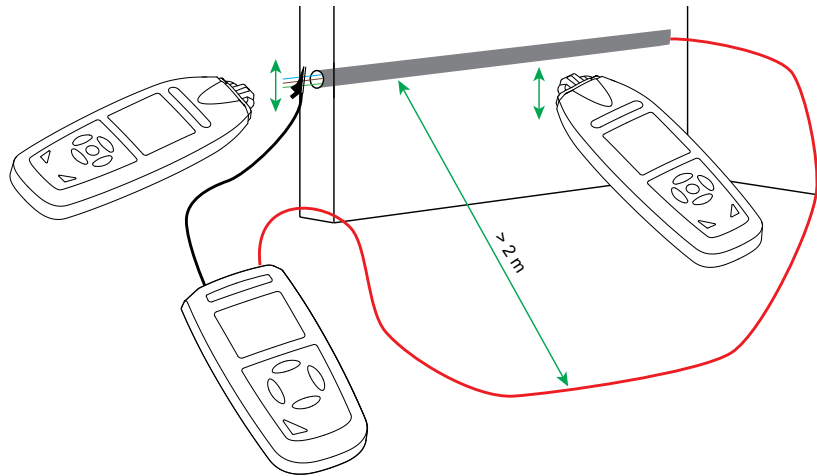

Figure 19



NOTE: In this application, the influence of soil or wall moisture on the depth of detection is negligible.

3.5.6 Sorting or Determining Conductors by Pair

Preconditions:

- The circuit must be de-energized.

Measurement:

- Short-circuit the wire ends of each pair. Each pair remains isolated from the others.
- Connect the transmitter to a pair and assign it an identification code, for **example 7**.
- Connect the transmitter to another pair and assign it a different identification code, for **example 5**.
- Connect the transmitter to a final pair and assign it another identification code, for **example 3**.

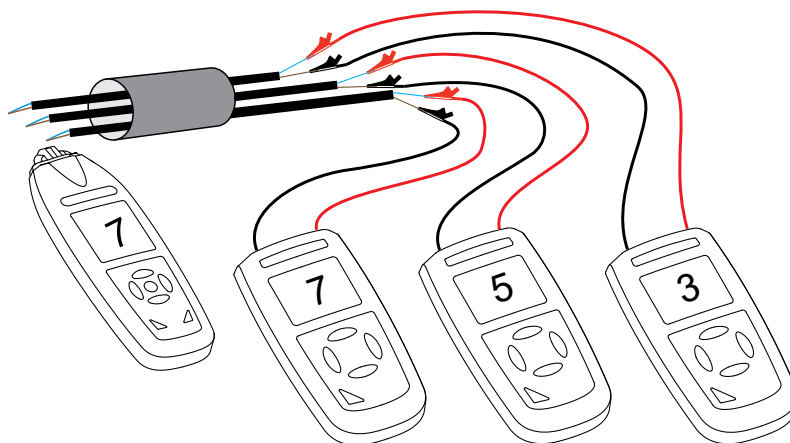

Figure 20



NOTE: You can use several transmitters with different identification codes.

3.6 METHOD FOR INCREASING THE EFFECTIVE DETECTION RADIUS OF LIVE CIRCUITS

The magnetic field produced by the transmitter signal is conditioned by the shape and size (surface area) of the loop created via the **outgoing** conductor (connected to the **+** terminal of the transmitter) and the **return** conductor (connected to the **-** terminal of the transmitter).

In a configuration where the transmitter is connected to the phase and neutral conductors, made up of two parallel wires, the effective detection radius (distance) does not exceed 50 cm.

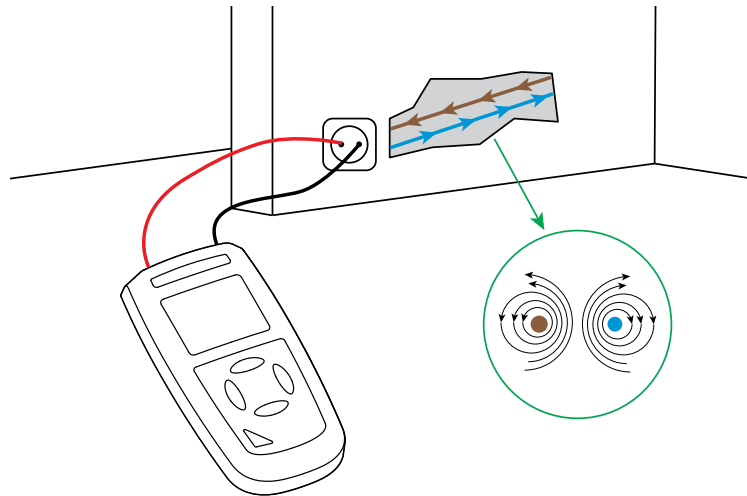

Figure 21

By using a cable extension, a detection distance of up to 2.5 m may be achieved.

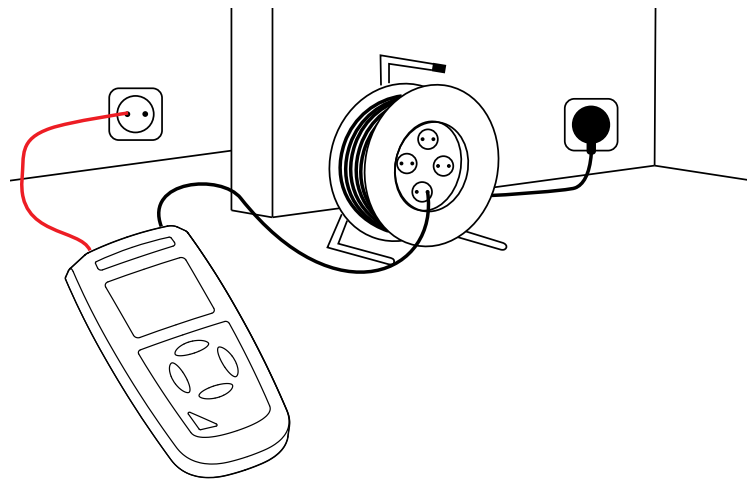

Figure 22

3.7 IDENTIFYING THE LINE VOLTAGE AND LOOKING FOR BREAKS IN THE CIRCUIT

This application does not require the transmitter, unless you wish to use the transmitter's voltmeter function to measure the value of the voltage in the circuit.

Preconditions:

- The circuit must be connected to the power source and energized.

Measurement:

- Press the **NCV** button to activate the non-contact voltage measurement.
- Trace the live line by moving the sensitive part of the receiver.
- The number of bars in the received signal intensity and the audible signal frequency emitted are a function of the voltage in the circuit to be detected and the distance from this circuit. The higher the voltage and the shorter the circuit distance, the more bars are displayed and the higher the frequency of the audible signal.

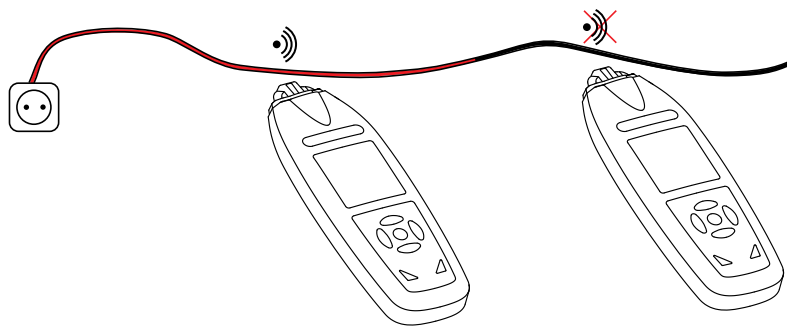

Figure 23



NOTE: When searching for the ends of several supply lines, each line must be connected successively and separately.

3.8 TRANSMITTER VOLTMETER FUNCTION

If the transmitter is connected to a live circuit with a voltage higher than 12 V, the transmitter display will show the value (unsigned in the case of DC) (12 V, 50 V, 120 V, 230 V, 400 V) and the type of voltage (AC or DC).

It will also indicate whether the voltage is dangerous (⚡) or not.

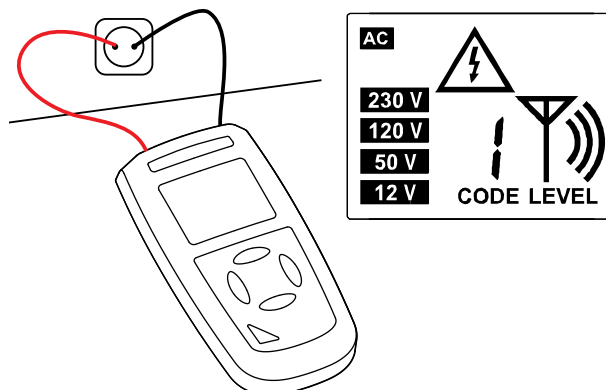

Figure 24

4. SPECIFICATIONS

4.1 ELECTRICAL SPECIFICATIONS

4.1.1 Transmitter

Output signal frequency: 125 kHz

External voltage identification range:

(12 to 400) $V_{DC} \pm 2.5 \%$; (12 to 400) V_{AC} (50 or 60) Hz $\pm 2.5 \%$

4.1.2 Receiver

■ NCV function: (12 to 1000) V_{AC} at 50/60 Hz

■ Detection depth:

- Unipolar application: (0 to 2) m approximately
- Bipolar application: (0 to 0.5) m approximately
- Single loopback line: up to 2.5 m

The detection depth also depends on the material and specific applications.

Line voltage identification: (0 to 0.4) m (0 to 1.31) ft approximately.

4.2 POWER SUPPLY

The transmitter and receiver are each powered by (6) type LR03 or AAA Alkaline batteries.

Transmitter power consumption: between (5 and 36) mA depending on use.

Receiver power consumption: between (16 and 36) mA depending on use.

Battery weight: (12 x 12) g = 144 g approximately

4.3 ENVIRONMENTAL CONDITIONS

For indoor use and outdoor use in dry weather.

Degree of pollution: 2

Altitude < 2000 m

Operating temperature: (32 to 104) °F (0 to 40) °C, with a maximum relative humidity of 80 % (non-condensing).

Storage temperature: (-4 to 140) °F (-20 to +60) °C, with a maximum relative humidity of 80 % (non-condensing).

4.4 MECHANICAL SPECIFICATIONS

Transmitter dimensions (L x W x H): (6.3 x 3.30 x 1.57) in (160 x 84 x 40) mm

Receiver dimensions (L x W x H): (7.8 x 2.63 x 1.42) in (198 x 67 x 36) mm

Transmitter weight: Approximately 12.34 oz 350 g

Receiver weight: Approximately 10.93 oz 310 g

4.5 COMPLIANCE WITH INTERNATIONAL STANDARDS

The transmitter complies with safety standard IEC/EN 61010-2-030 for voltages up to 300 V in CAT III.

The receiver complies with safety standard IEC/EN 61010-031 as a type F sensor for voltages up to 300 V in CAT III.

4.6 ELECTROMAGNETIC COMPATIBILITY (EMC)

The instrument complies with IEC/EN 61326-1.

5. MAINTENANCE



WARNING: Except for the batteries, the instrument contains no parts that can be replaced by untrained or unauthorized personnel. Any unauthorized work or any part replacement with equivalents may seriously compromise safety.

5.1 CLEANING

The instrument should be cleaned periodically to keep the LCD clear and prevent accumulation of dirt and grease around the instrument buttons.

Disconnect everything connected to the instrument.

- Turn instrument OFF.
- Wipe instrument gently with a soft cloth dampened with soapy water.
- Rinse with a damp cloth.
- Dry rapidly with a dry cloth or forced air.
- Do not use alcohol, solvents, or hydrocarbons.
- Do not submerge in water.

5.2 BATTERY REPLACEMENT

When the  symbol appears, all the batteries need to be replaced.

If the  symbol blinks, the batteries are too low to power the instrument and it switches off.

Turn the instrument off and then refer to § 1.4 to replace the battery.



NOTE: Do not treat spent batteries as ordinary household waste. Take them to the appropriate collection facility for recycling.

5.3 REPAIR AND CALIBRATION

To ensure that your instrument meets factory specifications, we recommend that it be sent back to our factory Service Center at one-year intervals for recalibration or as required by other standards or internal procedures.

(Or contact your authorized distributor.)

Contact us for the costs for repair, standard calibration, and calibration traceable to N.I.S.T.



NOTE: You must obtain a CSA# before returning any instrument.

5.4 TECHNICAL ASSISTANCE

If you are experiencing any technical problems or require any assistance with the proper operation or application of your instrument, please call or e-mail our technical support team:

5.5 LIMITED WARRANTY

The instrument is warranted to the owner for a period of two years from the date of original purchase against defects in manufacture. This limited warranty is given by AEMC® Instruments, not by the distributor from whom it was purchased. This warranty is void if the unit has been tampered with, abused, or if the defect is related to service not performed by AEMC® Instruments.

Caution: To protect yourself against in-transit loss, we recommend that you insure your returned material.



NOTE: You must obtain a CSA# before returning any instrument.



12/25
99-MAN 100654 v00

