

■ TRMS LEAKAGE CURRENT
CLAMP-ON METER

565

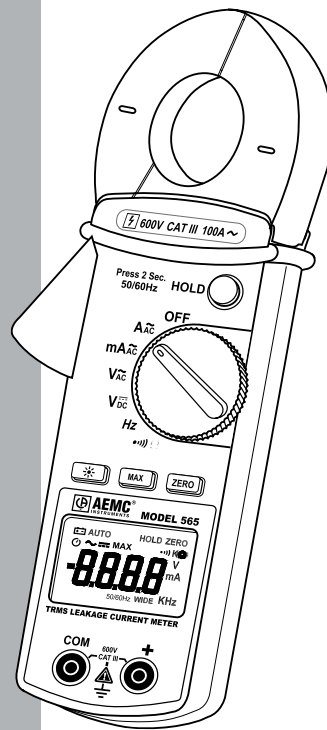

ENGLISH User Manual



Table of Contents

1. INTRODUCTION	3
1.1 International Electrical Symbols	4
1.2 Receiving Your Shipment	4
1.3 Ordering Information	4
2. PRODUCT FEATURES	5
2.1 Description	5
2.2 Model 565 Control Features	6
2.3 LCD Display	7
2.4 Button Functions	8
2.4.1 HOLD Button	8
2.4.2 Backlight Button	8
2.4.3 MAX Button	9
2.4.4 Zero (Relative) Button	9
2.4.5 Auto-OFF	9
3. SPECIFICATIONS	10
3.1 Electrical Specifications	10
3.2 Mechanical Specifications	12
3.3 Environmental Specifications	12
3.4 Safety Specifications	12
4. OPERATION	13
4.1 Precautions Before Use	13
4.2 AC Current Measurement	14
4.2.1 Leakage Current Measurement Examples	15
4.3 AC Volt Measurement	18

4.4 DC Volt Measurement.....	19
4.5 Resistance Measurement	20
4.6 Continuity Measurement	21
4.7 Frequency Measuring Using Current Input	22
4.8 Frequency Measuring Using Voltage Input	23
5. MAINTENANCE	24
5.1 Warning	24
5.2 Cleaning	24
5.3 Battery Replacement.....	25
Repair and Calibration.....	26
Technical and Sales Assistance	26
Limited Warranty	27
Warranty Repairs.....	27

CHAPTER 1

INTRODUCTION

 **Warning** 

- Read the user manual before operating and follow all safety information.
- Only use the meter as specified in this user manual.
- Never use this meter on a circuit with voltages greater than 600Vrms @ 50/60Hz.
- Never measure current while the test leads are connected to the input jacks.
- Do not operate the meter if the case or test leads look damaged.
- Only use factory supplied leads.
- Check the rotary range switch and make sure it is at the correct position before each measurement.
- Do not perform resistance and continuity test on a live circuit.
- Use extreme caution when measuring live systems with voltages greater than 60VDC or 30VAC.
- Use extreme care when working around bus bars and bare conductors.
- Do not use the meter in over range/overload conditions (OL).
- For accurate readings, change the battery when the  symbol appears.

1.1 International Electrical Symbols



This symbol signifies that the instrument is protected by double or reinforced insulation.



This symbol on the instrument indicates a WARNING and that the operator must refer to the user manual for instructions before operating the instrument. In this manual, the symbol preceding instructions indicates that if the instructions are not followed, bodily injury, installation/sample and product damage may result.



Risk of electric shock. The voltage at the parts marked with this symbol may be dangerous.

1.2 Receiving Your Shipment

Upon receiving your shipment, make sure that the contents are consistent with the packing list. Notify your distributor of any missing items. If the equipment appears to be damaged, file a claim immediately with the carrier and notify your distributor at once, giving a detailed description of any damage. Save the damaged packing container to substantiate your claim.

1.3 Ordering Information

Clamp-on Meter Model 565 **Cat. #2117.56**
Includes meter, test leads, two 1.5V AAA (LR03) batteries, user manual and soft carrying case.

1.3.1 Accessories and Replacement Parts

Leads, PTL-30 **Cat. #2118.92**
Replacement Pouch **Cat. #2118.94**

CHAPTER 2

PRODUCT FEATURES

2.1 Description

The TRMS Clamp-on Meter Model 565 is designed to measure low AC currents, which are typically leakage currents in ground conductors. Low currents are measured on the 60mA and 600mA ranges. Note the high sensitivity of the probe: 10 μ A and 100 μ A. This is possible through special jaw construction and in particular critical shielding of the jaws. At low measurement levels, shielding out noise is critical for low sensitivity, accuracy and stability.

Leakage current may be measured on a ground conductor and through the vector sum on multi-conductors. On a grounded system, clamp around the two or three conducting legs (not the ground conductor). The vector sum of the load currents will cancel out, leaving the leakage current measured.

The user may also use the Model 565 as a standard clamp-on meter to 100A_{rms}, plus standard V_{AC}, V_{DC} ranges, resistance and continuity with a buzzer. In mA_{AC} and A_{AC}, the user can activate a low-pass filter to ignore all currents other than 50/60Hz. In this mode, only the fundamental signal is measured. The difference between the full frequency signal (WIDE displayed on LCD) and Filtered mode (50/60Hz displayed on LCD) essentially corresponds to the current attributable to Harmonics.

The Model 565 is ergonomic in design and fits well in the hand. Also, one hand operation is possible. The jaw size is compact yet designed to accommodate most known ground conductors up to 1" (26mm) in diameter.

2.2 Model 565 Control Features

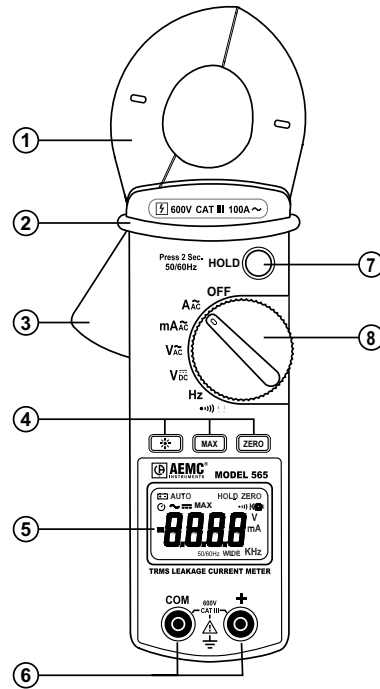

1. Jaw assembly (Ø 1.10", 28mm)
2. Safety barrier anti-slip guard
3. Lever for jaw opening/closing
4. Backlight, Max hold and Zero buttons
5. LCD display
6. COM (Black) and Positive (Red) input terminal jack
7. Data hold button
8. Rotary range selector switch

2.3 LCD Display

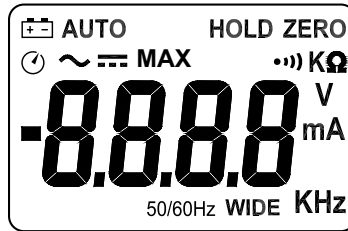

	Low Battery
	Auto-off Indicator
	~ AC / = DC
AUTO	Auto Range
MAX	Max Hold
HOLD	Data Hold
ZERO	Zero Indicator
KΩ	Continuity and Resistance
V	Voltage Indicator
mA A	Current Indicator
KHz	Frequency Indicator
50/60Hz WIDE	Filter Indicator
<i>OL</i>	Overrange

2.4 Button Functions

2.4.1 HOLD Button

This button has two functions.

First Function: HOLD feature

This function locks (holds) the present displayed value.

- To activate, press the **HOLD** button during the measurement. The **HOLD** symbol appears and the measurement is locked.
- To deactivate, press the **HOLD** button again.

Second Function: Frequency Selector feature

When high frequencies from equipment such as inverters are presented in the circuit under test, this instrument measures AC current not just for only 50Hz or 60Hz but harmonic frequency as well.

To eliminate the effect of such high frequency noise and measure only the AC current of 50Hz or 60Hz fundamental frequency, a "high-cut" filter is built in this instrument.

- To activate the Frequency Selector feature, press and hold down the **HOLD** button for approx 2 seconds until the **50/60Hz** symbol displays.
- To deactivate, press and hold down the button again for approx 2 seconds. The meter will return to **WIDE** mode operation.

Note: This feature is active on AAC and mAAC ranges only.

2.4.2 Backlight Button

Press the  button once to turn the backlight on. Press it again to turn it off. When backlight is on, the meter will automatically turn the backlight off after approx 180 seconds (3 minutes).

2.4.3 MAX Button

This function records the maximum value during a measurement.

- To activate, press the **MAX** button during the measurement.
- To deactivate, press the **MAX** button again.

2.4.4 Zero (Relative) Button

This function can be used to compare two voltage measurements (e.g. to determine a voltage drop) or to compensate for the resistance of the leads when making low resistance measurements.

- To activate, press the **ZERO** button to enter the Zero mode. The **ZERO** symbol will appear and Zero the display. The reading is stored as a reference value for subsequent measurements.
- To exit the Zero mode, press the **ZERO** button again.

2.4.5 Auto-OFF

The Model 565 will automatically shut down if there is no activity for approximately 10 minutes .

- To disable the Auto-OFF function, turn the rotary switch to **OFF**.
- Press and hold down the **ZERO** button and set the rotary switch to any position other than **OFF**.
- The  symbol disappears and the Auto-OFF feature is deactivated.

CHAPTER 3

SPECIFICATIONS

Reference Conditions: Accuracy given at 73°F ± 9°F, 80% RH, Conductor Centered in A, Sine wave 48-65Hz, No AC Magnetic Field, External Magnetic Field <40A/m, True RMS (no DC component) for V, A and mA accuracy are specified from 5% to 100% of range. Accuracy add ±1% of Reading on Crest Factor 1.4<CF<3 at full-scale & CF<6 at mid-scale.

3.1 Electrical Specifications

mA Current (TRMS, Auto-ranging)

Range	Res	Accuracy	Max
60mA	10µA	1.2% Rdg ± 5cts (50 to 60Hz) 2.5% Rdg ± 5cts (60 to 500Hz)	150Arms
600mA	100µA	3.5% Rdg ± 10cts (500 to 3kHz)	

Max Voltage to Ground: 600V

AC Current (TRMS, Auto-ranging)

Range	Res	Accuracy	Max
10A	1mA	1.2% Rdg ± 5cts (50 to 60Hz) 2.5% Rdg ± 5cts (60 to 500Hz) 3.5% Rdg ± 10cts (500 to 3kHz)	150Arms
100A*	10mA	1.2% Rdg ± 5cts (50 to 60Hz) 2.5% Rdg ± 5cts (50 to 500Hz) 3.5% Rdg ± 10cts (500 to 3kHz) *80 to 100A: 5.0% Rdg ± 5cts (50-60Hz)	

Max Voltage to Ground: 600V

AC Voltage (TRMS)

Range	Res	Accuracy	Max
600V	0.1V	1.0% Rdg ± 5cts (50 to 60Hz) 1.2% Rdg ± 5cts (50 to 500Hz) 2.5% Rdg ± 5cts (500 to 3kHz)	660Vrms

Max Voltage to Ground: 600V

Input Impedance: 1MΩ, <50pF

DC Voltage

Range	Res	Accuracy	Max
600V	0.1V	1% Rdg ± 3cts	660Vrms

Input Impedance: 1MΩ

Hz - Frequency (Auto-ranging)

Function	Range	Res	Sensitivity	Accuracy
A-Hz	0 to 100Hz	0.1Hz	10mArms min	0.5% Rdg ± 2cts
	100 to 1kHz	1Hz		
V-Hz	0 to 100Hz	0.1Hz	5Vrms min	
	100 to 1kHz	1Hz		

Max Protection: 660Vrms, 150Arms

Resistance - Ohms (Ω)

Range	Res	Accuracy	Test Voltage	Overload
1kΩ	0.1Ω	1% Rdg ± 3cts	3.3V _{DC} max	660Vrms

Continuity (•••))

Range	Res	Buzzer	Test Voltage	Overload
1kΩ	0.1Ω	< 35Ω ± 25Ω	3.3V _{DC} max	660Vrms

Overload: \overline{OL} is displayed and buzzer will sound

Nominal Sample Rate: 2 measurements/sec approx

MAX Sample Rate: 100 ms

Power Supply: Two 1.5V AAA (LR03) alkaline batteries

Clamp-on Meter Model 565

11

Low Battery Indication: The  symbol is displayed when battery is below the required voltage

Battery Life: 45 hrs approx

Auto Power Off: 10 minutes approx with over-ride

3.2 Mechanical Specifications

Digital Display: 4-digit LCD display (9999 max)

Display Backlight: LED with backlight; 180s Auto-OFF

Jaw Opening Size: 1.10" (28mm)

Dimensions: 8.5 x 2.5 x 1.18" (218 x 64 x 30mm)

Weight: 10 oz (280g) with batteries

3.3 Environmental Specifications

Altitude: 2000m (6000ft)

Operating Temperature:
32° to 104°F (0° to 40°C), <80% RH, non-condensing

Storage Temperature:
14° to 140°F (-10° to 60°C), <70% RH, battery removed

3.4 Safety Specifications

EN 61010-1 Ed. 2001, EN 61010-2-032 Ed. 2003

600V, Cat. III

Double Insulation; Pollution Degree 2

Altitude <2000m



CHAPTER 4

OPERATION

4.1 Precautions Before Use

 **IMPORTANT WARNING** 

- **DO NOT touch the voltage input jacks when measuring current.**
- **DO NOT measure current while the test leads are connected to the input jacks.**
- **DO NOT touch the jaw's magnetic core when measuring voltage.**

4.2 AC Current Measurement

 **Remove test leads before measuring current.**

- Turn the range switch to the **A \tilde{c}** or **mA \tilde{c}** range.
- Press the lever to open the jaws.
- Clamp the jaws around the conductor to be measured.
- To freeze the reading, push the **HOLD** button. Push the button again to release.

 **Immediately unclamp the meter from the conductor if "OL" is displayed.**

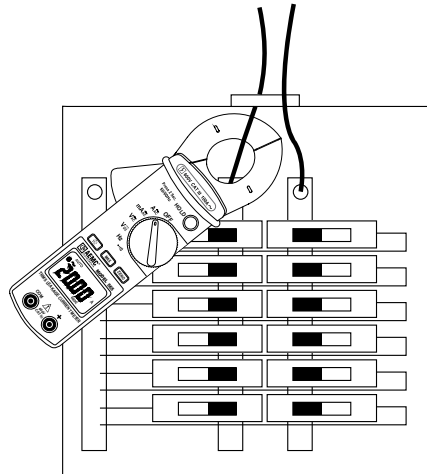

4.2.1 Leakage Current Measurement Examples

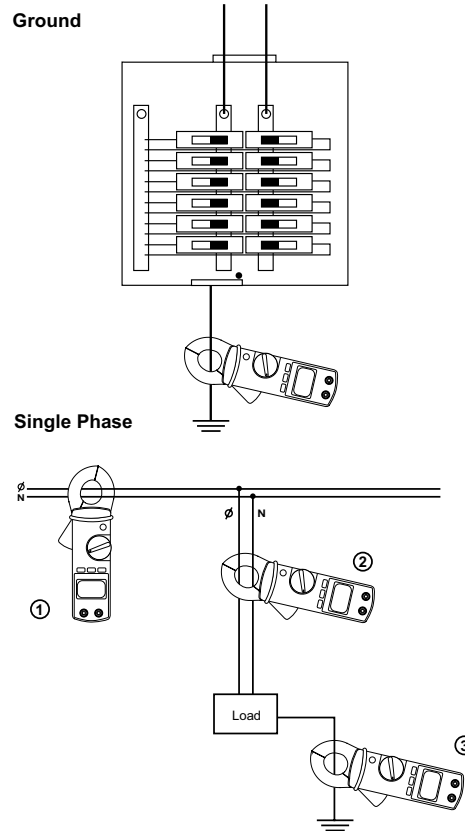

1. Measure branch leakage current (leakage from all loads on branch)
2. Measure leakage current on load
3. Measure leakage current on load to Ground/Earth

Two-Phase

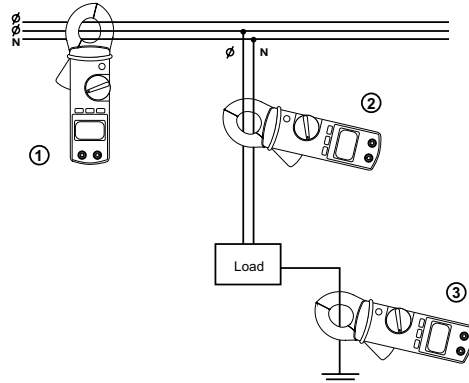

Three-Phase - 3 Wire

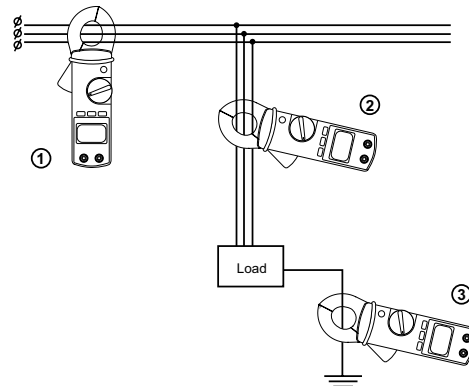

1. Measure branch leakage current (leakage from all loads on branch)
2. Measure leakage current on load
3. Measure leakage current on load to Ground/Earth

Three-Phase - 4 Wire

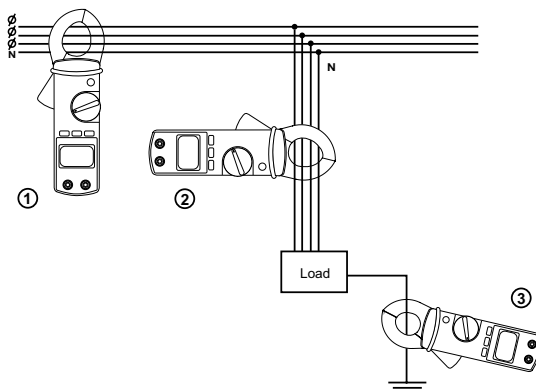

1. Measure branch leakage current (leakage from all loads on branch)
2. Measure leakage current on load
3. Measure leakage current on load to Ground/Earth

NOTE: These drawings are for reference only. Jaw size may not permit all measurements. Contact AEMC® Instruments for other leakage current probes.

4.3 AC Volt Measurement



WARNING: Maximum Input Voltage is 600V_{AC}. Do not exceed this voltage to avoid electrical shock and/or damage to the instrument

- Turn the rotary range switch to the **V_{AC}** range.
- Insert the red test lead to the red "+" input jack and the black lead to the black "**COM**" input jack.
- Bring the test probe tips into contact with the test points.



WARNING: Immediately remove the leads from the conductor if "**OL**" is displayed.

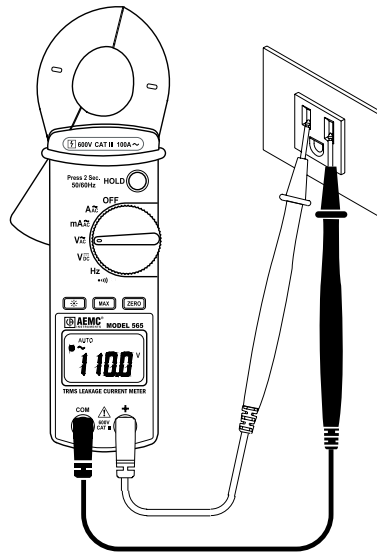

4.4 DC Volt Measurement



WARNING: Maximum Input Voltage is 600V_{DC}. Do not exceed this voltage to avoid electrical shock and/or damage to the instrument

- Turn the rotary range switch to the V_{DC} range.
- Insert the red test lead to the red "+" input jack and the black lead to the black "COM" input jack.
- Bring the test probe tips into contact with the test points.



WARNING: Immediately remove the leads from the conductor if "OL" is displayed.

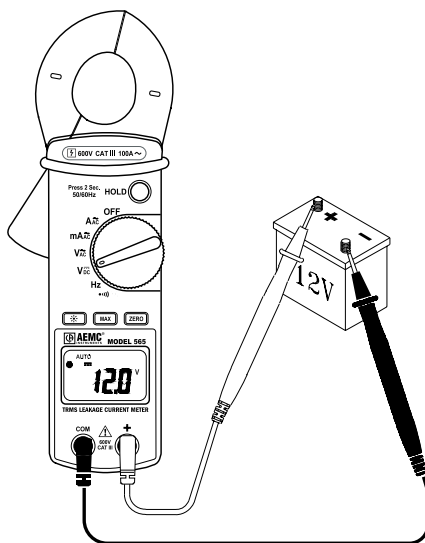

Clamp-on Meter Model 565

4.5 Resistance Measurement

- Turn the rotary range switch to the Ω range.
- Insert the red test lead to the red "+" input jack and the black lead to the black "COM" input jack.
- Bring the test probe tips into contact with the sample under test.



WARNING: When testing Resistance, make sure that there is no power in the tested sample or circuit (dead circuit). Also make sure the current is fully discharged. This may be checked by using the voltage functions.

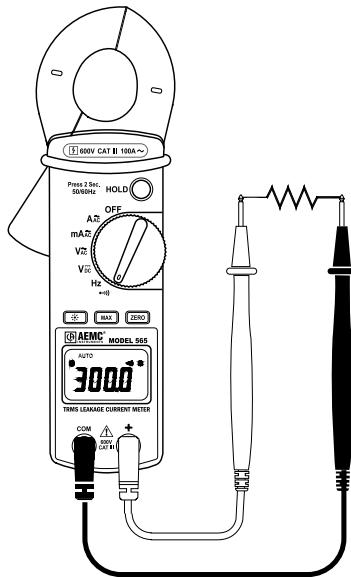

4.6 Continuity Measurement

- Turn the rotary range switch to the Ω range.
- Insert red test lead to the red "+" input jack and the black lead to the black "COM" input jack.
- Bring the test probe tips into contact with the sample under test.
- If the resistance is less than 40Ω , the beeper emits a continuous sound.



WARNING: When testing Continuity, make sure that there is no power in the tested sample or circuit (dead circuit). Also make sure the current is fully discharged. This may be checked by using the voltage functions.

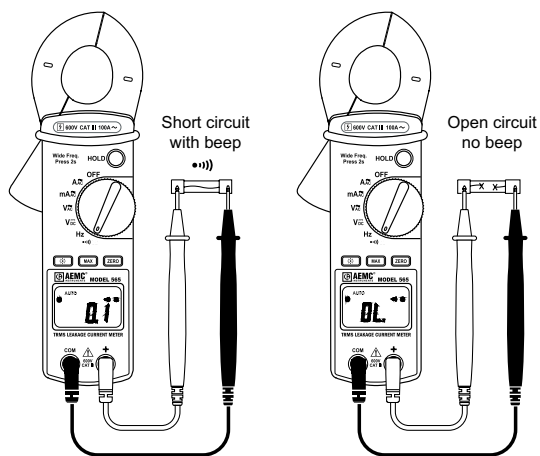

4.7 Frequency Measuring Using Current Input

- Turn the rotary range switch to the **Hz** range.
- Press the lever to open the jaws.
- Clamp the jaws around the conductor to be measured.



WARNING: When performing a Frequency measurement, you should either use the voltage signal or current signal, but never both together. If both sources are applied an error reading will occur.

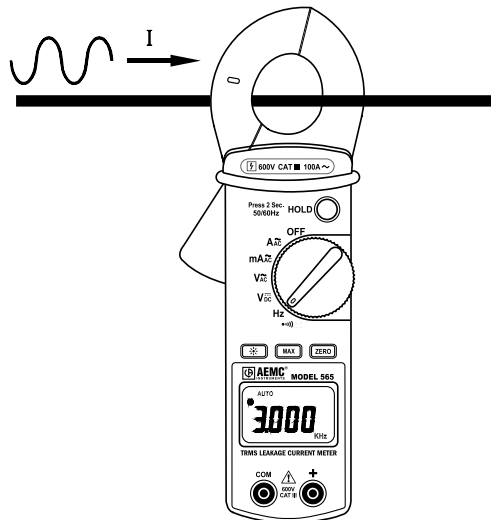

4.8 Frequency Measuring Using Voltage Input

- Turn the rotary range switch to the **Hz** range.
- Insert red test lead to the red "+" input jack and the black lead to the black "**COM**" input jack.
- Bring the test probe tips into contact with the sample under test.

 **WARNING:** When performing a Frequency measurement, you should either use the voltage signal or current signal, but never both together. If both sources are applied an error reading will occur.

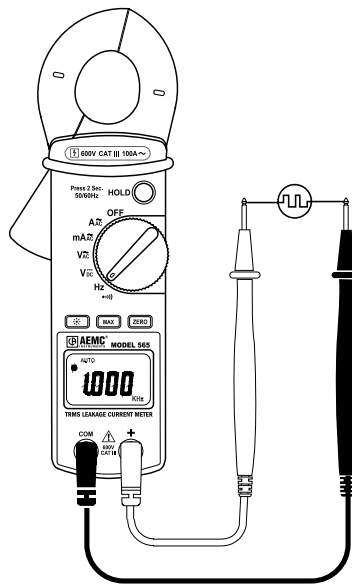

CHAPTER 5

MAINTENANCE

5.1 **Warning!**

- Remove the test leads from any input and sample before opening the case.
- Remove the clamp from any circuit.
- Do not operate the clamp-on probe without a battery case cover.
- To avoid electrical shock, do not attempt to perform any servicing unless you are qualified to do so.
- To avoid electrical shock and/or damage to the instrument, do not get water or other foreign agents into the probe.

5.2 **Cleaning**

- To clean the probe, wipe the case with a damp cloth and mild detergent.
- Do not use abrasives or solvents.
- Do not get water inside the case. This may lead to electrical shock or damage to the instrument.
- Thoroughly dry all parts before using again.

