



Air flow velocity matrix with telescope

Application information



Technical data

Feature	Values
Air flow velocity matrix area	Approx. 360 x 360 mm
Telescope length	1800 mm
Offset factor (S factor)	0.82

Application

The air flow velocity matrix 0635 8888, Testo ID no. 0699.7077/1 and 0699.7077/2, can be used in conjunction with a differential pressure measuring instrument to measure the air flow velocity at large supply air diffusers with laminar flow, e.g. extractor hoods, HEPA filters, safety cabinets in cleanrooms and other applications.

Overview

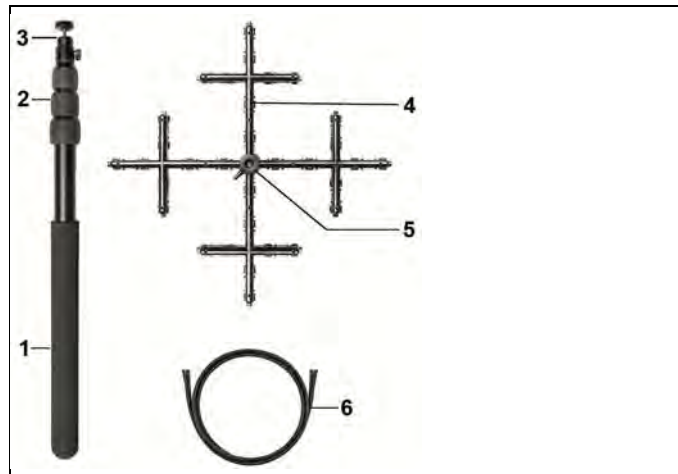

- 1 Handle
- 2 Telescope, length 1.8 m
- 3 Ball joint
- 4 Differential pressure cross with 16 measuring point recordings
- 5 Hose connection
6. Connection hoses silicone-free

Calculating the flow velocity

The flow velocity is calculated by differential pressure measuring instruments with an input facility for the Pitot tube factor (0.82) as follows:

$$V = Sx \sqrt{\frac{2 \times P_{dyn}}{\rho}}$$

S: Pitot tube factor

P_{dyn} : Dynamic pressure (Pa)

ρ : Density (kg/m^3)

Carrying out a measurement

1. Connect the supplied connection hoses to the differential pressure cross.
2. Use the Velcro fastener to fasten the hoses to the telescopic rod.



Do not attach the Velcro fastener to the tripod too tightly. This prevents any kinking and/or stresses in the hose when pulling out or pushing in the telescopic rod.

-
3. Connect the hose ends to a differential pressure measuring instrument. (Testo recommends the testo 420 differential pressure measuring instrument, measuring range 0.2 to 14 m/s)
> Make sure that the hoses are connected correctly.
 4. Hold the air flow velocity matrix at a distance of approx. 5 cm to the air outlet. Ensure that the matrix is exposed to the flow across its entire area.



For the Pitot tube factor setting, please refer to the instruction manual of the measuring instrument used.

>Start measurement.